

HF9L*\$\$A5-B; 95F75G9I D; F589
5H*\$\$!A; 7 f5 @*\$%H*L

±PA 'BC "	8 9G7 F-ĐHC B	E HM
%	H*\$\$A 9!5@A 5-B; 95F75G9I D; F589	%
&	8F5K B7I DFC @F 7 @ H7 < f k: %&%L fDFCJ -898 -B 'C F ≠ B5@?L	%

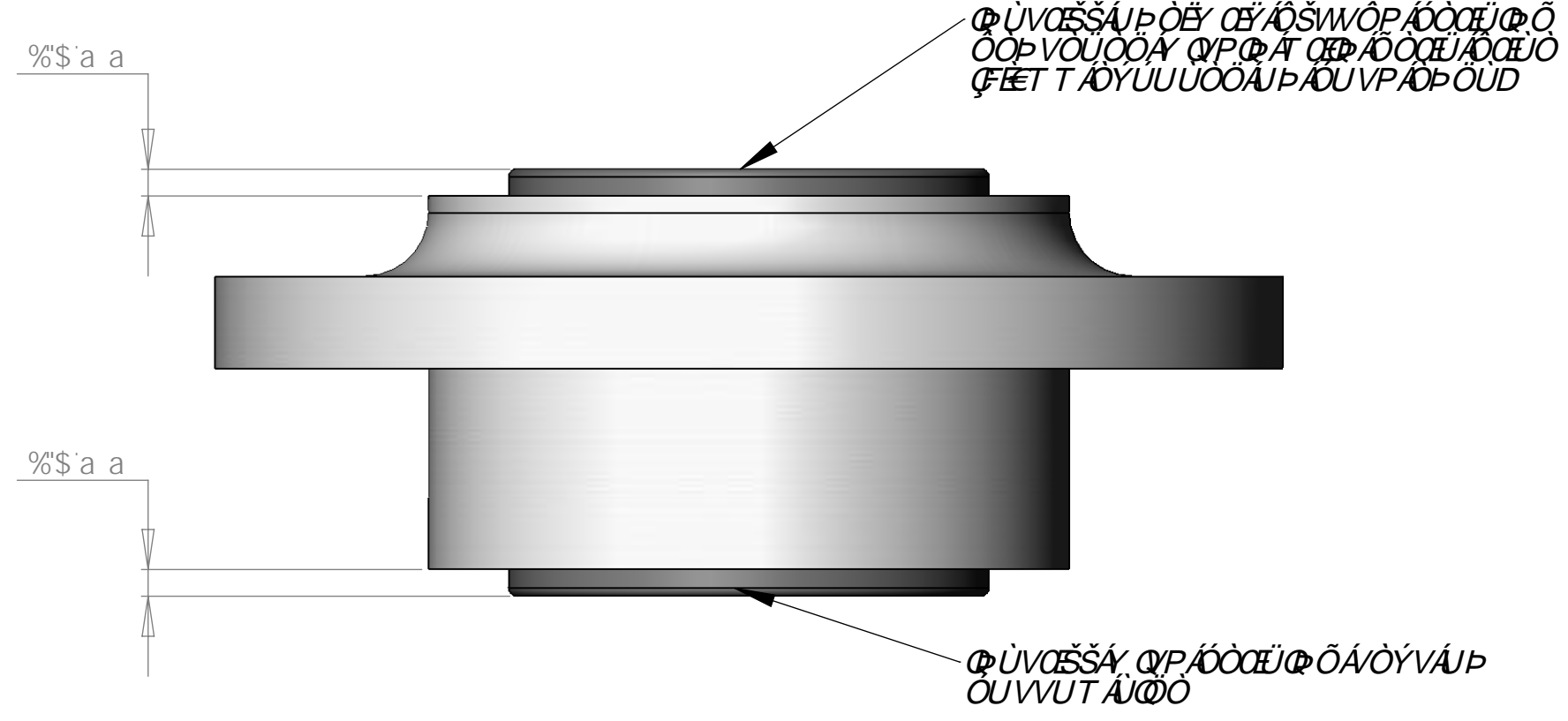

BCH9A P O A T C P A O C E J A C E I O P C E I A O O P A O O U P O O A U U C E A
 U U V G C S A J U O U U E Q V O V Y O O P A P O A P O U A O U O A P O A P O A
 U P O E Y C E A O S W O P A O C E U P O A V A K E D A P A O C E J O A K E J U O T O S Y B A
 V U A J U O X O P V A S O J U C E O A W U P O A O S O P V E C E J U S Y A J O O A J U A
 O U O P S U O V O A C E C E G F E G I E A U A I E D V U A P O A P O U A O U U O A
 U O A P O A T C P A O C E J A C E I O A O O U J O A K E J U O T O S Y A O U A P U V A
 C S S U Y A P Y A S U O V O A U O P V O U A P O A O C E U P O A O S W O P A
 U P O A J U U O U S Y A P U V O S S O A F T T A O Y U U U O O A P A O U V P A O P O U A
 C E I A I P U Y P A P A O C E J U C E I A Y Q I O A Y C E A P Y A O Y O O U U S U O V O A
 C E O A C S S U Y A P O A K E J U O T O S Y A U A O W U O A U U F P U W U A O O U U O A
 O S O P V E

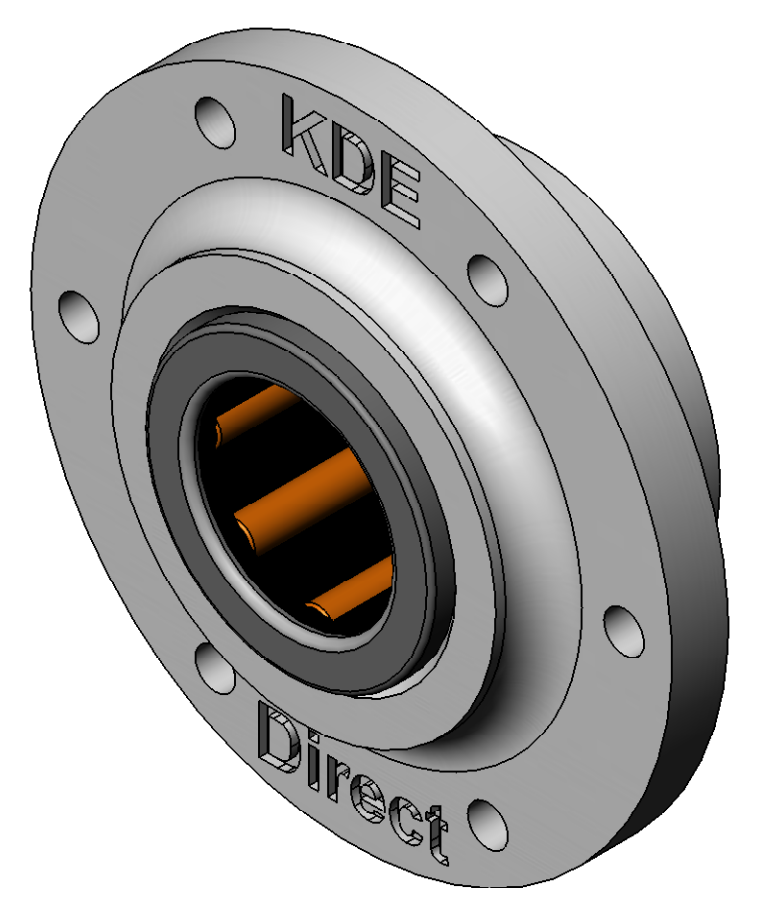
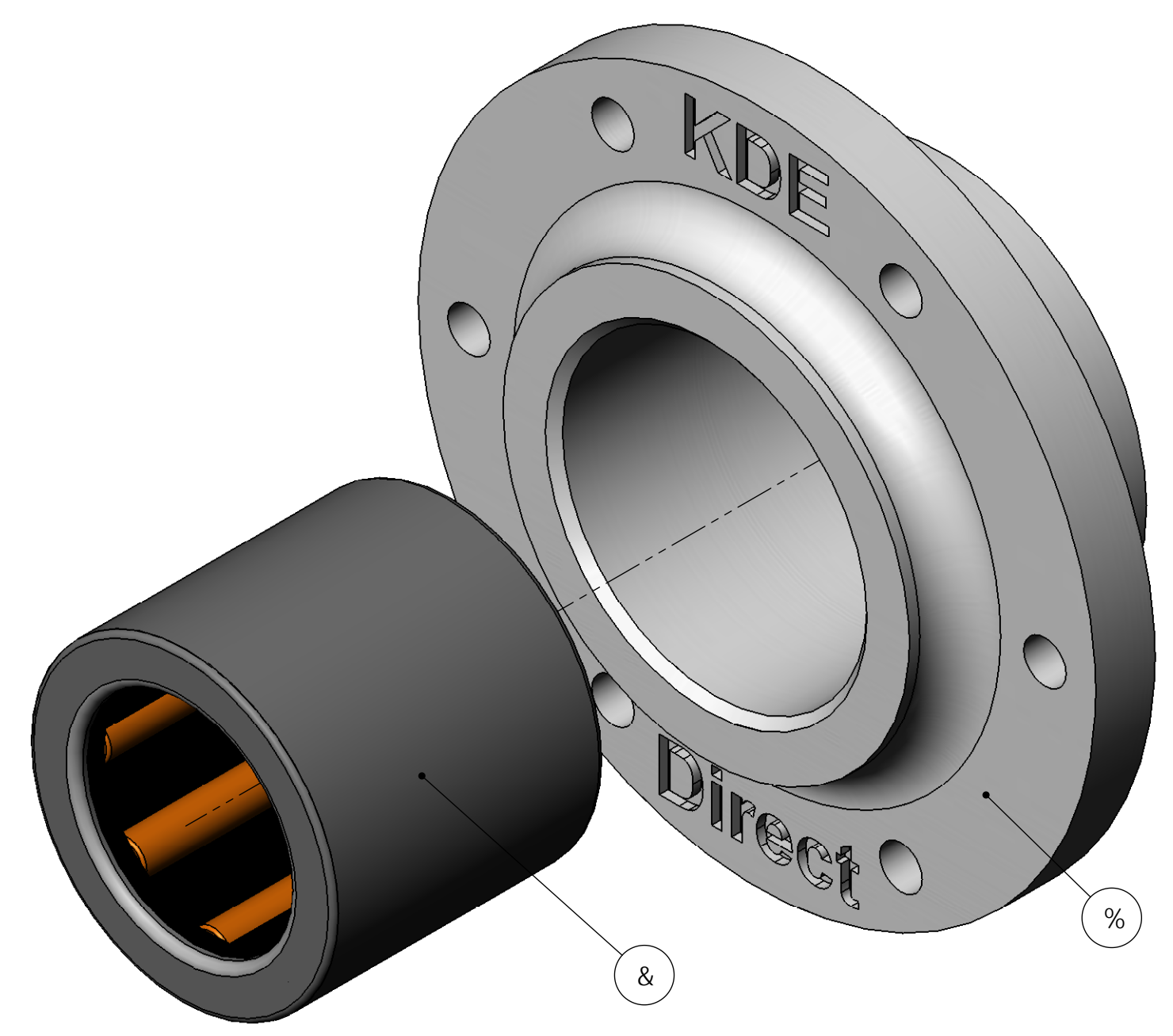

KDEDirect
 K k k " ? 8 9 8 J f Y W W t a
 k k k " ? 8 9 8 J f Y W W t a
 5 H * \$ \$! A ; 7