

TREX550/600 SERIES PERFORMANCE TAIL CONTROL UPGRADE AT550/600-PTC (AL 6061-T6)

STEP 1

DISASSEMBLE STOCK ALIGN METAL TAIL PITCH ASSEMBLIES

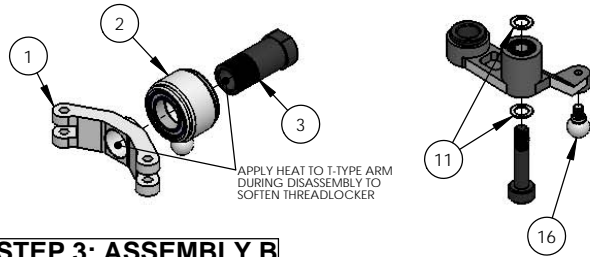

STEP 2: ASSEMBLY A

ASSEMBLE PERFORMANCE TAIL PITCH ASSEMBLY

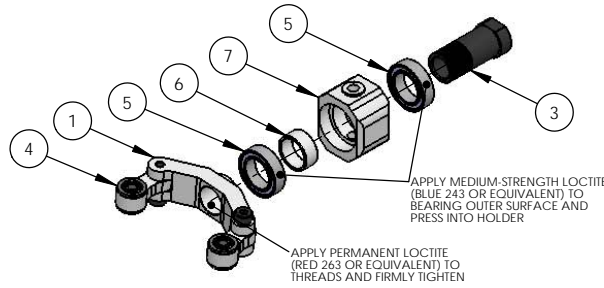

STEP 3: ASSEMBLY B

ASSEMBLE SECONDARY LINK MECHANICS

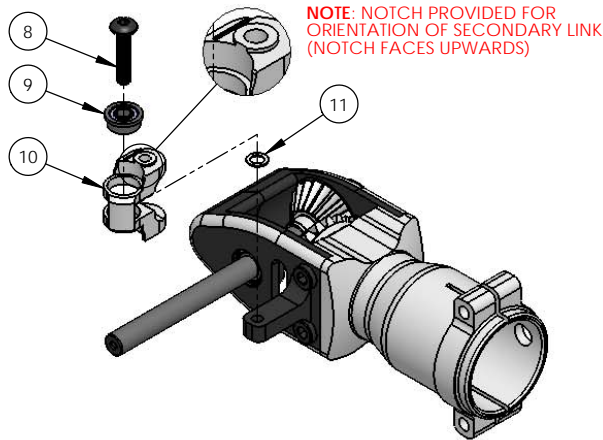

STEP 4: ASSEMBLY B

ASSEMBLE SECONDARY LINK MECHANICS

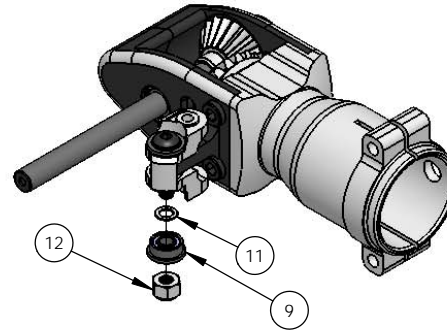

STEP 5: ASSEMBLY B

ASSEMBLE PRIMARY LINK MECHANICS

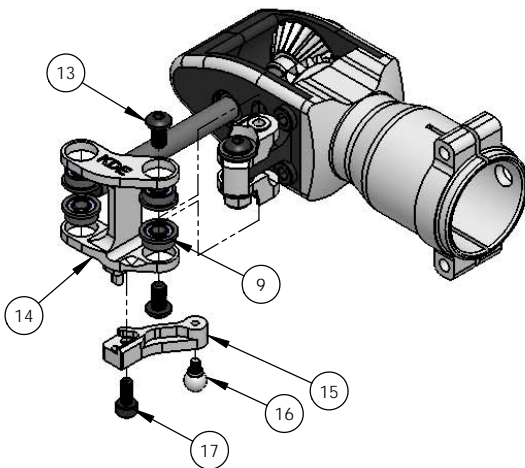

STEP 6

ASSEMBLE INTO TREX 550/600 SERIES TAIL SYSTEM

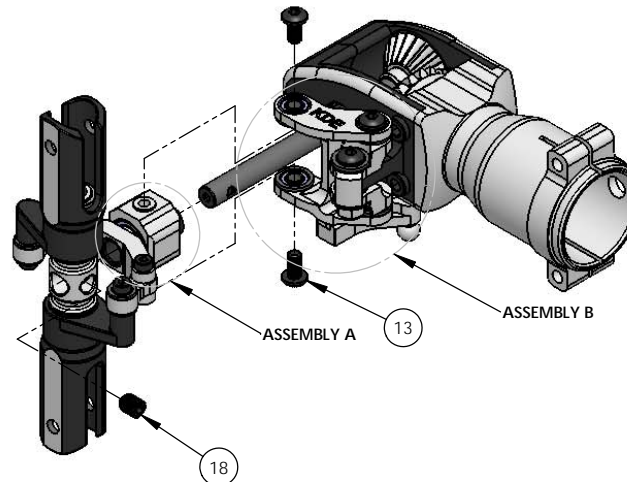

ITEM NO.	DESCRIPTION	QTY.
1	ALIGN TREX 550/600 SERIES T-TYPE ARM (INCLUDED IN ORIGINAL KIT)	1
2	ALIGN TREX 550/600 SERIES BEARING HOLDER ASSEMBLY (INCLUDED IN ORIGINAL V2/PRO KIT, REQUIRES H60077A)	1
3	ALIGN TREX 550/600 SERIES SLIDE SHAFT (INCLUDED IN ORIGINAL V2/PRO KIT, REQUIRES H60077A OR H60238)	1
4	KDE DIRECT TREX 550/600/700 SERIES PERFORMANCE TAIL UPGRADE V2 (SOLD SEPARATELY, AT550/600/700-PTU-V2)	2
5	MR117ZZ RADIAL BALL BEARING	2
6	KDE DIRECT TREX 550/600 SERIES PERFORMANCE TAIL CONTROL BEARING COLLAR	1
7	KDE DIRECT TREX 550/600 SERIES PERFORMANCE TAIL CONTROL BEARING HOLDER	1
8	M3 x 0.5 x 14MM BUTTON HEAD SOCKET HEAD CAP SCREW	1
9	F683ZZ FLANGED RADIAL BALL BEARING	6
10	KDE DIRECT TREX 550/600 SERIES PERFORMANCE TAIL CONTROL SECONDARY LINK	1
11	ALIGN M3 SHIM WASHER (3.0 x 4.8 x 0.3MM) (INCLUDED IN ORIGINAL KIT)	2
12	M3 x 0.5 NYLON INSERT HEX LOCKNUT ALLOY STEEL	1
13	M3 x 0.5 x 6MM BUTTON HEAD SOCKET HEAD CAP SCREW	4
14	KDE DIRECT TREX 550/600 SERIES PERFORMANCE TAIL CONTROL PRIMARY LINK	1
15	KDE DIRECT TREX 550/600 SERIES PERFORMANCE TAIL CONTROL ARM LEVER	1
16	ALIGN TREX 550/600 SERIES LINKAGE BALL A (M2 x 3.5MM) (INCLUDED IN ORIGINAL KIT)	1
17	M2.5 x 0.45 x 6MM SOCKET HEAD CAP SCREW	1
18	M4 x 0.7 x 4MM SOCKET HEAD SET SCREW CUP POINT (INCLUDED IN ORIGINAL KIT)	1

NOTE: THE TREX 550/600 PERFORMANCE TAIL CONTROL UPGRADE PROVIDES THE ULTIMATE, SLOP-FREE CONTROL SYSTEM AVAILABLE ON THE MARKET TO PROVIDE PRECISE TAIL CONTROL AND AUTHORITY. DUE TO THE PRECISION CNC-MACHINING OF EACH COMPONENT, CORRECT INSTALLATION IS KEY FOR PROPER, BIND-FREE OPERATION. PLEASE PAY ATTENTION TO THE INSTRUCTIONS AND TAKE YOUR TIME WHEN INSTALLING THE ASSEMBLY. **MAKE SURE TO APPLY MEDIUM-STRENGTH LOCTITE (BLUE 243 OR EQUIVALENT) TO ALL SCREWS AND OUTER SURFACE OF RADIAL BALL BEARINGS DURING ASSEMBLY. IN ADDITION, LEAVE ALL SCREWS LOOSELY INSTALLED UNTIL STEP 6.**

STEP 1: DISASSEMBLE THE STOCK ALIGN METAL TAIL PITCH ASSEMBLIES TO REMOVE THE STOCK BEARING HOLDER AND CONTROL ARM. USING A HEAT-GUN, FLAME, OR ALTERNATE HEAT-SOURCE, APPLY HEAT TO THE THREADS HOLDING THE SLIDE SHAFT TO THE T-TYPE ARM. ONCE THE LOCTITE HAS SOFTENED AND RELEASED, UNSCREW THE SLIDE SHAFT FROM THE T-TYPE ARM AND SET ASIDE.

STEP 2: ASSEMBLE THE PERFORMANCE TAIL PITCH ASSEMBLY AS SHOWN IN THE DIAGRAM. APPLY MEDIUM-STRENGTH LOCTITE (BLUE 243 OR EQUIVALENT) TO THE OUTER SURFACE OF THE MR117ZZ RADIAL BALL BEARINGS AND PERMANENT LOCTITE (RED 263 OR EQUIVALENT) TO THE THREADS OF THE SLIDE SHAFT DURING INSTALLATION. TIGHTEN THE SLIDE SHAFT FIRMLY TO ACCURATELY SEAT THE RADIAL BALL BEARINGS INTO THE HOLDER AND PROVIDE A SLOP-FREE HOLD.

STEP 3: ASSEMBLE THE PERFORMANCE TAIL CONTROL SECONDARY LINK AS SHOWN IN THE DIAGRAM, WITH THE M3 SHIM WASHER INSTALLED BETWEEN THE MOUNTING ARM AND THE F683ZZ FLANGED RADIAL BALL BEARING.

STEP 4: INSTALL THE SECOND M3 SHIM WASHER BETWEEN THE MOUNTING ARM AND THE LOWER F683ZZ FLANGED RADIAL BALL BEARING, AND HAND-PRESSURE TIGHTEN THE M3 LOCKNUT TO LOCK DOWN THE ASSEMBLY (CLEARANCE IS PROVIDED FOR USE OF A NUT DRIVER AND HEX WRENCH FOR EASY INSTALLATION).

STEP 5: ASSEMBLE THE PERFORMANCE TAIL CONTROL PRIMARY LINK AS SHOWN IN THE DIAGRAM. INSTALL THE M3 BUTTON HEAD SOCKET HEAD CAP SCREWS AND M2.5 SOCKET HEAD CAP SCREW AS SHOWN (LEAVE M3 SCREWS LOOSELY INSTALLED).

STEP 6: INSTALL BOTH ASSEMBLIES AND CHECK FOR SMOOTH OPERATION OF ALL COMPONENTS. PROCEED TO TIGHTEN ALL SCREWS TO COMPLETE INSTALLATION AND ENJOY THE NEW SLOP-FREE AND PRECISION-CONTROL TAIL SYSTEM.