

HF9L) \$\$'6CHCA '6F57?9HI D; F589
 5H) \$\$!661 'f5 @* \$* %H* L

#9A 'BC'	89G7F-DHCB	EHM'
*	T GE A AE I A ET T UU OSOVP OCE A OCE A U O U O Y A ESSU YA NV O OS	I
)	T GE A AE I A ET T UU OSOVP OCE A OCE A U O U O Y A ESSU YA NV O OS	G
.	T GE A AE I A ET T UU OSOVP OCE A OCE A U O U O Y A ESSU YA NV O OS	I
%	QESOPAT GE AUU O O QESVYA CE POU QUUXW O O A P AU U O QESASQD	I
&	QESOPAT GE ASCEVA CE POU QUUXW O O A P AU U O QESASQD	G
*	QESOPAT G O SCEVA CE POU QUUXW O O A P AU U O QESASQD	I

BCH9 K O W O A U A U S O U C E O O O U P V U U S A U O A P O A U V U O S A
 O U C E O U E S O P V A U C E O O O A U O A P O A U C E O A U A O U S S O O A
 U O A P O A U C E O P U S O S U O C E O P U A T C E Y A O O P O O O U U C E Y A
 V U A U U X W O O A O O W U C E O A C E O P T O P V E



BCH9 K O W O A U A U S O U C E O O O U P V U U S A U O A P O A U V U O S A
 O U C E O U E S O P V A U C E O O O A U O A P O A U C E O A U A O U S S O O A
 U O A P O A U C E O P U S O S U O C E O P U A T C E Y A O O P O O O U U C E Y A
 O O U V C E P A O C E U U O U A U A O O A U U U O U S Y A P V U A P O A O S Q E A

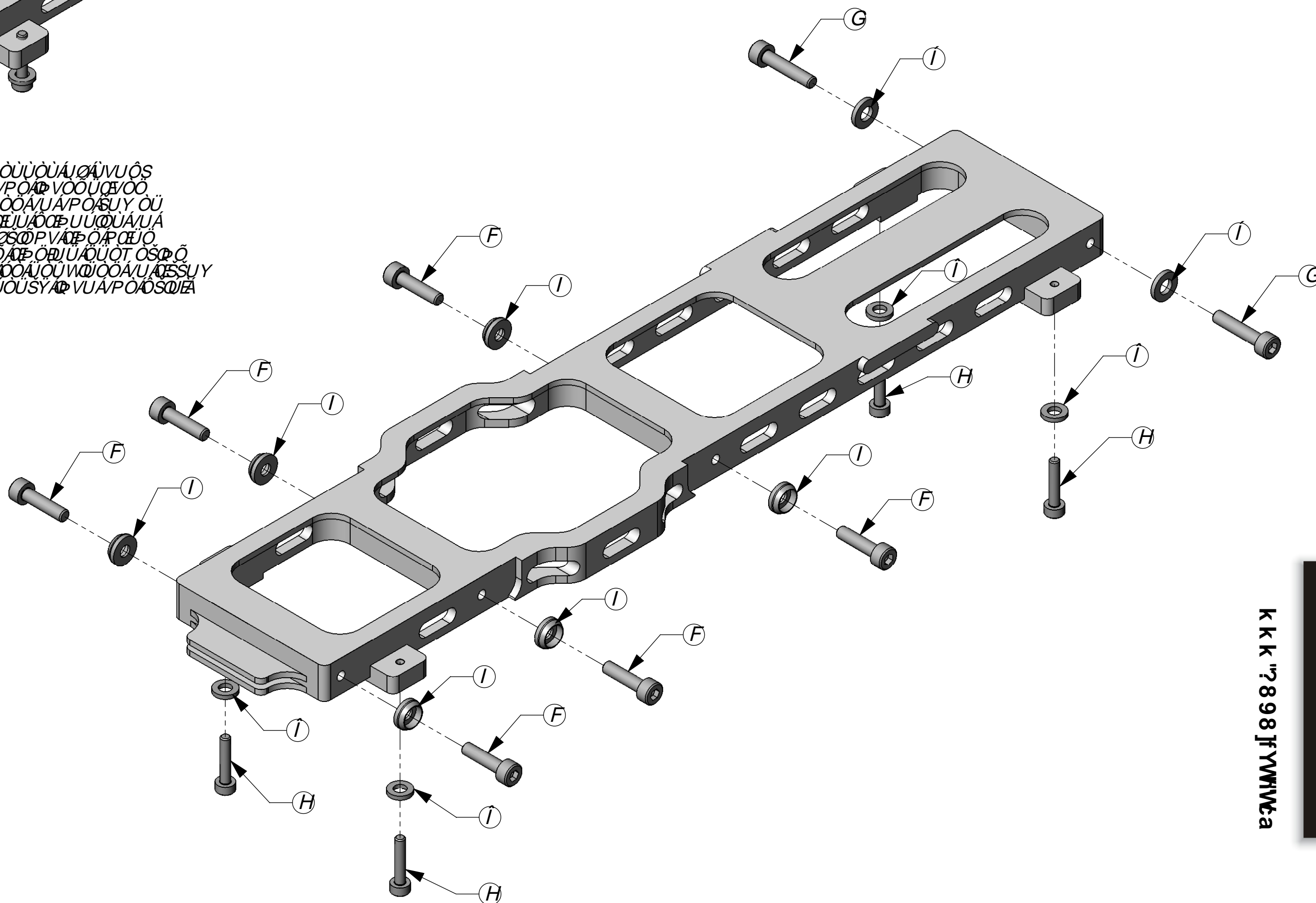

k k k ' ? 8 9 8 J f Y W W t a

k k k ' ? 8 9 8 J f Y W W t a
 5H) \$\$!661