

# T-REX 250<sup>PRO</sup> Super Combo

KX0190010T

## INSTRUCTION MANUAL

## 使用說明書

# ALIGN



Contents	
1	INTRODUCTION 前言
1~2	SAFETY NOTES 安全注意事項
3	EQUIPMENT REQUIRED FOR ASSEMBLY 自備設備
3	PACKAGE ILLUSTRATION 包裝說明
4	SAFETY CHECK BEFORE FLYING 飛行前安全檢查重要事項
5~16	ASSEMBLY SECTION 組裝說明
17	GYRO INSTALLATION SUGGESTION 陀螺儀安裝建議位置
17	CANOPY ASSEMBLY 機頭罩安裝
17	DIAL PITCH GAUGE PAD INSTRUCTION 可調式螺距規墊塊使用說明
18	EQUIPMENT ILLUSTRATION 設備建議配置圖示
19	SERVO SETTING AND ADJUSTMENT 伺服器設定調整
19	ADJUSTMENTS FOR GYRO AND TAIL NEUTRAL SETTING 陀螺儀與尾翼中立點調整
20	PITCH AND THROTTLE SETTING 主旋翼螺距與油門設定
21	POWER COLLOCATION REFERENCE 原裝動力數據參考表
21~24	RCE-BL15X BRUSHLESS SPEED CONTROLLER INSTRUCTION MANUAL 無刷調速器使用說明
24~27	GP790 HEAD LOCK GYRO SET USER MANUAL GP790鎖定式陀螺儀組使用說明
28~30	FLIGHT ADJUSTMENT AND SETTING 飛行動作調整與設定

Thank you for buying ALIGN products. The **T-REX 250 PRO** is the latest technology in Rotary RC models. Please read this manual carefully before assembling and flying the new **T-REX 250 PRO** helicopter. We recommend that you keep this manual for future reference regarding tuning and maintenance.

承蒙閣下選用亞拓遙控世界系列產品，謹表謝意。進入遙控世界之前必須告訴您許多相關的知識與注意事項，以確保您能夠在學習的過程中較得心應手。在開始操作之前，請務必詳閱本說明書，相信一定能夠給您帶來相當大的幫助，也請您妥善保管這本說明書，以作為日後參考。

Thank you for buying ALIGN Products. The T-REX 250 PRO Helicopter is designed as an easy to use, full featured Helicopter R/C model capable of all forms of rotary flight. Please read the manual carefully before assembling the model, and follow all precautions and recommendations located within the manual. Be sure to retain the manual for future reference, routine maintenance, and tuning. The T-REX 250 PRO is a new product developed by ALIGN.

It features the best design available on the Micro-Heli market to date, providing flying stability for beginners, full aerobatic capability for advanced fliers, and unsurpassed reliability for customer support.

感謝您選購亞拓產品，為了讓您容易方便的使用 T-REX 250 PRO直昇機、請您詳細的閱讀完這本說明書之後再進行組裝以及操作這台直昇機，同時請您妥善的保存這本說明書、作為日後進行調整以及維修的參考。T-REX 250 PRO是由亞拓自行研發的新產品，不論您是需求飛行穩定性的初學者或是追求性能的飛行愛好者。T-REX 250 PRO將是您最佳的選擇。

#### WARNING LABEL LEGEND 標誌代表涵義

 <b>WARNING</b> 警告	<b>Mishandling due to failure to follow these instructions may result in damage or injury.</b> 因為疏忽這些操作說明，而使用錯誤可能造成財產損失或嚴重傷害。
 <b>CAUTION</b> 注意	<b>Mishandling due to failure to follow these instructions may result in danger.</b> 因為疏忽這些操作說明，而使用錯誤可能造成危險。
 <b>FORBIDDEN</b> 禁止	<b>Do not attempt under any circumstances.</b> 在任何禁止的環境下，請勿嘗試操作。

#### IMPORTANT NOTES 重要聲明

R/C helicopters, including the T-REX 250 PRO are not toys. R/C helicopter utilize various high-tech products and Technologies to provide superior performance. Improper use of this product can result in serious injury or even death. Please read this manual carefully before using and make sure to be conscious of your own personal safety and the safety of others and your environment when operating all ALIGN products.

Manufacturer and seller assume no liability for the operation or the use of this product.

Intended for use only by adults with experience flying remote control helicopters at a legal flying field. After the sale of this product we cannot maintain any control over its operation or usage.

T-REX 250 PRO遙控直昇機並非玩具，它是結合了許多高科技產品所設計出來的休閒用品，所以商品的使用不當或不熟悉都可能造成嚴重傷害甚至死亡，使用之前請務必詳讀本說明書，勿輕忽並注意自身安全。注意！任何遙控直昇機的使用，製造商和經銷商是無法對使用者於零件使用的損耗異常或組裝不當所發生之意外負任何責任，本產品是提供給有操作過模型直昇機經驗的成人或有相當技術的人員在旁指導於當地合法遙控飛行場飛行，以確保安全無虞下操作使用，產品售出後本公司將不負任何操作和使用控制上的任何性能與安全責任。

We recommend that you obtain the assistance of an experienced pilot before attempting to fly our products for the first time. A local expert is the best way to properly assemble, setup, and fly your model for the first time. The T-REX 250 PRO requires a certain degree of skill to operate, and is a consumer item. Any damage or dissatisfaction as a result of accidents or modifications are not covered by any warrantee and cannot be returned for repair or replacement. Please contact our distributors for free technical consultation and parts at discounted rates when you experience problems during operation or maintenance.

模型商品屬於需高操作技術且為消耗性之商品，如經拆裝使用後，會造成不等情況零件損耗，任何使用情況所造成商品不良或不滿意，將無法於保固條件內更換新品或退貨，如遇有使用操作維修問題，本公司全省分公司或代理商將提供技術指導、特價零件供應服務。

## 2. SAFETY NOTES 安全注意事項



**Fly only in safe areas, away from other people. Do not operate R/C aircraft within the vicinity of homes or crowds of people. R/C aircraft are prone to accidents, failures, and crashes due to a variety of reasons including, lack of maintenance, pilot error, and radio interference. Pilots are responsible for their actions and damage or injury occurring during the operation or as of a result of R/C aircraft models.**

遙控模型飛機、直昇機屬高危險性商品，飛行時務必遠離人群，人為組裝不當或機件損壞、電子控制設備不良，以及操控上的不熟悉、都有可能導致飛行失控損傷等不可預期的意外，請飛行者務必注意飛行安全，並需了解自負疏忽所造成任何意外之責任。



### LOCATE AN APPROPRIATE LOCATION 遠離障礙物及人群

R/C helicopters fly at high speed, thus posing a certain degree of potential danger. Choose an a legal flying field consisting of flat, smooth ground without obstacles. Do not fly near buildings, high voltage cables, or trees to ensure the safety of yourself, others and your model. For the first practice, please choose a legal flying field and can use a training skid to fly for reducing the damage. Do not fly your model in inclement weather, such as rain, wind, snow or darkness.

直昇機飛行時具有一定的速度，相對的也潛在著危險性，場地的選擇也相對的重要，請需遵守當地法規到合法遙控飛行場地飛行。必須注意周遭有沒有人、高樓、建築物、高壓電線、樹木等等，避免操控的不當造成自己與他人財產的損壞。初次練習時，務必選擇在空曠合法專屬飛行場地並適當搭配練習架練習飛行，這對飛行失誤所造成的損傷將會大幅的降低。請勿在下雨、打雷等惡劣天候下操作，以確保本身及機體的安全。



### PREVENT MOISTURE 遠離潮濕環境

R/C models are composed of many precision electrical components. It is critical to keep the model and associated equipment away from moisture and other contaminants. The introduction or exposure to water or moisture in any form can cause the model to malfunction resulting in loss of use, or a crash. Do not operate or expose To rain or moisture.

直昇機內部也是由許多精密的電子零組件組成，所以必須絕對的防止潮濕或水氣，避免在浴室或雨天時使用，防止水氣進入機身內部而導致機件及電子零件故障而引發不可預期的意外！

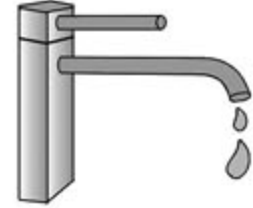

### PROPER OPERATION 勿不當使用本產品

Please use the replacement of parts on the manual to ensure the safety of instructors. This product is for R/C model, so do not use for other purpose.

請勿自行改造加工，任何的升級改裝或維修，請使用亞拓產品目錄中的零件，以確保結構的安全。請確認於產品限界內操作，請勿過載使用，並勿用於安全、法令外其它非法用途。

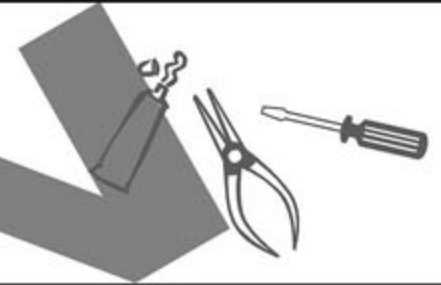

### OBTAIN THE ASSISTANCE OF AN EXPERIENCED PILOT 避免獨自操控

Before turning on your model and transmitter, check to make sure no one else is operating on the same frequency. Frequency interference can cause your model, or other models to crash. The guidance provided by an experienced pilot will be invaluable for the assembly, tuning, trimming, and actual first flight. (Recommend you to practice with computer-based flight simulator.)

至飛行場飛行前，需確認是否有相同頻率的同好正進行飛行，因為開啓相同頻率的發射機將導致自己與他人立即干擾等意外危險。遙控飛機操控技巧在學習初期有著一定的難度，要盡量避免獨自操作飛行，需有經驗的人士在旁指導，才可以操控飛行。(勤練電腦模擬器及老手指導是入門必要的選擇)



### SAFE OPERATION 安全操作

Operate this unit within your ability. Do not fly under tired condition and improper operation may cause in danger.

請於自己能力內及需要一定技術範圍內操作這台直昇機，過於疲勞、精神不佳或不當操作，意外發生風險將可能會提高。



### ALWAYS BE AWARE OF THE ROTATING BLADES 遠離運轉中零件

During the operation of the helicopter, the main rotor and tail rotor will be spinning at a high rate of speed. The blades are capable of inflicting serious bodily injury and damage to the environment. Be conscious of your actions, and careful to keep your face, eyes, hands, and loose clothing away from the blades. Always fly the model a safe distance from yourself and others, as well as surrounding objects. Never take your eyes off the model or leave it unattended while it is turned on. Immediately turn off the model and transmitter when you have landed the model.

當直昇機主旋翼與尾旋翼運轉時，切勿觸摸並遠離任何物件，以避免造成危險及損壞。



### KEEP AWAY FROM HEAT 遠離熱源

R/C models are made of various forms of plastic. Plastic is very susceptible to damage or deformation due to extreme heat and cold climate. Make sure not to store the model near any source of heat such as an oven, or heater. It is best to store the model indoors, in a climate-controlled, room temperature environment.

遙控飛機多半是以 PA 纖維或聚乙烯、電子商品為主要材質，因此要盡量遠離熱源、日曬，以避免因高溫而變形甚至熔毀損壞的可能。



### 3.EQUIPMENT REQUIRED FOR ASSEMBLY 自備設備

ALIGN

#### RADIO TRANSMITTER AND ELECTRONIC EQUIPMENT REQUIRED FOR ASSEMBLY 自備遙控及電子設備



**Transmitter**  
(6-channel or more, helicopter system)  
發射機 (六動以上直昇機模式遙控器)



**Receiver(6-channel or more)**  
接收機 (六動以上)



**11.1V 3S 850mAh Li-Po Battery x 1pc**  
11.1V 3S 850mAh Li-Po電池 x 1



**Dial Pitch Gauge x 1pc**  
旋轉式螺距規 x 1



**or Digital Pitch Gauge x 1pc**  
或 電子螺距規 x 1

#### ADDITIONAL TOOLS REQUIRED FOR ASSEMBLY 自備工具



**Scissors**  
剪刀



**Cutter Knife**  
刀子



**Diagonal Cutting Pliers**  
斜口鉗



**Needle Nose Pliers**  
尖嘴鉗



**Oil**  
潤滑油



**CA**  
瞬間膠



**R48**  
軸承膠

### 4.PACKAGE ILLUSTRATION 包裝說明

ALIGN

205 Main Blade x 1set  
205主旋翼 x 1組  
205D Carbon Fiber Blades x 1set  
205D碳纖主旋翼 x 1組

**RCE-BL15X Brushless ESC x 1**  
RCE-BL15X 15安培無刷調速器 x 1  
**RCM-BL250SP 3400KV Brushless motor x 1**  
RCM-BL250SP 3400KV無刷馬達 x 1  
**DS410 Digital Servo x 3**  
Ds410數位伺服器 x 3  
**GP790 Gyro**  
GP790鎖定式陀螺儀  
**DS420 Digital Servo x 1**  
Ds420數位伺服器 x 1

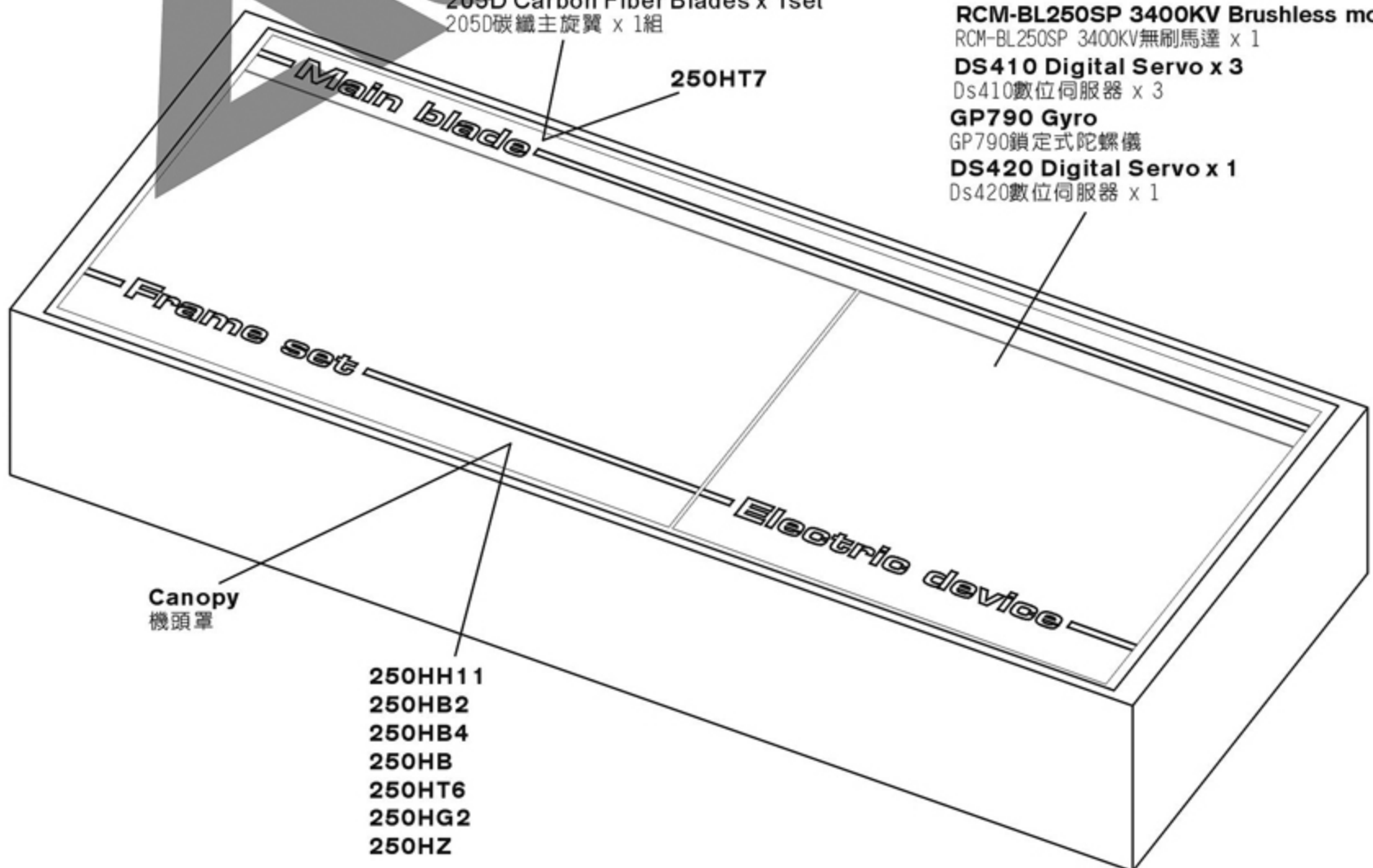

250HH11  
250HB2  
250HB4  
250HB  
250HT6  
250HG2  
250HZ

## CAREFULLY INSPECT BEFORE REAL FLIGHT 請嚴格執行飛行前檢查義務

- ☆ Before flying, please check to make sure no one else is operating on the same frequency for the safety.
  - ☆ Before flight, please check if the batteries of transmitter and receiver are enough for the flight.
  - ☆ Before turn on the transmitter, please check if the throttle stick is in the lowest position. IDLE switch is OFF.
  - ☆ When turn off the unit, please follow the power on/off procedure. Power ON- Please turn on the transmitter first, and then turn on receiver. Power OFF- Please turn off the receiver first and then turn off the transmitter. Improper procedure may cause out of control, so please to have this correct habit.
  - ☆ Before operation, check every movement is smooth and directions are correct. Carefully inspect servos for interference and broken gear.
  - ☆ Check for missing or loose screws and nuts. See if there is any cracked and incomplete assembly of parts. Carefully check main rotor blades and rotor holders. Broken and premature failures of parts possibly cause resulting in a dangerous situation.
  - ☆ Check all ball links to avoid excess play and replace as needed. Failure to do so will result in poor flight stability.
  - ☆ Check the battery and power plug are fastened. Vibration and violent flight may cause the plug loose and result out of control.
- ★每次飛行前應先確認所使用的頻率是否會干擾他人，以確保您自身與他人的安全。
- ★每次飛行前確定您發射機與接收機電池的電量是在足夠飛行的狀態。
- ★開機前確認油門搖桿是否位於最低點，熄火降落開關，定速開關(IDLE)是否於關閉位置。
- ★關機時必須遵守電源開關機的程序，開機時應先開啓發射機後，再開啓接收機電源；關機時應先關閉接收機後，再關閉發射機電源。不正確的開關程序可能會造成失控的現象，影響自身與他人的安全，請養成正確的習慣。
- ★開機請先確定直昇機各個動作是否順暢，及方向是否正確，並檢查伺服器的動作是否有干涉或崩齒的情形，使用故障的伺服器將導致不可預期的危險。
- ★飛行前確認沒有缺少或鬆脫的螺絲與螺帽，確認沒有組裝不完整或損毀的零件，仔細檢查主旋翼是否有損壞，特別是接近主旋翼夾座的部位。損壞或組裝不完整的零件不僅影響飛行，更會造成不可預期的危險。注意：對損耗、有裂痕零件更新及定期保養檢查的重要性。
- ★檢查所有的連桿頭是否有鬆脫的情形，過鬆的連桿頭應先更新，否則將造成直昇機無法操控的危險。
- ★確認電池及電源接頭是否固定牢靠，飛行中的震動或激烈的飛行，可能造成電源接頭鬆脫而造成失控的危險。

Standard Equipment 標準配備					
<b>250HC3</b>	<b>250HH11</b>	<b>250HB4</b>	<b>250HB2</b>	<b>250HT6</b>	<b>250HT7</b>
<b>250HG2</b>	<b>250HZ</b>	<b>250HB</b>	<b>15T x 1</b> Motor Pinion Gear x 1 pc 馬達主齒 x 1	<b>RCM-BL250SP 3400KV Brushless motor x 1</b> RCM-BL250SP 3400KV 無刷馬達 x 1	<b>RCE-BL15X Brushless ESC x 1</b> RCE-BL15X 15安培無刷調速器 x 1
<b>205D Carbon Fiber Blades x 1set</b> 205D碳纖主旋翼 x 1	<b>205 Main Blade x 1set</b> 205主旋翼 x 1	<b>DS410 Digital Servo x 3</b> DS410數位伺服器 x 3	<b>GP790 Head Lock Gyro Combo</b> GP790鎖定式陀螺儀組 (GP790+DS420)	<b>Dial Pitch Gauge Pad x 1</b> 可調式螺距規墊塊 x 1	

When you see the marks as below, please use glue or grease to ensure flying safety.

標有下符號之組裝步驟，請配合上膠或上油，以確保使用之可靠度。



- CA: Apply CA Glue to fix.**
  - R48: Apply Anaerobics Retainer to fix.**
  - T22: Apply Thread Lock to fix.**
  - OIL: Add Grease.**
- CA: 使用瞬間膠固定  
R48: 使用金屬管狀固定缺氧膠固定  
T22: 使用螺絲膠  
OIL: 添加潤滑油

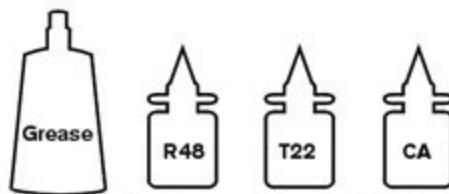

Self-grease Self-green Purple Self-furnished  
潤滑油(自備) 綠色(自備) 紫色 瞬間膠(自備)



T22 Glue width: approx. 1mm  
T22上膠寬度約1mm

R48 metal tubular adhesive (eg. Bearings). T22 thread lock, apply a small amount on screws or metal parts and wipe surplus off. When disassembling, recommend to heat the metal joint about 15 Seconds.

(NOTE: Keep plastic parts away from heat.)

R48 為強力金屬管狀(如軸承)接著劑，T22為螺絲膠，膠合螺絲或金屬內外徑請務必少量使用，必要時請用手去除多餘膠量，欲拆卸時可於金屬接合部位熱烤約15秒。(注意！塑膠件避免接近熱源)

When assembling ball links, make sure the "A" character faces outside.

各項塑膠製連桿頭扣接時，A字請朝外。

250HH11



**Bearing**  
軸承(φ 1.5xφ 4x1.2mm) x 4



**Socket button head collar screw**  
半圓頭內六角軸套螺絲(0#x4mm) x 2



**CAUTION 注意**  
For original manufactory package, if the product is already assembled by Factory, please check again if screws are firmly secured and applied with some glue.

原廠零件出廠包裝如果是組裝品，請需再確認各螺絲是否鎖緊上膠。

Apply a little amount of T22 thread lock when fixing a metal part.  
螺絲鎖附於金屬件請使用適量T22(螺絲膠)

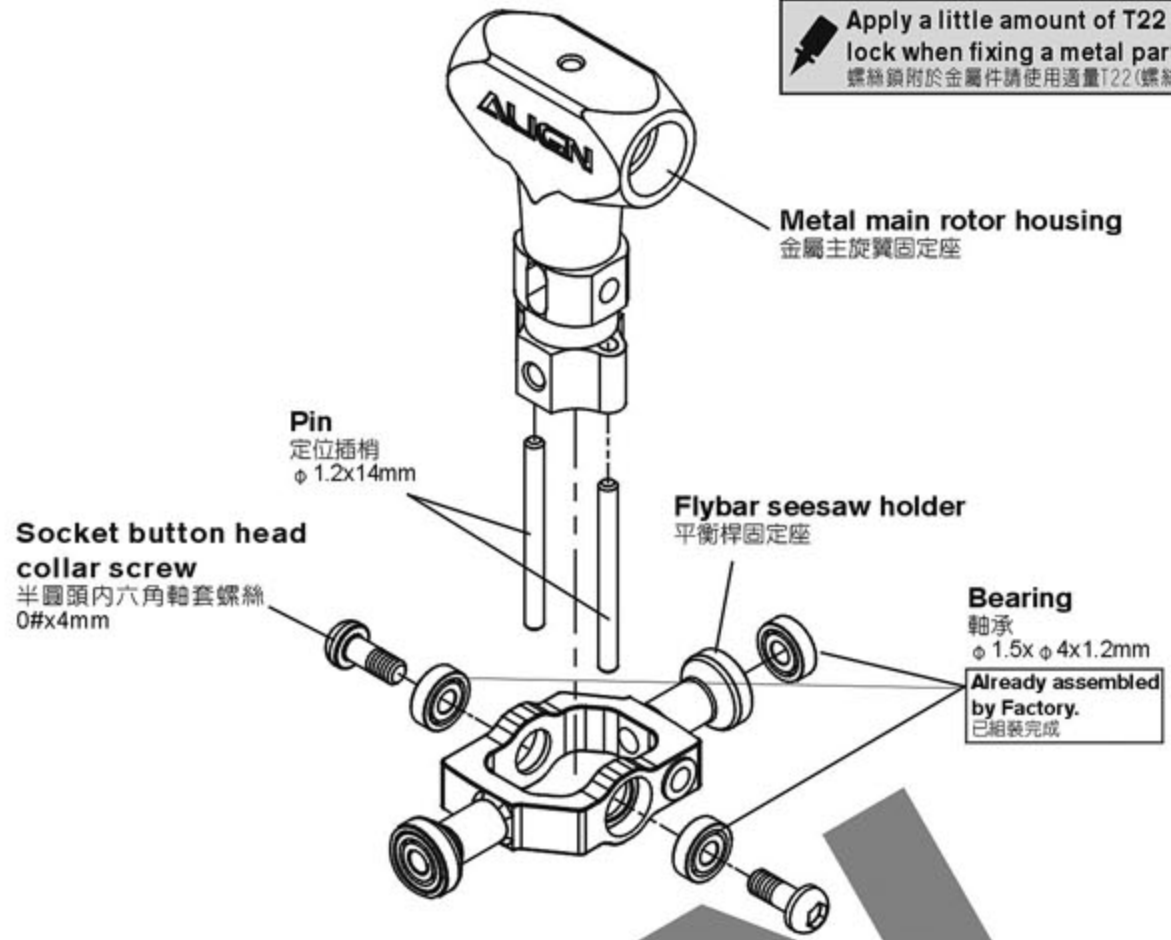

250HH11

**Linkage ball A(0#x2)**  
球頭A(0#x2)(φ 3.5x5.3mm) x 4

**Socket button head screw**  
半圓頭內六角螺絲(0#x6mm) x 2

**Washer**  
華司(φ 1.5xφ 3x0.5mm) x 2

**Bearing**  
軸承(φ 1.5xφ 4x1.2mm) x 2

**Bearing**  
軸承(φ 1.5xφ 4x2mm) x 2

250HH13

**Socket button head screw**  
半圓頭內六角螺絲(0#x3mm) x 4

**M2 Set screw**  
M2止洩螺絲(M2x2mm) x 2

250HZ12

**Ball link B**  
連桿頭B x 2

250HT7

**M2 Set screw**  
M2止洩螺絲  
M2x2mm

**Flybar rod**  
平衡翼桿  
φ 1.5x152mm

**Bearing**  
軸承  
φ 1.5xφ 4x2mm

**Washer**  
華司  
φ 1.5xφ 3x0.5mm

**Bearing**  
軸承  
φ 1.5xφ 4x1.2mm  
Already assembled by Factory.  
已組裝完成

**Socket button head screw**  
半圓頭內六角螺絲  
0#x6mm

**Metal flybar control arm**  
金屬平衡翼控制臂  
23x5.2mm

**Flybar control rod**  
平衡翼控制球桿  
φ 3x27.1mm

**Metal SF Mixing arm**  
金屬SF控制搖臂

**Socket button head screw**  
半圓頭內六角螺絲  
0#x3mm

**Linkage ball A(0#x2)**  
球頭A(0#x2)  
φ 3.5x5.3mm

**Ball link B**  
連桿頭B

**Words face outside**  
字體請朝外

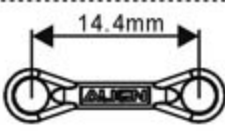



**For original manufactory package, if the product is already assembled by Factory, please check again if screws are firmly secured and applied with some glue.**

原廠零件出廠包裝如果是組裝品，請需再確認各螺絲是否鎖緊上膠。

**When tightening a screw to a plastic part, please tighten it firmly, but not over tightened, or they will strip.**

螺絲鎖入塑膠件請務必注意，適當扭力鎖緊即可，而過緊的扭力可能會導致滑牙。

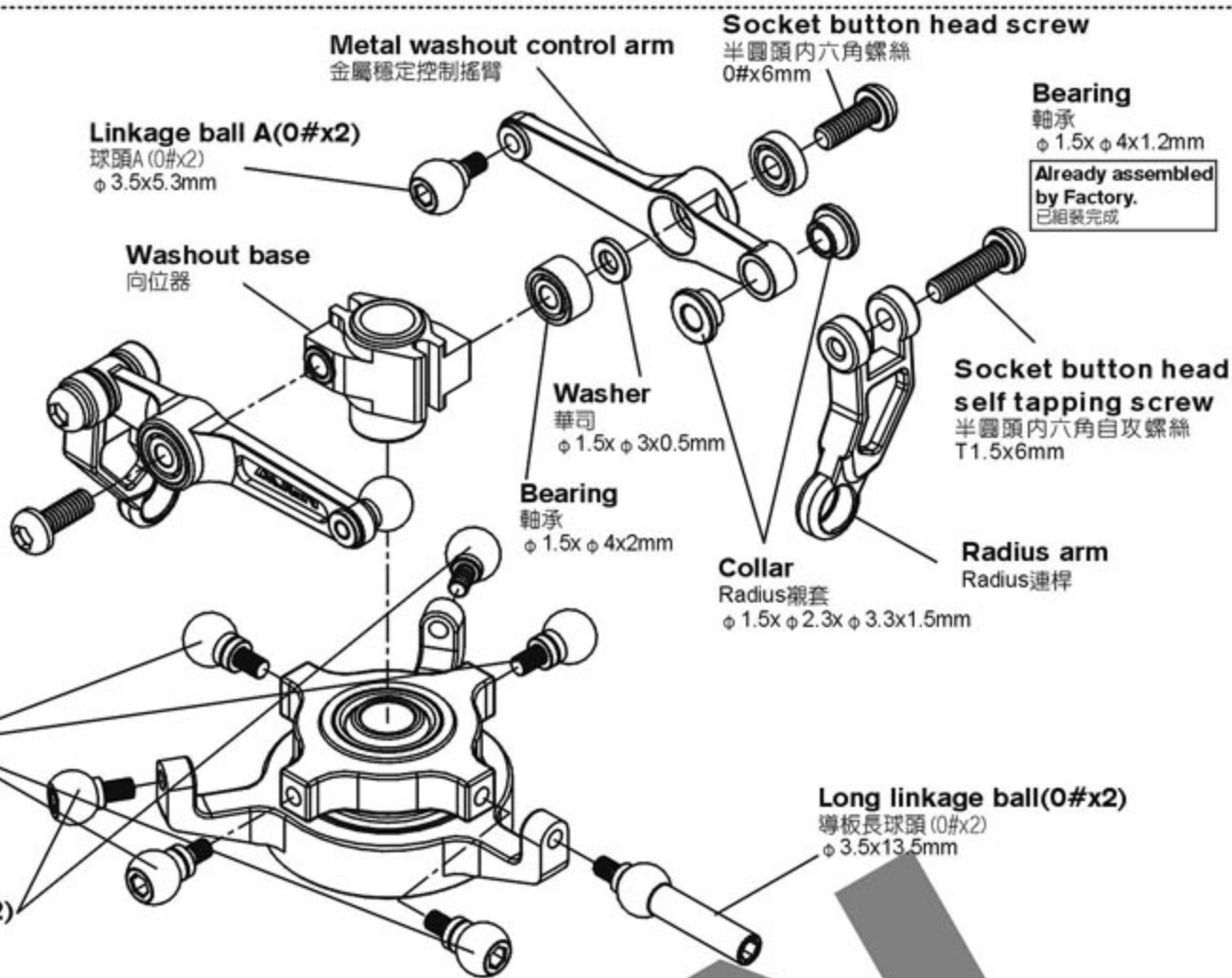

## 250HH11

- Socket button head self tapping screw**  
半圓頭內六角自攻螺絲(T1.5x6mm) x 2
- Washer**  
華司(φ 1.5x φ 3x0.5mm) x 2
- Bearing**  
軸承(φ 1.5x φ 4x1.2mm) x 2
- Bearing**  
軸承(φ 1.5x φ 4x2mm) x 2
- Socket button head screw**  
半圓頭內六角螺絲(0#x6mm) x 3
- Linkage ball A(0#x2)**  
球頭A (0#x2) (φ 3.5x5.3mm) x 2

## 250HH12

- Long linkage ball(0#x2)**  
導板長球頭 (0#x2) (φ 3.5x13.5mm) x 1
- Linkage ball A(0#x2)**  
球頭A (0#x2) (φ 3.5x5.3mm) x 2
- Linkage ball D(0#x2)**  
球頭D (0#x2) (φ 3.5x6mm) x 4

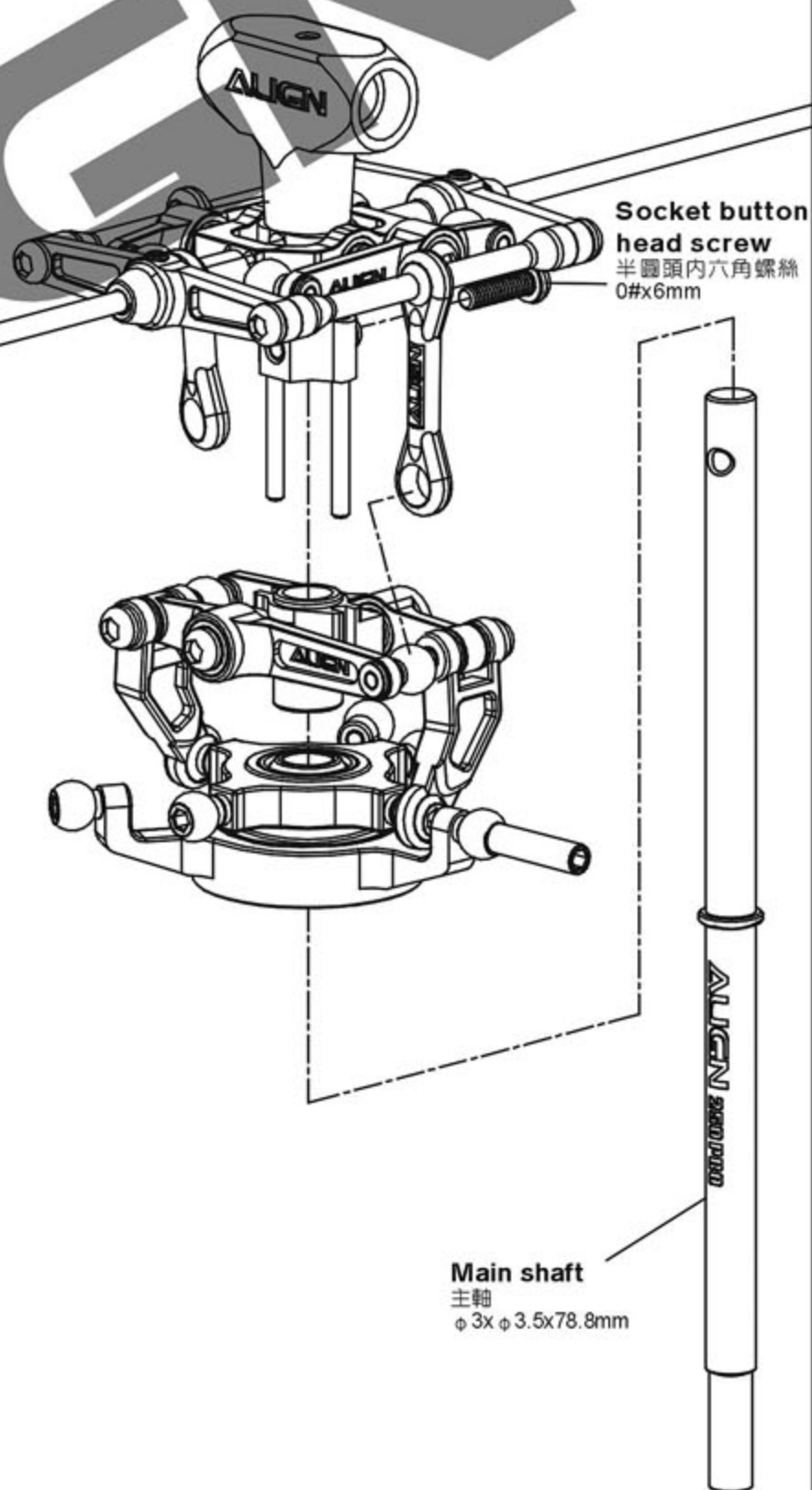

**Apply a little amount of T22 thread lock when fixing a metal part.**  
螺絲鎖附於金屬件請使用適量T22(螺絲膠)

Apply a little amount of T22 thread lock when fixing a metal part.  
螺絲鎖附於金屬件請使用適量T22(螺絲膠)

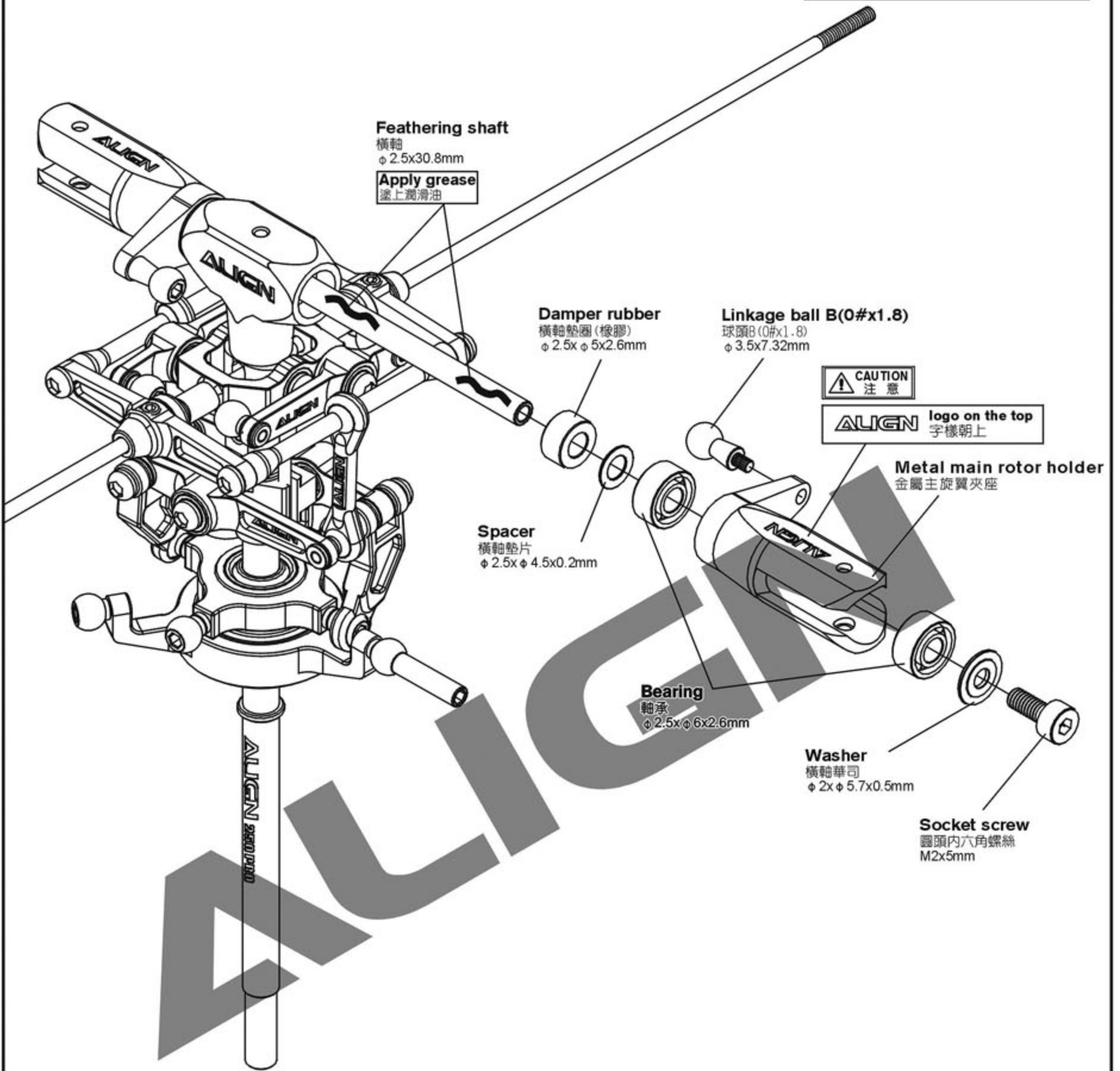

## 250HH11



### Bearing

軸承(φ 2.5x φ 6x2.6mm) x 4



### Socket screw

圓頭內六角螺絲(M2x5mm) x 2



### Linkage ball B(0#x1.8)

球頭B(0#x1.8)(φ 3.5x7.32mm) x 2



### Damper rubber

橫軸墊圈(橡膠)(φ 2.5x φ 5x2.6mm) x 2



### Washer

橫軸華司(φ 2x φ 5.7x0.5mm) x 2



### Spacer

橫軸墊片(φ 2.5x φ 4.5x0.2mm) x 2



注意

For original manufactory package, if the product is already assembled by Factory, please check again if screws are firmly secured and applied with some glue.

原廠零件出廠包裝如果是組裝品，請需再確認各螺絲是否鎖緊上膠。



Apply a little amount of T22 thread lock when fixing a metal part.  
 螺絲鎖附於金屬件請使用適量T22(螺絲膠)

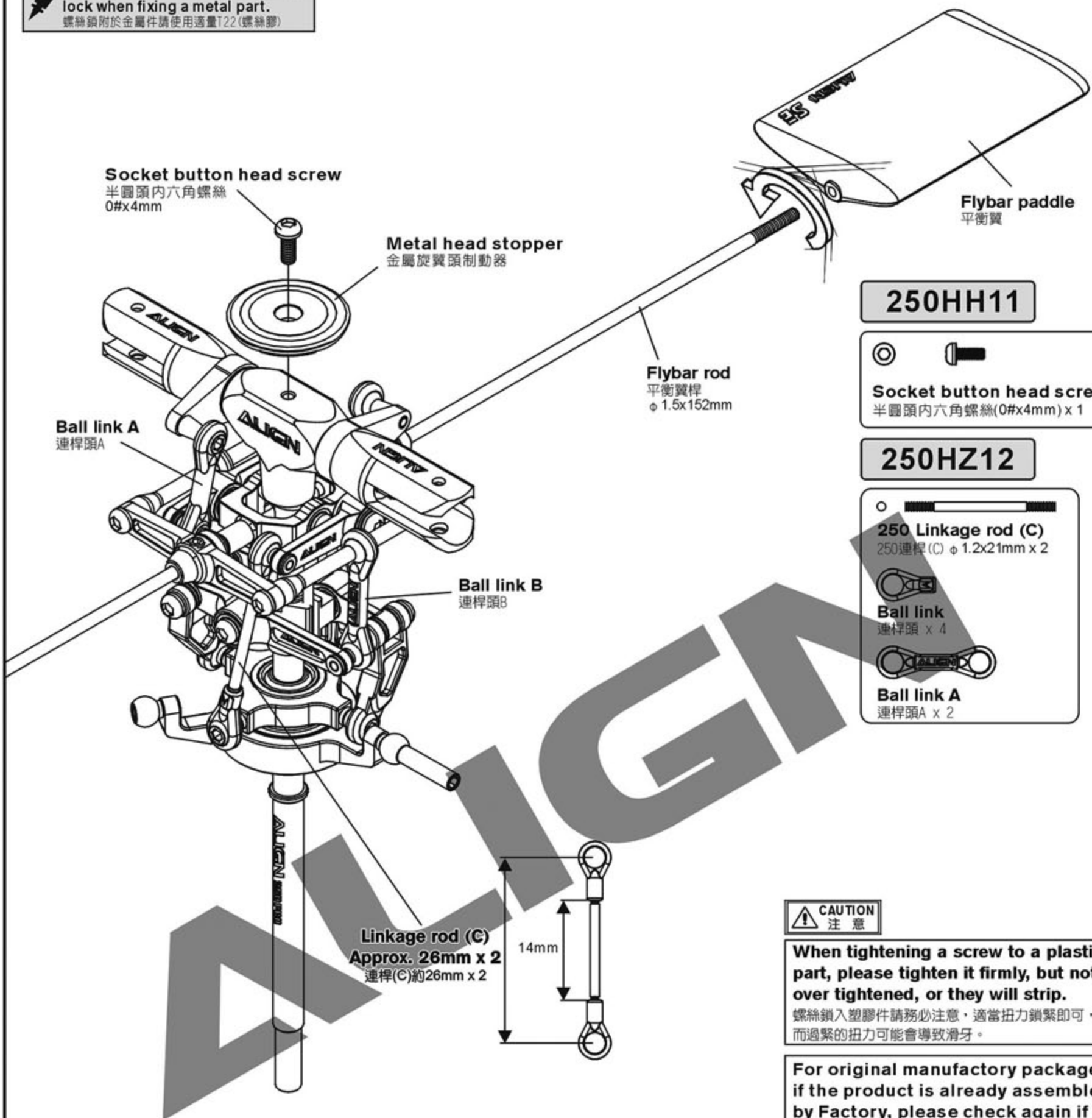

**250HH11**

Socket button head screw  
 半圓頭內六角螺絲(0#x4mm) x 1

**250HZ12**

250 Linkage rod (C)  
 250連桿(C) φ 1.2x21mm x 2

Ball link  
 連桿頭 x 4

Ball link A  
 連桿頭A x 2

**CAUTION**  
 注意

**When tightening a screw to a plastic part, please tighten it firmly, but not over tightened, or they will strip.**  
 螺絲鎖入塑膠件請務必注意，適當扭力鎖緊即可，而過緊的扭力可能會導致滑牙。

**For original manufactory package, if the product is already assembled by Factory, please check again if screws are firmly secured and applied with some glue.**  
 原廠零件出廠包裝如果是組裝品，請需再確認各螺絲是否鎖緊上膠。

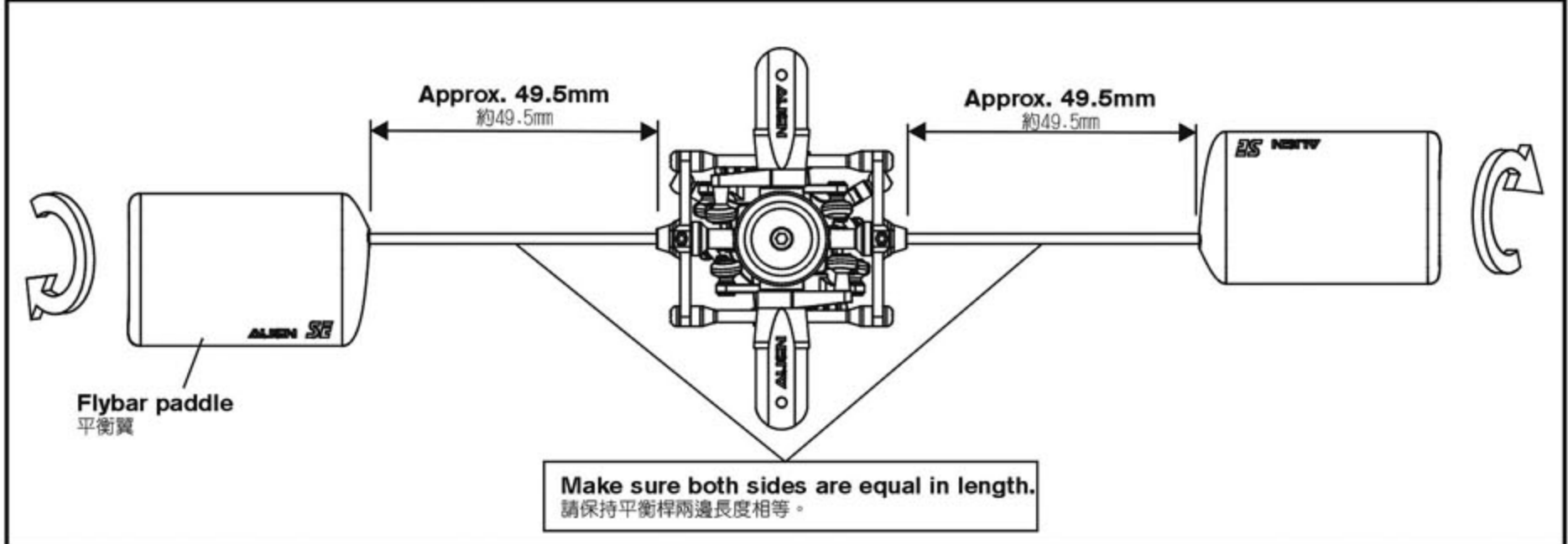

## 250HZ12

**Socket button head self tapping screw**  
半圓頭內六角自攻螺絲(T2x6mm) x 6

**Linkage ball B(0#x1.8)**  
球頭B(0#x1.8) (φ 3.5x7.32mm) x 2

**Linkage ball A(0#x2)**  
球頭A(0#x2) (φ 3.5x5.3mm) x 1

**Carbon fiber upper frame**  
碳纖上側板(左)  
110.49x42.6x1.2mm

**Socket button head self tapping screw**  
半圓頭內六角自攻螺絲  
T2x6mm

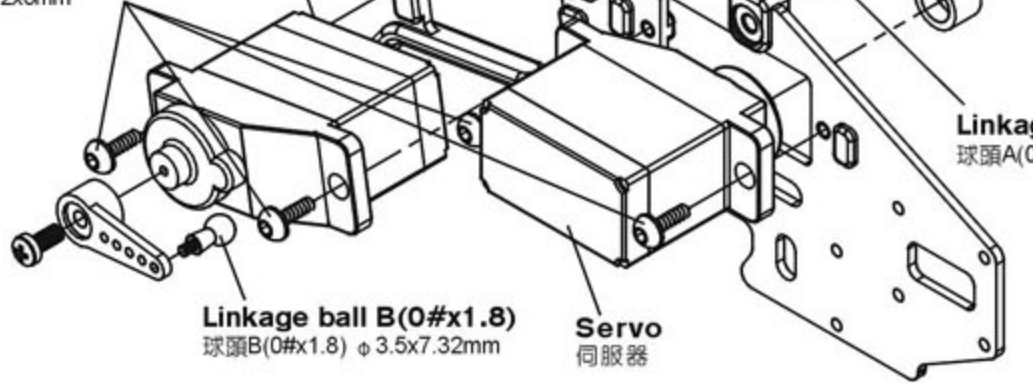

**Linkage ball B(0#x1.8)**  
球頭B(0#x1.8) φ 3.5x7.32mm

**Servo**  
伺服器

**Linkage ball A(0#x2)**  
球頭A(0#x2) φ 3.5x5.3mm

**Carbon fiber upper frame**  
碳纖上側板(右)  
110.49x42.6x1.2mm

Apply a little amount of T22 thread lock when fixing a metal part.  
螺絲鎖於金屬件請使用適量T22(螺絲膠)

## 250HB4

**Socket button head self tapping screw**  
半圓頭內六角自攻螺絲(T1.5x3mm) x 12

**Socket button head screw**  
半圓頭內六角螺絲(0#x3mm) x 14

**Battery mount**  
電池座

**Frame mounting bolt**  
機身鋁固定柱

**Socket button head screw**  
半圓頭內六角螺絲  
0#x3mm

**Bearing**  
軸承  
φ 3.5x φ 7x2.5mm

**Socket button head self tapping screw**  
半圓頭內六角自攻螺絲  
T1.5x3mm

**Carbon fiber upper frame**  
碳纖上側板  
110.49x42.6x1.2mm

**Socket button head screw**  
半圓頭內六角螺絲  
0#x3mm

**Main shaft block**  
主軸固定座

**Metal tail drive gear assembly**  
金屬尾傳動輪組

**Tail boom mount (Right)**  
尾管固定座(右)

**Tail drive gear mount(L)**  
尾傳動輪座(左)

**Tail drive gear mount(R)**  
尾傳動輪座(右)

**Drive belt**  
皮帶

**Socket button head self tapping screw**  
半圓頭內六角自攻螺絲  
T1.5x3mm

**Socket button head screw**  
半圓頭內六角螺絲  
0#x3mm

**Tail boom mount (Left)**  
尾管固定座(左)

**Plastic hexagonal bolt**  
機身六角鋁柱  
2.2x14mm

### Main frame assembly point:

First do not fully tighten the screws of main frames. Put the main shaft through the two bearings and check if the movements (up/down) are smooth. The bottom bracket must be firmly touched the level table top (glass surface); please keep the smooth movements on main shaft and level bottom bracket, then slowly tighten the screws. A correct assembly can help for the power and flight performance.

機身側板組立重點:

側板螺絲先不完全鎖緊，放入主軸貫穿二顆軸承確認上下移動必須滑順，主體底板必須與水平桌面（玻璃平面）踏實緊貼；請保持主軸滑順與底板平行桌面後慢慢鎖緊螺絲。正確側板的組裝對動力與飛行性能有顯著幫助。

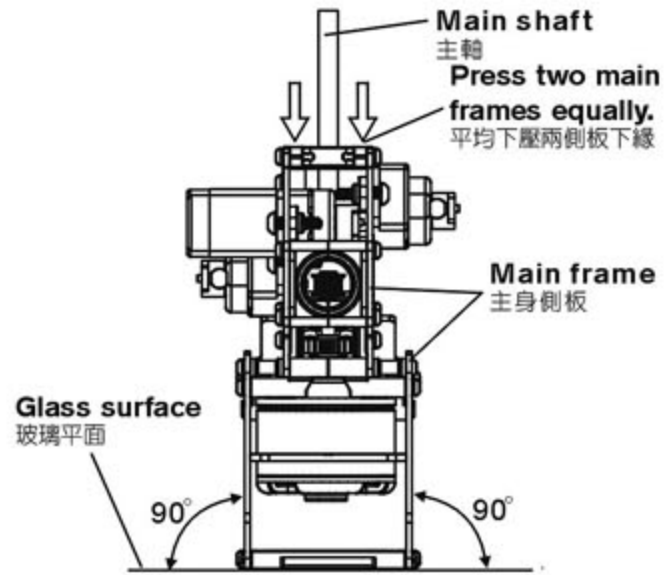

### 250HB5A

Socket button head self tapping screw  
半圓頭內六角自攻螺絲(T1.5x4mm) x 2

Socket button head screw  
半圓頭內六角螺絲(M2.5x5mm) x 2

Socket button head screw  
半圓頭內六角螺絲(0#x10mm) x 2

Socket button head self tapping screw  
半圓頭內六角自攻螺絲(T1.5x3mm) x 2

### 250HB4

Socket button head self tapping screw  
半圓頭內六角自攻螺絲(T1.5x3mm) x 4

Socket button head screw  
半圓頭內六角螺絲(0#x4mm) x 6

### 250HZ12

Socket button head self tapping screw  
半圓頭內六角自攻螺絲(T2x8mm) x 2

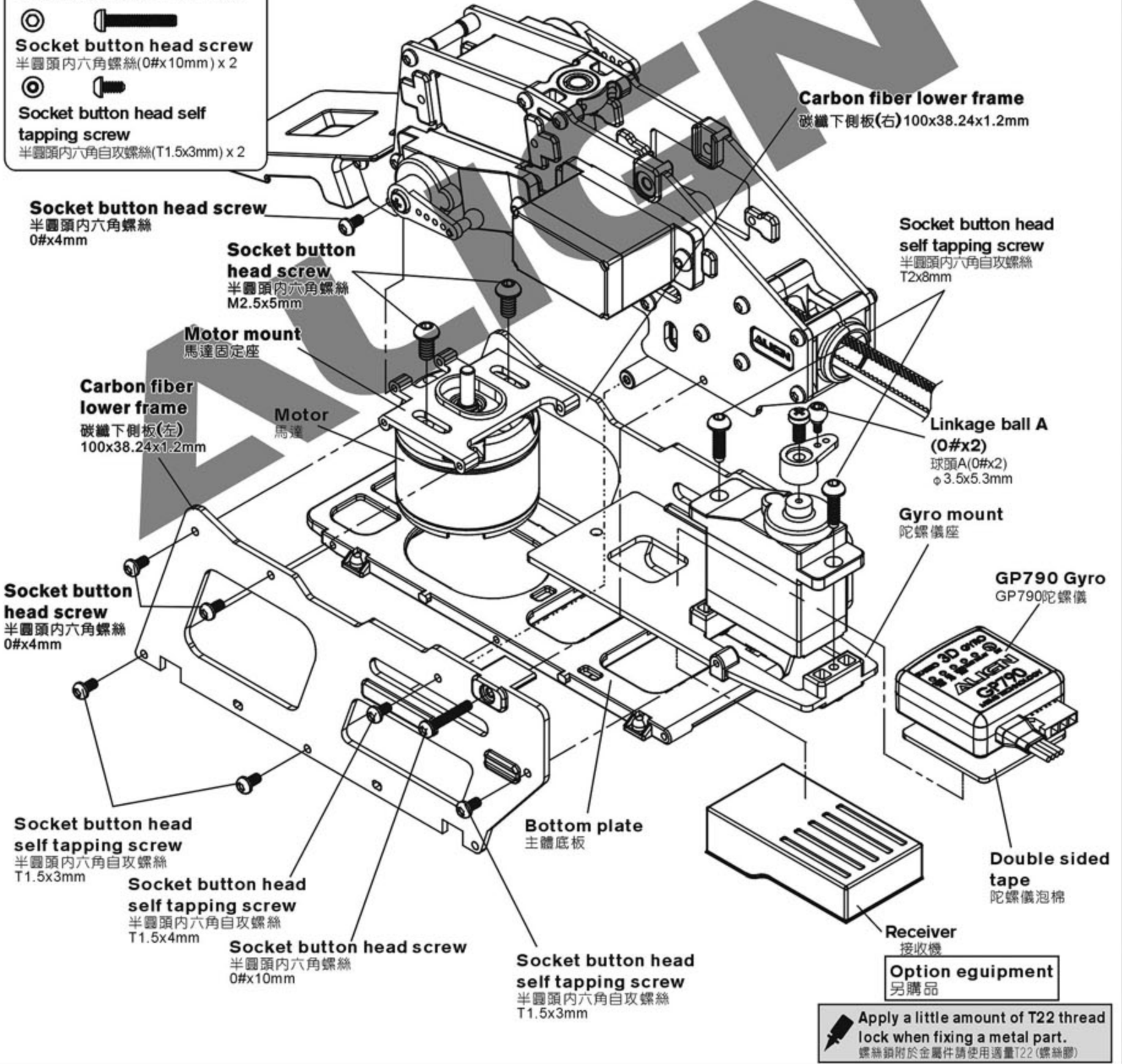

## 250HG2A



  
**Socket button head self tapping screw**  
 半露頭內六角自攻螺絲(T1.5x6mm) x 4

  
**M2 Set screw**  
 M2止洩螺絲(M2x2mm) x 4

### DS410 Digital Servo:

1. Stall torque/輸出扭力: 1.8kg.cm(4.8V)  
2.2kg.cm(6.0V)
2. Motion speed/動作速度: 0.13sec/60° (4.8V)  
0.09sec/60° (6.0V)
3. Dimension/尺寸: 22.8 x 12 x 25.4mm
4. Weight/重量: 12.7g

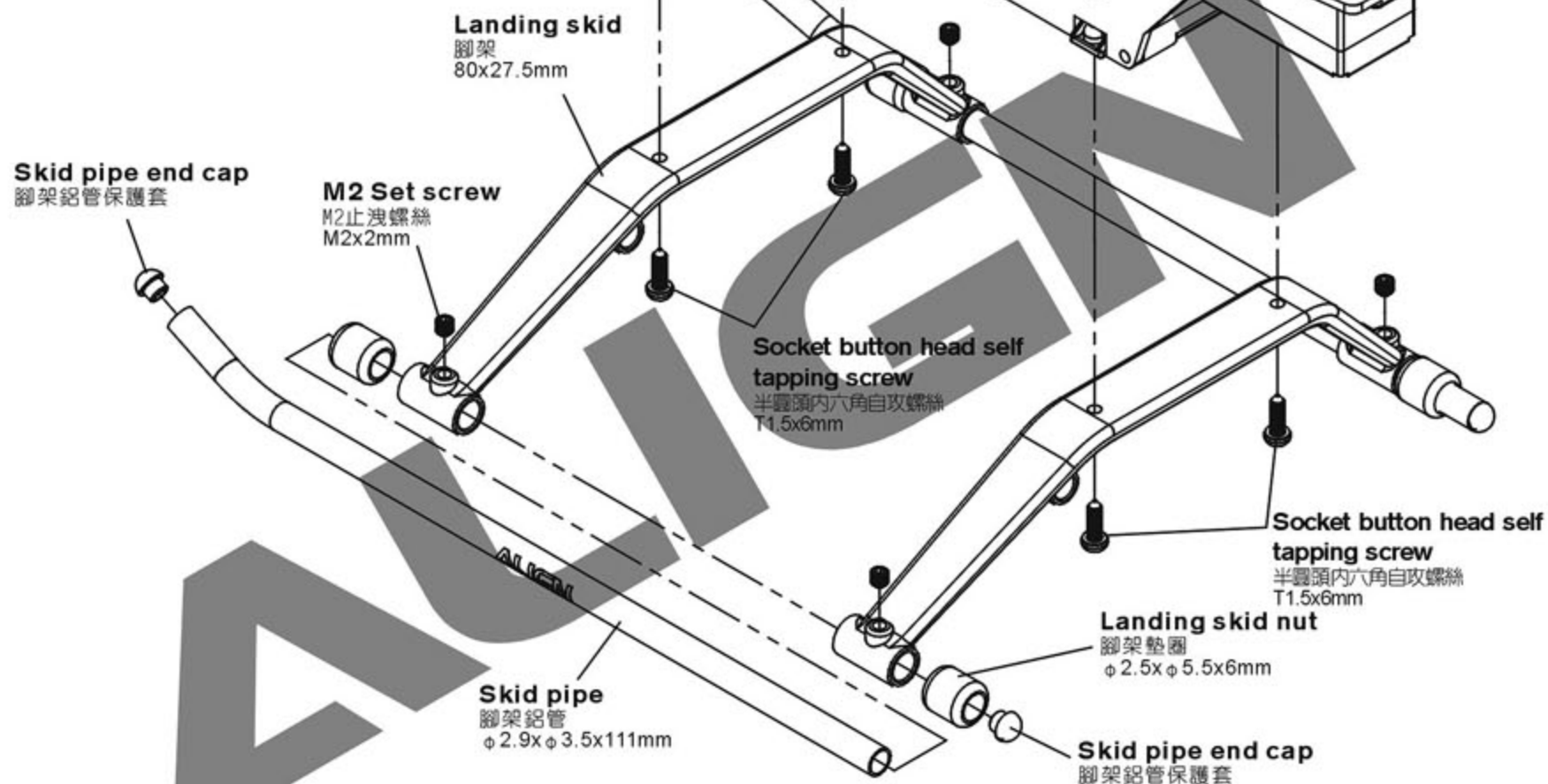
 Apply a little amount of T22 thread lock when fixing a metal part.  
 螺絲鎖附於金屬件請使用適量T22(螺絲膠)



## 250HB2

  
**Bearing**  
 軸承(φ 3x φ 7x2mm) x 1

  
**Countersunk philips self tapping screw**  
 皿頭十字自攻螺絲(T1.5x4mm) x 4

**New main drive gear**  
 新型主齒盤  
 120T

**Words face down**  
 字體請朝下

**Main gear case**  
 主齒中心座

**Countersunk philips self tapping screw**  
 皿頭十字自攻螺絲  
 T1.5x4mm

**One-way bearing**  
 單向軸承  
 φ 3x φ 6.5x6mm

**Already assembled by factory, please note to check again.**  
 已組裝完成，請務必自行再確認。

**Bearing**  
 軸承  
 φ 3x φ 7x2mm

## 250HH11

**Socket screw**  
圓頭內六角螺絲(M2x8mm) x 2

## 250HZ4

**M2 Set screw**  
M2止洩螺絲(M2x10mm) x 2

## 250HH12

**Socket button head screw**  
半圓頭內六角螺絲(0#x4mm) x 1

**Washer**  
華司(φ 1.5xφ 5x0.3mm) x 1

**Spacer**  
單向墊片  
φ 3xφ 4.8x0.5mm

**New main drive gear**  
新型主齒輪組120T

**Washer**  
華司  
φ 1.5xφ 5x0.3mm

**Socket button head screw**  
半圓頭內六角螺絲  
0#x4mm

**Socket screw**  
圓頭內六角螺絲  
M2x8mm

Apply a little amount of T22 thread lock when fixing a metal part.  
螺絲鎖附於金屬件請使用適量T22(螺絲膠)

**Linkage rod (E)**  
Approx. 26.5mm x 1  
連桿(E)約26.5mm x 1

**Linkage rod (D)**  
Approx. 38.5mm x 1  
連桿(D)約38.5mm x 1

**Linkage rod (F)**  
Approx. 28mm x 1  
連桿(F)約28mm x 1

**Canopy mounting bolt**  
機頭罩固定柱

**M2 Set screw**  
M2止洩螺絲M2x10mm

**Anti rotation bracket**  
金屬十字盤導板

## 250HZ12

**250 Linkage rod (C)**  
250連桿(C) φ 1.2x21mm x 2

**250 Linkage rod (D)**  
250連桿(D) φ 1.2x32.5mm x 1

**Ball link**  
連桿頭 x 6

While fastening the screw, please do not over-tighten to avoid the reduce of main blade's auto rotate ability. Follow by suitable use of T22 thread lock compound to secure in place.

注意螺絲鎖附至定位時，請注意勿過度鎖緊，避免熄火時主旋翼自旋能力的降低，並使用適量T22(螺絲膠)固定。

**CAUTION**  
注意

Please wait for at least 30 mins after gluing R48 on the motor pinion gear. You may start operating after the glue dried.

馬達主齒上R48後請務必靜置30分鐘以上，待膠乾透後方可運轉。

**Gear surface should be flush with tip of motor shaft.**  
齒輪面與馬達心軸平齊。

R48

**Motor Pinion Gear 15T**  
15T馬達主齒

**Motor**  
馬達  
3400KV

Set the motor pinion gear to main drive gear mesh to approximately 0.1mm to avoid excess power consumption or motor burnt due to overload.

馬達前後可移動以保持兩齒輪咬合處約有0.1mm間隙，過緊齒咬合將造成動力損失或馬達高阻力的過載，嚴重可能造成馬達燒毀。

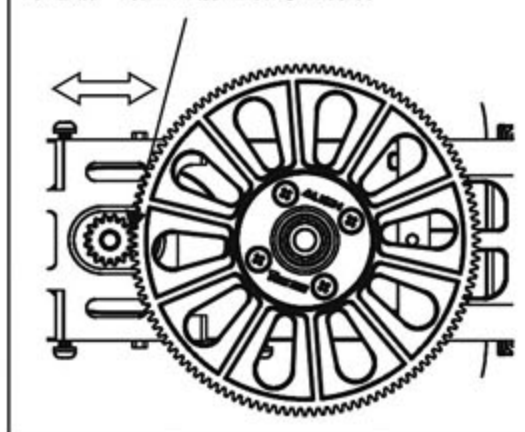
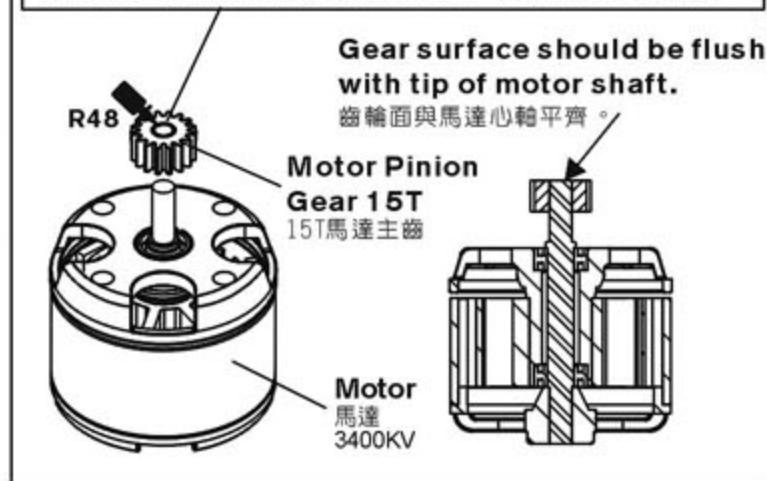
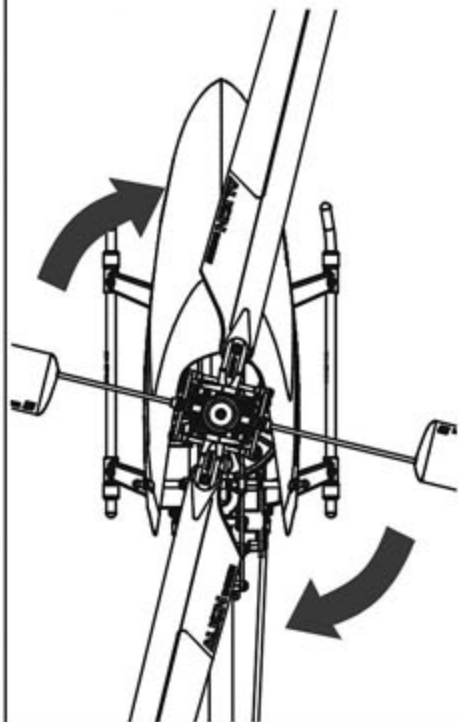

Apply a little amount of T22 thread lock when fixing a metal part.  
螺絲鎖附於金屬件請使用適量T22(螺絲膠)

250HT7



Ball link  
連桿頭 x 2



**CAUTION**  
注意

Aim the opening of tail boom at the convex of the case and insert.  
瞄準尾管上的凹槽和尾座凸出，並插入。

Please insert the opening of tail boom into the convex.  
尾管缺口方向裝入時，請導入尾管座卡榫內。

Tail boom  
尾管  
φ7.9xφ8.5x241.7mm

250HT7

Tail control guide  
尾控制桿固定環

Bill link  
連桿頭

Rudder control screw  
尾舵控制連桿 φ 1.2x230mm



**CAUTION**  
注意

Drive belt illustration 尾傳動皮帶裝配圖示

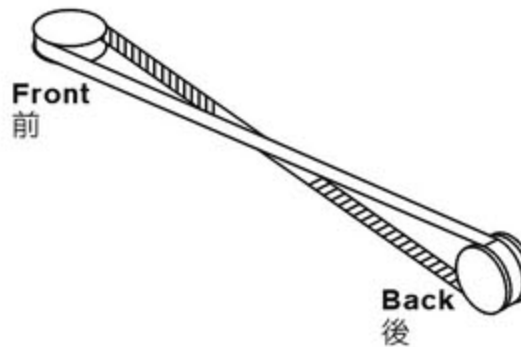

1. Check to rotate the belt 90° degrees when assembling.
2. Belt tension: Recommend to lightly tighten the drive belt after assembling tail boom to avoid vibration, belt friction and rotation slip.

1. 組裝時確認皮帶順轉90°
2. 皮帶緊度：建議尾管組裝後皮帶請稍微拉緊，避免震動皮帶摩擦或轉動打滑。

Approx. 120mm  
約120mm

# 250HT6

Apply a little amount of T22 thread lock when fixing a metal part.  
螺絲鎖附於金屬件請使用適量T22(螺絲膠)

- Socket button head screw**  
半圓頭內六角螺絲(0#x3mm) x 4
- Socket button head screw**  
半圓頭內六角螺絲(0#x6mm) x 1
- Bearing**  
軸承(φ 2x φ 5x2.5mm) x 2

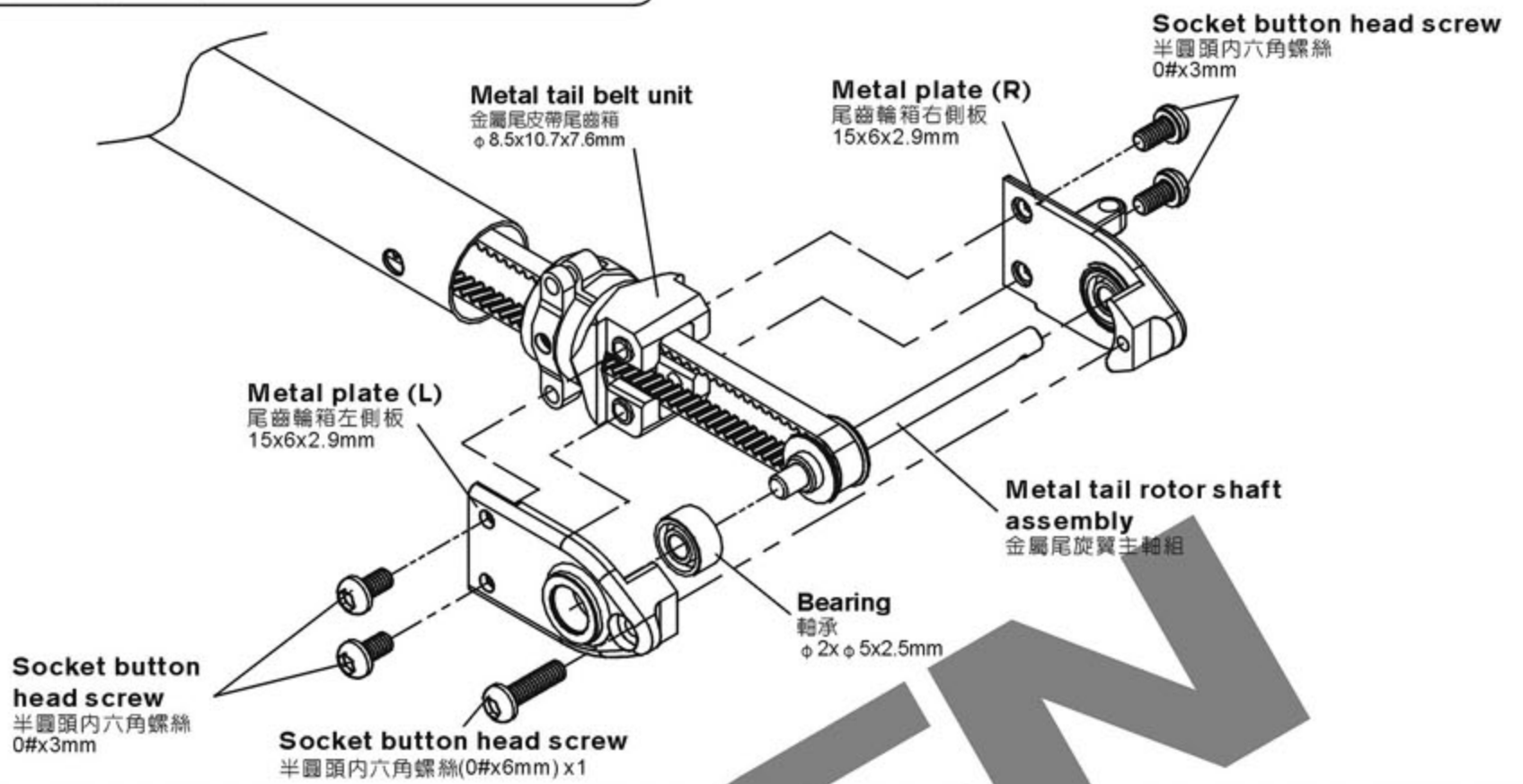

# 250HT6

- Socket button head screw**  
半圓頭內六角螺絲(0#x4mm) x 2
- Socket button head screw**  
半圓頭內六角螺絲(0#x5mm) x 2
- Socket button head screw**  
半圓頭內六角螺絲(0#x5mm) x 2
- Bearing**  
軸承(φ 1.5x φ 4x2mm) x 2
- Bearing**  
軸承(φ 3x φ 6x2.5mm) x 2
- Washer**  
尾夾座華司(φ 1.5x φ 3.8x0.7mm) x 2
- Washer**  
華司(φ 3x φ 4.8x0.6mm) x 1

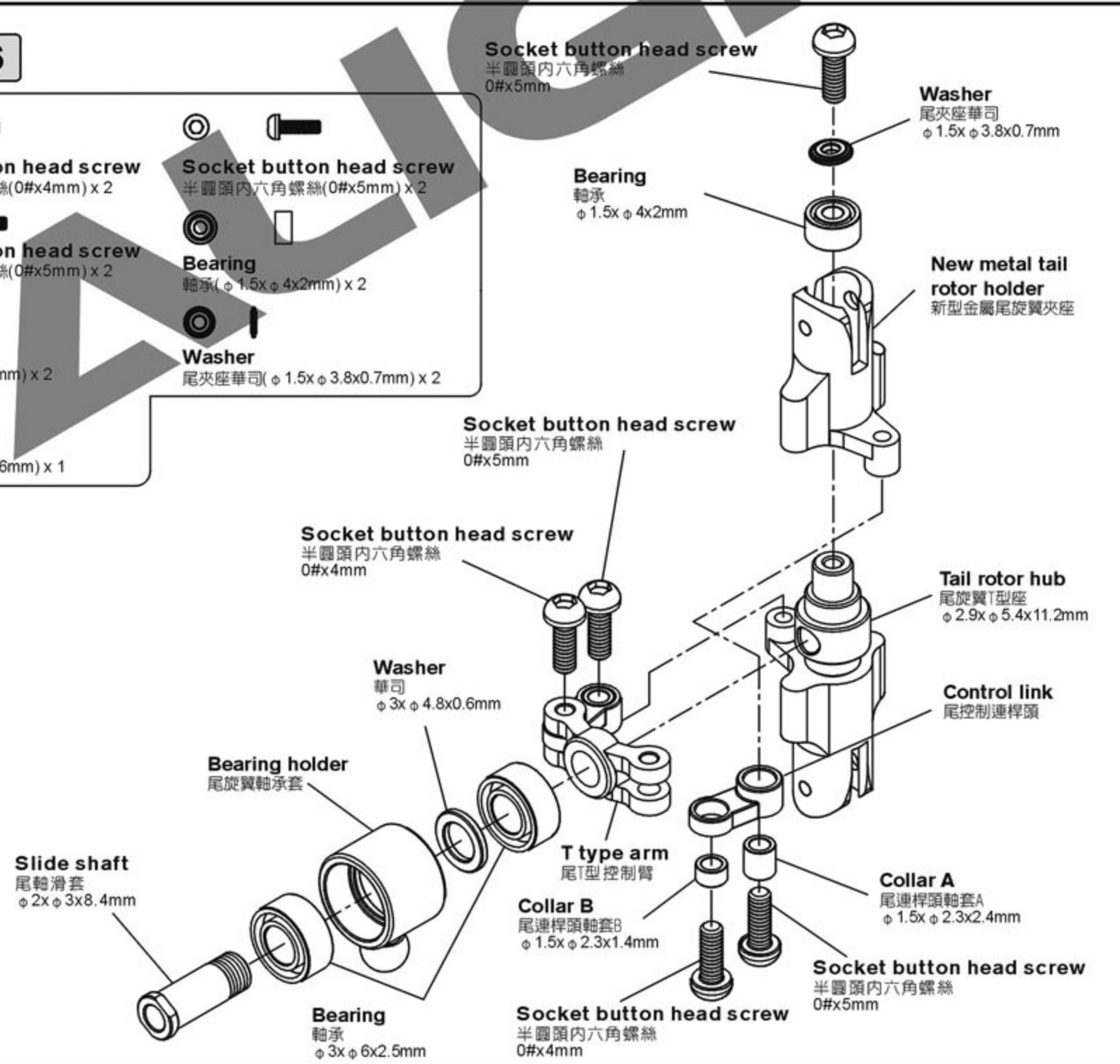

# 250HT6



**Socket button head screw**  
半圓頭內六角螺絲(0#x6mm) x 2



**Socket button head screw**  
半圓頭內六角螺絲(0#x8mm) x 1



**M2 Set screw**  
M2止洩螺絲(M2x2mm) x 1



**Linkage ball A(0#x2)**  
球頭A(0#x2) (φ 3.5x5.3mm) x 1



**Washer**  
華司(φ 1.5xφ 3x0.5mm) x 1

Apply a little amount of T22 thread lock when fixing a metal part.  
螺絲鎖附於金屬件請使用適量T22(螺絲膠)



**When tightening a screw to a plastic part, please tighten it firmly, but not over tightened, or they will strip.**  
螺絲鎖入塑膠件請務必注意，適當扭力鎖緊即可，而過緊的扭力可能會導致滑牙。

**For original manufactory package, if the product is already assembled by Factory, please check again if screws are firmly secured and applied with some glue.**  
原廠零件出廠包裝如果是組裝品，請需再確認各螺絲是否鎖緊上膠。



**Aim tail rotor hub at the concave of tail rotor shaft and fix it, please apply a little glue on the set screw.**  
尾旋翼T型座瞄準尾橫軸的凹刻並鎖上，請確認止洩螺絲上膠。

**Already assembled by factory, please note to check again.**  
已組裝完成，請務必自行再確認。

**Tail pitch assembly**  
尾旋翼控制組

**M2 Set screw**  
M2止洩螺絲  
M2x2mm

**Socket button head screw**  
半圓頭內六角螺絲  
0#x6mm

**Tail rotor control arm**  
尾旋翼控制臂

**Collar**  
尾旋翼控制臂軸套  
φ 1.5xφ 2.5x5mm

**Washer**  
華司  
φ 1.5xφ 3x0.5mm

**Linkage ball A(0#x2)**  
球頭A(0#x2)  
φ 3.5x5.3mm

**Socket button head screw**  
半圓頭內六角螺絲  
0#x8mm



**When tightening a linkage ball to a plastic part, please note to use a little CA glue and tighten it firmly, but not over tightened, or they will strip.**  
球頭鎖入塑膠件請務必注意，使用少量CA膠並適當扭力鎖緊即可，而過緊的扭力可能會導致滑牙。

**Care must be taken during assembly to ensure tail grips operate smoothly without binding. Any slight binding may affect tail action during flight.**  
組裝時，確保尾夾座滑順，些微干涉將可能導致飛行時尾動作不順暢。

**Tail pitch assembly**  
尾旋翼控制組

**Tail pitch bell crank must be parallel to tail output shaft to ensure sufficient pitch travel range.**  
尾T型座與尾橫軸平齊以保持行程量足夠。



Apply a little amount of T22 thread lock when fixing a metal part.  
螺絲鎖附於金屬件請使用適量T22(螺絲膠)

### 250HT6



**Socket button head screw**

半圓頭內六角螺絲(0#x5mm) x 1



**Socket button head screw**

半圓頭內六角螺絲(0#x8mm) x 1

### 250HB4



**Socket button head self tapping screw**

半圓頭內六角自攻螺絲(T1.5x6mm) x 2

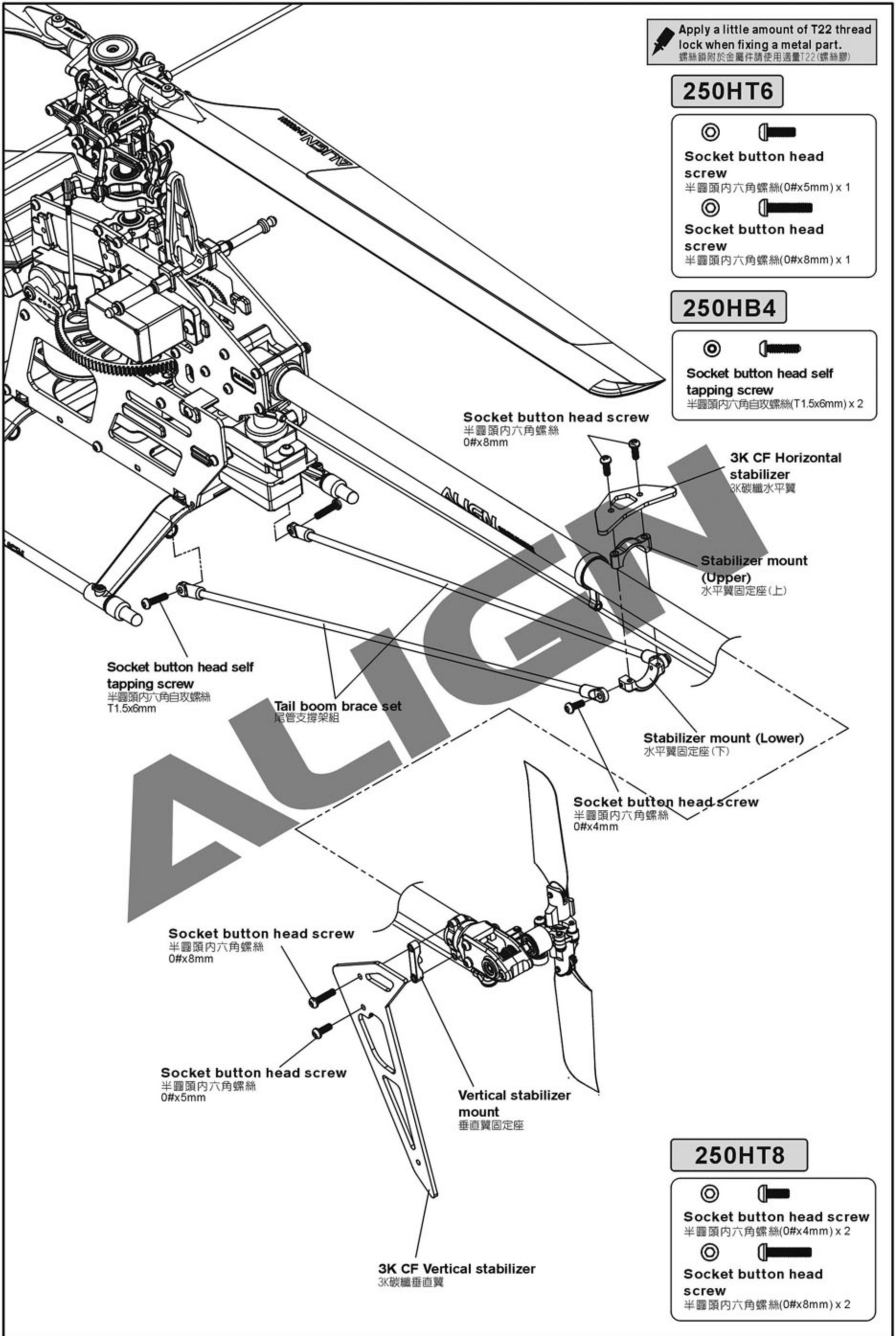

**Socket button head screw**  
半圓頭內六角螺絲  
0#x8mm

**3K CF Horizontal stabilizer**  
3K碳纖水平翼

**Stabilizer mount (Upper)**  
水平翼固定座(上)

**Socket button head self tapping screw**  
半圓頭內六角自攻螺絲  
T1.5x6mm

**Tail boom brace set**  
尾管支撐架組

**Stabilizer mount (Lower)**  
水平翼固定座(下)

**Socket button head screw**  
半圓頭內六角螺絲  
0#x4mm

**Socket button head screw**  
半圓頭內六角螺絲  
0#x8mm

**Socket button head screw**  
半圓頭內六角螺絲  
0#x5mm

**Vertical stabilizer mount**  
垂直翼固定座

**3K CF Vertical stabilizer**  
3K碳纖垂直翼

### 250HT8



**Socket button head screw**

半圓頭內六角螺絲(0#x4mm) x 2



**Socket button head screw**

半圓頭內六角螺絲(0#x8mm) x 2

## 7. GYRO INSTALLATION SUGGESTION 陀螺儀安裝建議位置

ALIGN

Use attached Hoop and Loop Tape, tape the Hoop side (hooked) on the battery mounting plate and the Loop side (fuzzy) on the battery to fix the battery in order to prevent any slip.

以附贈的魔術沾膠帶，將公端的魔術沾(勾狀)黏貼於電池座上，母端的魔術沾(纖毛狀)黏貼於電池上，可有效固定電池避免滑動。

Hook and Loop Tape (fuzzy)  
魔術沾母端

Hook and Loop Tape (hooked)  
魔術沾公端

ESC installation location  
ESC放置位

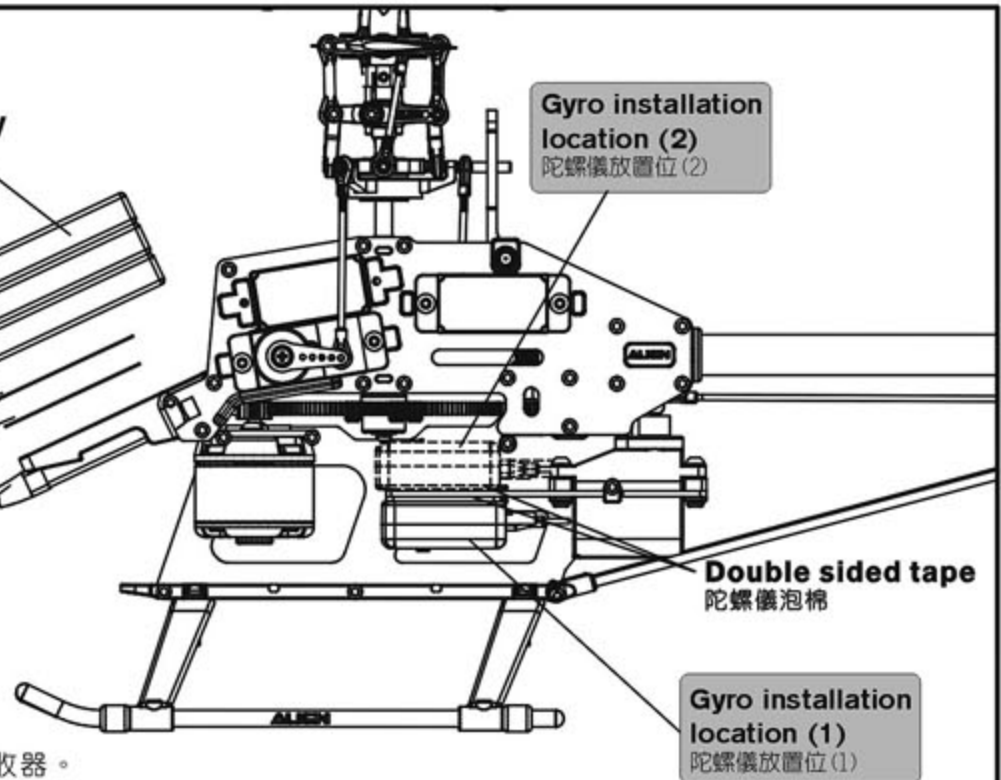

**NOTE: When installing the speed controller, please keep a distance at least 1 cm from the receiver to avoid any interference.**

注意：安裝ESC時請與接收器保持至少1cm以上的距離，避免干擾接收器。

## 8. CANOPY ASSEMBLY 機頭罩安裝

ALIGN

250HC3

Canopy  
機頭罩

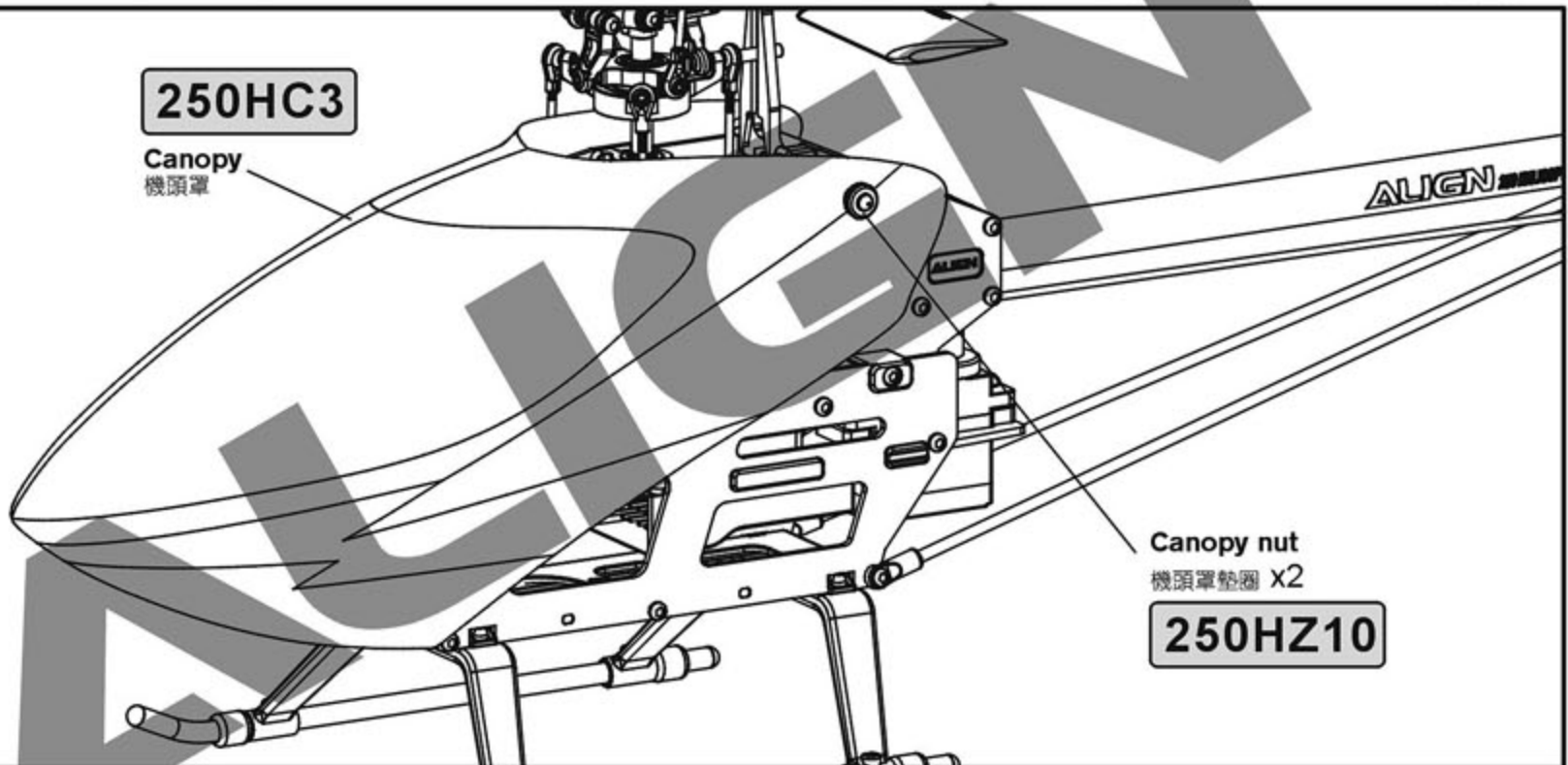

Canopy nut  
機頭罩墊圈 x2

250HZ10

## 9. DIAL PITCH GAUGE PAD INSTRUCTION 可調式螺距規墊塊使用說明

ALIGN

Dial Pitch Gauge Pad  
可調式螺距規墊塊

ALIGN Dial Pitch Gauge

旋轉式螺距規  
料號：K10391A-1

Optional  
選購

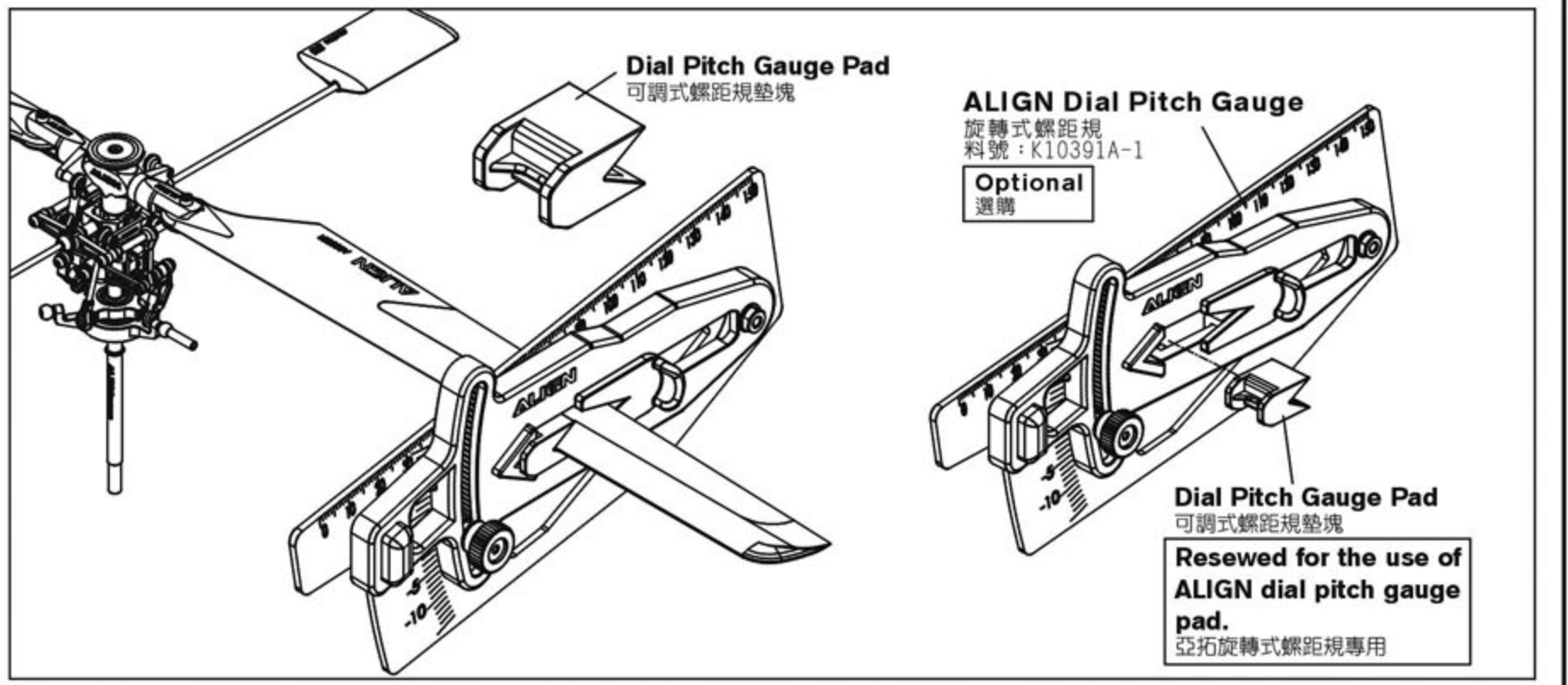

Dial Pitch Gauge Pad  
可調式螺距規墊塊

Reserved for the use of  
ALIGN dial pitch gauge  
pad.  
亞拓旋轉式螺距規專用

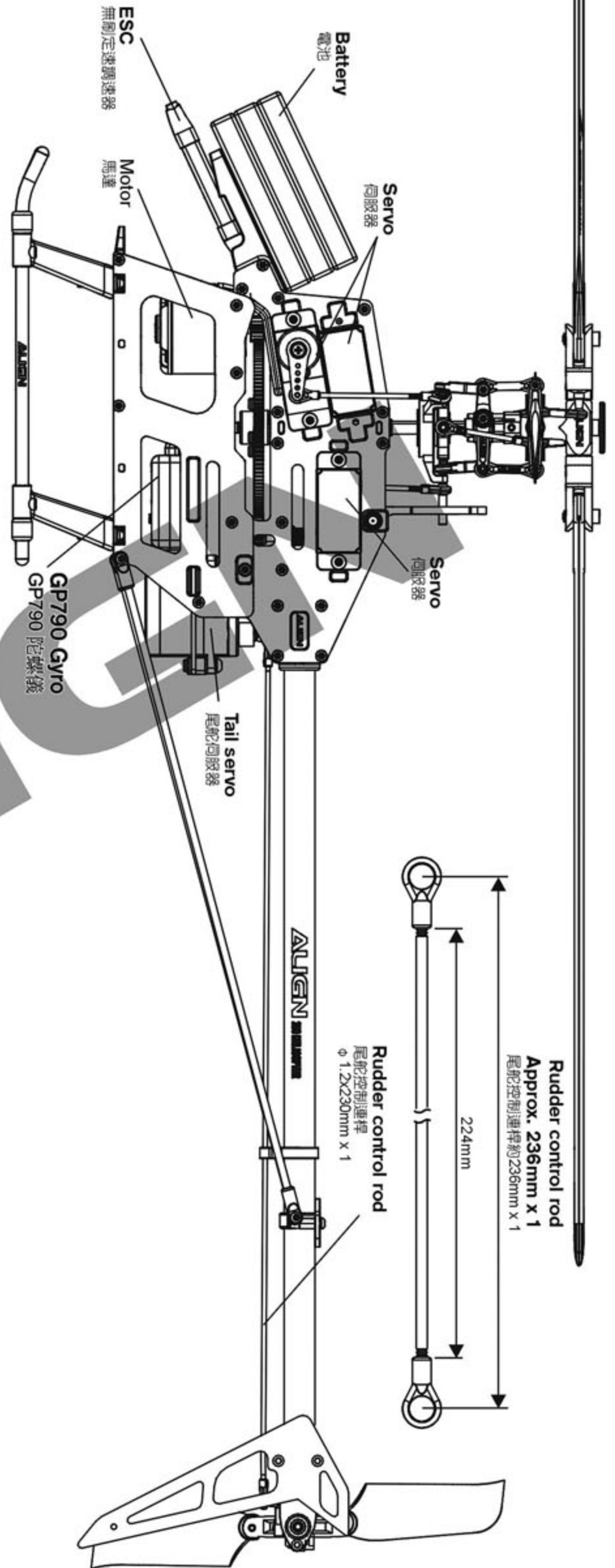

**HITEC、FUTABA 6CH receiver wiring**  
HITEC.FUTABA 6CH接收器接線示意圖

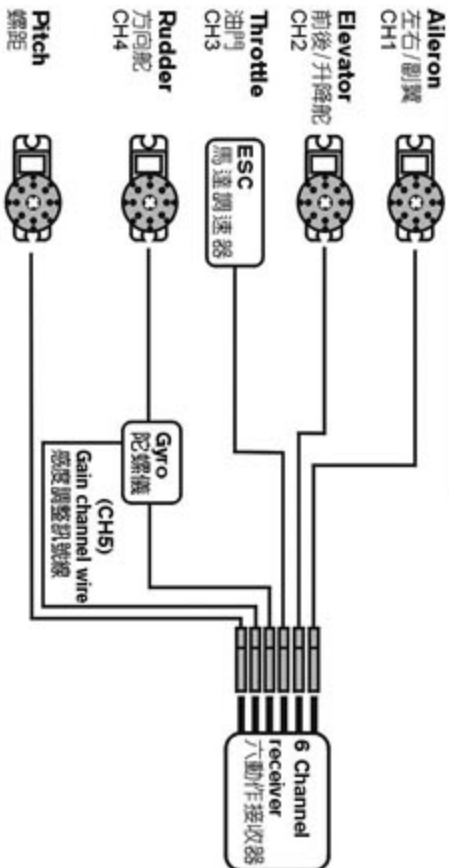

6-Channel Receiver is adequate for the requirements of T-REX helicopter. You will need the following channels at a minimum: Throttle, Rudder, Elevator, Aileron, and especially Pitch(CH6) and Gyro(CH5) controls. 六動作的接收器已足夠應對T-REX遙控直昇機的頻道需求，除了油門、方向舵、升降舵、副翼等基本動作外，亦可以對應具備敏感度調整訊號線的陀螺儀(CH5)與螺距(CH6)。

**JR 7CH receiver wiring**  
JR 7CH接收器接線示意圖

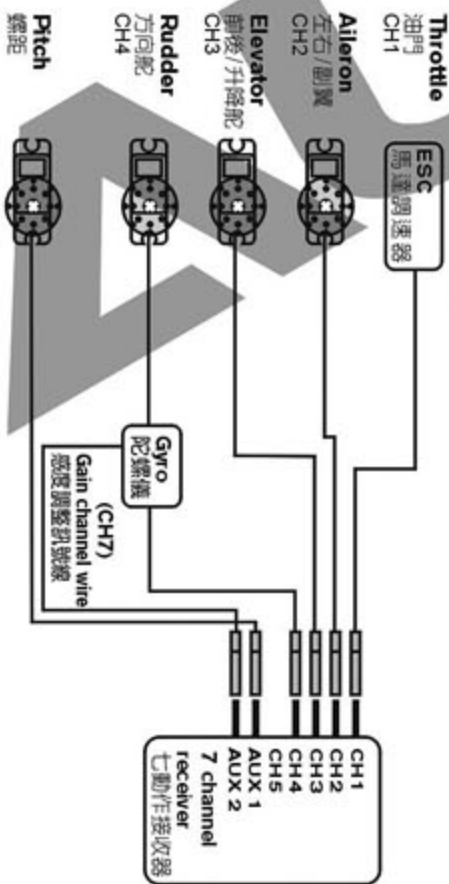

7-Channel Receiver is adequate for the requirements of T-REX helicopter. You will need the following channels at a minimum: Throttle, Rudder, Elevator, Aileron, and especially Pitch(AUX 1) and Gyro(AUX 2) controls. 七動作的接收器已足夠應對T-REX遙控直昇機的頻道需求，除了油門、方向舵、升降舵、副翼等基本動作外，亦可以對應具備敏感度調整訊號線的陀螺儀(AUX 2)與螺距(AUX 1)。

To set this option is to turn on the transmitter and connect to the helicopter power. **Note: For the safety, please do not connect ESC to the brushless motor before the setting in order to prevent any accident caused by the motor running during the setting.**  
 此項設定只要開啓發射器，接上直昇機電源即可進行操作。注意：為了安全起見，設定前請先不要將無刷調速器與無刷馬達的三條線接上，以免調整時啓動馬達而發生危險。

### JR Transmitter/Servo JR遙控器對應伺服器關係

Pitch:CH6  
螺距:CH6

Aileron:CH2  
副翼:CH2

Aileron:CH2  
副翼:CH2

Pitch:CH6  
螺距:CH6

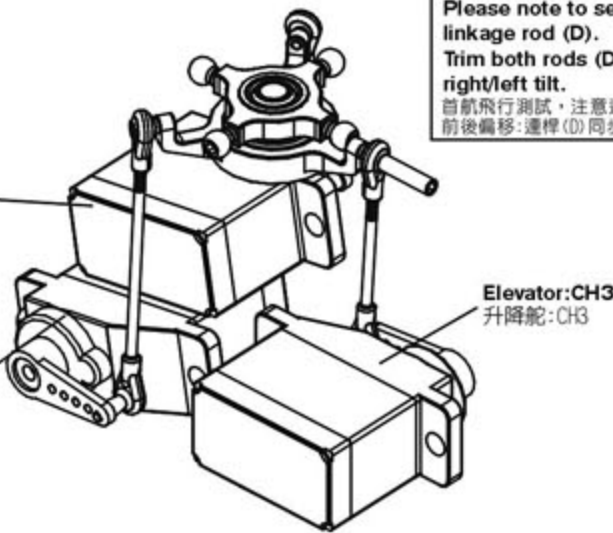

Please note to set the subtrim neutral for the first trial flight. If the helicopter wags, please trim linkage rod (D).  
 Trim both rods (D) simultaneously to adjust for forward/backward tilt. Trim rod (D) separately for right/left tilt.  
 首次飛行測試，注意遙控器微調均設定中立點，若發現飛行時，機身前後左右偏移，請先調整連桿(D)前後偏移。連桿(D)同步調整；左右偏移。連桿(D)單獨調整為標準。

Positions of CH2、CH6 are exchangeable, After assembling as photo (Note: Set the transmitter under CCPM 120 degrees mode), pull throttle stick (pitch) upward. If one swashplate servo (or two servos) moves downward, adjust reverse switch (REV) on the transmitter to make it moves upward. If three servo move downward, adjust the travel value (+/-) of SWASH CH6 on the transmitter to make them move upward. When the actions of Aileron and Elevator are opposite, adjust travel values of SWASH CH2 and CH3.

CH2、CH6可互換配置，依圖連結後(注意：遙控器須設定於CCPM 120°十字盤模式)，將油門搖桿(Pitch)往上推，若十字盤伺服器有1個或2個往下移時，請調整遙控器的反轉開關(REV)使伺服器往上，若3個伺服器同時往下移時，請調整遙控器 SWASH CH6 行程量的正負值，使伺服器同時往上平移，副翼與前後動作相反時，同樣調整 SWASH CH2、CH3 行程量正負值。

### FUTABA/HITEC Transmitter/Servo FUTABA/HITEC遙控器對應伺服器關係

Pitch:CH6  
螺距:CH6

Aileron:CH1  
副翼:CH1

Aileron:CH1  
副翼:CH1

Pitch:CH6  
螺距:CH6

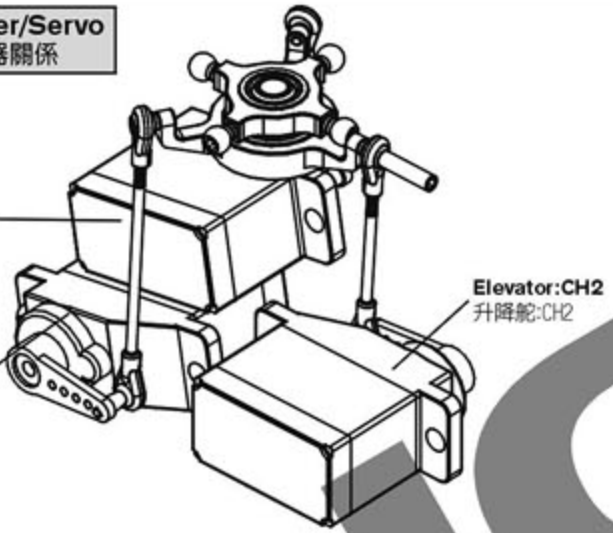

Positions of CH1、CH6 are exchangeable, After assembling as photo (Note: Set the transmitter under CCPM 120 degrees mode), pull throttle stick (pitch) upward. If one swashplate servo (or two servos) moves downward, adjust reverse switch (REV) on the transmitter to make it moves upward. If three servo move downward, adjust the travel value (+/-) of SWASH CH6 on the transmitter to make them move upward. When the actions of Aileron and Elevator are opposite, adjust travel values of SWASH CH1 and CH2.

CH1、CH6可互換配置，依圖連結後(注意：遙控器須設定於CCPM 120°十字盤模式)，將油門搖桿(Pitch)往上推，若十字盤伺服器有1個或2個往下移時，請調整遙控器的反轉開關(REV)使伺服器往上，若3個伺服器同時往下移時，請調整遙控器 SWASH CH6 行程量的正負值，使伺服器同時往上平移，副翼與前後動作相反時，同樣調整 SWASH CH1、CH2 行程量正負值。

# 12. ADJUSTMENTS FOR GYRO AND TAIL NEUTRAL SETTING 陀螺儀與尾翼中立點設定調整

Recommend to choose Head Lock type for Gyro and turn off Revolution mixing(RVMX) mode on the transmitter, then set the gain switch on the transmitter and the gyro to Head lock mode. The gain setting is about 70%, and after transmitter setting, connect to the helicopter power for working on tail neutral setting. **Note: When connecting to the helicopter power, please do not touch tail rudder stick and the helicopter. Then wait for 3 seconds, make tail servo horn and tail servo at a right angle(90 degrees), tail pitch assembly must be correctly fixed about in the middle of the travel of tail rotor shaft for standard neutral setting.**

陀螺儀選擇，建議選用鎖定式陀螺儀，且發射器內陀螺儀設定請關閉根軸混控模式，並將發射器上的感度開關與陀螺儀切至鎖定模式，感度設約 70% 左右，發射器設定完成後接上直昇機電源，即可進行尾中立點設置。注意：當接上直昇機電源時請勿撥動尾舵搖桿或碰觸機體，待3秒陀螺儀鎖定後尾伺服臂需與尾伺服器約成 90°，尾旋翼控制組須正確置於尾橫軸行程約中間位置，即為標準尾中立點設定。

### TAIL NEUTRAL SETTING 尾中立點設定

After setting Head Lock mode, correct setting position of tail servo and tail pitch assembly is as photo. If the tail pitch assembly is not in the middle position, please adjust the length of rudder control rod to trim.

陀螺儀鎖定後尾伺服器與尾 Pitch 控制組正確擺置位置。若尾 Pitch 控制組未置中時請調整尾控制連桿的長度來修正。

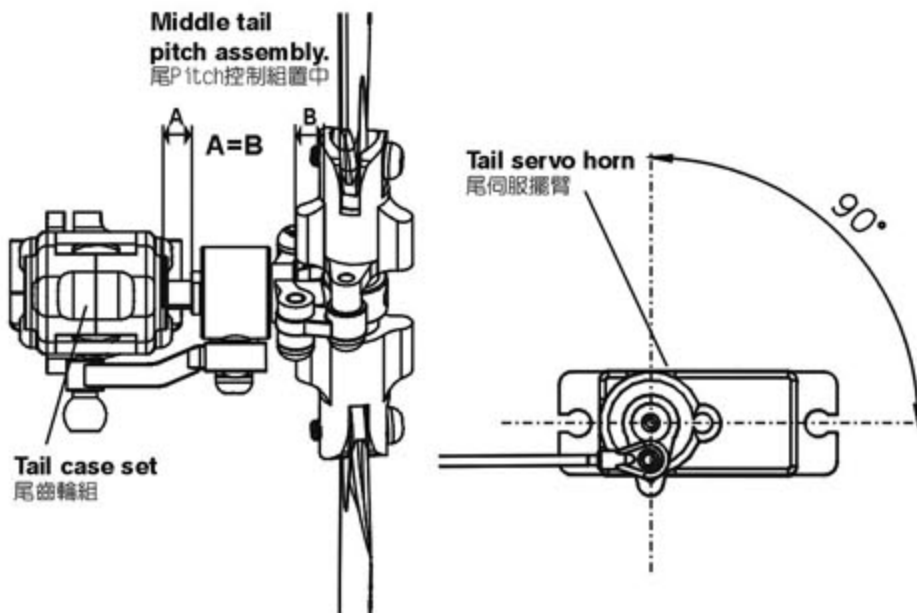

### HEAD LOCK DIRECTION SETTING OF GYRO 陀螺儀鎖定方向設定

To check the head lock direction of gyro is to move the tail counterclockwise and the tail servo horn will be trimmed clockwise. If it trims in the reverse direction, please switch the gyro to "REVERSE".

陀螺儀鎖定方向確認，當手搖尾部反時鐘擺動，尾伺服臂應反時鐘修正，反向時請切換陀螺儀上「鎖定反向」開關修正。

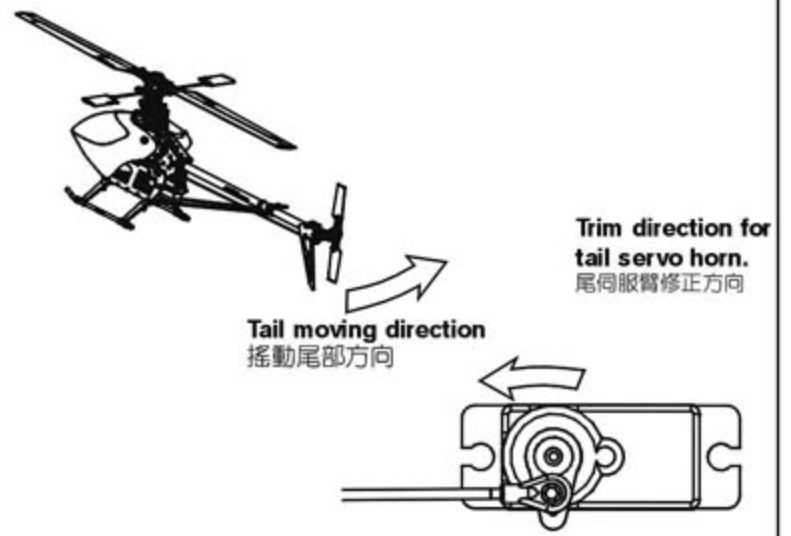

GENERAL FLIGHT 一般飛行模式

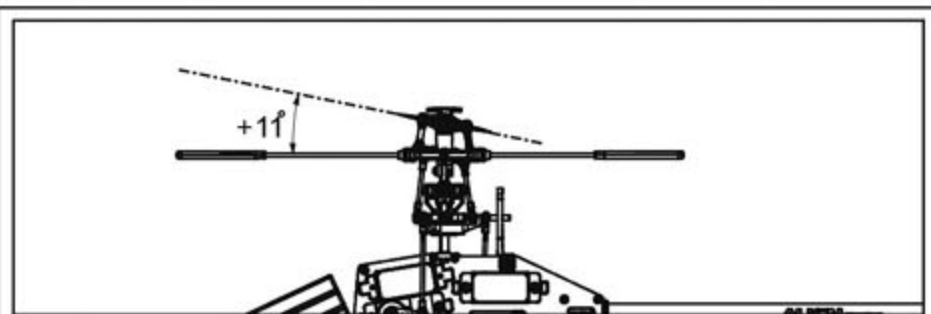

Stick position at high/Throttle 100%/Pitch +11°  
搖桿高速/油門100%/Pitch+11°

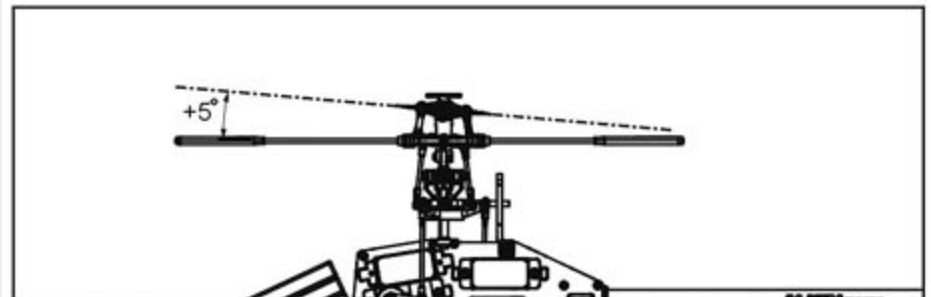

Stick position at Hovering/Throttle 70%~75%/Pitch +5°  
搖桿停懸/油門70%-75%/Pitch+5°

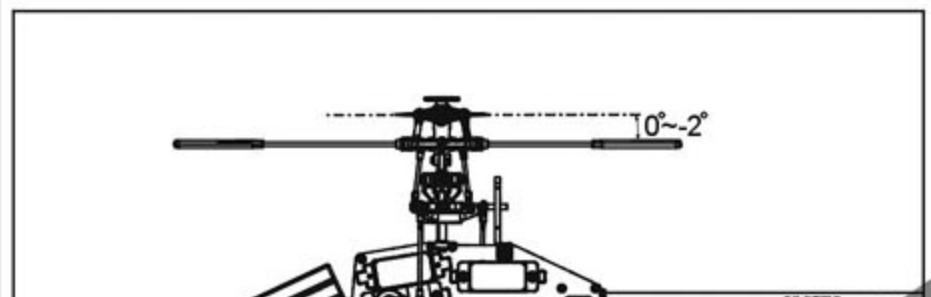

Stick position at low/Throttle 0%/Pitch -2°~0°  
搖桿低速/油門0%/Pitch-2°~0°

GENERAL FLIGHT 一般飛行模式

	Throttle 油門	Pitch 螺距
5	100% High speed 100% 高速	+11°
4	85%	
3	70%~75% Hovering 70%-75% 停懸	+4°~+5°
2	40%	
1	0% Low speed 0% 低速	-2°~0°

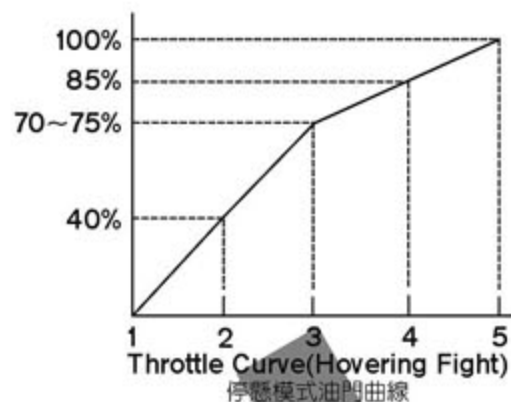

Pitch and Rotation Speed Pitch與轉速關係

TIP: It is recommended to use a lower pitch setting when using higher RPM/Head speed. This will allow for better power.  
搭配要領: 如果使用較高轉速馬達動力建議搭配調低 Pitch, 將獲得較佳動力效能。

3D FLIGHT 3D特技飛行模式



Stick position at high/Throttle 100%/Pitch +11°  
搖桿高速/油門100%/Pitch+11°

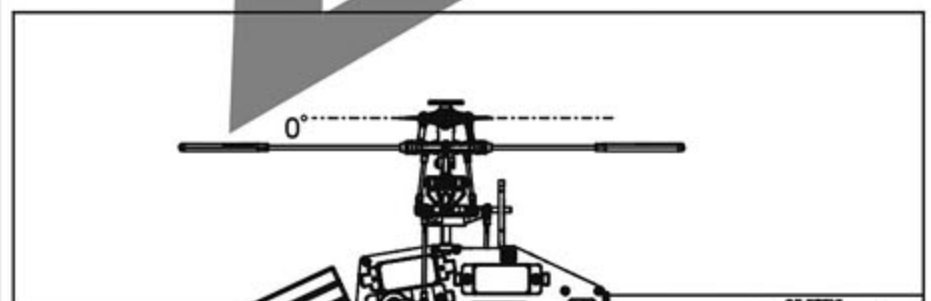

Stick position at middle/Throttle 85~90%/Pitch 0°  
搖桿中速/油門85-90%/Pitch 0°

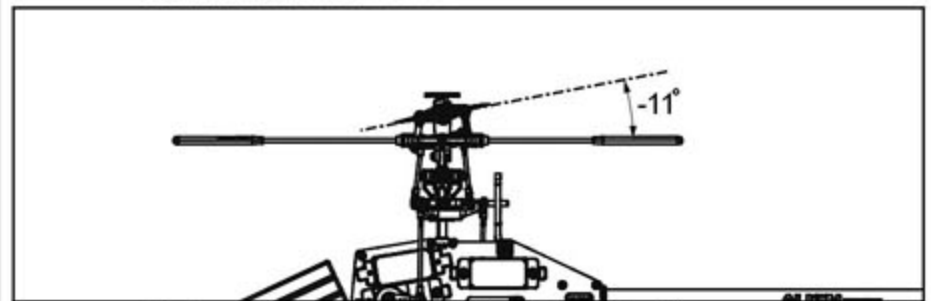

Stick position at low/Throttle 100%/Pitch -11°  
搖桿低速/油門100%/Pitch-11°

IDLE 1: SPORT FLIGHT

	Throttle 油門	Pitch 螺距
5	100%	+11°
4	75%	
3	70%	5°
2	75%	
1	80%	-11°

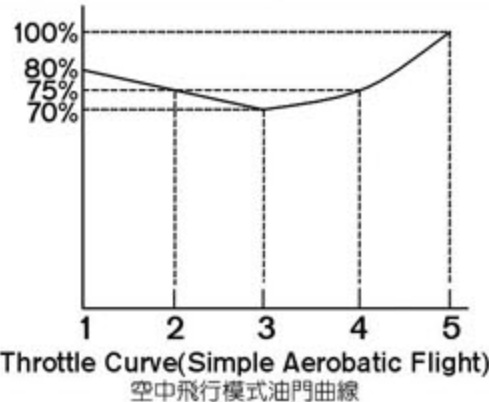

IDLE 2: 3D FLIGHT

	Throttle 油門	Pitch 螺距
5	100% High 100% 高	+11°
3	85~90% Middle 85-90% 中	0°
1	100% Low 100% 低	-11°

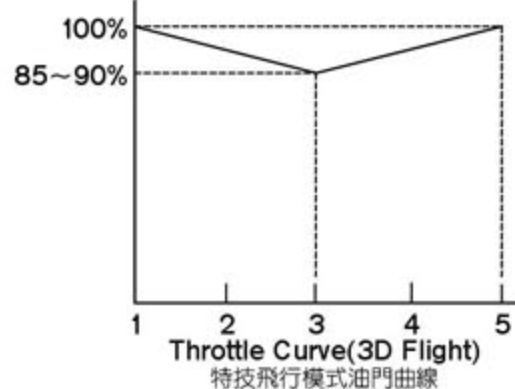

1. Pitch range: Approx 26° (±13°) degrees.
2. If the pitch is set too high, it will result in shorter flight duration and poor motor performance.
3. Setting the throttle to provide a higher speed is preferable to increasing the pitch too high.



1. 螺距 (Pitch) 總行程約 26° (±13°)。
2. 過大螺距設定, 會導致動力與飛行時間降低。
3. 動力提昇以較高轉速的設定方式, 優於螺距調大的設定。

**BATTERY電池：ALIGN Li-Poly 11.1V 850 mAh**

Motor Pinion Gear 馬達主齒	Main Rotor Blade 主旋翼規格	Pitch 螺距	Current(A) approx. 電流(A)大約值	Throttle Curve 油門曲線	RPM approx. 主旋翼轉速大約值	
15T	205 Main Blades 205主旋翼	Hover 停懸	+5°	3.9	0/50/70/85/100%	3520
		Idle	0°	4.2	85%中	4460
			0°	4.9	100/100/100/100/100%	4700
			±11°	10.4		4160
	205D Carbon Fiber Blades 205D主旋翼	Hover 停懸	+5°	3.8	0/50/70/85/100%	3530
		Idle	0°	4.0	85%中	4500
			0°	4.7	100/100/100/100/100%	4770
			±11°	10.1		4200

**NOTE: Please use a pitch gauge to adjust the pitch value. Incorrect excess pitch setting will result poor helicopter performance and reduce ESC's life and battery's life.**

註：請務必使用螺距規來量測調整螺距，不正確的過大螺距設定不但無法發揮直昇機的特性，反會影響到無刷調速器與電池的壽命。

15.RCE-BL15X BRUSHLESS SPEED CONTROLLER INSTRUCTION MANUAL 無刷調速器使用說明

**PRODUCT FEATURES 產品特色**

1. 5-6V step-less adjustable BEC output allowing custom voltage setting to match servo specification.
2. BEC output utilizing linear power system, suitable for 7.4-11.1V (2S-3S) Li battery, with continuous current rating of 2A, and burst rating of 3A.
3. Three programmable throttle speed settings to support quick throttle response.
4. Include soft start and Governor Mode.
5. Small and compact PCB design for lightweight and simple installation.
6. Large heat sink for optimum thermal performance.
7. Highly compatible to work with 98% of all brushless motors currently on the market.
8. Ultra-smooth motor start designed to run with all kinds of brushless motors.
9. The power inlet utilizes a Japanese made "Low ESR" capacitor in order to provide stable power source.
10. The throttle has more than 200 step resolution that provides great throttle response and control.

1. 5-6伏特無段可調式BEC輸出，可依伺服器規格與所需的特性自行設定電壓。
2. BEC輸入端採用線性電源設計，適用於7.4-11.1V (2S-3S) 鋰電，持續耐電流2A，瞬間3A。
3. 三段可程式油門反應速度，使動力的反應隨傳隨到。
4. 具緩啟動及Governor Mode定速功能。
5. 體積小，窄型設計，安裝於機身容易。
6. 有散熱片設計，可延長電變壽命。
7. 超高相容性，可對應市面上98% 無碳刷馬達。
8. 絕佳起步設計，無論國產、進口、內轉、外轉無刷馬達皆起步順暢。
9. 電池電源端採用日製 Low ESR 低阻抗電解電容，大幅提高電源之穩定性。
10. 油門達 200 段以上解析度，無格數之油門感覺。

**WIRING ILLUSTRATION 接線示意圖**

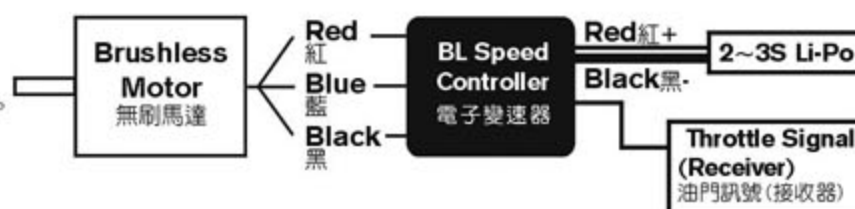

**SPECIFICATION 規格**

Model 型號	Continuous Current 持續	Peak Current 瞬間	BEC Output BEC輸出	Dimension 尺寸	Weight 重量
RCE-BL15X	15A	20A	Output voltage: 5-6V step-less adjustment Continuous current 2A; Burst current 3A 輸出電壓: 5-6V無段可調式 承受電流: 持續2A、瞬間3A	42x24x9.3mm	15g

1. Good temperature situation for working at the maximum current
2. Supporting motor types: 2 ~ 10 pole in/outrunner brushless motors.
3. Supporting maximum RPM: 2 pole → 190,000 rpm ; 6 pole → 63,000 rpm.
4. Input voltage: 5.5V ~ 12.6V(2~3S Li-Po)

**NOTE: When setting to the Quick throttle response speed, the accelerative peak current will increase.**

1. 持續最大電流需在機體散熱良好情況下。
2. 支援馬達型式: 二極至十數極之內外轉子無碳刷馬達。
3. 支援最高轉速: 二極→190,000rpm; 六極→63,000rpm。
4. 輸入電壓: 5.5V-12.6V (2-3s Li-Po)

注意: 設定為高油門反應速度時，加速瞬間電流會有增大情形。

**FUNCTIONS 產品功能**

1. Brake Option - 3 settings that include Brake disabled/Soft brake/Hard brake.
2. Electronic Timing Option - 3 settings that include Low timing/Mid timing/High timing. Generally, 2 pole motors are recommended to use low timing, while 6 or more poles should use Mid timing. High timing gives more power at the expense of efficiency. Always check the current draw after changing the timing in order to prevent overloading of battery.
3. Battery Protection Option- 2 settings that include Li-ion, Li-poly High/Middle cutoff voltage protection. The default setting is high cutoff voltage protection. CPU will automatically determine cell number of input Lithium battery (2S~3S). This option will prevent over-discharge of the battery. The following reference is the guideline for setting the Battery Protection option.

**3-1 Li-ion/Li-poly High cutoff voltage protection-**When the voltage of single cell drops to 3.2V, the first step of battery protection mode will be engaged by the ESC resulting in reduced power. The pilot should reduce the throttle and prepare landing. If the voltage of single cell drops to 3.0V, the second step of battery protection mode will be engaged resulting in power cutoff. (\*Note 1) For 11.1V/3cells Lithium battery, the full charged voltage will be approximately 12.6V.

According to this input voltage, CPU will determine that this is a 3cell battery.

First step protection:  $3.2V \times 3cell = 9.6V$

Second step protection:  $3.0V \times 3cell = 9.0V$

When the voltage drops to 9.6V, the power will be reduced. When the voltage drops to 9.0V, the power will be cut off.

**3-2 Li-ion/Li-poly Middle cutoff voltage protection-** This option is same as instruction 3-1, but when the voltage of single cell drops to 3.0V, the first step of battery protection will be engaged. When the voltage of single cell drops to 2.8V, the second step of battery protection will be engaged. (\*Note 1)

Note 1: Second step of battery protection only works when Aircraft mode is setting to the option 4-1.

NOTE: THIS OPTION IS ONLY SUITABLE FOR A FULLY CHARGED BATTERY PACK IN GOOD WORKING CONDITION.

**4. Aircraft Option: 3 settings that include Normal Airplane / Helicopter 1 / Helicopter 2.**

Normal Airplane Mode is used for general airplanes and gliders. When flying Helicopters, you can choose Helicopter 1 Mode, or Helicopter 2 Mode. Helicopter 1 Mode provides Soft Start feature. Helicopter 2 Mode provides Soft Start and Governor Mode.

**5. Throttle response speed: 3 settings that include standard/ Medium/ Quick throttle response speed.**

The default setting is "quick speed". Use this option to adjust the setting according to flight character. For example, setting at Medium or Quick speed for 3D and powerful flight to make the power response more quickly, but note the accelerative peak current and power expense will increase.

**6. BEC output voltage setting: 5-6V step-less adjustment.**

This option allows custom voltage setting. Default setting is 5.5V; please adjust the voltage according to the specification of the servo (speed and resistance). Prior to entering the setup mode, a voltmeter needs to be connected to the power inlet of the receiver (as illustration) to monitor the selected voltage. The voltage is set by varying the throttle stick position from low (5V) to high (6V).

The voltmeter needs to be connected to any un-use inlets "+" and "-" to measure the selected voltage.

將電壓表連接到任一未使用通道的 "+" 端及 "-" 端，以量測所選擇的電壓。

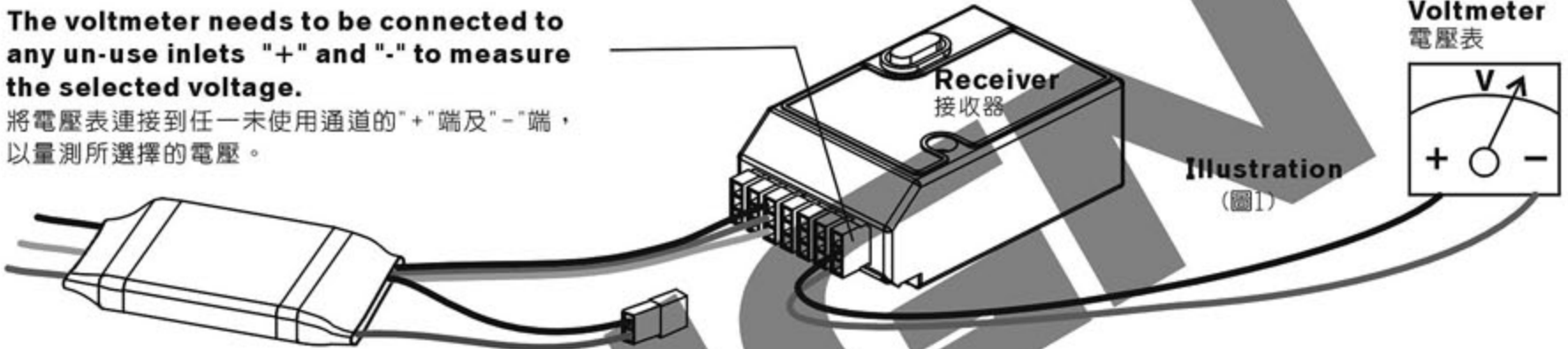

**NOTE: Certain servos are designed to work with high voltage, while other servos are designed for lower voltage. To avoid damage to servos, please follow the servo's factory specification to determine the proper voltage setting.**

注意:部份伺服器不適合較高的電壓下操作，請依原廠適用電壓規格設定，避免造成伺服器燒毀。

**7. Thermal Protection:** When the ESC temperature reaches 80°C for any reason, it will engage the battery protection circuit, reducing power to the ESC. We recommend mounting the ESC in a location with adequate air flow and ventilation.

**8. Safe Power On Alarm:** When the operator turns on the ESC, it will automatically detect the transmitter signal. The ESC will emit a confirmation tone and enter normal operation mode if the throttle is set to the lowest position. If the throttle position is at full throttle, it will begin to enter Setup Mode. If the throttle is in any other position, the ESC will emit an alarm and not enter into user mode for safety precautions.

**9. Aircraft Locator:** If the aircraft should land or crash in an unexpected location and become lost, the pilot can enable the Aircraft Locator Option. The Aircraft Locator Option is engaged by turning off the transmitter. When the ESC does not receive a signal from the transmitter for 30 seconds, it will start to send an alarm to the motor. The sound of the alarm will aid the pilot to locate the aircraft. This option will not work with a PCM receiver that has SAVE function enabled, or with low noise resistant PPM receivers.

1. 煞車設定:三段選擇分為無煞車 / 軟性煞車 / 急煞車

2. 進角設定:三段選擇分為低進角 / 中進角 / 高進角

設定時機分為二極以及六極以上無碳刷馬達，二極無碳刷馬達一般適用低進角，若希望馬達轉速提高，可將進角設定為中進角。六極以上無碳刷馬達一般適用中進角，若希望馬達轉速提高，可將進角設定為高進角。然而進角之調整需要注意電流之變化，避免電池過載，影響電池及馬達壽命。

3. 電池保護電壓設定:二段選擇分為 Li-Ion、Li-Po 高截止電壓保護/中截止電壓保護出廠設定為高截止電壓保護；此功能會自動判定所輸入鋰電池的cell數(2-3S)，並提供使用者對該電池之放電保護，以避免因放電電壓過低而造成電池損壞，以下為設定值之解說：

3-1 Li-Ion/Li-Po高截止電壓保護：當鋰電單cell壓降達3.2V時，電變會啟動第一階段保護，使動力間歇性中斷，此時使用者應將油門收小，準備降落；而當單cell電壓持續壓降達到3.0V時則會啟動第二階段保護，完全限制動力輸出(註1:僅在4-1選項"一般飛機模式"下才會啟動第二階段保護)。

例：以一個使用11.1V 3cell鋰電池之系統而言11.1V鋰電池充電電壓約12.6V，此輸入電壓CPU會自動判定為3cell鋰電。

第一階段保護:  $3.2V \times 3cell = 9.6V$  第二階段保護:  $3.0V \times 3cell = 9.0V$

當電壓降至9.6V時，動力會間歇性中斷，當壓降達到9.0V時則完全限制動力輸出。

3-2 Li-Ion/Li-Po中截止電壓保護:同3-1功能說明，但單cell壓降達到3.0V時，會啟動第一階段保護，單cell壓降達到2.8V時啟動第二階段保護(註1)。

注意:以上功能僅適用於充電，且功能正常的鋰電池。

4. 飛機模式設定:三段式選擇分為:一般飛機模式/直昇機模式1/直昇機模式2

使用於一般飛機或滑翔機時，請設定於一般飛機模式，使用於直昇機時可選擇直昇機模式1：具有緩啟動功能，或直昇機模式2：具有緩啟動及Governor Mode定速功能。

5. 油門反應速度設定:三段選擇分為標準/中速/快速

出廠設定值為"快速"油門反應速度，此功能提供使用者依所需的飛行特性來作適當的調整，例如3D飛機與劇烈的3D直昇機飛行時可設定為中速或快速，使動力反應更加快速、靈敏，但須注意提高油門反應速度時，加速瞬間電流與耗電量會有增大的情形。

6. BEC輸出電壓設定:5-6V無段調整

本功能提供使用者自行設定BEC輸出電壓，初始電壓為5.5V，使用者可依伺服器的規格與所需的特性(速度與扭力)自行更改設定；進入此項設定前，請先將電壓表連接到接收器的電源端(如圖1)，用以監看所選擇的電壓，設定時以油門搖桿的位置來決定輸出電壓，油門搖桿最低為5伏特，最高為6伏特，之間的電壓值可移動搖桿的位置任意設定。

7. 溫度保護:當電變因不良之空氣對流或是過載輸出導致溫度上升達80°C時，電變會啟動溫度保護，而使動力間歇性中斷，建議將電變裝置在機艙內空氣對流之位置，並實際使用電流量表測輸出電流，以達到電變之最佳效率。

8. 開機防暴衝提醒功能:當使用者開啓電變電源時，系統會自動偵測發射機之設定，如果發射機油門未置於最低點，或未置於最高點準備進入設定模式，馬達將不會轉動，同時會有警響提醒。

9. 尋機功能:當飛機降若再長草區無法以目視定位時，使用者可將發射機關閉，當電變無法接收來自接收機信號時，電變會於30秒後使馬達發出警響聲響，以利定位。此功能不適用於設定了 SAVE 功能之 PCM 接收機，或抗雜訊低之 PPM 接收機。

## SETUP MODE 設定模式

- Setup mode:** Make sure to connect the ESC to the throttle channel of the receiver. Please refer to the user manual of your radio system. The second step is to connect the 3 power-out signal pins to the brushless motor. Before you turn on the transmitter, please adjust the throttle stick to the maximum full throttle position. Proceed to connect the battery to the ESC. You will hear confirmation sounds as soon as you enter the SETUP MODE. Please refer the attached flow chart for details.
  - Throttle stick positions in Setup mode:** Setup mode includes six settings: Brake, Electronic Timing, Battery Protection, Aircraft, Throttle Response Speed and BEC output voltage. Every setting has three options. Simply place the throttle stick in the highest, middle, and lowest positions for each setting. For example, first brake setting (Hard): move the stick to the highest position. Then timing setting (mid): move the throttle stick in the middle position.
1. 進入設定模式: 將電變與接收器之油門 Channel 連接, 不同之遙控系統請參閱您遙控系統之使用手冊, 馬達之三條線亦與電變連接, 將發射器之油門搖桿推到最高點, 使之於全油門狀態, 先開啓發射器電源, 再將電源連接至電變, 進入設定模式後, 馬達將有設定模式之提示聲響。請參考第二頁程式化設定模式說明。
2. 設定模式中之動作: 設定模式共含有六項設定, 分別為煞車、馬達進角、電池保護、飛機模式、油門反應速度級 BEC 輸出電壓等設定, 詳細內容請參考產品功能之解說。每一項設定中各含三段設定, 各項設定以油門搖桿之上、中、下位置來決定其設定值。例如: 煞車設定時, 油門搖桿撥至最高, 則設定為急煞車, 進入第二項進角設定時, 油門搖桿撥至中間, 則設定為中進角。

Mode 設定模式	Throttle position 油門搖桿	Low 低	Middle 中	High 高
Brake 煞車設定		● Brake disabled(1-1) 無煞車 (1-1)	Soft brake(1-2) 軟性煞車 (1-2)	Hard brake(1-3) 急煞車 (1-3)
Electronic Timing 進角設定		Low-timing(2-1) 低進角 (2-1)	● Mid-timing(2-2) 中進角 (2-2)	High-timing(2-3) 高進角 (2-3)
Battery Protection 電池保護電壓設定		● High cutoff voltage protection(3-1) 高截止電壓保護 (3-1)	Middle cutoff voltage protection(3-2) 中截止電壓保護 (3-2)	—
Aircraft 飛機模式設定		Normal Airplane/Glider(4-1) 一般飛機 / 滑翔機 (4-1)	● Helicopter 1 (Soft Start)(4-2) 直升機模式1 (緩啟動功能) (4-2)	Helicopter 2 (Soft Start+ Governor Mode)(4-3) 直升機模式2 (緩啟動+Governor Mode定速功能) (4-3)
Throttle response speed 油門反應速度設定		Standard(5-1) 標準 (5-1)	Medium speed(5-2) 中速 (5-2)	● Quick speed(5-3) 快速 (5-3)
BEC output voltage BEC輸出電壓設定		5.0V	● 5.5V	6.0V

Note: "●" default setting  
註: "●" 表示出廠設定值

Chart A  
表A

## ESC START-UP INSTRUCTION 開機使用模式

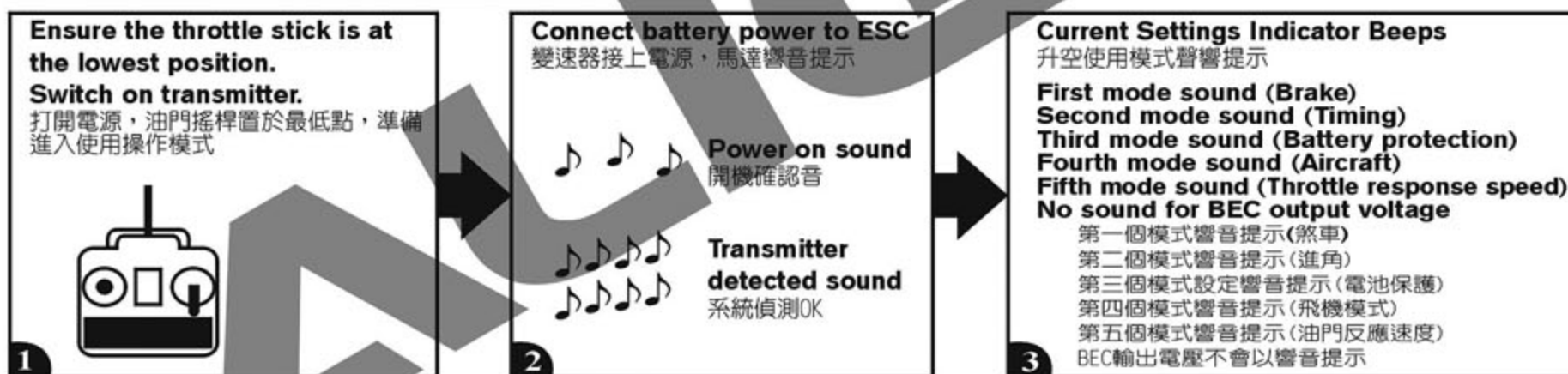

## CURRENT SETTINGS INDICATOR BEEPS EXPLANATION 開機模式設定響音提示說明

<p><b>First Beep Group Brake Status</b> 第一個響音 煞車設定狀態提示</p> <ul style="list-style-type: none"> <li>♪ = Brake disabled = 無煞車</li> <li>♪♪ = Soft brake = 軟性煞車</li> <li>♪♪♪ = Hard brake = 急煞車</li> </ul>	<p><b>Second Beep Group Electronic Timing</b> 第二個響音 進角設定狀態提示</p> <ul style="list-style-type: none"> <li>♪ = Low timing (apply to 2 pole inrunner motors) = 低進角 (適合2級內轉子馬達)</li> <li>♪♪ = Mid timing (apply to 6 pole in/out unner motors) = 中進角 (適合6級內外轉子馬達)</li> <li>♪♪♪ = High timing (apply to high power output) = 高進角 (適用於高功率輸出)</li> </ul> <p><b>High-timing/big power/power expense</b> 高進角模式有較大功率與耗電特性</p>
<p><b>Third Beep Group Battery protection Cutoff</b> 第三個響音 電池保護設定狀態提示</p> <ul style="list-style-type: none"> <li>♪ = High cutoff voltage protection = 高截止電壓保護</li> <li>♪♪ = Middle cutoff voltage protection = 中截止電壓保護</li> </ul>	<p><b>Fourth Beep Group Aircraft Status</b> 第四個響音 飛機模式設定狀態提示</p> <ul style="list-style-type: none"> <li>♪ = Normal airplane/Glider = 一般飛機 / 滑翔機</li> <li>♪♪ = Helicopter 1 (Soft start) = 直昇機模式1 (緩啟動功能)</li> <li>♪♪♪ = Helicopter 2 (Soft start + Governor Mode) = 直昇機模式2 (緩啟動功能 + Governor Mode定速功能)</li> </ul>
	<p><b>Fifth Beep Group Throttle Response</b> 第五個響音 油門反應速度設定狀態提示</p> <ul style="list-style-type: none"> <li>♪ = Standard = 標準</li> <li>♪♪ = Medium speed = 中速</li> <li>♪♪♪ = Quick speed = 快速</li> </ul>



## INSTRUCTIONS ON AIRCRAFT MODE SETTINGS 飛機模式設定使用說明

### Normal Airplane/Glider Mode (Option 4-1):

This option is applied to general airplanes and gliders.

### Helicopter 1 Mode (Option 4-2):

This option provides a soft start feature and is applied to Helicopters for Normal, Idle Up 1, or Idle Up 2 modes.

Please note that the sensitivity of the gyro should be set lower when flying in Idle Up 1 or Idle Up 2 modes if tail hunting (wag) occurs due to higher rotor speed.

### Helicopter 2 Mode (Option 4-3):

This option supports soft start as well as Governor Mode features and is applied to Helicopters for Idle Up 1 and Idle Up 2 modes (not suitable for Normal Flight Mode). When Governor Mode is in use, the throttle should be set between 75% and 85%. Again if tail wag occurs, lower the sensitivity of the gyro to eliminate the hunting effect. The Governor Mode may not work properly in cases of insufficient rotor speed (due to improper gear ratio), poor battery discharge capability, and improper setting of gyro sensitivity and the blade pitch, etc. Please make sure all the proper adjustments have been done when using Governor Mode.

一般飛機模式(選項4-1):適用於一般飛機及滑翔機。

直昇機模式1(選項4-2):具有緩啟動功能,適用於Normal、Idle1、Idle2等飛行模式,當切換至Idle1或Idle2模式,如有較高轉速造成陀螺儀有輕微的追蹤現象,此時應將陀螺儀的感度設定分別降低。

直昇機模式2(選項4-3):具有緩啟動及Governor Mode定速功能,適用於Idle1、Idle2特技飛行模式(不適合Normal飛行模式下選用),選擇定速功能時,油門應定速在75%-85%之間,如果飛行時發現有輕微的追蹤現象時,應降低陀螺儀的感度;由於轉速不足(齒比搭配不當),電池效能不佳,陀螺儀感度設定不當,Pitch設定錯誤,皆會導致無法發揮定速的功能,甚至產生尾部偏擺的情形,所以選擇此模式時應針對相關條件進行確認。

## SETUP MODE 程式化設定模式

Minimum 4 channel radio is required 四動以上標準發射器均可執行設定

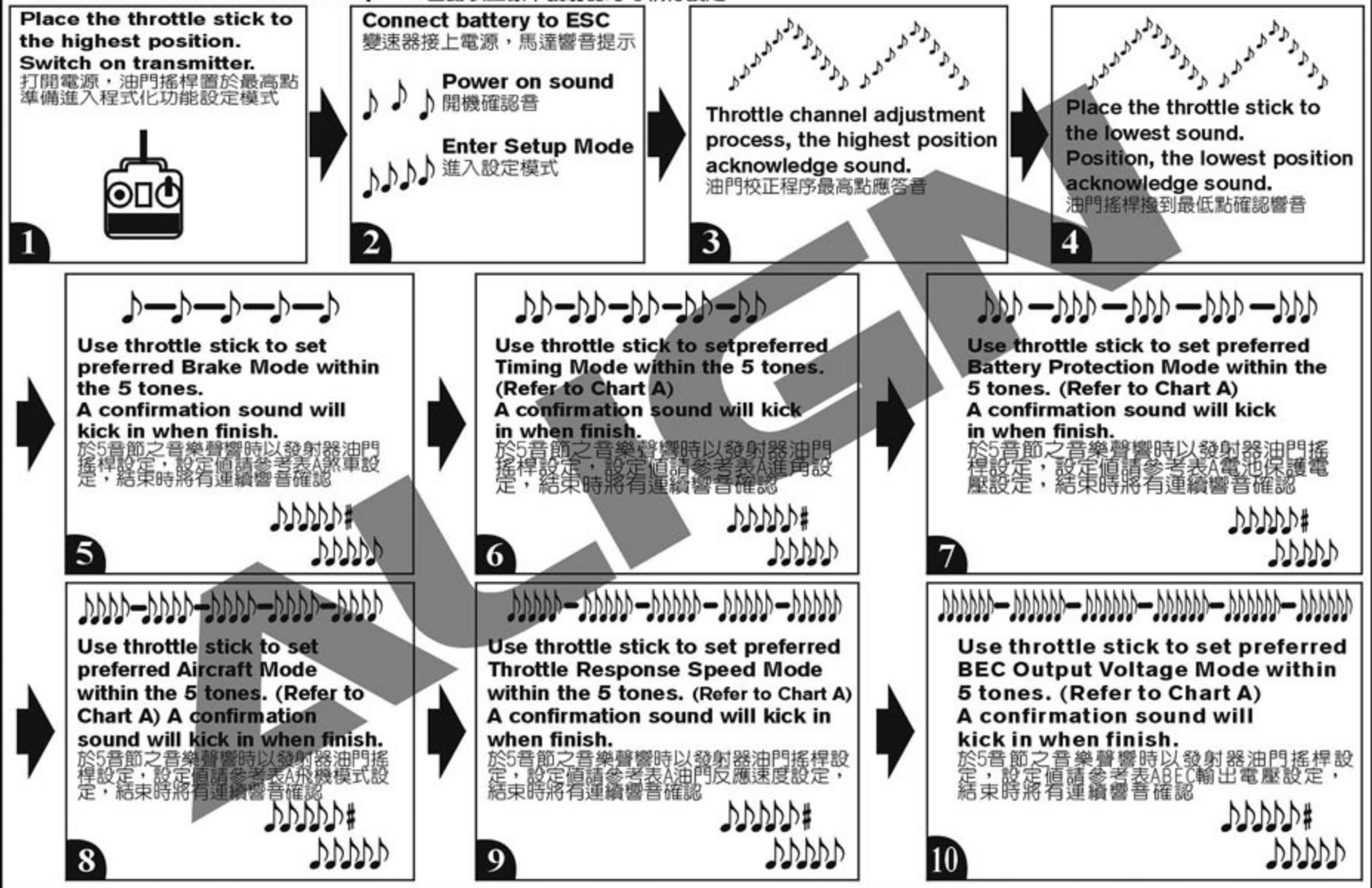

## 16.GP790 HEAD LOCK GYRO SET USER MANUAL GP790鎖定式陀螺儀組使用說明

ALIGN

### Features 產品特色

- Utilizes MEMS gyro sensors, which feature small footprint, high reliability, and excellent stability.
- Utilizes AHTCS (Active Helicopter Tail Control System) to compensate any drift caused by wind direction and force, as well as unintended yaw induced by helicopter itself during flight maneuvers.
- Tailor made specifically for use with high speed digital rudder servos. This gyro features high sensitivity and minimal reaction time, fully utilizing the potential of modern high speed digital rudder servos.
- Suitable for all sizes of helicopters, from micro indoor to large 90 size glow helicopters.
- Superior vibration filtration routine, dramatically minimizes vibration and interferences.
- Features 1520  $\mu$ s pulse wide and 760  $\mu$ s narrow pulse wide frame rate.
- Digital/Analog servo switchable.
- Reverse switch.
- Rudder servo travel limit adjustment (ATV).
- Mode switch for large/mini helicopter.
- Delay adjustment.
- Gyro locking mode and gain can be adjusted remotely from the transmitter.

- 採用MEMS (Micro Electro Mechanical Systems) 微機電系統技術感測器，具有體積小，可靠性高，穩定性佳的優點。
- 採用AHTCS (Active Helicopter Tail Control System)主動式直昇機尾旋翼控制系統，主動修正因風向、風力變化與直昇機不同飛行姿態所產生之偏移。
- 專為高速型數位伺服器量身打造，具有高靈敏度與極短的反應時間，完全發揮伺服機高速反應的鎖定能力。
- 適用迷你型室內電直至大型90油直。
- 優異抗震濾波程式，大幅提升抗震防干擾能力。

- 相容標準1520 $\mu$ s與窄頻760 $\mu$ s伺服器。
- 數位/類比伺服器切換。
- 尾舵正逆向控制切換。
- LIMIT尾舵行程量設定。
- 大/小型直昇機模式切換。
- DELAY控制延遲量設定。
- 可由遙控器控制鎖定與非鎖定模式，以及調整陀螺儀感度。

### Program setting table 程式設定對照表

Setting type 設定項目	1520/760 $\mu$ s	DS/AS	NOR/REV	LIMIT	Helicopter mode / DELAY 直昇機模式/DELAY
"STATUS"green "STATUS"綠燈	▲Standard 1520 $\mu$ s Servo ▲標準1520 $\mu$ s伺服器	▲Digital servo ▲DS數位伺服器	▲Normal rotation ▲NOR正轉	Left(Right)Travel limit 左(右)行程量	Medium/ large heli, suitable for T-REX500/600/700 中型/大型直昇機 適用T-REX500/600/700
"STATUS"red "STATUS"紅燈	Narrow band 760 $\mu$ s Servo 窄頻760 $\mu$ s伺服器	Analog Servo As類比伺服器	Reverse rotation REV反轉	Right(Left)Travel limit 右(左)行程量	Mini/ Micro heli, suitable for T-REX250/450 小型/迷你型電直 適用T-REX250/450
Setting instruction 設定方式說明	See no. 2 in setting instructions 參照設定方式第2項	See no. 3 in setting instructions 參照設定方式第3項	See no. 5 in setting instructions 參照設定方式第5項	See no. 6 in setting instructions 參照設定方式第6項	See no. 8 in setting instructions 參照設定方式第8項

NOTE : 1. "▲"Default setting. 2. Wrong heli mode will affect the performance of gyro. Do not fly before the complete setting.  
註：1. "▲"表示出廠設定值。 2. 錯誤的直昇機模式將影響陀螺儀性能，未完成設定前請勿飛行。

### T-REX250 Standard setting T-REX250標準設定

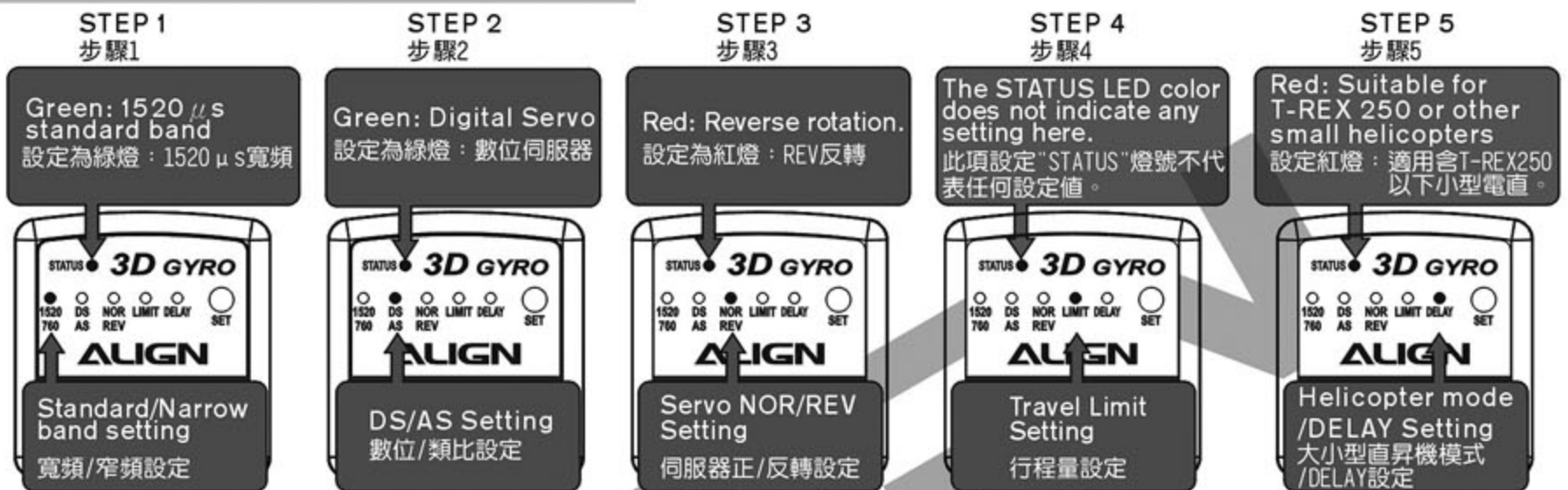

### Diagram 各部名稱

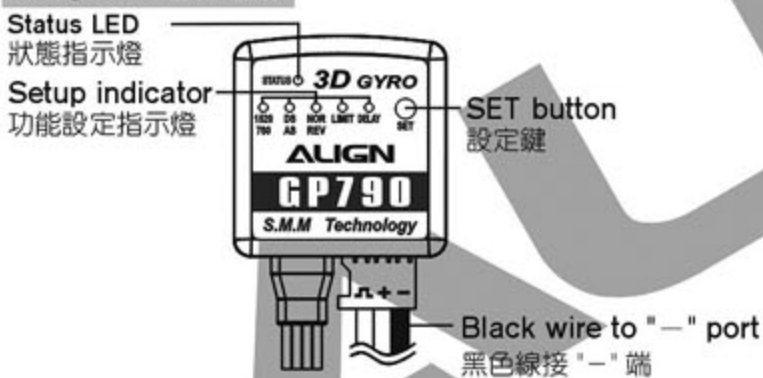

### GP790 Gyro Specifications GP790陀螺儀產品規格

- Operating Voltage: DC 4.5~8.4V
  - Current Consumption: <80mA @ 4.8V
  - Angular Detection Speed:  $\pm 500$  degrees/sec
  - Operating Temperature:  $-20^{\circ}\text{C} \sim 65^{\circ}\text{C}$
  - Operating Humidity: 0%~95%
  - Size: 26.2x25.2x8.7mm
  - Weight: 7.5g
  - RoHS compliant
- 適用電壓: DC 4.5~8.4V
  - 消耗電流: <80mA @4.8V
  - 偵測角速度  $\pm 500$ 度/sec
  - 操作溫度:  $-20^{\circ}\text{C} \sim 65^{\circ}\text{C}$
  - 操作濕度: 0%~95%
  - 尺寸: 26.2x25.2x8.7mm
  - 重量: 7.5g
  - 符合RoHS限用規章

### DS420 Digital Servo DS420數位伺服器

- Speed: 0.08sec /60 degrees(4.8V)  
0.06sec /60 degrees(6.0V)
- Torque: 0.75kg.cm (4.8V)  
1.0kg.cm (6.0V)
- Dimension: 22.8 x 12 x 25.4mm
- Weight: 12.7g(Servo horn not included)
- 1520  $\mu$ s (standard band)
- 動作速度: 0.08sec/60° (4.8V)  
0.06sec/60° (6.0V)
- 輸出扭力: 0.75kg.cm(4.8V)  
1.0kg.cm(6.0V)
- 尺寸: 22.8x12x25.4mm
- 重量: 12.7g(不含舵角片)
- 1520  $\mu$ s(寬頻系統)

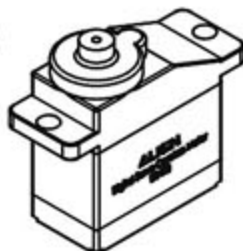

### Illustration 接線示意圖

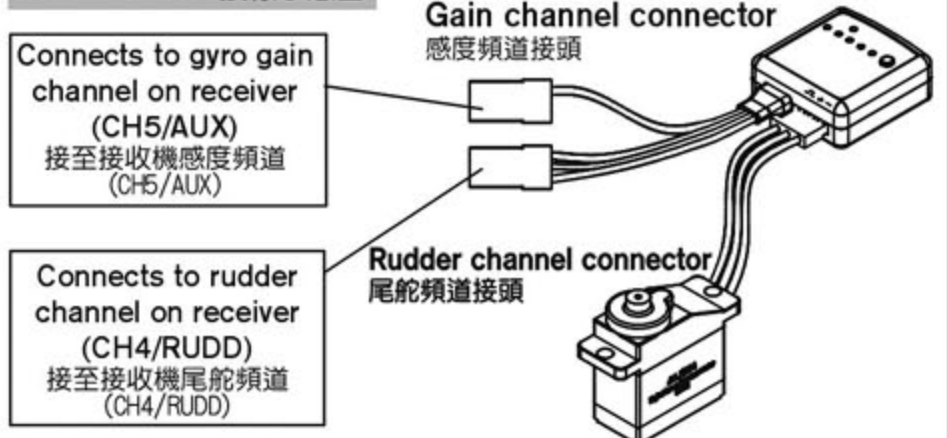

GP790 contains many function settings. In order to use it more smoothly and bring up the function of the gyro, please read and understand the following illustrations:

- The first function setting of GP790 is 1520  $\mu$ s (standard) or 760  $\mu$ s (narrow band) servo selection. Please set 1520  $\mu$ s (standard) for all Align DS series digital servos, which has green STATUS LED.  
※CAUTION◎ Only set 760  $\mu$ s (narrow band) when using FUTABA S9256, S9251, and BLS251 servos.  
◎If you set 760  $\mu$ s (narrow band) instead of 1520  $\mu$ s (standard) when using Align DS series digital servos, it will cause the rudder servo deflect to the side and unable to center. The limit will be really little and unable to function normally. The servo will be jammed because of the tail control assembly has an exceed travel limit. The servo will be burned out if holding this condition for 30 seconds.
- The DELAY setting of GP750 is not only control the delay but also the helicopter mode. Red STATUS LED is for T-REX 250/450 and green STATUS LED for T-REX 500/600/700. Please always remember to set the STATUS LED to red when paired with a T-REX 250 or any adjustment may cause tail slides and bad locking result.
- Please install the round servo horn set into DS420 servo (the most inner hole, 4.5mm to the mid-point of rudder piece).
- Please set the pitch of AIL, ELE and PIT 40%~45% from the SWASH setting in the transmitter. The pitch of the main blade should be set between  $10^{\circ} \sim 11^{\circ}$ . Suggested not set over  $11^{\circ}$  or the instant movement may happen when push the throttle rapidly.

GP790具有多項的功能設定,為了讓您在使用的上更加的順手,使陀螺儀的性能得以發揮,請務必在使用前詳細閱讀以下說明!

1. GP790第一項功能設定為寬頻1520 $\mu$ s/窄頻760 $\mu$ s伺服器選擇,使用亞拓DS系列數位伺服器請務必設定為寬頻1520 $\mu$ s,即"STATUS"指示燈為綠燈。

※注意:◎目前市面上採用760 $\mu$ s系統的伺服器只有FUTABA的S9256、S9251、BLS251。

◎寬頻1520 $\mu$ s伺服器若設錯為窄頻760 $\mu$ s功能時,將造成伺服器中立點偏向一邊,而且動作行程非常小無法正常運作,而直昇機尾控制組也會因此超過最大行程使伺服器卡死,此錯誤狀態若持續30秒將導致伺服器燒毀。

2. GP790第五項DELAY功能設定除了控制延遲量外,同時還兼具大、小型直昇機的選擇,"STATUS"指示燈為"紅燈"時適用250/450機型;"綠燈"時適用500/600/700機型,用於T-REX 250時務必設於紅燈,否則無論感度如何調整都可能造成擺尾或鎖定效果明顯差。

3. DS420尾伺服器請安裝圓形的舵角片,孔位請安裝於最內孔,與舵片中心距離為4.5mm。

4. 請將遙控器裡的SWASH設定:副翼(AIL)、升降(ELE)、螺距(PIT)的控制量設在約40%~45%,主旋翼的最大螺距大約在10°~11°間的表現最佳,建議不要超過11°,過大的螺距設定與主旋翼轉速不足,將導致螺距瞬間推到最大時造成擺尾的情形。

### Gain and Rudder channel mapping diagram 連接對照表:

Transmitter type 遙控器種類	Rudder channel on Receiver 尾舵頻道接頭至接收器	Gain channel on Receiver 感度頻道接頭至接收器
JR PPM/SPCM	"RUDD"	"AUX 2" or "AUX 3"
Hitec、Futaba PPM/PCM	"CH4"(RUD)	"CH5"
JR ZPCM	"RUDD"	"AUX 2"

### Gyro Installation 陀螺儀的安裝

1. Utilizing the included double sided foam tape as shown in diagram below, mount the gyro on a solid platform or designated gyro mounting location on the helicopter. Ensure gyro mounting area have proper ventilation and away from heat sources.

2. To avoid drift induced by erroneous yaw detection, the bottom surface of gyro must be perpendicular (90 degrees) relative to the main shaft.

3. For installation on electric powered helicopters, the gyro should be installed as far away from the electronic speed controller (ESC) as possible to avoid interference (minimum 5cm).

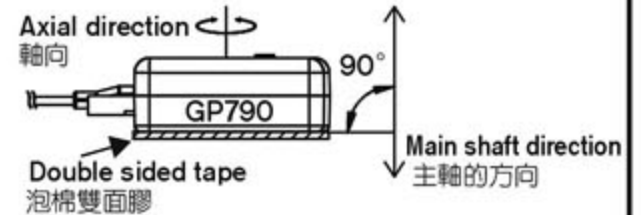

1. 利用所提供的泡棉雙面膠如下圖方示,把陀螺儀固定在穩定的平台上或機體預留的陀螺儀座,並確保它在通風良好的區域,遠離熱源。

2. 陀螺儀底部水平貼附與直昇機的主軸呈垂直90度,否則會影響感知器對角度變化的偵測,造成偏移。

3. 安裝於電動直昇機時盡量遠離(5公分以上)馬達與電子調速器,避免干擾情形發生。

### Usage Setting Instructions 使用及設定方式

1. **Transmitter Settings:** After powering up transmitter, make sure rudder subtrim is zeroed. Then power on the receiver and gyro. The gyro will go through initializing process indicated by flashing LED from left to right. Do not touch the heli or transmitter sticks until initializing is complete, as indicated by a steady lit LED. A green LED indicates gyro is in AHTCS locking mode, while red LED indicates gyro is in normal mode.

**Note:** The GP790 is set to 1520  $\mu$ s at the factory. If 760  $\mu$ s servo is used in 1520  $\mu$ s mode, rudder servo will deflect to the side and unable to center. For more critically, the linkage rod may jam and cause the servo burned out. Please follow the instruction (Usage setting 2) to change the setting if 760  $\mu$ s servo is used.

Please ensure the following mixing functions (if available) are disabled or zeroed on the transmitter.

- ATS
- Pilot authority mixing
- Throttle to rudder mixing
- Rudder to gyro mixing
- Pitch to rudder mixing
- Revolution mixing

2. **1520  $\mu$ s (standard) or 760  $\mu$ s (narrow band) servo selection:** GP790 offers compatibility for two types of frame rates under digital mode. Please set the GP790 to 760 mode if 760  $\mu$ s frame rate rudder servos (such as Futaba S9256, S9251, BLS251) are used. Most other servos have 1520  $\mu$ s frame rate, and GP790 should be set to 1520 mode if those servos are used.

**To enter the setup mode:** Press and hold the SET button for 2 seconds, and the STATUS LED will begin flashing. When the 1520/760 indicator lit up, you are in the servo frame rate setup menu. Use the rudder stick on your transmitter to select the frame rate: move the stick to left (or right) and STATUS led changes to green, the frame rate has been set to 1520  $\mu$ s. If you want to set the frame rate to 760  $\mu$ s, move the stick to opposite end 3 times to make STATUS led changes to red. (Note: The faceplate of GP790 has the setting values listed in the corresponding green/red letters.) Press the SET to confirm the current setting and enter the next setting. The GP790 will exit setting mode if left idle for 10 seconds.

1. 檢查遙控器的設定:先開啟遙控器電源,將尾舵的微調歸零後,再開啟直昇機的接收機電源,此時陀螺儀會先進入初始化狀態,所有指示燈會由左至右閃爍,接著使尾舵伺服器回到中立點,在此之前請勿晃動直昇機或撥動尾舵搖桿,當狀態指示燈為綠色時表示陀螺儀在鎖定的狀態,指示燈為紅色時表示陀螺儀在非鎖定的狀態。

※註:GP790出廠時內建為1520 $\mu$ s系統,若使用760 $\mu$ s窄頻伺服器時,開機後尾伺服器將會偏向一邊無法置中,甚至造成連桿卡死而使伺服器燒毀,請參照使用及設定方式第2項更改設定值。

如果您的遙控器有下列功能時,請設定為關閉(OFF)或數值設定為零

- ATS
- Pilot authority mixing
- Throttle to rudder mixing
- Rudder to gyro mixing
- Pitch to rudder mixing
- Revolution mixing

2. 1520 $\mu$ s(標準)或760 $\mu$ s(窄頻)伺服器選擇:GP790相容兩種波寬控制系統,若您使用的伺服器屬於760 $\mu$ s系統(如Futaba S9256、S9251、BLS251),則必須將GP790設定於760的模式,其他未標示760 $\mu$ s規格的伺服器,一般皆為1520 $\mu$ s系統,必須將GP790設定為1520的模式。

如何進入功能設定模式:持按面板上的"SET"設定鍵約2秒,此時"STATUS"狀態指示燈會開始閃爍,且"1520/760"的功能設定指示燈會亮起,表示進入標準/窄頻伺服器選項,利用遙控器方向舵搖桿的左右方向來選擇設定值,例如方向舵搖桿往左(或右)時,"STATUS"指示燈為綠色,表示設定值為1520 $\mu$ s系統;若要設定為窄頻760 $\mu$ s系統時,必須將搖桿由中立點往相反方向連續撥動3次,使"STATUS"指示燈亮紅色,才會進入760 $\mu$ s系統。(註:GP790的面板標籤上已使用綠/紅色的字體提示"STATUS"燈色所代表的設定值)。設定完成後按"SET"鍵一次可進入下一個設定,或是10秒內不做任何設定,GP790會自動離開設定模式。

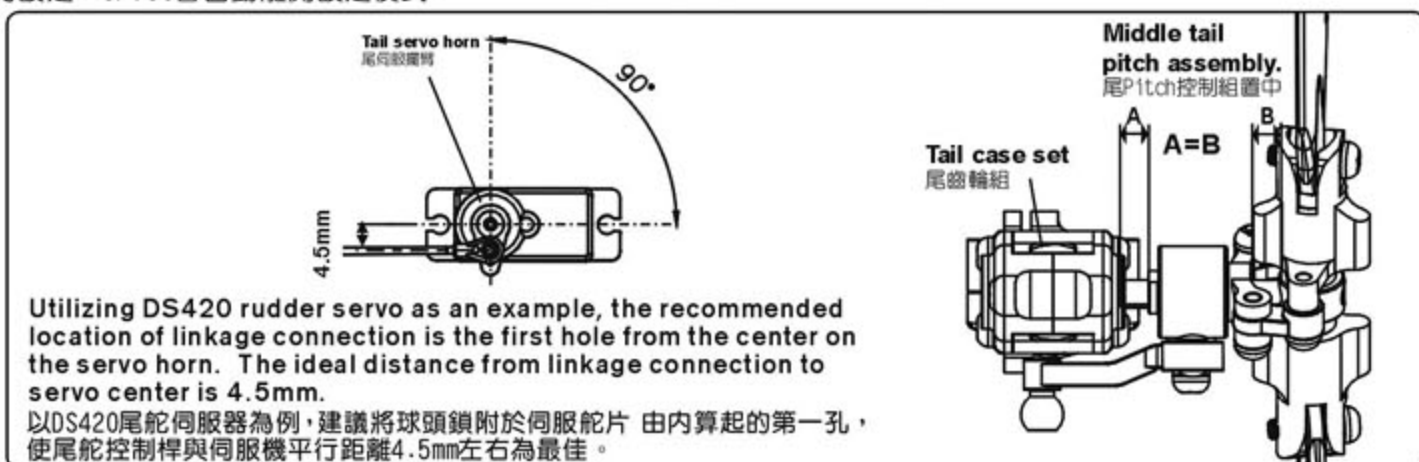

Utilizing DS420 rudder servo as an example, the recommended location of linkage connection is the first hole from the center on the servo horn. The ideal distance from linkage connection to servo center is 4.5mm.

以DS420尾舵伺服器為例,建議將球頭鎖附於伺服舵片由內算起的第一孔,使尾舵控制桿與伺服機平行距離4.5mm左右為最佳。

- 3. Digital (DS) / Analog (AS) Servo Selection:** Servo speed is of paramount importance in maximizing the gyro's performance. Fast servos are able to respond to gyro commands quickly, resulting in the speed and precision of overall system. Due to the high sensitivity of GP790 gyro, high speed digital servos such as Align DS420, DS520, Futaba S9257, S9256, S9254, S9253, or other similar spec servos are recommended. Select "DS" when digital servos are used, and "AS" when analog servos are used.
- To enter the setup mode:** Press and hold the SET button for 2 seconds, and the STATUS LED will begin flashing. Press the SET button repeatedly until DS/AS led is lit. Use the rudder stick on your transmitter to select the Servo type: move the stick to left (or right) and STATUS led changes to green, the servo type is set to DS. Move the stick to opposite direction and STATUS led changes to red, the servo type is set to AS.
- Warning:** The use of analog servo under "DS" mode will result in servo failure. The GP790 gyros are set to "DS" mode at the factory. Please set the proper servo type based on servo used.
- 4. Check the direction of rudder:** Move the rudder stick on transmitter left/right and check the helicopter's instruction manual for correct rudder direction. Servo reverse function on the transmitter can be used for reversed rudder.
- Set the transmitter gyro gain channel to normal mode, or press and hold the SET button for 2 seconds to center the rudder servo. Adjust the servo horn so it is perpendicular (90 degrees) relative to the pushrod. Then adjust the rudder linkage length so the tail pitch control system is within range.
- 5. Setting of gyro direction nor/rev:** Check the gyro direction by moving the heli on the yaw axis while holding by hand. Observe the direction gyro is moving the rudder servo. If direction is incorrect, switch the direction switch on the gyro to compensate.
- To enter the setup mode:** Press and hold the SET button for 2 seconds, and the STATUS LED will begin flashing. Press the SET button repeatedly until NOR/REV led is lit. Use the rudder stick on your transmitter to select the Servo type: move the stick to left (or right) and STATUS led changes to green, the servo direction is set to NOR. Move the stick to opposite direction and STATUS led changes to red, the servo direction is set to REV.
- Warning:** Flying with reversed gyro will cause the heli to spin out of control. Please double check the direction before attempting to fly the heli.
- 6. Rudder Servo Travel Limit Adjustment:** Press and hold the SET button for 2 seconds until the STATUS LED flashes.
- At this point the rudder servo will be centered. Press the SET button repeatedly until LIMIT led is lit. While observing the heli tail, gradually move the rudder stick on your transmitter left until the tail pitch slider reaches its mechanical end (without binding), then center the rudder stick and wait 2 seconds until STATUS LED flashes red. Now perform the same for right rudder: move the rudder stick on your transmitter right until the tail pitch slider reaches the other end, center the stick and wait 2 seconds for LED to flash again. This will set the travel limit of the servo on both sides.
- Insufficient rudder servo travel limit will result in decreased rudder performance, while excessive rudder servo travel will overload the rudder servo and cause failures.
- Warning:** Rudder travel setting can not be below 50%, or else GP790 will not register the settings. If excessive travel is observed even after performing the above rudder travel adjustments, please relocate the rudder servo linkage ball closer to the center of servo horn.
- 7. Gyro Gain Adjustments:** For radio with GYRO function, gain can be adjusted using this function. The AHTCS (heading lock) gain is set by adjusting the GYRO setting between 50% to 100%, while the normal mode gain is set by adjusting the GYRO setting between 0 to 49%. Actual gain settings will differ amongst different helis and/or servo. The goal is to achieve as high of gain as possible without the tail oscillating (wagging), therefore such adjustment can only be done under actual flight conditions. Suggested initial settings are 65% during hover, and 60% during idle-up conditions. Gyro gain can be increased or decreased after observing the presence of tail oscillation during flights.
- Note:** For radio systems using 0-100% as gain adjustment under heading lock mode (such as Futaba), the recommended gain setting is approximately 20%. For radio system using 50-100% as gain adjustment under heading lock mode (such as JR and Hitec), the recommended gain setting is approximately 65%.
- 8. Helicopter mode and delay setting. These settings incorporates two functions:**
- (1) GP790 supports mini/micro indoor helicopters. Set the setting based on the appropriate helicopter class.
- For example: Set the helicopter mode to mini/micro setting (Status LED turns red) for T-Rex 250 and 450; set the helicopter mode to medium/large setting (Status LED turns green) for T-Rex 500/600/700.
- (2) Slow rudder servos may cause tail oscillation as it receives the faster signal from gyro. If tail oscillation occurs after hard stop from stationary pirouette, increase the gain setting until such oscillation stops.
- Generally the delay value should be as low as possible, and used only to compensate for slower servos.
- Setting Method:** Press and hold the SET button for 2 seconds to enter the setup menu, and select DELAY setting. Push the rudder stick left or right and observe the STATUS LED. RED STATUS represents mini/micro helis such as T-REX250/450, GREEN STATUS represents medium/large helis such as T-REX500/600/700. The amount of delay is set by holding the rudder stick at the position corresponding the delay percentage, 0% at middle stick position (DELAY STATUS LED is flashing) and 100% at the end position, and pressing the SET button to confirm the delay setting.
3. DS數位/AS類比伺服器選擇：伺服器動作速度與靈敏度的性能，伺服器動作愈快，就能立即反應陀螺儀送出的指令，發揮快速精準的效能；由於GP790具有相當快速的反應時間與靈敏度，所以建議您搭配高速型數位伺服器，如ALIGN DS620、DS420、Futaba S9257、S9256、S9254、S9253或其他相同規格伺服器，以獲得最佳效能。設定方式：持按"SET"鍵2秒進入功能設定模式，再按"SET"鍵選擇DS/AS選項，(DS/AS指示燈亮起)，利用方向舵搖桿選擇數位DS (STATUS為綠燈)或類比AS (STATUS為紅燈)伺服器。
- 注意：在DS模式下連接類比伺服器將導致伺服器燒毀，本產品出廠時設定在DS模式，請自行依所搭配的伺服器類型選擇正確的模式。
4. 檢查尾舵伺服器正逆轉方向與調整連桿：左右撥動尾舵搖桿，確認尾舵伺服器移動的方向是否正確，若不正確請更改遙控器上的尾舵伺服器正逆轉方向。將GP790切換成非鎖定模式或持按GP790的"SET"鍵2秒，使尾舵伺服器保持在中立點的位置上，調整伺服舵片，盡可能使尾舵連桿與伺服擺臂呈90度，接著調整連桿長度使尾Pitch控制組置中。
5. NOR/REV陀螺儀正逆轉開關設定：提起直昇機，將機頭往左擺動，若尾舵伺服器的擺動方向與遙控器的方向舵搖桿打右舵同方向時，表示陀螺儀的動作方向設定正確，若不正確時請更改正逆轉設定。
- 設定方式：持按"SET"鍵2秒進入功能設定模式，選擇NOR/REV選項，以方向舵選擇NOR (STATUS為綠燈)或REV (STATUS為紅燈)。
- 注意：陀螺儀的正逆轉方向設定錯誤時會造成直昇機高速自旋的危險，請務必確認。
6. LIMIT尾舵伺服器行程量調整：持按"SET"鍵2秒進入功能設定模式，此時尾舵伺服器會保持在中立點的位置上，選擇LIMIT選項，接著將方向舵搖桿慢慢的往左移動，使尾控制組達到該側的最大行程限度後，將搖桿回歸中立點不動，待2秒後"STATUS"指示燈會亮紅燈閃爍，表示左側行程量已記憶；接著將尾舵搖桿向右移動至控制組最大行程限度後，再將搖桿回歸中立點不動，待2秒後"STATUS"指示燈亮紅燈閃爍，即完成左右行程量設定行程量不足時會影響陀螺儀與直昇機的性能，行程量過大易造成伺服器損壞。
- 注意：尾舵行程量設定不可低於50%，否則GP790將不予記憶，若發生行程量設定後，尾控制組仍會超過最大行程，請將尾伺服擺臂的球頭向內移動，避免行程不足影響陀螺儀性能。
7. 感度調整：一般具有陀螺儀感度設定功能的遙控器，可直接進入GYRO功能選項進行感度值的設定，設定值50%則陀螺儀的感度為0，設定值50%~100%，則陀螺儀感度值為鎖定狀態的0~100%；設定值50%~0%，則陀螺儀感度值為非鎖定狀態的0~100%。感度值的大小會隨著伺服器與直昇機的不同而有所差異，一般而言，在不產生追蹤現象(直昇機尾部出現左右搖擺的情況)的前提下感度值愈高愈好，所以只能透過實際飛行的狀況來進行調整。進入遙控器感度設定的選項，剛開始停懸時建議先設定在65%左右，Idle up飛行時設定在60%左右，之後再依實際飛行的狀態再行修正，如果沒有追蹤現象發生時可再調整高感度，若發生追蹤現象時，則調低感度。
- ※註：鎖定感度值為0~100%的遙控器，如Futaba，建議設定在20%左右；鎖定感度值為50~100%的遙控器，如JR、HITEC，建議感度值設定在65%左右。
8. 直昇機模式與DELAY控制延遲量調整，此設定結合兩項功能：
- (1) GP790支援小型/迷你型室內電直，請依您直昇機的類型選擇適合的模式，如：T-REX 250/450請選擇小型/迷你型模式(設定時"STATUS"指示燈為紅色)；T-REX500/600/700請選中大型直昇機模式(設定時"STATUS"指示燈為綠色)
- (2) 使用速度較慢的尾舵伺服器較容易產生追蹤現象，當直昇機停懸時，打方向舵使直昇機快速自轉，當方向舵回到中立點使直昇機停止自轉時，此時若發生追蹤現象，請增加控制延遲的設定量，一般而言在不產生追蹤現象的原則下控制延遲的設定量愈小愈好，否則尾舵的動作會變得遲緩。若使用高速型數位伺服器，請將控制延遲的設定量調整至最小(無延遲)。
- 設定方式：持按"SET"鍵2秒進入功能設定模式，選擇至DELAY選項，以方向舵搖桿選擇小型/迷你型電直如T-REX 250/450 (STATUS為紅燈)，或中大型直昇機如T-REX500/600/700 (STATUS為綠燈)，若要同時設定DELAY控制量時，則利用方向舵搖桿的位置來設定，搖桿由中立點推至"DELAY"燈開始閃爍時為0%，推至最大行程時控制量為100%，將搖桿推至所需的延遲量時保持不動，並按下"SET"鍵確認，即可同時設定直昇機模式與延遲量。

**PLEASE PRACTICE SIMULATION FLIGHT BEFORE REAL FLYING 飛行前請事先熟練模擬飛行**

Do a simulation flight until you familiarize your fingers with the movements of the rudders, and keep practicing until the fingers move naturally.

1. Place the helicopter in a clear open field ( Make sure the power OFF ) and the tail of helicopter point to yourself.
2. Practice to operate the throttle stick (as below illustration) and repeat practicing "Throttle high/low", "Aileron left/right", "Rudder left/right", and "Elevator up/down".
3. The simulation flight practice is very important, please keep practicing until the fingers move naturally when you hear operation orders being call out.
4. Another safe and effective practice method is to use the transmitter flying on the computer through simulator software sold on the market.

在還沒瞭解直昇機各動作的操控方式前，嚴禁通電飛行，請先進行模擬飛行的練習，並不斷的重複，直到手指可熟練的控制各個動作及方向。

1. 將直昇機放在空曠的地方(確認電源為關閉)，並將直昇機的機尾對準自己。
2. 練習操作遙控器的各搖桿(各動作的操作方式如下圖)，並反覆練習油門高/低、副翼左/右、升降舵前/後及方向舵左/右操作方式。
3. 模擬飛行的練習相當重要，請重複練習直到不需思索，手指能自然隨著喊出的指令移動控制。
4. 另外一種最有效、最安全的練習方式，就是透過市面販售的模擬軟體，以遙控器在電腦上模擬飛行，熟悉各種方向的操控。

Mode 1	Mode 2	Illustration 圖示
<p>Aileron 副翼</p>		
<p>Elevator 升降/前後</p>		
<p>Throttle 油門</p>		
<p>Rudder 方向</p>		

## FLIGHT ADJUSTMENT AND NOTICE FOR BEGINNERS 初學飛行調整與注意



- ⊙ Check if the screws are firmly tightened.
- ⊙ Check if the transmitter and receivers are fully charged.
- ⊙ 再次確認→螺絲是否鎖固?
- ⊙ 發射器和接收器電池是否足夠。



If there are other radio control aircraft at the field, make sure to check their frequencies and tell them what frequency you are using. Frequency interference can cause your model, or other models to crash and increase the risk of danger.  
假使飛行場有其他遙控飛機，請確認他們的頻率，並告知他們你正在使用的頻率，相同的頻率會造成干擾導致失控和大大地增加風險。

- ★ When arriving at the flying field.
- ★ 當抵達飛行場

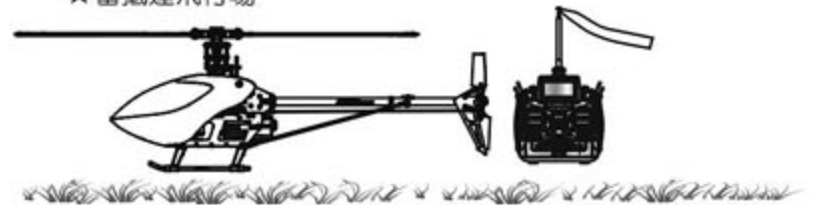

## STARTING AND STOPPING THE MOTOR 啟動和停止馬達



First check to make sure no one else is operating on the same frequency. Then place the throttle stick at lowest position and turn on the transmitter.

首先確認附近沒有其他相同頻率的使用，然後打開發射器將油門搖桿推到低點。

- ★ Check the movement.
- ★ 動作確認



**ON! Step1**  
First turn on the transmitter.  
先開啓發射器



Check if the throttle stick is set at the lowest position.  
確認油門搖桿是在最低的位置。

- ⊙ Are the rudders moving according to the controls?
- ⊙ Follow the transmitter's instruction manual to do a range test.
- ⊙ 方向舵是否隨著控制方向移動?
- ⊙ 根據發射器說明書進行距離測試。



**ON! Step2**  
Connect to the helicopter power  
接上直昇機電源



**OFF! Step3**  
Reverse the above orders to turn off.  
關閉電源時請依上述操作動作反執行。

## Main rotor adjustments 主旋翼雙槳平衡調整



**Tracking adjustment is very dangerous, so please keep away from the helicopter at a distance of at least 5m.**  
調整軌跡非常危險，請於距離飛機最少5公尺的距離。

1. Before adjusting, apply a red piece of tape on one blade, or paint a red stripe with a marker or paint to identify on blade.
2. Raise the throttle stick slowly and stop just before the helicopter lifts-off ground. Look at the spinning blades from the side of the helicopter.
3. Look at the path of the rotor carefully. If the two blades rotate in the same path, it does not need to adjustment. If one blade is higher or lower than the other blade, adjust the tracking immediately.
4. Linkage rod (C): Slight pitch trim.

1. 調整前先在其中一支主旋翼的翼端，貼上有顏色的貼紙或畫上顏色記號，方便雙槳調整辨識。
2. 慢慢的推起油門搖桿到高點並且停止，在飛機離開地面前，從飛機側邊觀察主旋翼轉動。
3. 仔細觀察旋翼軌跡(假如兩支旋翼移動都是相同軌跡，則不需要調整;可是如果一支旋翼較高或較低產生“雙槳”的情形時，則必須立刻調整軌跡)。
4. 連桿(C)為螺距微調調整。

- A. When rotating, the blade with higher path means the pitch too big. Please shorten pitch linkage rod (C) for regular trim.**  
**B. When rotating, the blade with lower path means the pitch too small. Please lengthen pitch linkage rod (C) for regular trim.**

- A. 旋翼轉動時較高軌跡的主旋翼表示螺距(PITCH)過大，請調短連桿(C)修正。  
B. 旋翼轉動時較低軌跡的主旋翼表示螺距(PITCH)過小，請調長連桿(C)修正。



**Incorrect tracking may cause vibrations. Please repeat adjusting the tracking to make sure the rotor is correctly aligned. After tracking adjustment, please check the pitch angle is approx. +5~6° when hovering.**

不正確的旋翼軌跡會導致震動，請不斷重複調整軌跡，使旋翼軌跡精準正確。  
在調整軌跡後，確認一下Pitch角度在停旋時應為大約+5-6°。

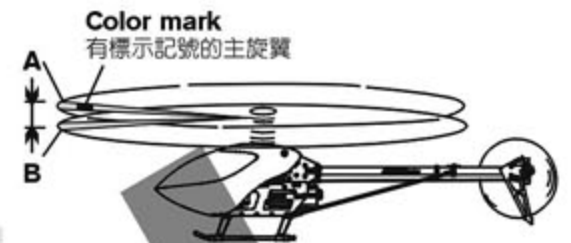

## FLIGHT ADJUSTMENT AND NOTICE FOR BEGINNERS 初學飛行調整與注意



- ◎ Make sure that no one or obstructions in the vicinity.
- ◎ You must first practice hovering for flying safety. This is a basic flight action. (Hovering means keeping the helicopter in mid air in a fixed position)
- ◎ 確認鄰近地區沒有人和障礙物。
- ◎ 為了飛行安全，你必須先練習停旋，這是飛行動作的基礎(停旋:直昇機滯留空中並保持固定位置)。
- ◎ Please stand approximately 5m diagonally behind the helicopter.
- ◎ 練習時，請站在直昇機後方5公尺。

Beginner may install a training landing gear to avoid any crash caused by offset effect while landing.  
必要時初學者可以在腳架下方安裝練習架，可避免降落時因重心偏移導致主旋翼或直昇機損毀。

## STEP 1 THROTTLE CONTROL PRACTICE 油門控制練習

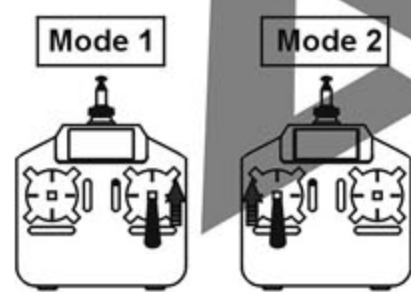

- ◎ When the helicopter begins to lift-off the ground, slowly reduce the throttle to bring the helicopter back down. Keep practicing this action until you control the throttle smoothly.
- ◎ 當直昇機開始離地時，慢慢降低油門將飛機降下。持續練習飛機從地面上升和下降直到你覺得油門控制很順。

## STEP 2 AILERON AND ELEVATOR CONTROL PRACTICE 副翼和升降控制練習

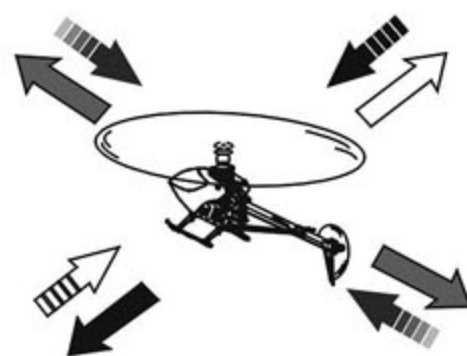
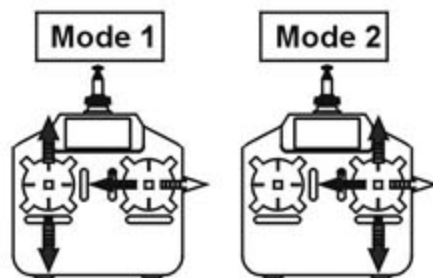

1. Raise the throttle stick slowly.
  2. Move the helicopter in any direction back, forward, left and right, slowly move the aileron and elevator sticks in the opposite direction to fly back to its original position.
1. 慢慢升起油門搖桿。  
2. 使直昇機依指示:移動向後/向前/向左/向右，慢慢的方向移動副翼和升降搖桿並將直昇機開回到原來位置。



- ◎ If the nose of the helicopter moves, please lower the throttle stick and land the helicopter. Then move your position diagonally behind the helicopter 5m and continue practicing.
- ◎ If the helicopter flies too far away from you, please land the helicopter and move your position behind 5m and continue practicing.
- ◎ 當直昇機機頭偏移時，請降低油門並且降落，然後移動自己的位置到直昇機的正後方5公尺再繼續練習。
- ◎ 假如直昇機飛離你太遠，請先降落直昇機，並到直昇機後5公尺再繼續練習。

### STEP 3 RUDDER CONTROL PRACTICING 方向舵操作練習

1. Slowly raise the throttle stick.
  2. Move the nose of the helicopter to right or left, and then slowly move the rudder stick in the opposite direction to fly back to its original position.
1. 慢慢升起油門搖桿。  
2. 將直昇機機頭移動左或右，然後慢慢反向移動方向舵搖桿並將直昇機飛回原本位置。

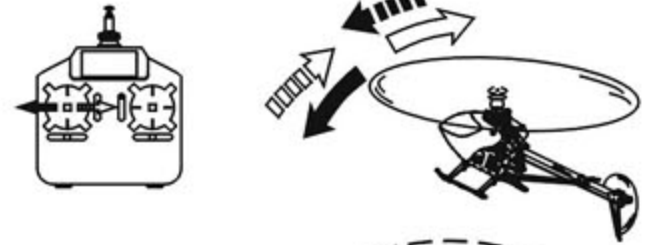

### STEP 4

After you are familiar with all actions from Step1 to 3, draw a circle on the ground and practice within the circle to increase your accuracy.

- 當你覺得 step1-3 動作熟悉了，在地上畫圈並在這個圈圈的範圍內練習飛行，以增加你操控的準確度。
- ◎ You can draw a smaller circle when you get more familiar with the actions.
  - ◎ 當你更加習慣操作動作，你可以畫更小的圈。



### STEP 5 DIRECTION CHANGE AND HOVERING PRACTICE 改變直昇機方向和練習停旋

After you are familiar with Step1 to 4, stand at side of the helicopter and continue practicing Step1 to 4. Then repeat the Step1 to 4 by standing in front of the helicopter.

當你覺得step1-4動作熟悉了，站在面對直昇機側邊並繼續練習step1-4。之後，站在直昇機機頭前方重複步驟練習。

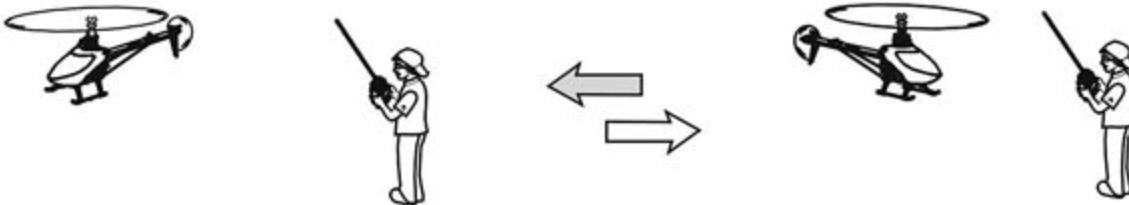

### ADJUSTMENT OF EACH TRIM 飛行動作微調

Slowly raise the throttle stick and just as the helicopter lift-off the ground, you can use the trim to correct the action if the helicopter leans in a different direction.

慢慢升起油門搖桿，當直昇機剛剛離開地面時，若直昇機傾向不同方向，可使用微調修正動作。

**1. Adjustment of elevator trim 調整升降舵微調**  
Just before the helicopter lift-off, the nose lean forward/backward...

When leans forward, adjust the trim down.  
When leans backward, adjust the trim up.

在直昇機正要起飛時，機頭朝前/後方向偏移...  
向前偏移時，微調向下調整。  
向後偏移時，微調向上調整。

**2. Adjustment of Aileron trim 調整副翼微調**  
Just before the helicopter lift-off, the body lean left/right...

When leans right, adjust the trim to left side.  
When leans left, adjust the trim to right side.

在直昇機正要起飛時，機身朝左/右方向偏移...  
向右偏移時，微調向左調整。  
向左偏移時，微調向右調整。

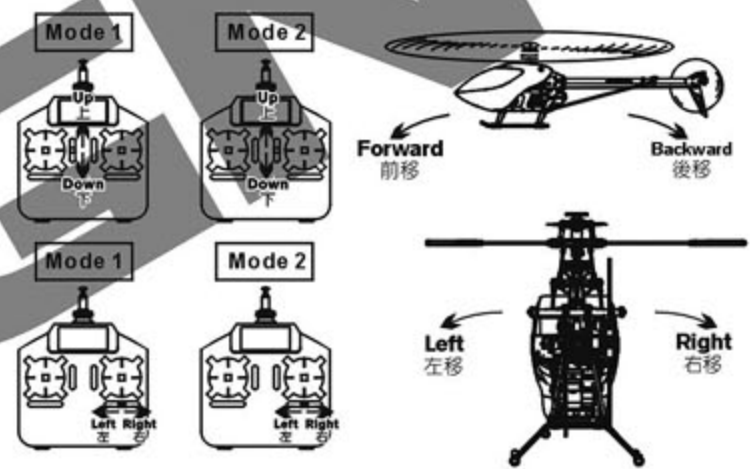

### TROUBLE SHOOTING DURING FLIGHT 如何排除飛行中的狀況

	Situation 狀況	Cause 原因	Way to deal 對策
Blade Tracking 雙槳平衡	Out of tracking 雙槳	Adjustment of pitch rod has not been done. PITCH連桿長度調整不平均	Adjust the length of linkage rod(C) → Slight trim 調整連桿(C)長度
During Hovering 停懸	Low rotation of the rotor 主旋翼轉速偏低	★ Pitch of main blade is high. ★ 主旋翼的PITCH偏高 ★ Throttle curve is too low during hovering. ★ 停懸點油門曲線過低	★ Lower the pitch about 5~6 during hovering (The rotation should be about 3,300~3,500rpm during hovering). ★ 調低Pitch停懸Pitch約5-6 (停懸時主旋翼需為約3,300~3,500rpm) ★ Heighten the throttle curve during hovering. ★ 調高停懸點油門曲線
	High rotation of the rotor 主旋翼轉速偏高	★ Pitch of main blade is low. ★ 主旋翼的PITCH偏低 ★ Throttle curve is too high during hovering. ★ 停懸點油門曲線過高	★ Adjust the pitch rod(C) (The rotation should be about 3,300~3,500rpm during hovering). ★ 調整連桿(C) (停懸時主旋翼需為約3,300~3,500RPM) ★ Lower the throttle curve during hovering. ★ 調低停懸點油門曲線
Sensitivity of the gyro 陀螺儀敏感度	The tail leans to one side during hovering, or when trim the rudder and return to the neutral, the tail lags and cannot stay in a control position. 停懸時尾翼向某一邊偏移，或撥動方向舵並回復到中立點時，尾翼產生延遲，無法停頓在所控制位置上。	★ Failure setting of tail neutral point. ★ 尾中立點設定不當 ★ The sensitivity of the gyro is low. ★ 陀螺儀敏感度偏低	★ Reset tail neutral point. ★ 重設尾中立點 ★ Increase the sensitivity. ★ 增加敏感度
	The tail wags left and right during flight at hovering or full speed. 停懸或全油門時尾翼左右來回搖擺。	The sensitivity of the gyro is high. 陀螺儀敏感度偏高	Decrease the sensitivity. 降低敏感度

※ If the problem is still there even after tried above, stop flying and contact with your seller.  
※ 在做完以上調整後，仍然無法改善情況時，應立即停止飛行並連絡您的經銷商。

www.align.com.

www.a

www.align.com

www.align

www.align.com.tw

www.align.

www.align.com.tw

www.align.com.t

# ALIGN

## Specifications & Equipment/規格配備:

Length/機身長: 431 mm

Height/機身高: 162mm

Main Blade Length/主旋翼長: 205mm

Main Rotor Diameter/主旋翼直徑: 460mm

Tail Rotor Diameter/尾旋翼直徑: 108mm

Motor Pinion Gear/馬達主齒: 15T

Main Drive Gear/傳動主齒: 120T

Tail Drive Gear/尾翼傳動齒: 28T

Drive Gear Ratio/齒輪傳動比: 1:8:4.28

Weight(Without Power System)/空機重: 150g

Flying Weight/全配重: Approx. 340g

