

MICRO HELICOPTER **T-REX 100S Combo**

ALIGN

INSTRUCTION MANUAL

使用說明書

KX022003T

T-REX In The House!



Contents	
1	INTRODUCTION 前言
1~2	SAFETY NOTES 安全注意事項
3	PACKAGE ILLUSTRATION 包裝說明
3	STANDARD EQUIPMENT 標準配件
3	NOMENCLATURE 直昇機各部位名稱
4	3 STEPS FOR HELICOPTER ASSEMBLY 直升機組裝三步驟
5	NOMENCLATURE 遙控器各部位名稱
6	TRANSMITTER BATTERY INSTALLATION 遙控器電池安裝
6	CHARGING BATTERIES 電池的充電
7~8	SWITCHING BETWEEN MODE1/MODE2/ MODE3 ON TRANSMITTER 遙控器MODE1/MODE2/MODE3 的切換
8	FLIGHT SIMULATOR USAGE INSTRUCTION 飛行模擬器使用說明
9	BINDING OF RADIO TRANSMITTER AND RECEIVER 遙控器與接收器的對頻
9~11	USAGE INSTRUCTIONS AND CHECK LISTS 開機步驟與飛行前檢查
12~13	FLIGHT ADJUSTMENT AND SETTING 飛行動作調整與設定
14~15	TROUBLE SHOOTING DURING FLIGHT 如何排除飛行中的狀況
15~16	PART LIST 各部零件名稱

Thank you for buying ALIGN products. The **T-REX 100S** is the latest technology in Rotary RC models. Please read this manual carefully before assembling and flying the new **T-REX 100S** helicopter. We recommend that you keep this manual for future reference regarding tuning and maintenance.

承蒙閣下選用亞拓遙控世界系列產品，謹表謝意。進入遙控世界之前必須告訴您許多相關的知識與注意事項，以確保您能夠在學習的過程中較得心應手。在開始操作之前，請務必詳閱本說明書，相信一定能夠給您帶來相當大的幫助，也請您妥善保管這本說明書，以作為日後參考。

Thank you for your purchase of this Align product. T-REX 100S is a micro RC helicopter that is designed for smaller flight space. For a pleasant experience with your T-REX 100S, please read through this manual carefully prior to helicopter assembly and operation. Keep this manual handy as a future reference for adjustment and maintenance.

感謝您選購亞拓產品！T-REX 100S 是一台專為較小空間所設計的遙控直昇機，為了讓您更方便、更容易的使用 T-REX 100S，請您仔細閱讀完此說明書後，再進行組裝及操作這台直昇機，同時請您妥善的保存這本說明書，作為日後調整及維修的參考。

No matter when and where, Align T-REX series RC helicopter can always satisfy your flight desire.

亞拓 T-REX 系列直昇機，機種最齊全，不論何時何地，不管晴天雨天，都可以滿足您對飛行的渴望。

WARNING LABEL LEGEND 標誌代表涵義

<p>WARNING 警告</p>	<p>Mishandling due to failure to follow these instructions may result in damage or injury. 因為疏忽這些操作說明，而使用錯誤可能造成財產損失或嚴重傷害。</p>
<p>CAUTION 注意</p>	<p>Mishandling due to failure to follow these instructions may result in danger. 因為疏忽這些操作說明，而使用錯誤可能造成危險。</p>
<p>FORBIDDEN 禁止</p>	<p>Do not attempt under any circumstances. 在任何禁止的環境下，請勿嘗試操作。</p>

IMPORTANT NOTES 重要聲明

T-Rex 100S is a sophisticated hobby product and not a toy. Although small, it still poses certain risk factors that should not be over looked. Please follow safety and operation recommendations to ensure correct operation of this helicopter. The use of this helicopter beyond its intended purposes and disassembly may cause unforeseen danger, and should be avoided.

T-REX 100S並非玩具，雖然是微型的遙控直升機，但是仍然有一定的危險性，請您依安全注意事項與操作說明來正確的使用該模型，任意的改裝拆解或使用不當以及對產品的不熟悉，都可能造成不可預期的危險或意外，請勿輕忽。

Manufacturer and dealer assume no liability for accidental damages caused by abnormal wear of parts, improper assembly, or operation in unsafe manners. This product is intended for use by age 15 years or older.

Please ensure the product is operated under safe environment.

注意！任何遙控直升機的使用，製造商或經銷商是無法對使用者於零件使用的損耗異常、組裝不當或不安全的環境下操作所發生之意外負任何責任，**本產品適用年齡15歲以上**，請確保在安全無虞的環境下操作。產品售出後本公司將不負責因不當操作、拆卸、改裝所引起的財產損失與人身傷害。

We recommend that you seek the assistance of an experienced pilot before attempting to fly our products for the first time. A local expert is the best way to properly assemble, setup, and fly your model for the first time.

The T-REX 100S requires a certain degree of skill to operate, and is an item subject to normal wear and tear. Any damage or dissatisfaction as a result of accidents or modifications are not covered by any warranty and cannot be returned for repair or replacement. Please contact our distributors for free technical consultation and parts at discounted rates when you experience problems during operation or maintenance.

模型商品屬於需高操作技術且為消耗性之商品，如經拆裝使用後，會造成不等情況零件損耗，任何使用情況所造成商品不良或不滿意，將無法於保固條件內更換新品或退貨，如遇有使用操作維修問題，本公司全省分公司或代理商將提供技術指導、特價零件供應服務。



Fly only in safe areas, away from other people. Do not operate R/C aircraft within the vicinity of crowds of people. R/C aircraft are prone to accidents, failures, and crashes due to a variety of reasons including, lack of maintenance, pilot error, and radio interference. Pilots are responsible for their actions and damage or injury occurred during the operation or as of a result of R/C aircraft models.

遙控模型飛機、直昇機屬高危險性商品，飛行時務必遠離人群，人為組裝不當或機件損壞、電子控制設備不良，以及操控上的不熟悉、都有可能導致飛行失控損傷等不可預期的意外，請飛行者務必注意飛行安全，並需了解自負疏忽所造成任何意外之責任。



LOCATE AN APPROPRIATE LOCATION 室內專用機，請遠離障礙物

This product is for indoor use and only fly at the place without wind. Before flying, choose a legal flying field consisting of flat, smooth ground without obstacles, pets, and crowds. To ensure the safety of yourself, others and properties, do not fly in the vicinity of heat, high voltage wires, or power sources to avoid accidental fires and electrical shocks.

本產品為適合室內、無風環境飛行的電動直昇機，飛行時請妥善選擇無障礙物的室內場地，並與人群或寵物等保持適當距離，切勿於不安全的環境下操作，如熱源、電線、電源等等，以免直昇機碰撞、迫降、糾纏而引發火災、電擊等危險，造成生命財產損失。

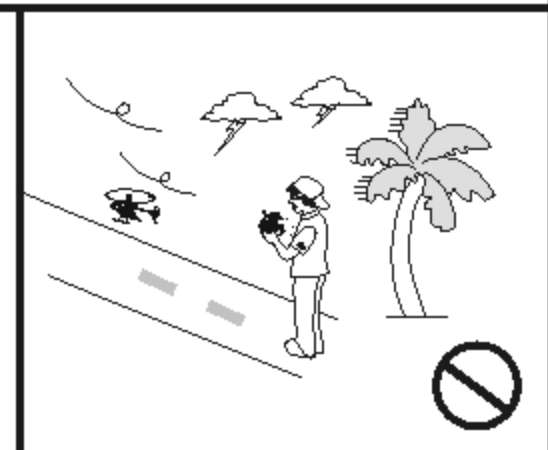

<p>FORBIDDEN 禁止 PREVENT MOISTURE 遠離潮濕環境</p> <p>R/C models are composed of many precision electrical components. It is critical to keep the model and associated equipment away from moisture and other contaminants. The introduction or exposure to water or moisture in any form can cause the model to malfunction resulting in malfunction, or a crash. Do not operate or expose to rain or moisture.</p> <p>直昇機內部也是由許多精密的電子零組件組成，所以必須絕對的防止潮濕或水氣，避免在浴室或雨天時使用，防止水氣進入機身內部而導致機件及電子零件故障而引發不可預期的意外！</p>	
<p>FORBIDDEN 禁止 PROPER OPERATION 勿不當使用本產品</p> <p>To avoid potential fire hazard from batteries, please do not short, reverse polarity, or puncture batteries. Battery charging must be done under supervision at all times, and at location out of reach by children. Double check the four AA batteries are rechargeable Ni-CD/Ni-MH batteries before charging. The manufacturer of this product will not be liable for accidental damages incurred by charging non-rechargeable batteries.</p>	
<p>FORBIDDEN 禁止 SAFETY NOTE FOR DRY CELL BATTERIES 乾電池使用安全</p> <p>The included AA batteries are non-rechargeable carbon-zinc batteries. Do not attempt to charge these batteries. Make sure the batteries are installed based on polarity indicated in the case and do not mix batteries of different chemistry/spec. Please take out the batteries if you are not going to use for a long time to avoid potential leakage which may damage the transmitter. Please dispose depleted batteries according to local laws and ordinances. Do not dispose improperly.</p> <p>The transmitter for the Trex 100 has AA batteries charging function. Please make sure you are using rechargeable Ni-mh batteries before charging begins. Manufacturer and dealer assume no liability for accidental damages caused by charging of non-rechargeable batteries.</p> <p>本產品所附的 4 顆 3號(AA)碳鋅電池，不可重複充電使用。安裝時請確認正負極位置，新舊電池請勿同時混用以免影響電池壽命。若長時間不使用本產品，請取出電池，以免造成電池漏液、故障。若電池有漏液狀況請勿再使用。廢棄的電池，請依照該使用國家或地區的廢棄物清理法令回收，切勿任意丟棄以免污染環境。</p> <p>本產品之遙控器具有 3號(AA) 電池充電功能，請確認遙控器上的4顆3號(AA)電池皆為可重複充電的鎳氫電池，才可對遙控器電池進行充電。使用非充電電池所造成的任何損壞與意外，本公司不負任何損害賠償責任。</p>	 <p>Non-rechargeable AA batteries 不可重複充電AA(3號)電池</p>
<p>FORBIDDEN 禁止 SAFETY NOTE ON LI-POLYMER BATTERIES 鋰聚電池使用安全</p> <p>Li-Polymer batteries poses higher operational risks compared to other battery chemistry, thus it is imperative to follow its usage instructions. Manufacturer and dealer assume no liability for accidental damages caused by improper usage.</p> <ul style="list-style-type: none"> ★Do not use charger other than the factory supplied unit to avoid potential fire and explosion. ★Do not crush, disassemble, burn, and reverse polarity. Avoid metallic materials to come into contact with battery's polarity and cause it short and never puncture batteries to avoid fire hazards. ★Battery charging must be done under supervision at all times, and at location out of reach by children. ★Please stop the use or charge of the battery should there be an unusual increase in battery temperature after use. Continue use of this battery may cause it to expand, deform, explode, or even result in fire hazards. ★Please dispose depleted batteries according to local laws and ordinances. Do not dispose improperly. <p>鋰聚電池較其他電池有更高的危險性，使用前請務必詳讀並遵照下列注意事項使用本電池，本公司將不對任何不當使用所造成的損害負責。</p> <ul style="list-style-type: none"> ★嚴禁使用原廠以外的充電器進行充電，以免發生爆炸起火的危險。 ★嚴禁撞擊、拆解、正負極反接、焚燒電池，避免金屬物品碰觸電池正負極造成短路。並請防止尖銳的物品刺穿電池，以避免電池起火的危險。 ★充電時請謹慎小心，確保在您的視線範圍內進行充電。並遠離幼童可以接觸到的地方，以免發生危險。 ★電池使用後如有發熱情況，嚴禁充電。否則會造成電池膨脹、變型、爆炸甚至起火燃燒，危害生命財產的安全。 ★廢棄的電池，請嚴格依照該使用國家或地區的廢棄物清理法令回收，以免污染環境。 	
<p>CAUTION 注意 KEEP AWAY FROM HEAT 遠離熱源</p> <p>R/C models are made of various forms of plastic. Plastic is very susceptible to damage or deformation due to extreme heat and cold climate. Make sure not to store the model near any source of heat such as an oven, or heater. It is best to store the model indoors, in a climate-controlled, room temperature environment.</p> <p>遙控飛機多半是以 PA 纖維或聚乙烯、電子商品為主要材質，因此要盡量遠離熱源、日曬，以避免因高溫而變形甚至熔毀損壞的可能。</p>	
<p>WARNING 警告 OBTAIN THE ASSISTANCE OF AN EXPERIENCED PILOT 避免獨自操控</p> <p>This product is intended for operators of age 15 years and older.</p> <p>Due to the learning curve of RC helicopters, we recommend guidance by experienced flyers. The radio transmitter features computer simulator output which can be used with commercial or free simulator software to assist with the learning process.</p> <p>本產品適用年齡15歲以上，遙控直升機在學習初期有著一定的難度，建議有經驗的人士在旁指導才可以飛行，本產品的遙控器具備電腦模擬器輸出的功能，可透過隨附的飛行模擬軟體或市售的飛行軟體練習飛行，提升熟練度。</p>	

3. PACKAGE ILLUSTRATION 包裝說明

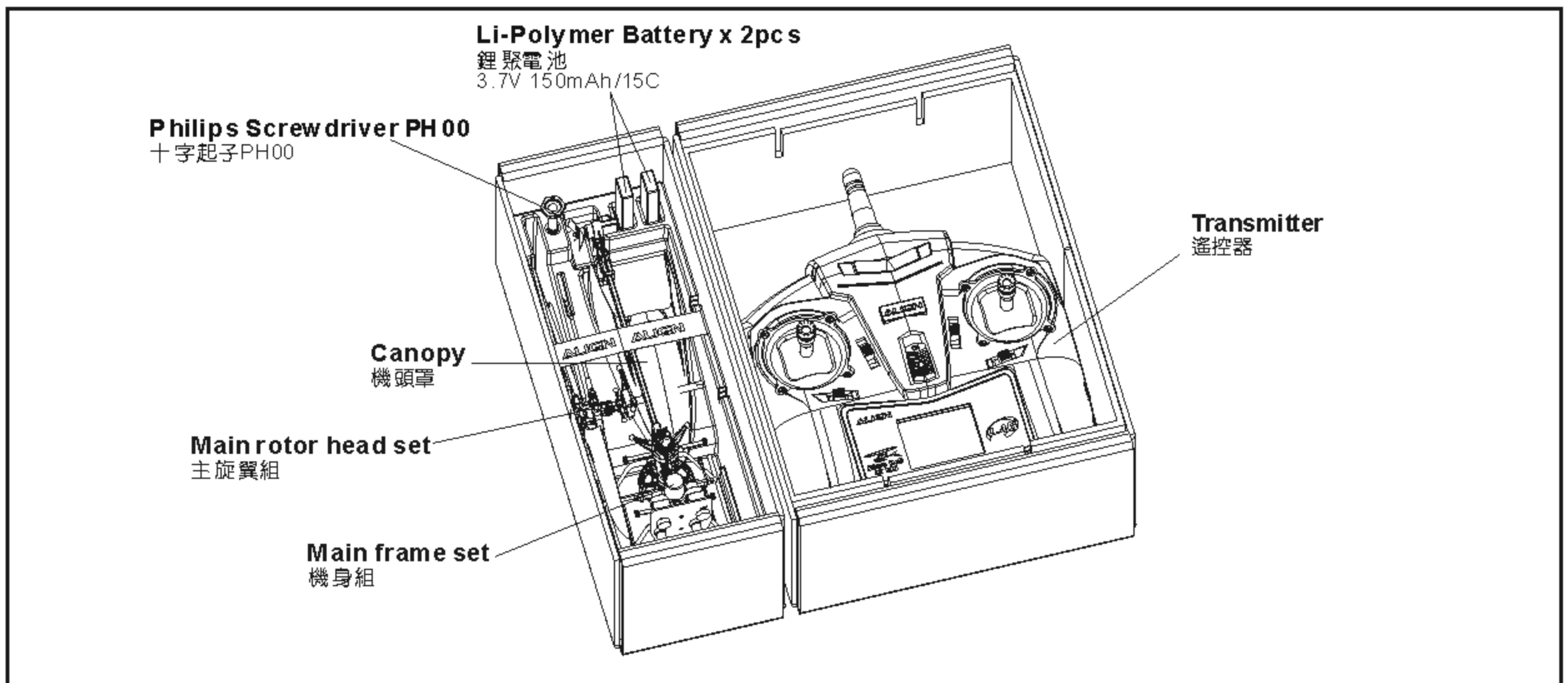

4. STANDARD EQUIPMENT 標準配件

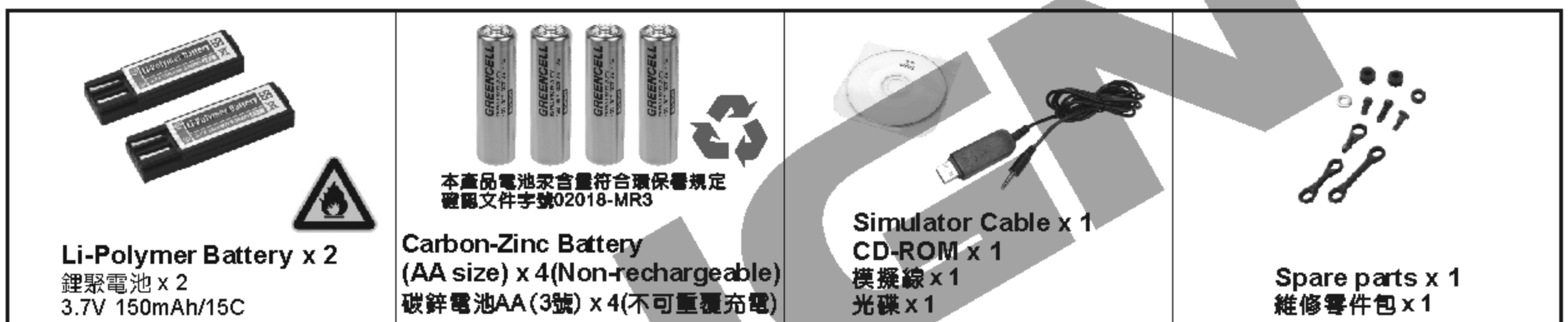

5. NOMENCLATURE 直昇機各部位名稱

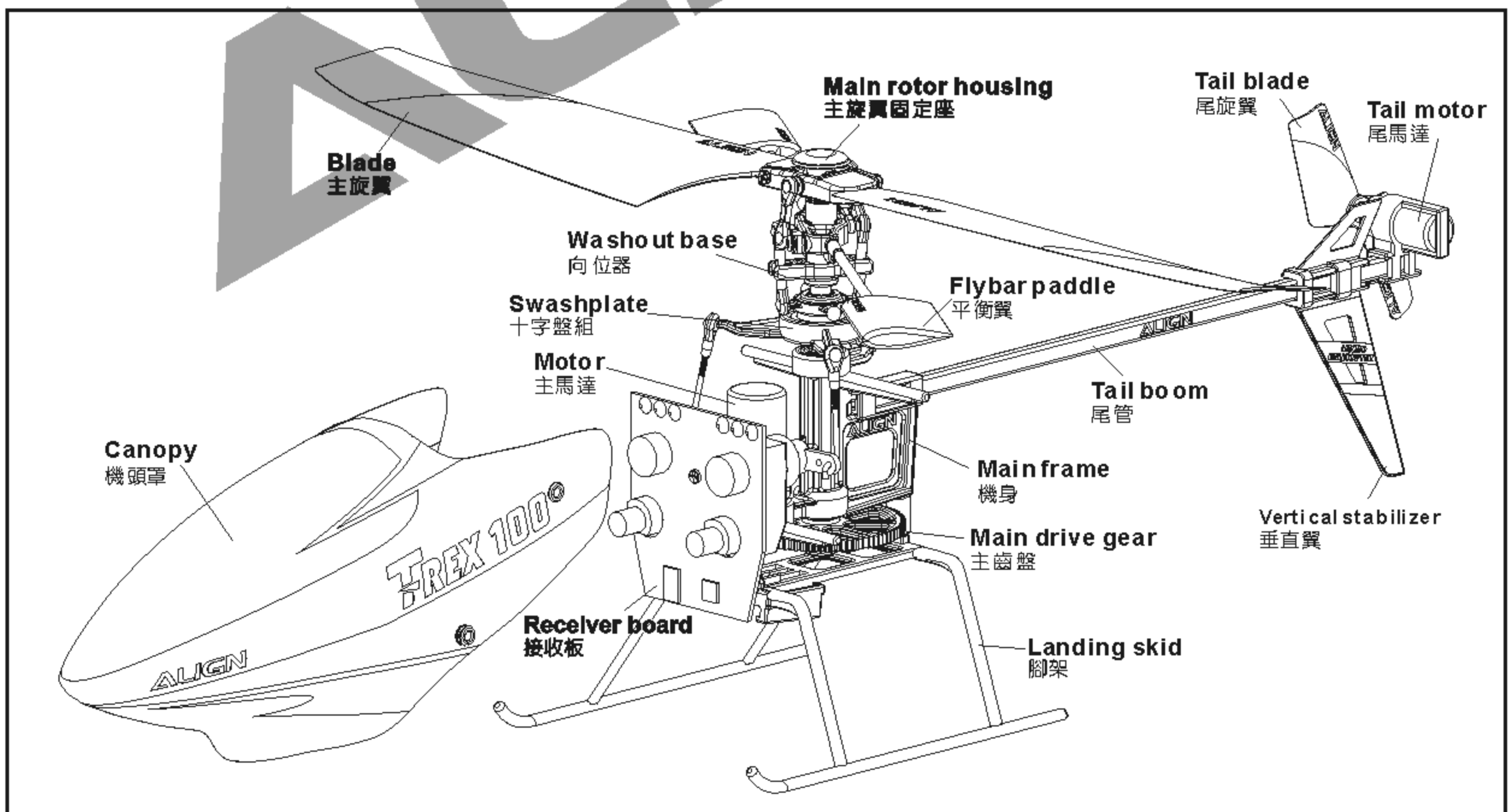

Step 1

Main rotor head set
主旋翼組

Press the main rotor assembly onto main shaft until fixed in position.
主旋翼組壓入主軸至定位。

Please release the screw and then install the main rotor set at the proper position.
請先將螺絲退出，再將主旋翼組壓入至定位。

Ball link B installation position (11.5mm)
連桿頭B組裝位置(11.5mm)

Ball link B
連桿頭B

Please install ball link B in washout base slot.
連桿頭B請組裝在向位器溝槽中。

Concave side face out
平面請朝外

Main frame set
機身組

Approx. 17mm
Approx. 15.2mm
Approx. 10.5mm

Step 2

Ensure all linkages and balls move freely without binding.
請確認所有連桿頭和球頭作動滑順不干涉。

Approx. 1mm
約1mm

Do not overtighten the collar screw and make sure the control arm is working smoothly.
軸套螺絲請勿鎖緊，確認控制臂作動順暢不干涉。

Screw
圓頭十字自攻螺絲
T1.4x2.5mm

CAUTION
注意

Please tighten with suitable force, as over tighten will cause deformation of the head block, resulting in poor concentricity.
請以適當扭力鎖緊即可，過度鎖緊會導致主旋翼固定座同心度不良。

A B

Stable flight uses inner hole (A)
穩定飛行使用內孔(A)

Nimble flight uses outer hole (B)
敏捷飛行使用外孔(B)

Step 3

CAUTION
注意

Canopy
機頭罩

CAUTION
注意

Tail rotors rotate in certain direction. When you are replacing the tail rotors, please make sure the side with ALIGN emblem faces the motor mount side.
尾旋翼旋轉有方向性，如需更換尾旋翼時，請確認ALIGN字樣朝馬達座這一側。(如圖示)

Rotate direction
旋轉方向

CAUTION
注意

Main gear is designed to fix onto main shaft without screw. When pressing main gear on to main shaft, match the flat spot on the main shaft and press all the way in to ensure it is seated all the way in.
主齒固定為無螺絲嵌入設計，當主齒壓入主軸時，請對準缺口至定位並確認主軸上下無虛位。

CAUTION
注意

Some parts are already assembled by factory, please re-check if the screws are fastened when assembling, and carefully inspect before every flight.
原廠已完成部分組裝，組立時仍需再確認螺絲是否不會鬆動，並養成每次飛行前檢查的習慣。

FORBIDDEN
禁止

Do not disassemble
禁止任意拆解

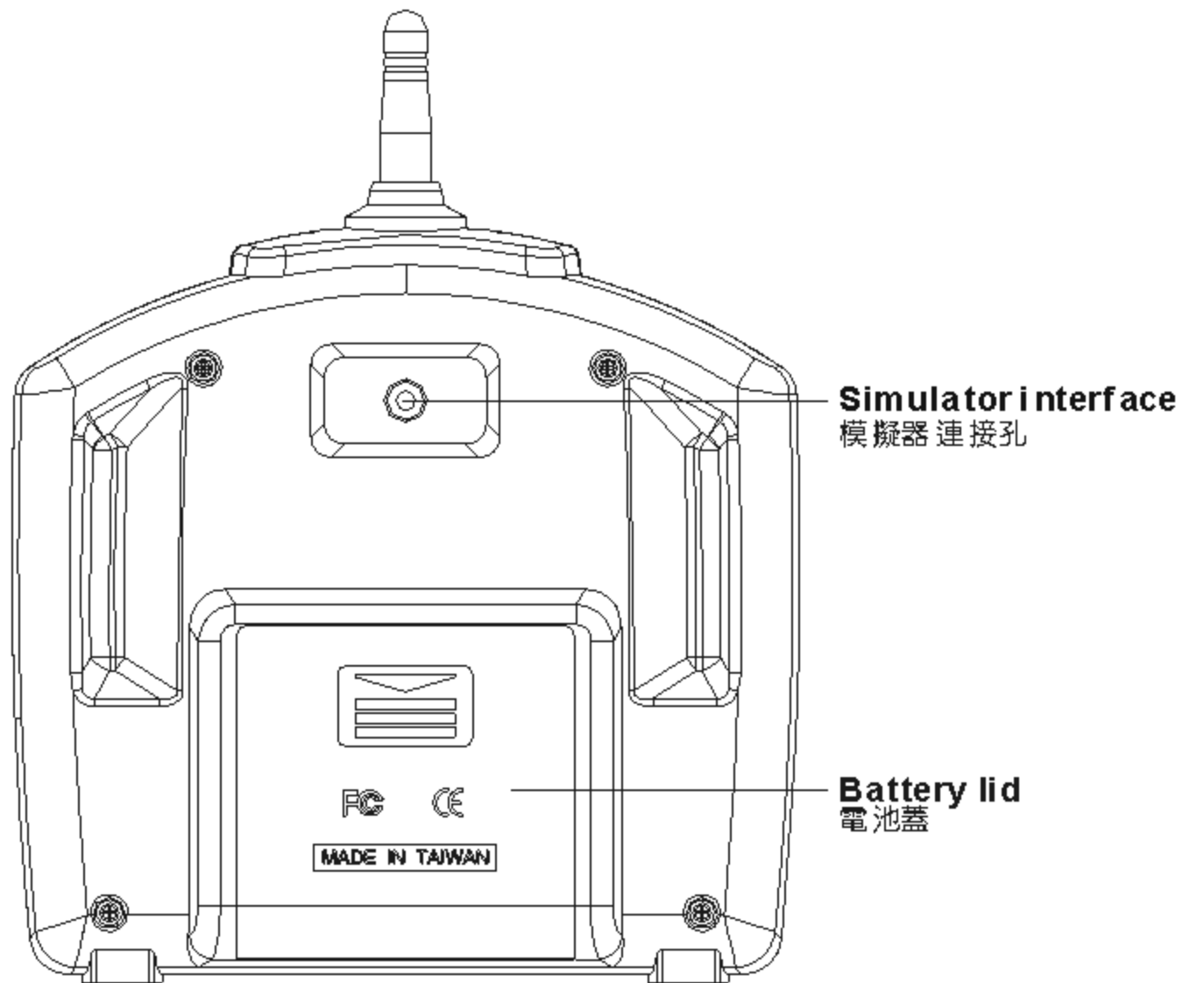
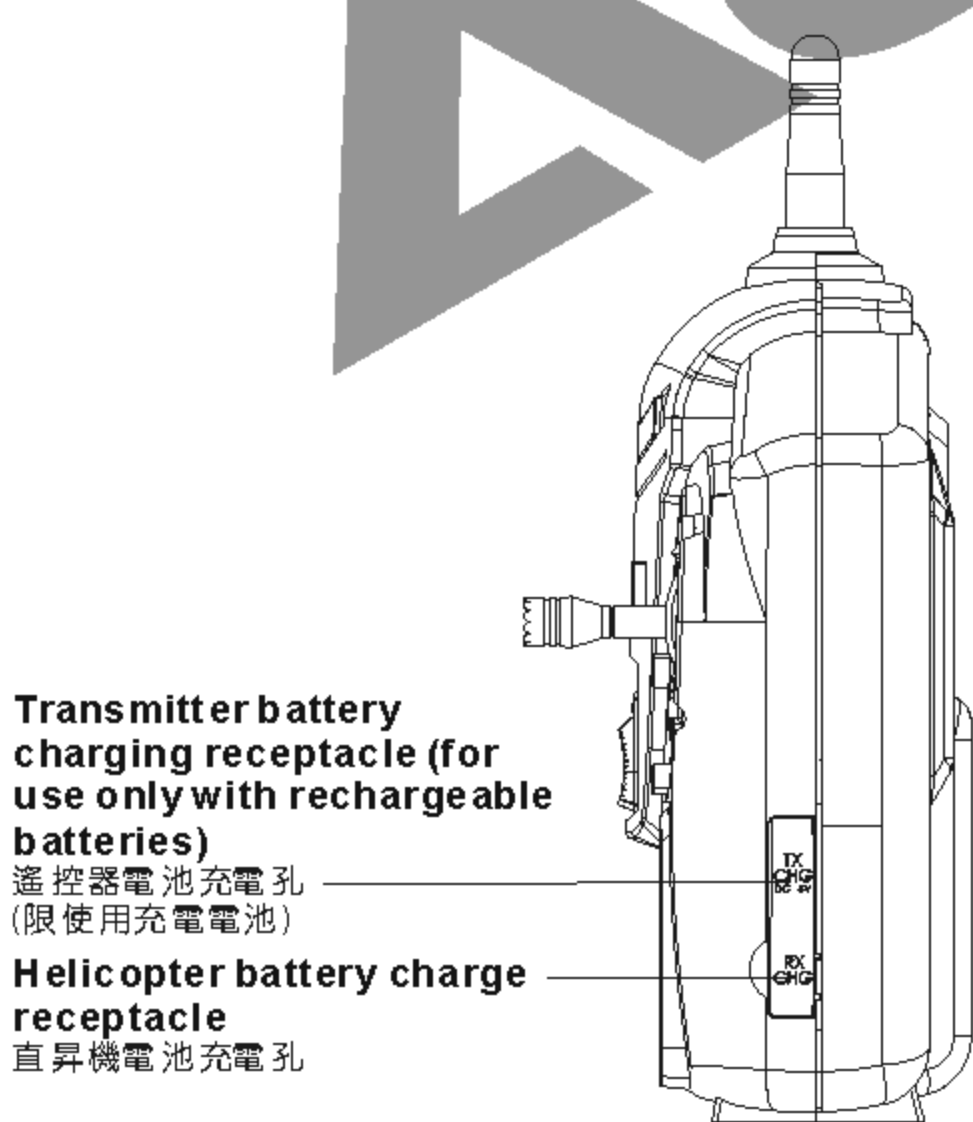
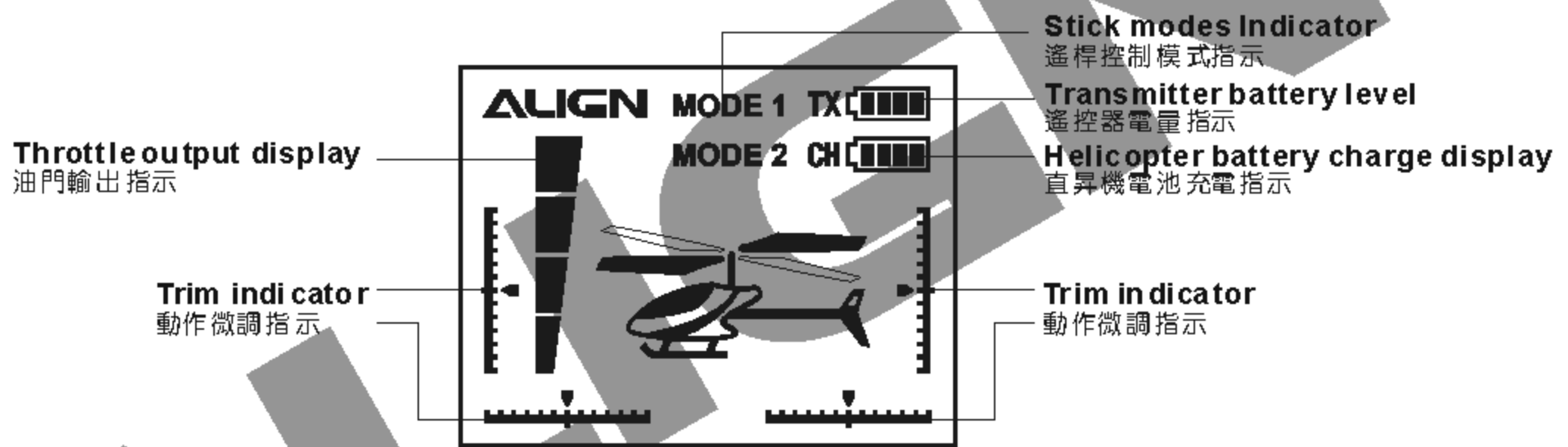
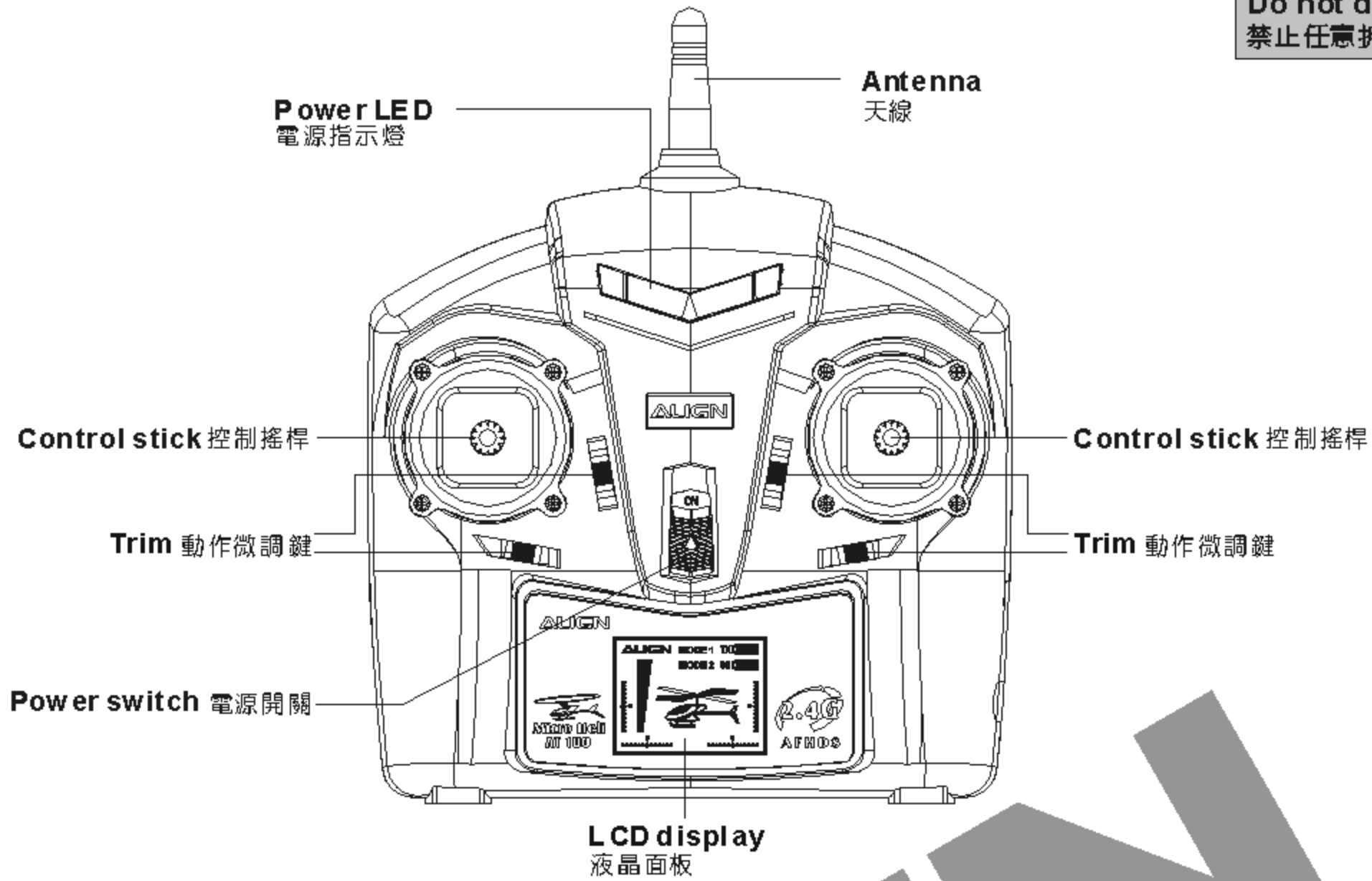

Step 1

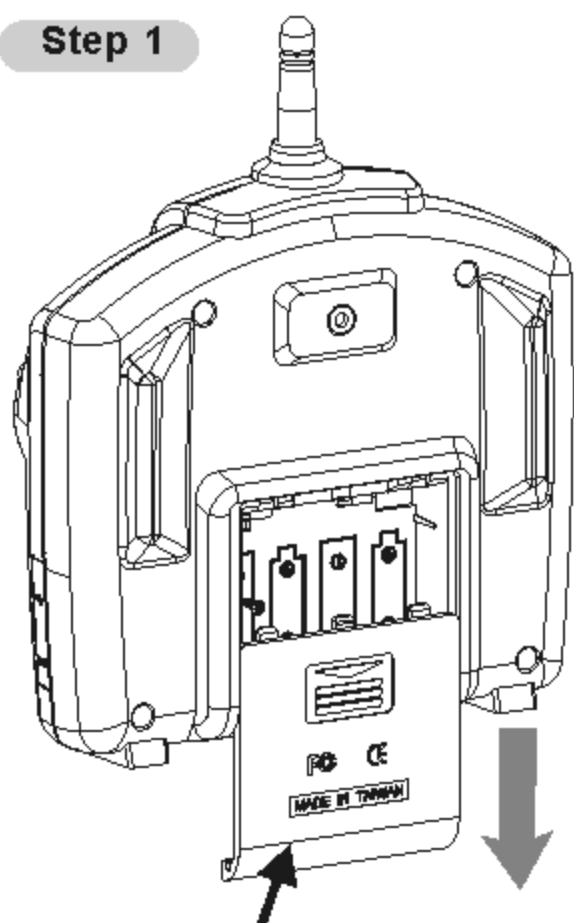

Slide the battery lid to open by following the arrow.
請依箭頭方向先將電池蓋打開。

Step 2

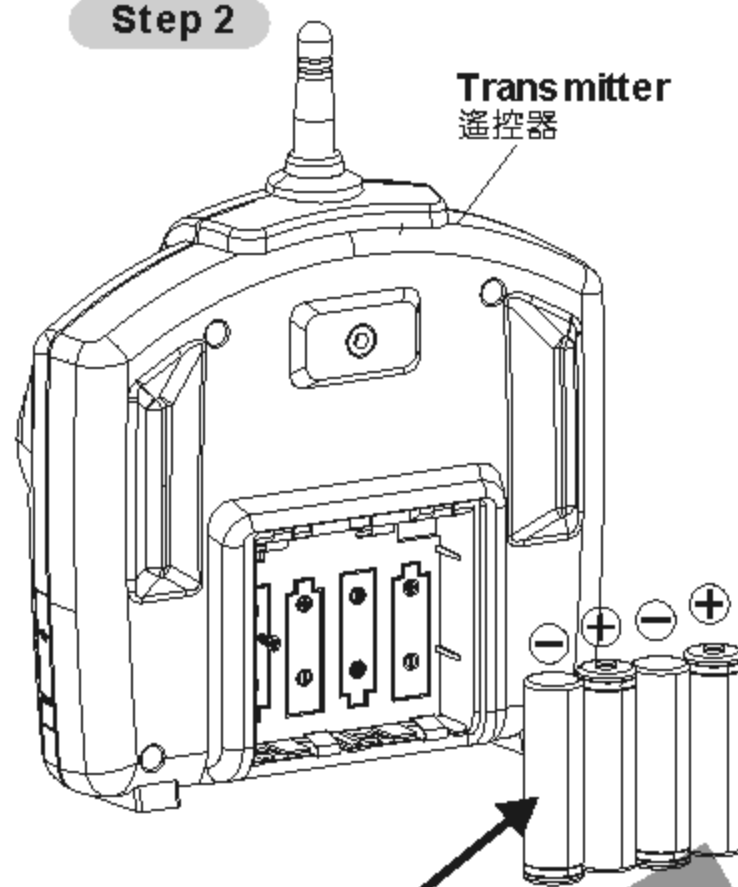

Please use 4 AA sized batteries, installed based on polarity indicate in case. No not mix batteries of different chemistry/spec.
請使用4顆3號電池(AA)，並依正負極性方向組裝。(勿混用不同規格電池)



Do not disassemble
禁止任意拆解



1. The included AA batteries are non-rechargeable carbon-zinc batteries. **Do not attempt to charge these batteries.**
2. When transmitter battery is near depletion, the LCD panel will display TX and emits an alarm, reminding you to replace batteries.
3. Please dispose depleted batteries according to local laws and ordinances. Do not dispose improperly.

1. 附贈的3號電池為一般碳鋅電池，**嚴禁對此電池進行充電。**
2. 當電池電量不足時，液晶螢幕顯示TX 且遙控器會一直鳴叫警示，此時請更換新電池。
3. 電量耗盡的廢電池，請依當地的法令回收，勿任意丟棄。

9. CHARGING BATTERIES 電池的充電

Using the charging receptacle on transmitter to charge helicopter battery 利用遙控器上的充電孔充直昇機電池

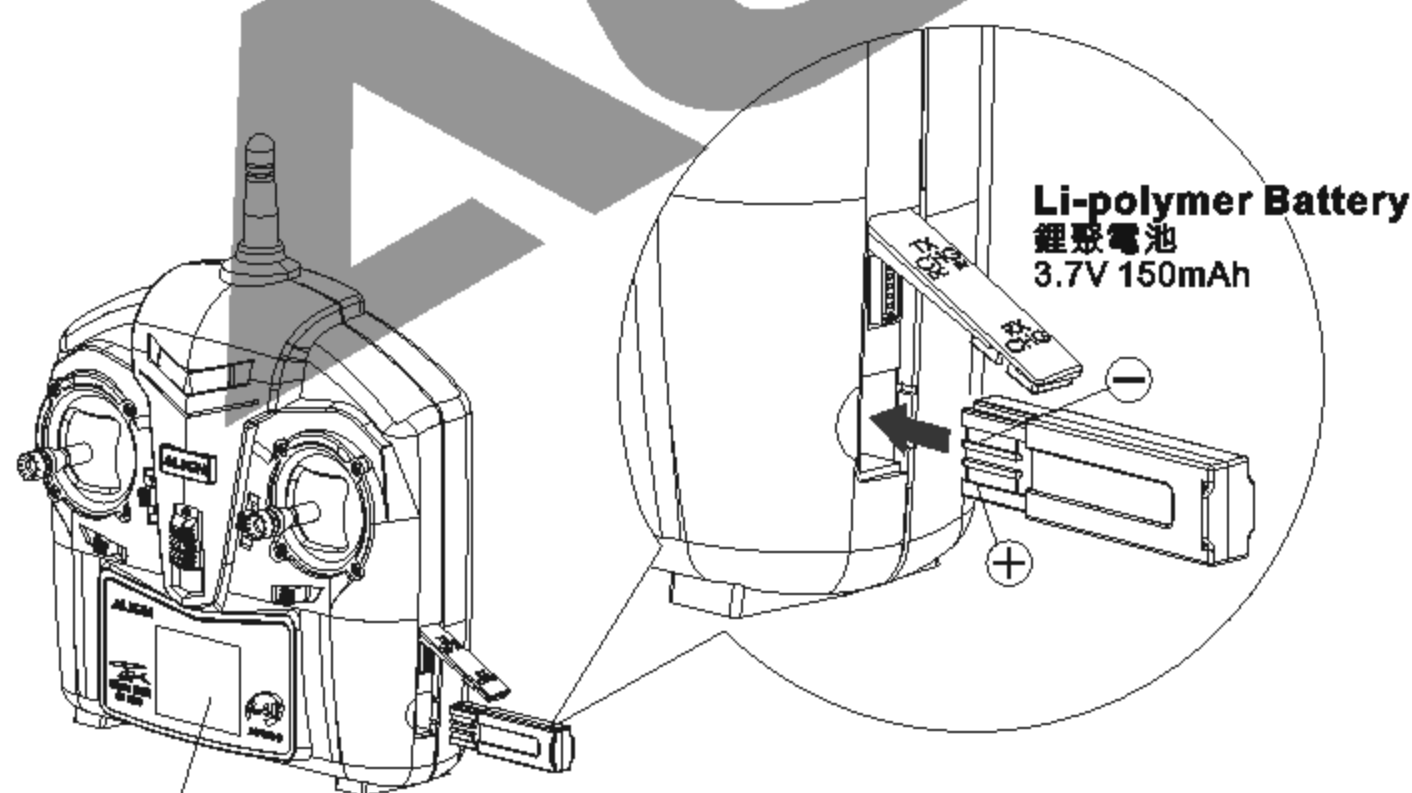

Turn on the transmitter power, and insert the helicopter lipo battery in to charging receptacle in the direction shown in diagram.

請打開遙控器電源，再將直昇機的Li-po電池依圖示的方向推入充電孔至定位。

The CH indication on radio transmitter will blink indicating charging in progress. Once the CH meter reaches 4 bars and stops blinking, the battery has finished charging.

充電時螢幕上會顯示CH 的圖示，以閃爍的方式表示正在充電中，當電池容量顯示4格且停止閃爍時，表示電池已充滿。



For safety concerns, battery charging must be done under supervision at all times.
為確保安全，充電時務必在視線範圍內進行。



If the radio transmitter emits continuous beeping sound during charging process, the 4 AA batteries in the transmitter is near depletion and needs to be replaced.

若充電過程中遙控器發出連續的鳴叫聲，表示遙控器的4顆3號電池電量不足，請更換新電池。

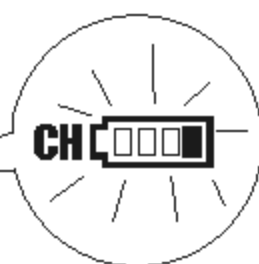
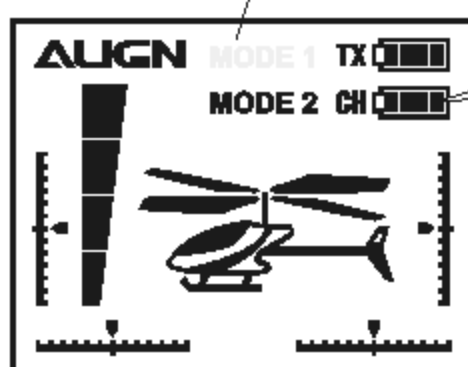

MODE 1 is commonly used in Asia where throttle stick is on the right hand side, where MODE 2 (throttle stick on left side) is more common amongst western countries. MODE 3 is same as MODE 1 with throttle stick on the right hand side but the position of AIL and RUD are reversed. Please set the transmitter MODE based on your preference.

亞洲地區大部分使用 MODE 1 的操控模式，即油門搖桿位於右手邊的位置，歐美地區則偏好 MODE 2 操控模式，即油門搖桿位於左手邊，而 MODE 3 油門搖桿與 MODE 1 同樣位於右手邊，但方向舵與副翼搖桿位置與 MODE 1 相反，請您選擇自己習慣或容易學習與操控的模式來操作直昇機。

Note: Amongst the 4 axis of the transmitter control sticks, the axis that does not spring back to center is the throttle stick.

註：搖桿的四個方向中，不會自動彈回中間位置就是控制油門的搖桿

MODE 1

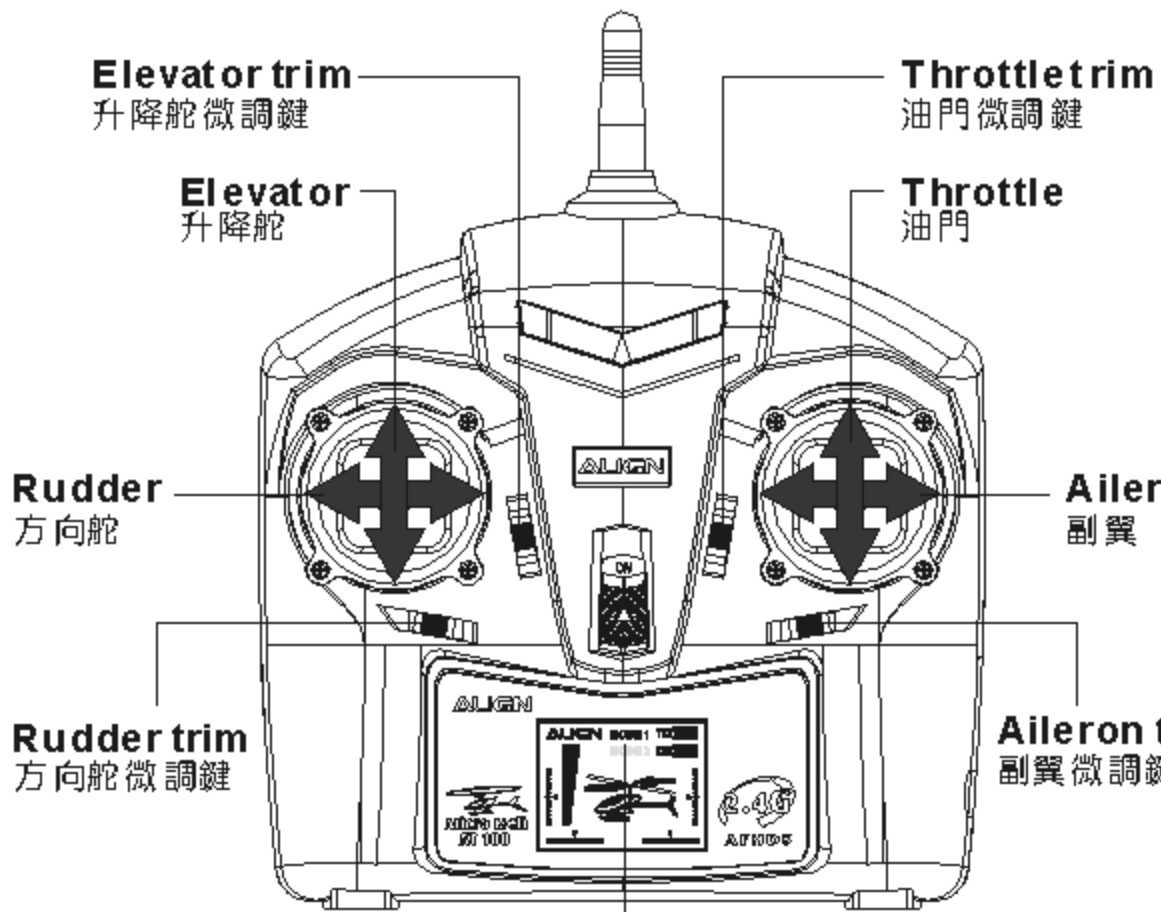

Display panel shows MODE 1, and a short beep is emitted during power up.
面板會顯示MODE 1 開機時"嗶"一短音

MODE 2

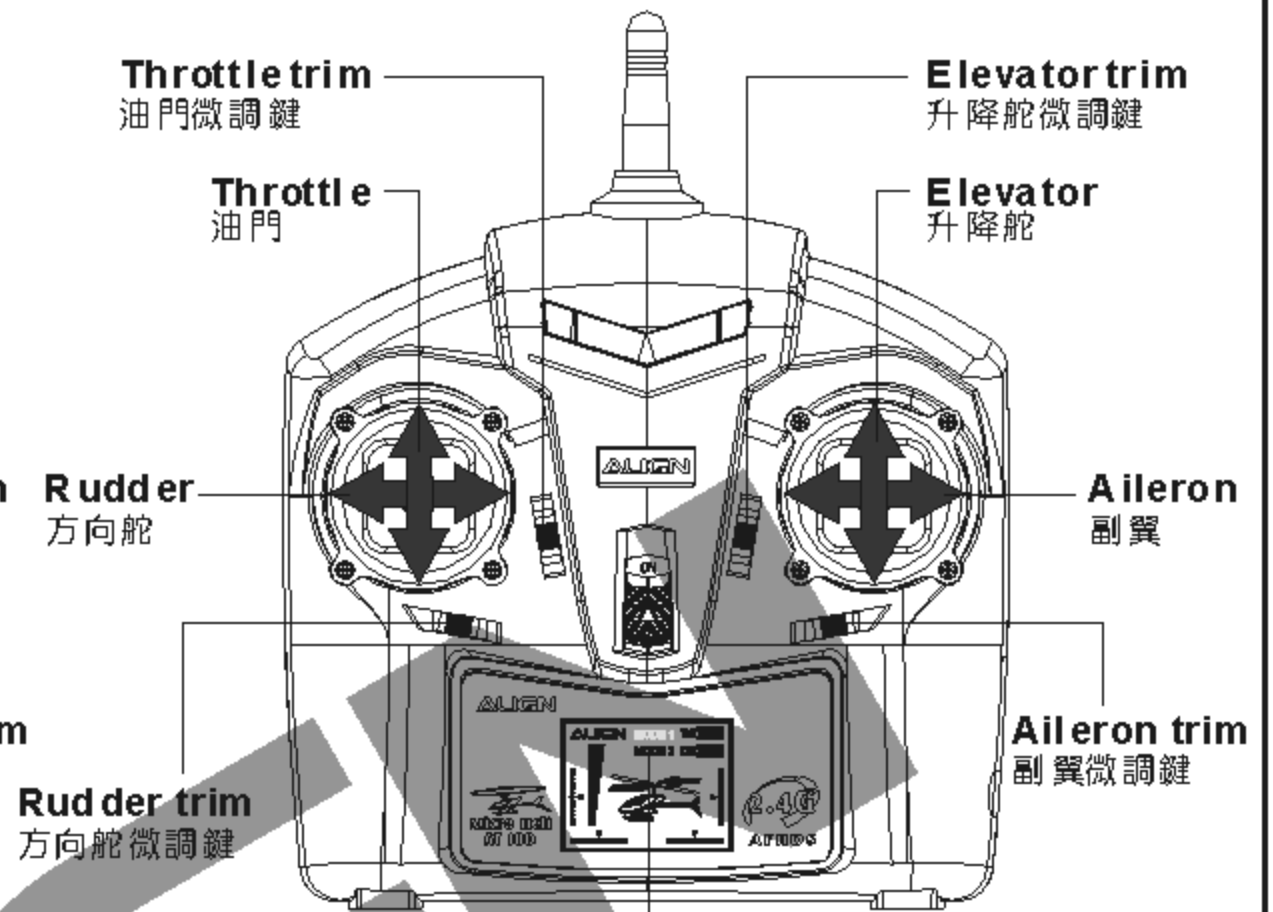

Display panel shows MODE 2, and a short beep is emitted during power up.
面板會顯示MODE 2 開機時"嗶"一短音

MODE 3

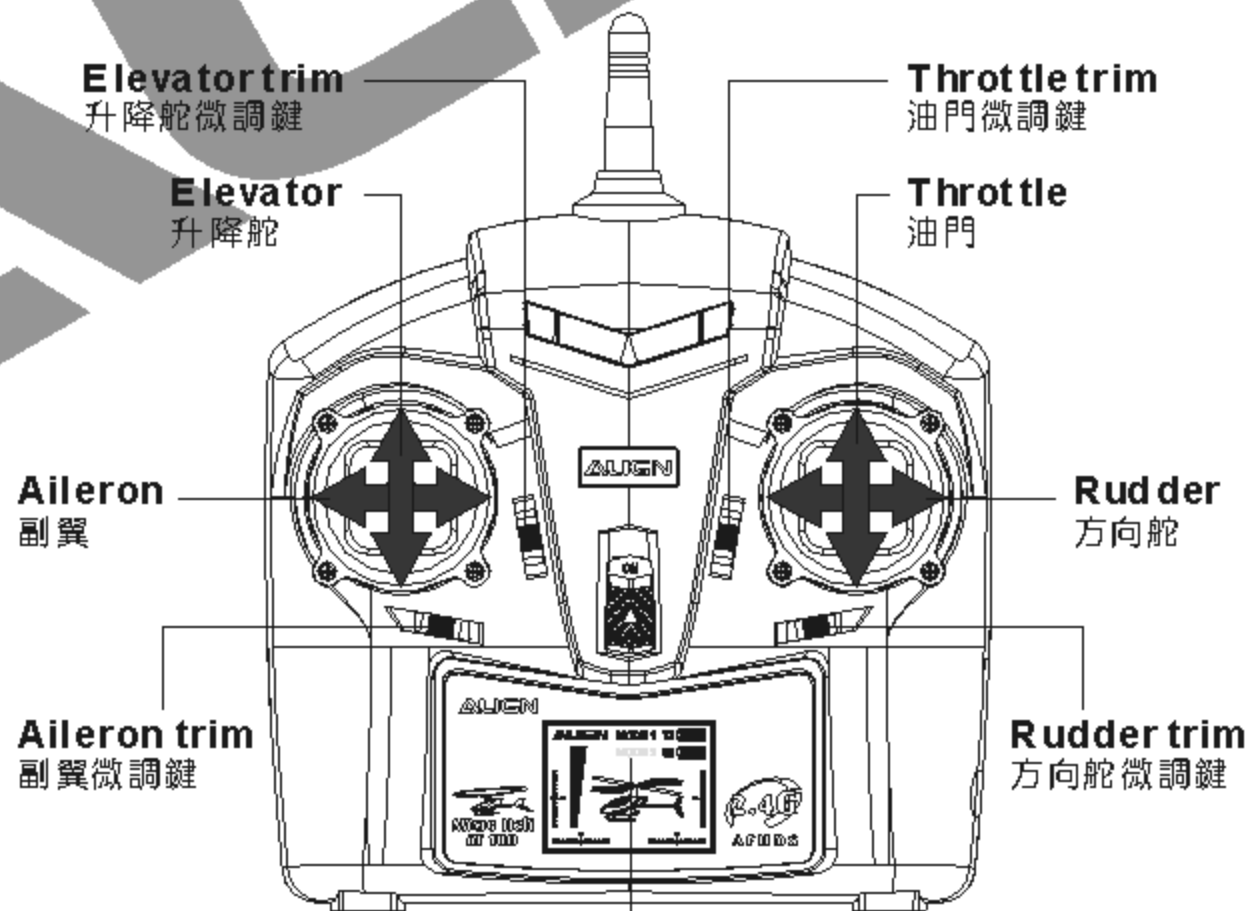

Display panel shows MODE 1, and a long beep is emitted during power up.
面板會顯示MODE 1 開機時"嗶"一長音



The control stick mode has been set at the factory. For switching to other modes, please follow instructions below.

原廠出廠時，已為您將模式設定好了，如果您需要更換其他模式請依照下列方式進行更換。

Switching between MODE1 and M ODE2 MODE 1與MODE 2的切換方式

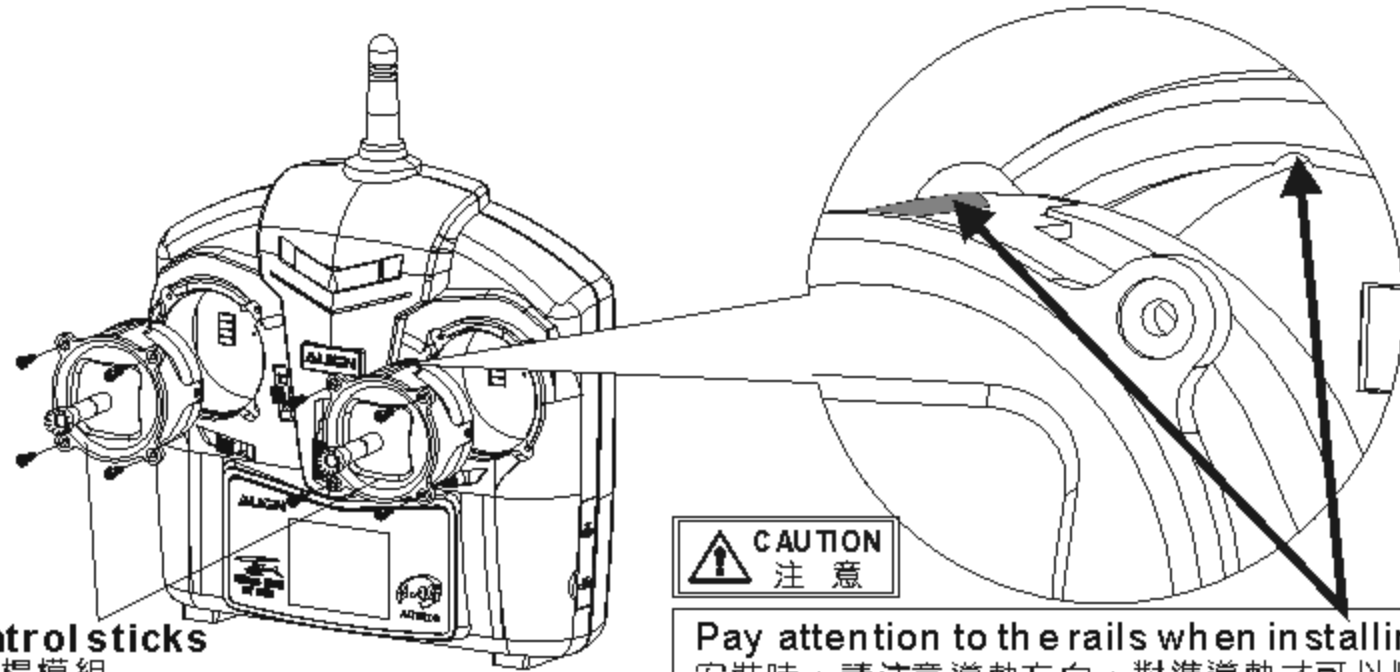

Control sticks
控制桿模組

CAUTION
注意

Pay attention to the rails when installing the control sticks.
安裝時，請注意導軌方向，對準導軌才可以順利裝入。

Loosen up the 8 screws holding the two control sticks, and swap the control sticks to change between MODE1 and MODE2.

請將控制桿的8顆螺絲鬆開，並交換控制桿模組，可切換 MODE 1及MODE 2 的操作模式。

This transmitter has trim memory capability. When the control stick modes are changed, all trims are retained so there is no need to re-trim.

本遙控器具備記憶功能，當您切換操控模式時，遙控器會自動將您原本的微調數據保留並切換，不需重新調機。

Switching between MODE3 MODE 3的切換方式

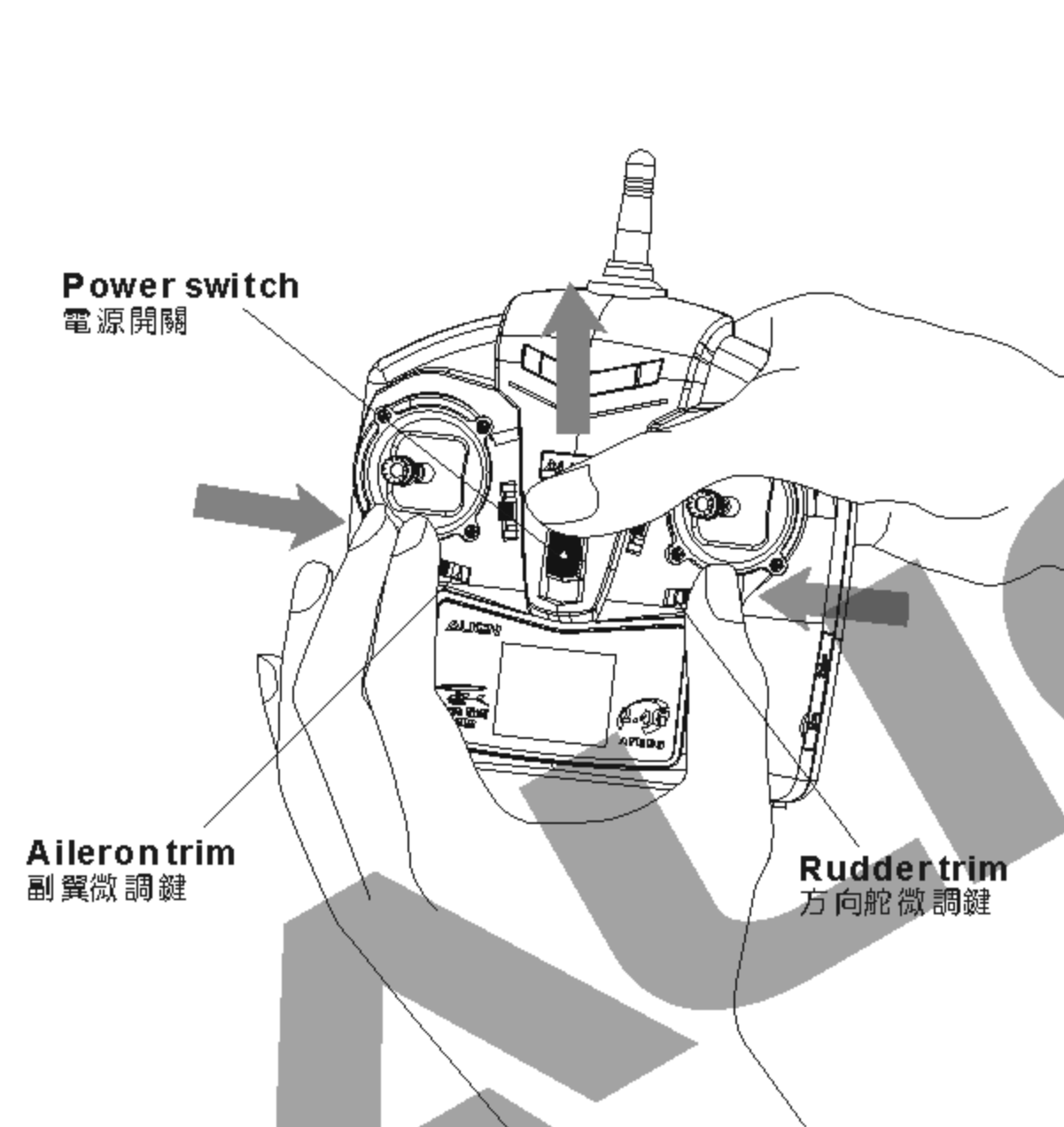

Power switch
電源開關

Aileron trim
副翼微調鍵

Rudder trim
方向舵微調鍵

CAUTION
注意

MODE3 setting needs to be set with the control sticks in MODE1 position, which means throttle is on the right hand side.

MODE 3必須在MODE 1 模式下才能切換設定，MODE 3 的油門搖桿同樣是在右手邊的位置。

Using thumb and pointer fingers, hold the aileron and rudder trim tabs toward the middle while turning on the transmitter power.

Transmitter will emit a long beep indicating MODE3 has been set. However, MODE 1 will be still indicate on the transmitter screen.

After transmitter is switched to mode 3, the mode will be retained every time when powered up, as indicated by a long beep.

To change MODE setting back to MODE1, just repeat the above procedure. Transmitter will emit a short beep indicating MODE1 has been set.

After transmitter is switched to MODE 1, the mode will be retained every time when powered up, as indicated by a short beep.

以單手食、拇指將副翼、方向舵的微調鍵往中間推著不放，接著另一手將電源開關往上推開電源，此時遙控器會發出“嗶”一長音，表示進入MODE 3 功能，但面板仍顯示MODE 1。

切換MODE 3 成功後，遙控器會記憶為MODE 3，每次開機都會“嗶”一長音。

若要切回MODE 1，只要再重複一次上述的動作，遙控器會發出“嗶”一短音，表示返回MODE 1功能。

切換MODE 1 成功後，遙控器會記憶為MODE 1，每次開機都會“嗶”一短音。

11.FLIGHT SIMULATOR USAGE INSTRUCTION 飛行模擬器使用說明

ALIGN

If you are not familiar with the controls, please practice on the PC flight simulator before you fly an actual RC helicopter. We have including the flight simulator cable and installation CD ROM in the package. Please follow the instructions to connect the transmitter with PC. Please refer to the installation instructions in the CD ROM for other settings.

當您尚未熟悉直昇機各動作的操控方式前，切勿買機飛行，請先進行電腦模擬飛行的練習。本產品隨附飛行模擬器(USB埠)與安裝光碟，請依照圖示連接遙控器與電腦，其餘設定請參照光碟的安裝說明。

The installaion instruction is including

- 1.Disc installation procedure
- 2.Lan guage Setting
- 3.Connect with your tran smitter to PC
- 4.Controller Settings
- 5.Controller mapping and Ca libration
- 6.Model and scenery import

安裝說明的內容包括：

- 1.光碟安裝步驟
- 2.顯示語言設定
- 3.模擬線連接方式
- 4.設定控制搖桿
- 5.搖桿通道對映及校準
- 6.載入模型及場景

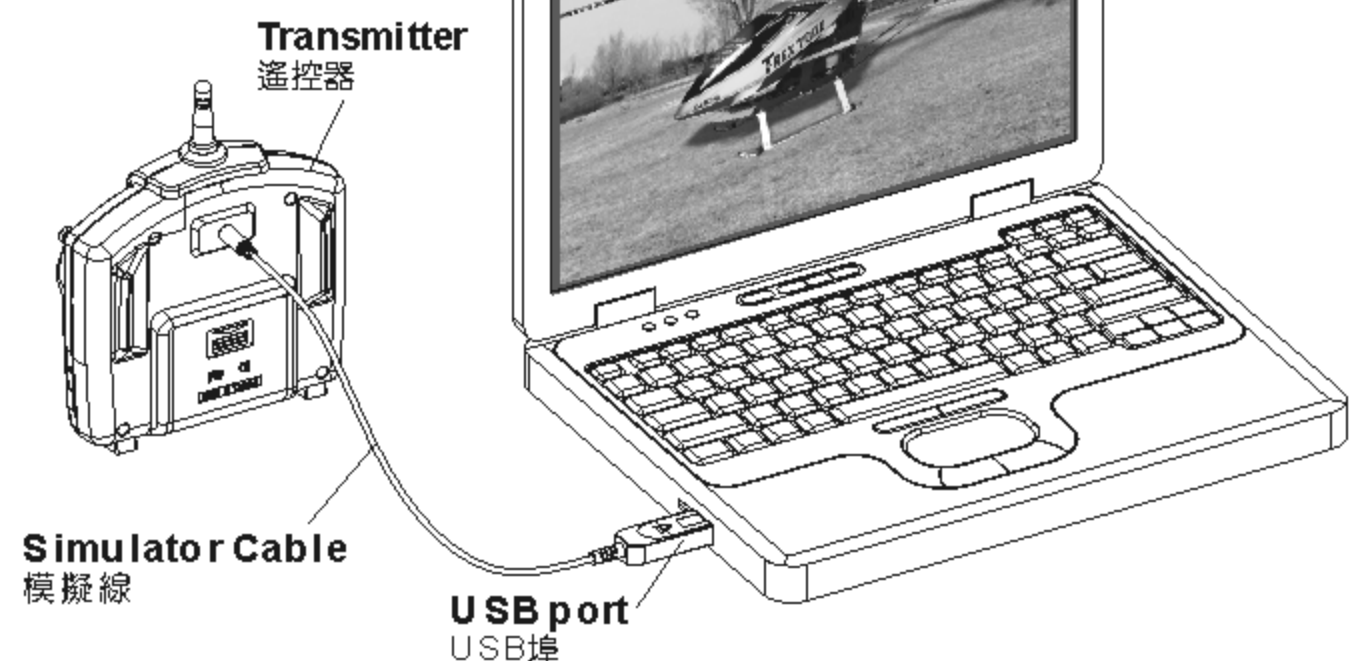

If there are frequency interference preventing completion of radio binding, please re-binding the radio of transmitter and receiver

首次使用或當頻率受到干擾而無法對頻時，必須重新對頻。

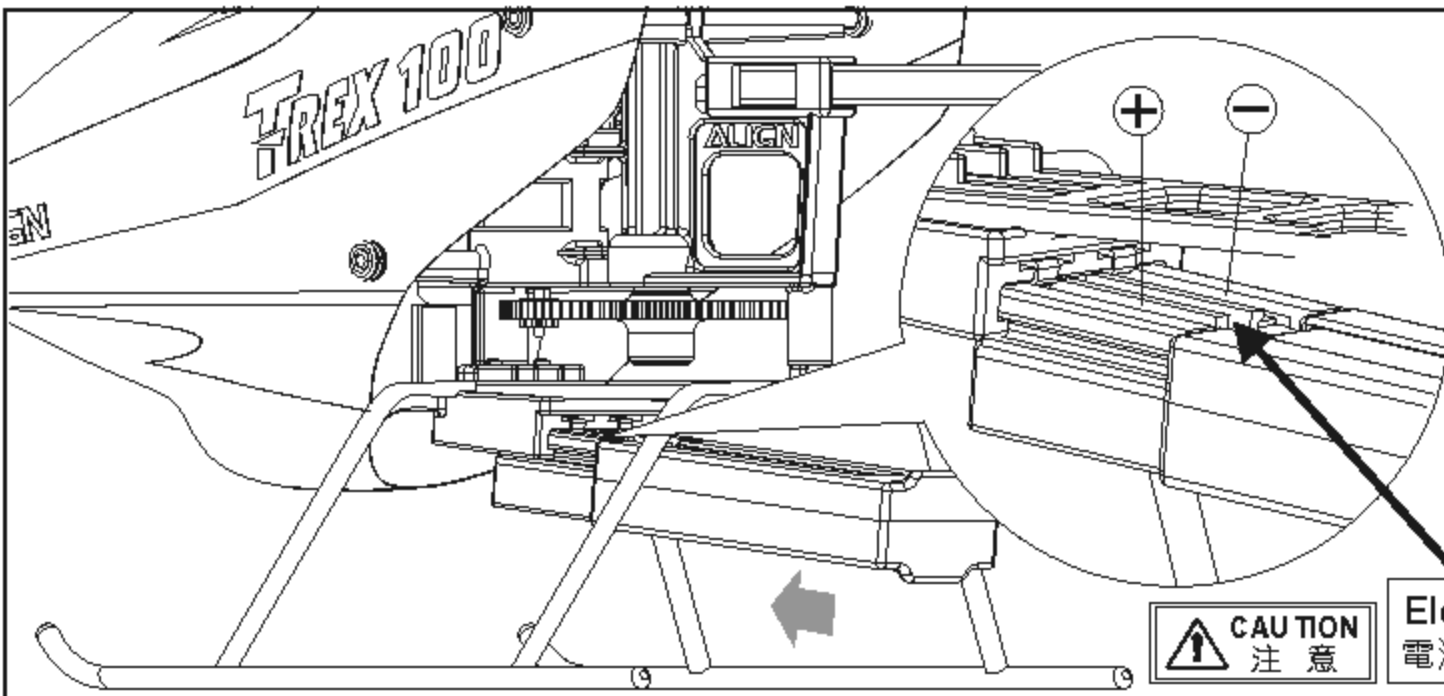

Step 1 步驟1

With the helicopter placed on level surface, push the lipo battery pack in the direction shown in diagram until fixed into position. At this time avoid moving the helicopter so the radio and gyro system can initialize and the red LED on the receiver board will be start flashing.

將直昇機置於平坦位置，依圖示方向插入Li-Po電池至定位，不要再移動機身，使陀螺儀讀取中立點，此時接收板上紅色LED燈會閃爍。

CAUTION 注意 Electrode surface of battery face up. 電池的電極面朝上。

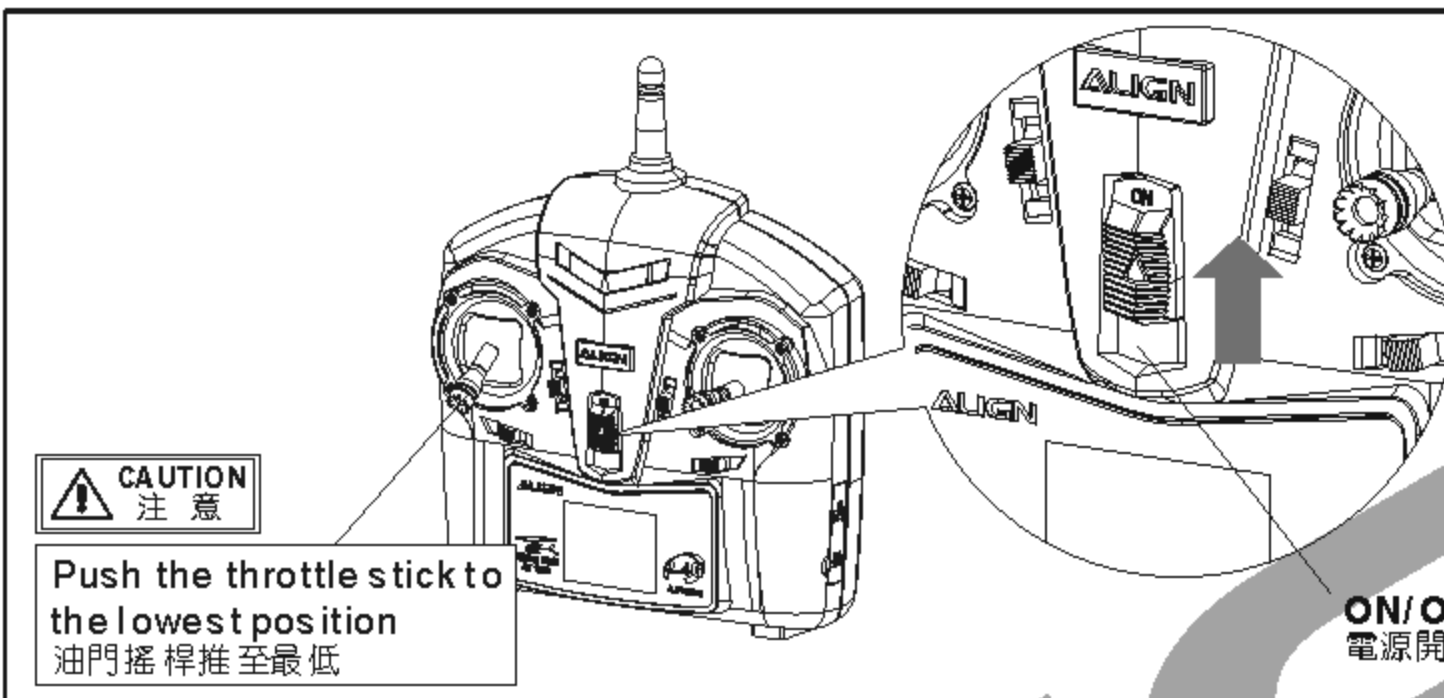

Step 2 步驟2

With throttle control stick at lowest position, turn on radio transmitter to start the binding process.

接著將油門搖桿推至最低，打開遙控器電源進行對頻。

CAUTION 注意

Push the throttle stick to the lowest position 油門搖桿推至最低

ON/OFF 電源開關

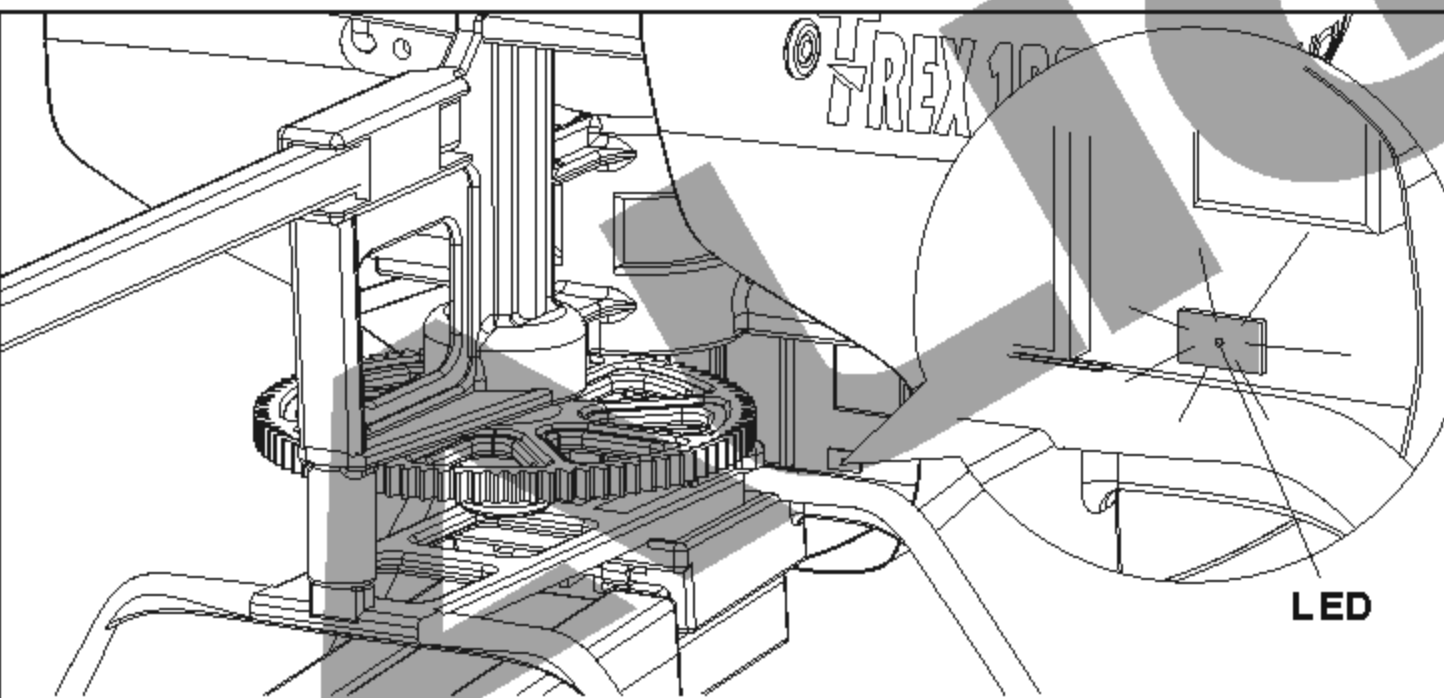

Step 3 步驟3

The red LED on receiver board will blink during radio initialization, and becomes steady after 4 seconds, indicating successful radio binding. If it continues to blink, radio binding has failed and needs to be restarted. After the radio binding is done, you don't need to re-bind it anymore.

對頻中接收板的紅色LED會閃爍，約4秒後LED恆亮表示對頻成功，若LED仍持續閃爍表示對頻失敗，必須再次執行步驟1至步驟2。只要對頻成功，每次飛行即不須再重新對頻了。

LED

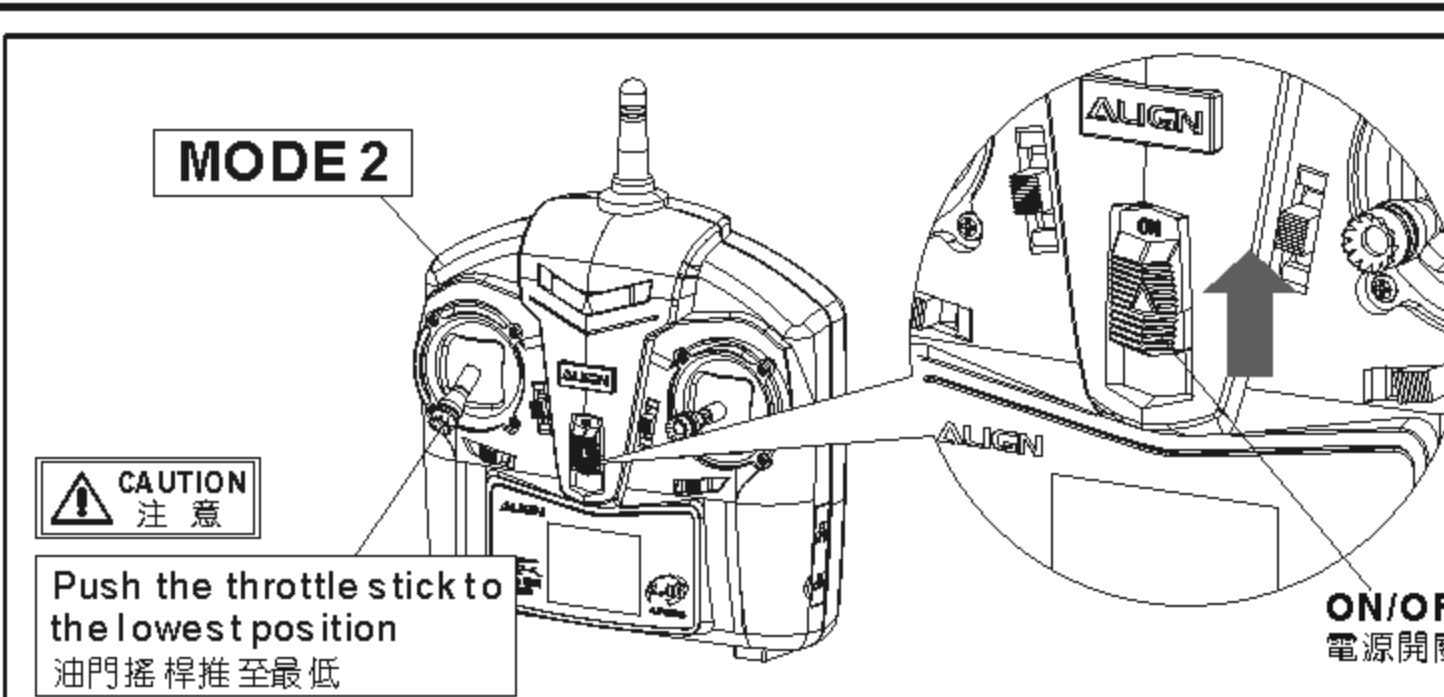

Step 1 步驟1

With the throttle control stick all the way down, turn on transmitter power.

將油門搖桿推至最低後，打開遙控器電源。

CAUTION 注意

Push the throttle stick to the lowest position 油門搖桿推至最低

ON/OFF 電源開關

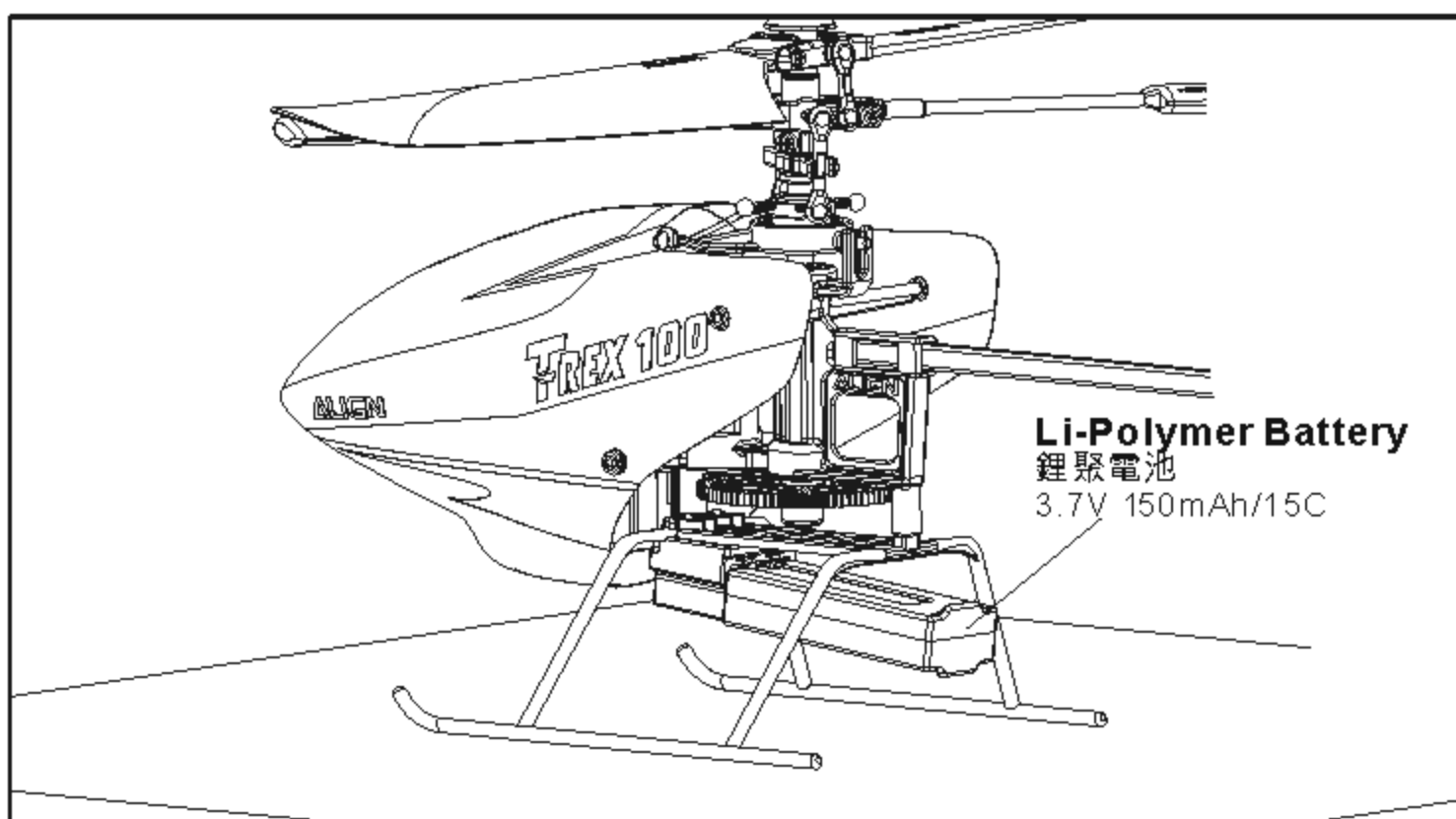

Step 2 步驟2

With the helicopter placed on level surface, push the lipo battery pack in the direction shown in diagram until fixed into position. At this time avoid moving the helicopter so the radio and gyro system can initialize, as indicated by the flashing red LED on receiver board.

請將直昇機置於平坦的位置後，將Li-po電池依圖示的方向推入電池座至定位，此時不要再移動機身，使遙控器對頻與陀螺儀讀取中立點。

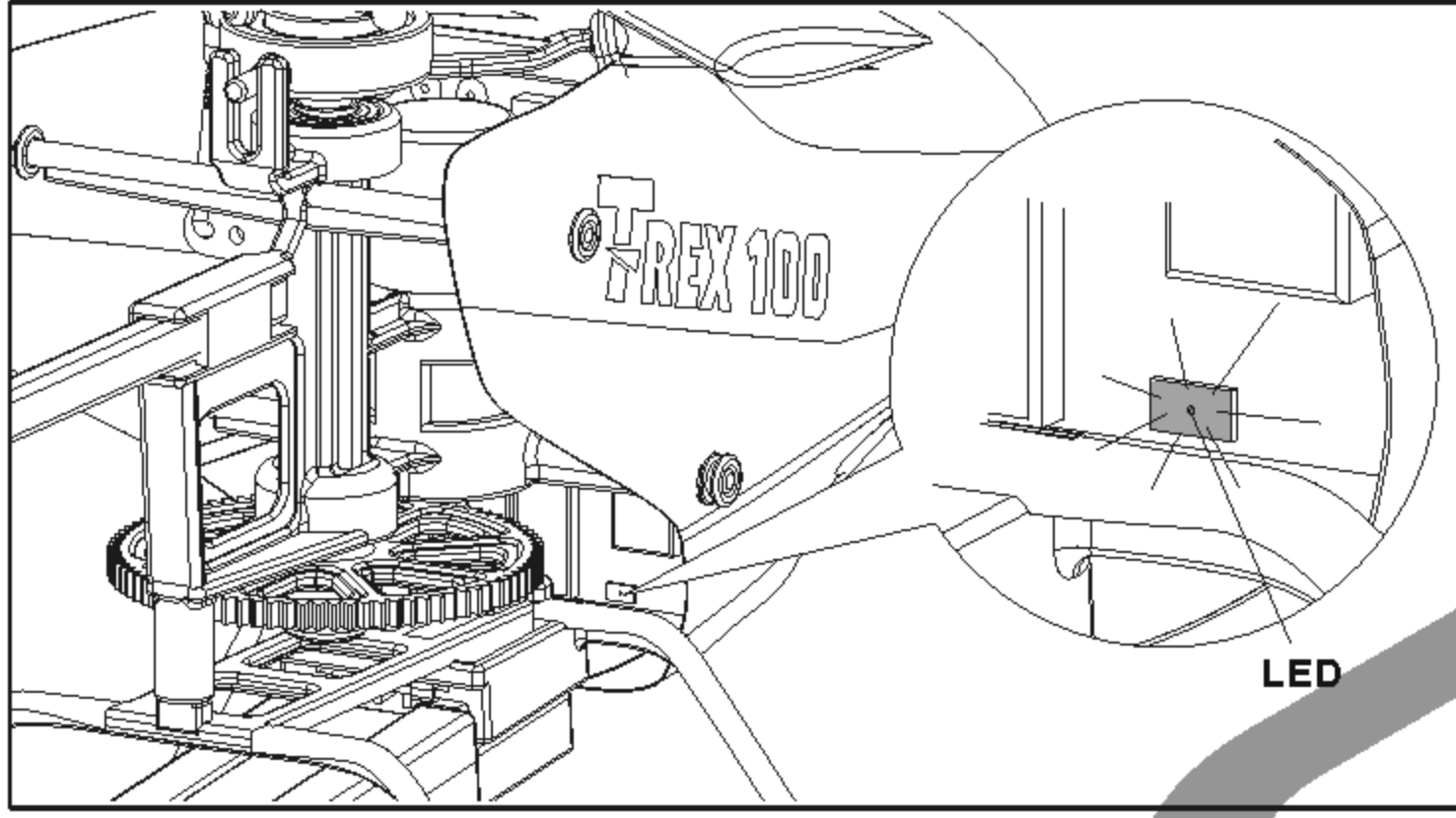

Step 3 步驟3

The red LED on receiver board will blink during radio initialization, and becomes steady after 4 seconds, indicating successful radio binding. If it continues to blink, radio binding has failed and needs to be restarted. (Refer to P.9: Binding of radio transmitter and receiver)

對頻中接收板的紅色LED會閃爍，約4秒後LED恆亮表示對頻成功，若LED仍持續閃爍表示對頻失敗，必須重新對頻。(參閱P.9 遙控器與接收器的對頻)



If helicopter is moved during initializing process, the gyro will not center properly causing helicopter rudder to yaw excessively. When this happens please go back and perform step 2 again.

對頻過程中若移動機身會導致陀螺儀中立點錯誤，飛行時直昇機尾部會嚴重偏移，請重新執行步驟2。



Check the control directions with throttle off prior to flight. 請在油門關閉的狀態下測試控制系統各動作是否正常後，才可以飛行。

Step 4-1 步驟4-1

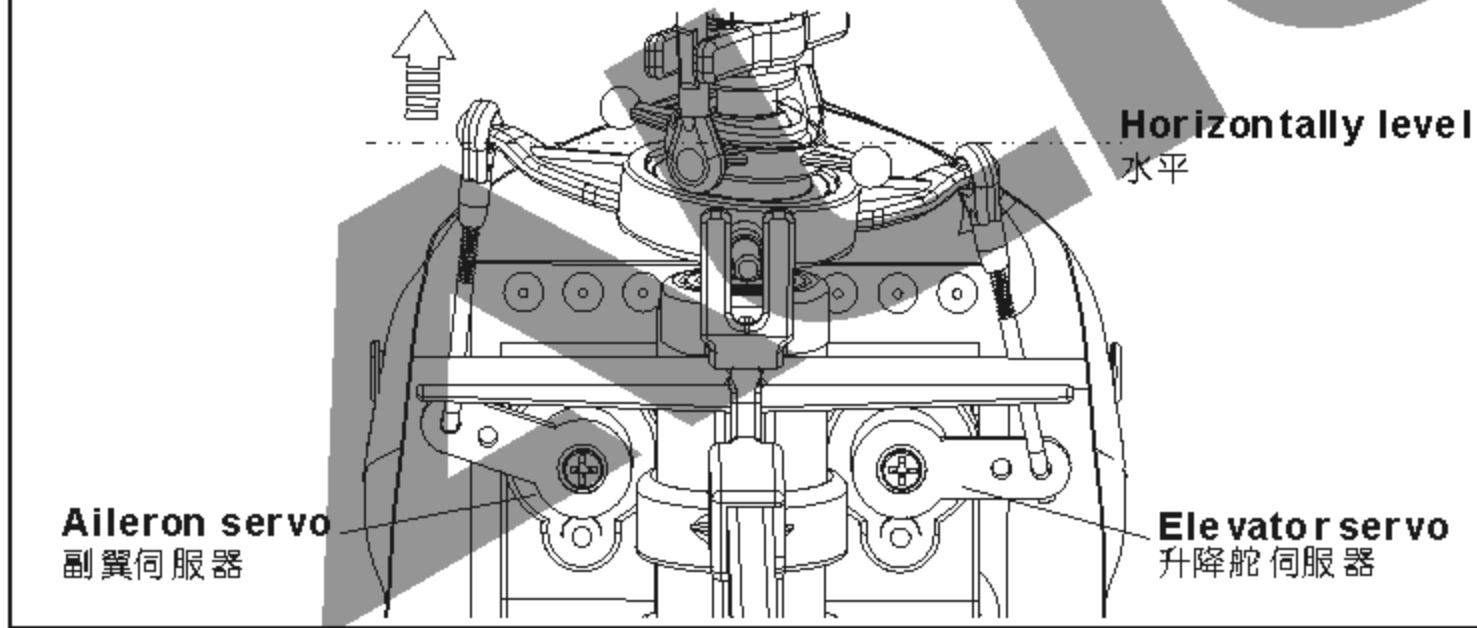

Push right on aileron control, aileron servo will push the left side of swashplate up. 副翼搖桿往右推時，副翼伺服器將十字盤的左側上推。

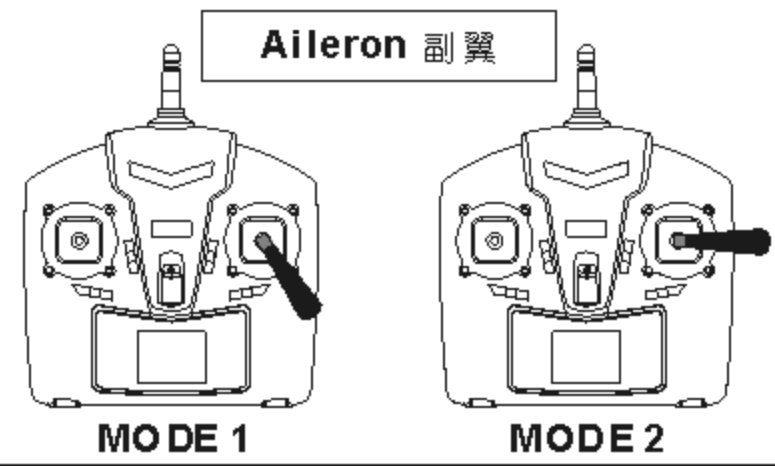

Step 4-2 步驟4-2

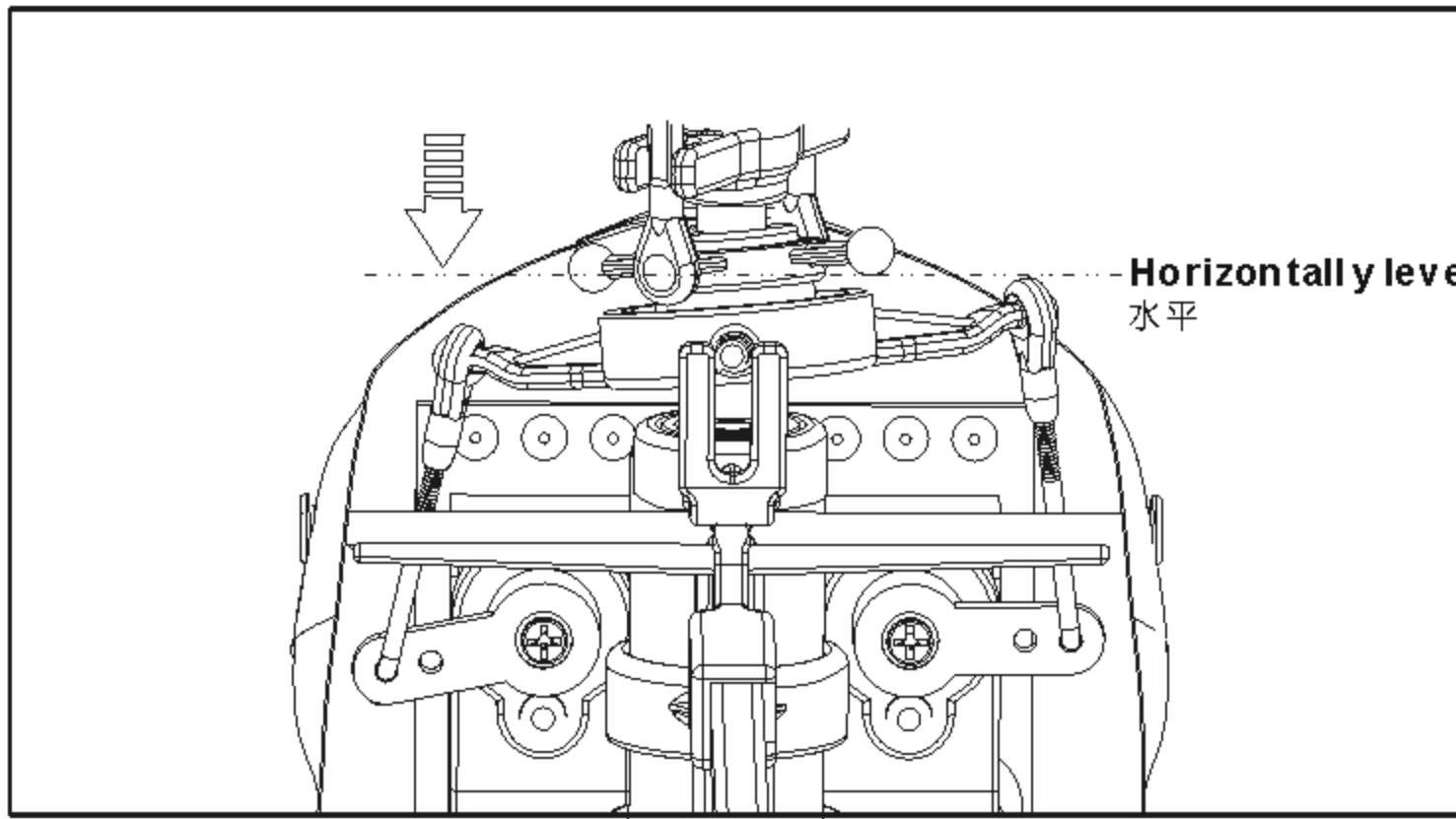

Push left on aileron control, aileron servo will push the left side of swashplate down. 副翼搖桿往左推時，副翼伺服器將十字盤的左側下拉。

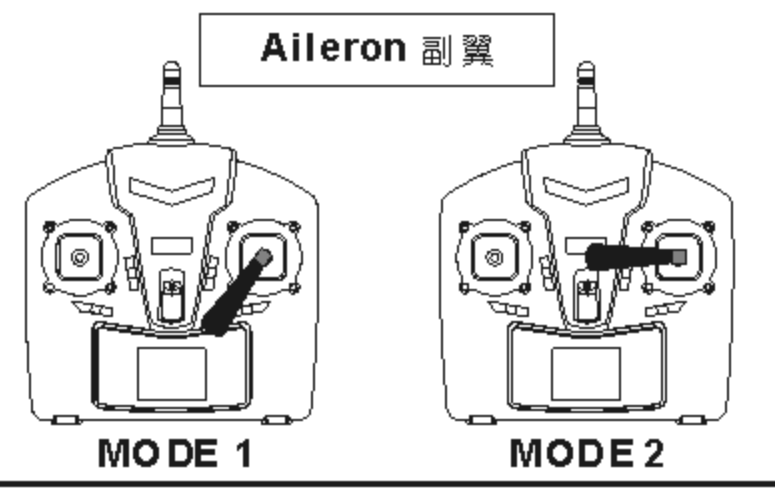

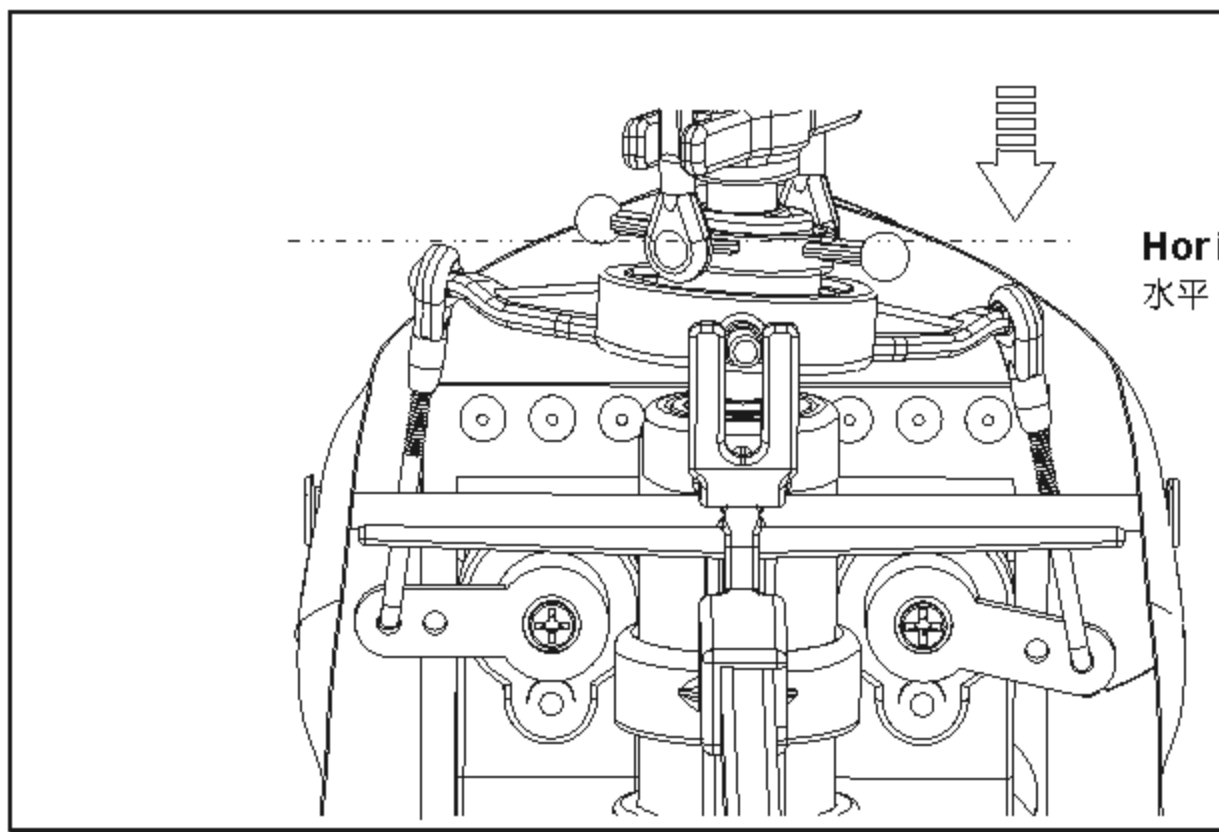

Horizontally level
水平

Step 4-3 步驟4-3

Push up on elevator control, elevator servo will push the right side of swashplate down.
升降舵搖桿往上推時，升降舵伺服器將十字盤的右側下拉。

Elevator 升降/前後

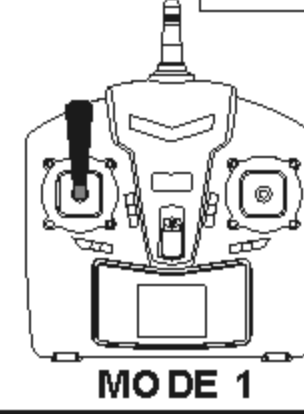

MODE 1

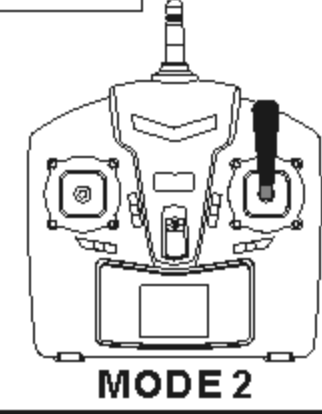

MODE 2

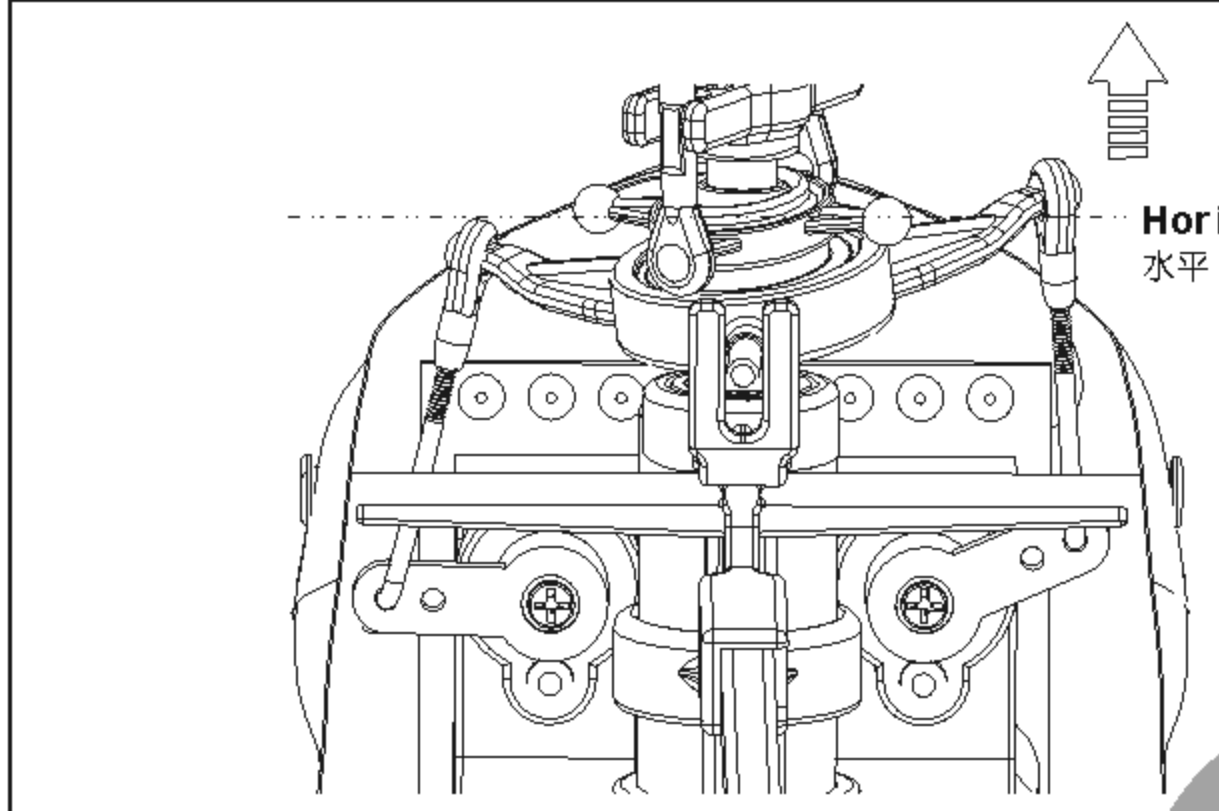

Horizontally level
水平

Step 4-4 步驟4-4

Push down on elevator control, elevator servo will push the right side of swashplate up.
升降舵搖桿往下推時，升降舵伺服器將十字盤的右側上推。

Elevator 升降/前後

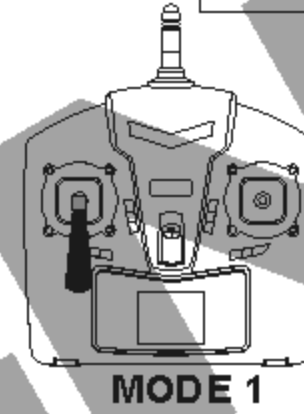

MODE 1

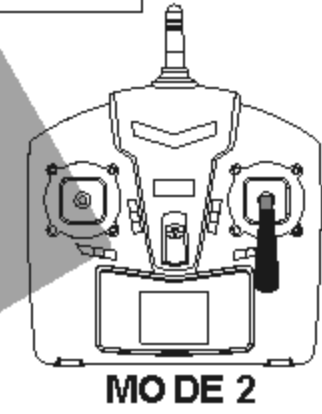

MODE 2

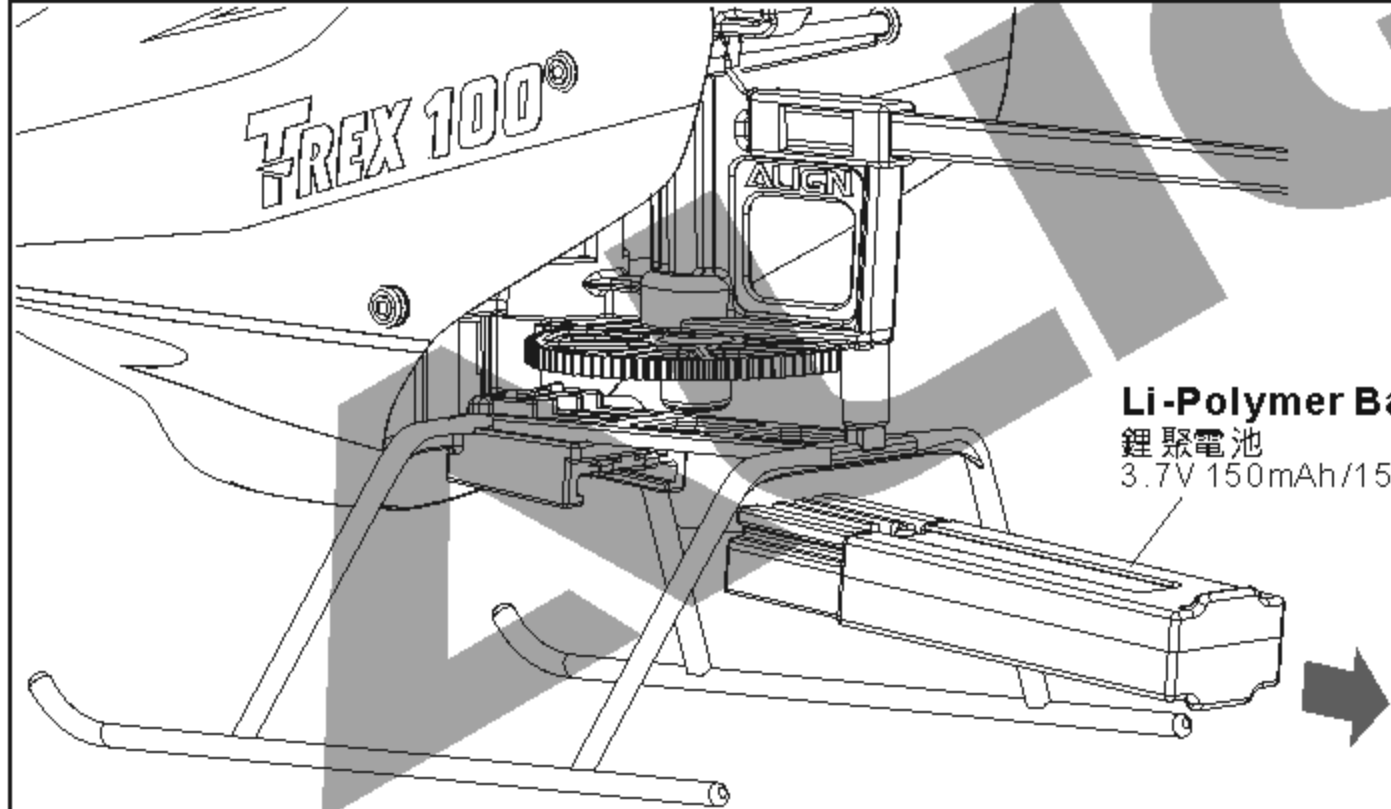

Li-Polymer Battery
鋰聚電池
3.7V 150mAh/15C

Step 5 步驟5

Remove the helicopter battery safely at the conclusion of flight. This should be made into a post flight habit to avoid unforeseeable problems.
結束飛行時，請將直昇機電池安全取下。請養成良好習慣，以免造成遺憾。



Warning: If left connected in the helicopter for long duration, the battery may be damaged due to over-discharge, or even become fire hazards.
電池未取下，將導致電池過放電而損壞，甚至造成起火燃燒的危險。

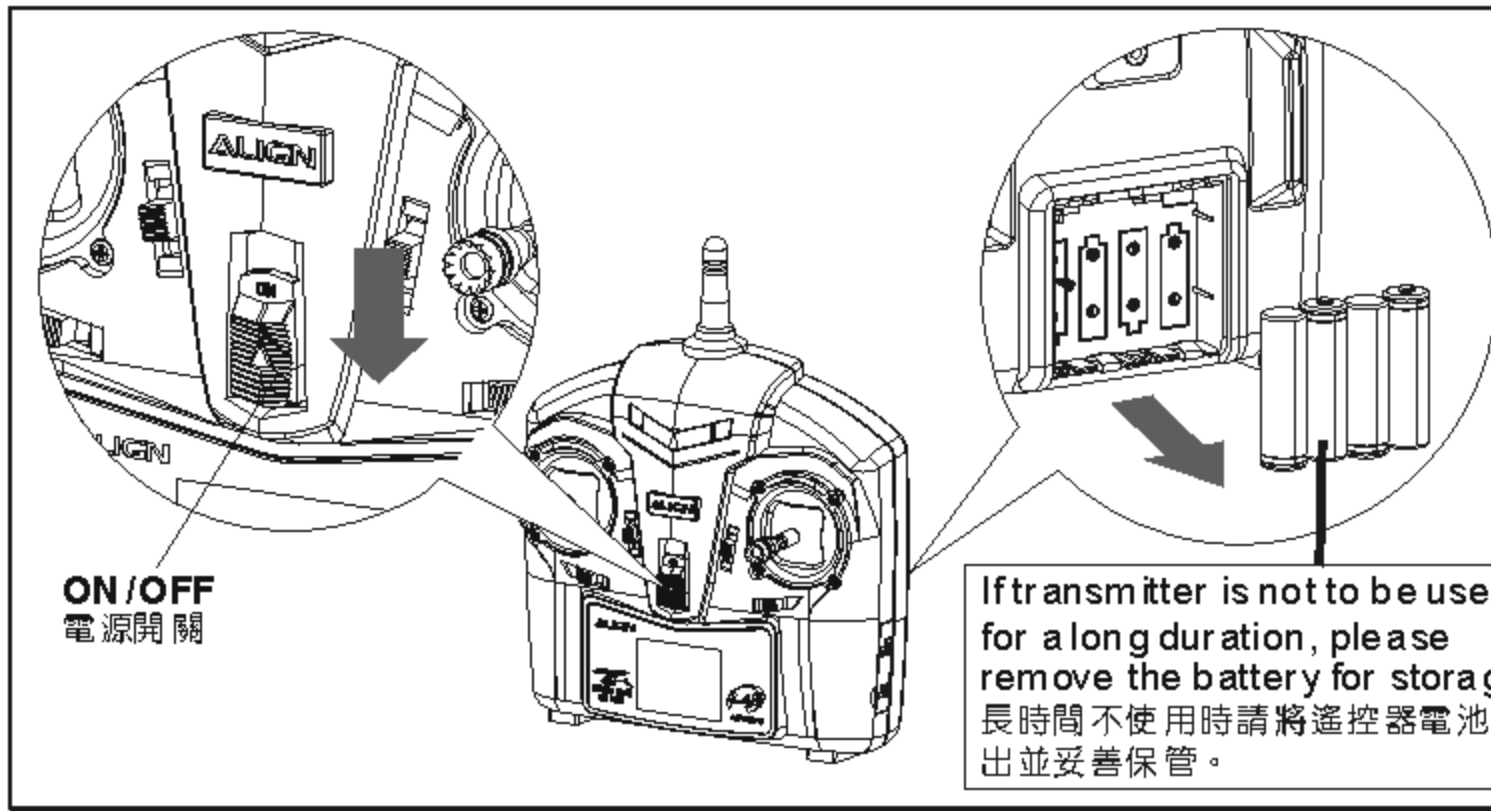

ON/OFF
電源開關

If transmitter is not to be used for a long duration, please remove the battery for storage.
長時間不使用時請將遙控器電池取出並妥善保管。

Step 6 步驟6

Turn off the transmitter. If transmitter is not to be used for a long duration, please remove the battery for storage.
關閉發射器電源，長時間不使用時請將遙控器電池取出並妥善保管。



Warning: If the AA batteries are left in the transmitter, potential leakage could occur which may damage the transmitter, and create fire hazards.
電池未取下，將導致電池漏液而損壞遙控器，甚至造成起火燃燒的危險。

PLEASE PRACTICE SIMULATION FLIGHT BEFORE ACTUAL FLYING 飛行前請事先熟練模擬飛行



Do not attempt to fly the helicopter until control methods is fully understood. **Please practice repetitively on computer flight simulators to familiarize with all directional controls.**

1. Place the helicopter in a clear open field and the tail of helicopter point to yourself.
2. Practice to operate the throttle stick (as below illustration) and repeat practicing "Throttle high/low", "Aileron left/right", "Rudder left/right", and "Elevator up/down".
3. The simulation flight practice is very important, please keep practicing until the fingers move naturally when you hear operation orders being call out.



在還沒瞭解直昇機各動作的操控方式前，嚴禁實機飛行，請先進行電腦模擬飛行的練習，熟悉各種方向的操控並不斷的重複，直到手指可熟練的控制各個動作及方向。

1. 將直昇機放在空曠的地方，並將直昇機的機尾對準自己。
2. 練習操作遙控器的各搖桿（各動作的操作方式如下圖），並反覆練習油門高/低、副翼左/右、升降舵前/後及方向舵左/右操作方式。
3. 模擬飛行的練習相當重要，請重複練習直到不需思索，手指能自然隨著喊出的指令移動控制。

Mode 1	Mode 2	Illustration 圖示	Mode 1	Mode 2	Illustration 圖示

FLIGHT ADJUSTMENT AND NOTICE FOR BEGINNERS 初學飛行調整與注意



- ⊙ Check if the screws are firmly tightened.
- ⊙ Check if the transmitter and receivers are fully charged.
- ⊙ 再次確認→螺絲是否鎖固?
- ⊙ 發射器和接收器電池是否足夠。

★ When arriving at the flying field.

★ 請在沒有人及障礙物的空曠室內飛行



- ⊙ Make sure that no people or obstructions in the vicinity.
- ⊙ You must first practice hovering for flying safety. This is a basic flight action. (Hovering means keeping the helicopter in mid air in a fixed position)
- ⊙ Please stand approximately 2m diagonally behind the helicopter.
- ⊙ 確認鄰近地區沒有人和障礙物。
- ⊙ 為了飛行安全，你必須先練習停懸，這是飛行動作的基础（停懸：直昇機滯留空中並保持固定位置）。
- ⊙ 練習時，請站在直昇機後方2公尺。

STEP 1 THROTTLE CONTROL PRACTICE 油門控制練習

Mode 1

Mode 2

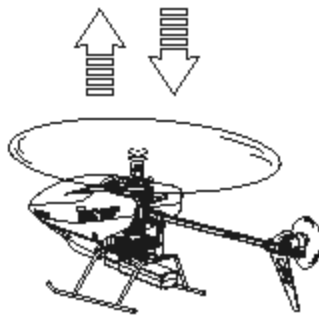
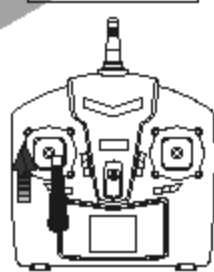
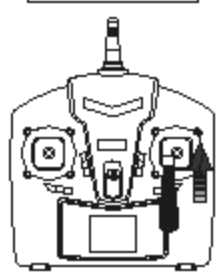

- ⊙ When the helicopter begins to lift-off the ground, slowly reduce the throttle to bring the helicopter back down. Keep practicing this action until you control the throttle smoothly.

- ⊙ 當直昇機離地後，慢慢降低油門將直昇機降下。持續練習直昇機從地面上的升和下降直到你覺得油門控制很順。



Due to tail rotor's counter-acting force, helicopter tends to naturally drift left during take off. To reduce this drifting phenomenon, Align incorporated aileron mixing to compensate for this left drift, improving take off stability.

直昇機起飛時，機身會因尾旋翼的反作用力，導致向左偏移，為了改善這個問題，亞拓特別在起飛程式裡加了混控功能，在起飛時副翼作動抵消機身向左偏移，讓直昇機起飛更加容易。

When throttle stick is raised 10%, the mixing software will command the aileron servo to push up, compensating for the natural left drift of helicopter. Once the throttle stick is raised to the middle, the helicopter will lift straight up, and cancel the drift compensation routine. Two seconds after helicopter has landed, the compensation mixing routine will reset and remain active until next lift off.

This feature makes taking off easier to learn for beginners.

當油門搖桿往上推約10%時，混控程式啟動使副翼伺服器往上推，藉以抵消機身往左偏移的力量，接著將油門搖桿順推至中間位置即可使直昇機順利離地，同時解除起飛混控功能，直昇機降落後約2秒即自動回復起飛混控模式。直昇機未離地起飛前，混控功能會一直持續，讓初學者起飛更加順利、容易。

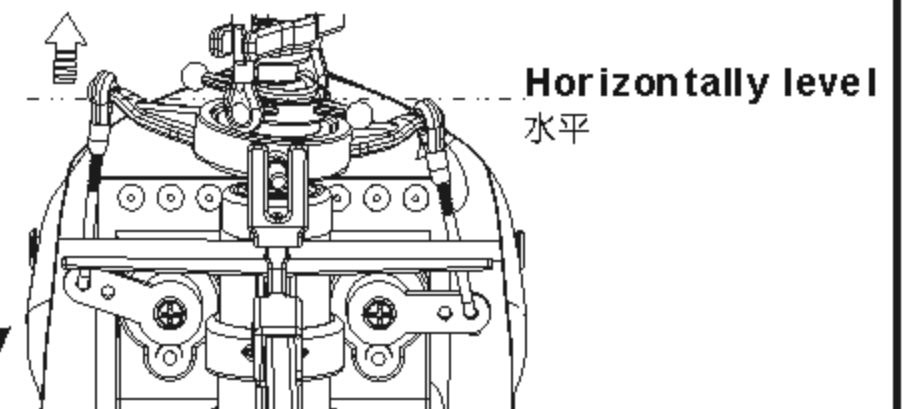

STEP 2 AILERON AND ELEVATOR CONTROL PRACTICE 副翼和升降控制練習

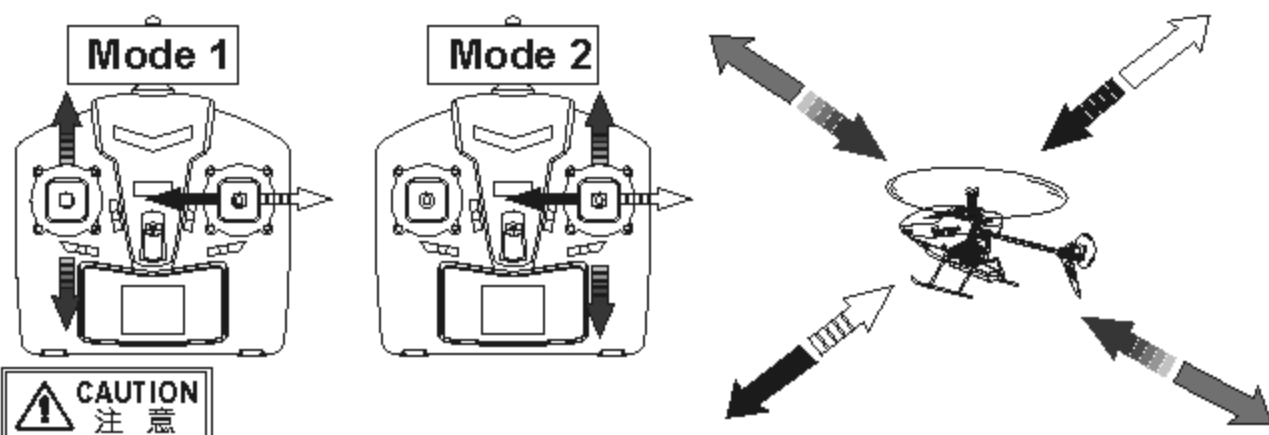

1. Raise the throttle stick slowly.
2. Move the helicopter in any direction back, forward, left and right, slowly move the aileron and elevator sticks in the opposite direction to fly back to its original position.

1. 慢慢升起油門搖桿。
2. 使直昇機依指示: 移動向後/向前/向左/向右, 慢慢的反向移動副翼和升降搖桿並將直昇機開回到原來位置。



- ⊙ If the nose of the helicopter moves, please lower the throttle stick and land the helicopter. Then move your position diagonally behind the helicopter 2m and continue practicing.
- ⊙ If the helicopter flies too far away from you, please land the helicopter and move your position behind 2m and continue practicing.
- ⊙ 當直昇機機頭偏移時, 請降低油門並且降落, 然後移動自己的位置到直昇機的正後方2公尺再繼續練習。
- ⊙ 假如直昇機飛離你太遠, 請先降落直昇機, 並到直昇機後2公尺再繼續練習。

STEP 3 RUDDER CONTROL PRACTICING 方向舵操作練習

1. Slowly raise the throttle stick.
 2. Move the nose of the helicopter to right or left, and then slowly move the rudder stick in the opposite direction to fly back to its original position.
1. 慢慢升起油門搖桿。
 2. 將直昇機機頭移動左或右, 然後慢慢反向移動方向舵搖桿並將直昇機飛回原本位置。

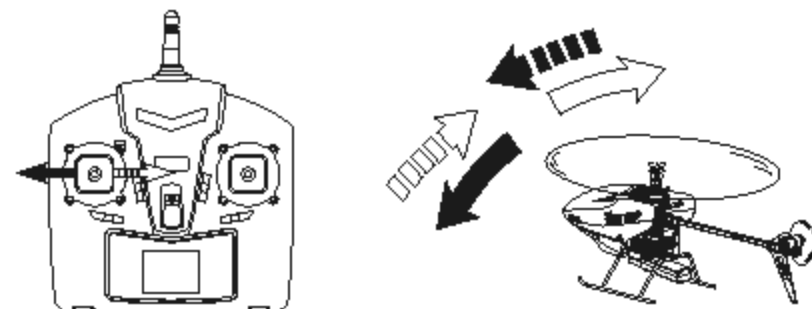

STEP 4

After you are familiar with all actions from Step 1 to 3, draw a circle on the ground and practice within the circle to increase your accuracy.

當你覺得 step 1~3 動作熟悉了, 在地上畫圈並在這個圈圈的範圍內練習飛行, 以增加你操控的準確度。

⊙ You can reduce the size of the circle as you become familiarized with the control reflexes.

⊙ 當你更加習慣操作動作, 你可以畫更小的圈圈。

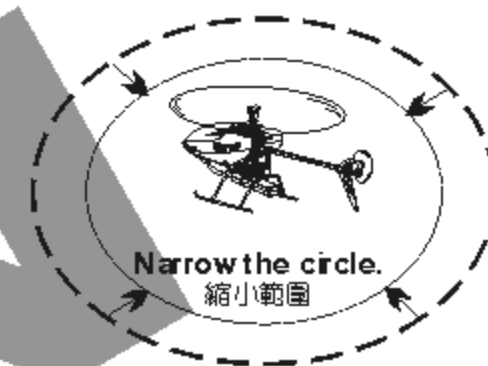

STEP 5 DIRECTION CHANGE AND HOVERING PRACTICE 改變直昇機方向和練習停懸

After you are familiar with Step 1 to 4, stand at side of the helicopter and continue practicing Step 1 to 4. Then repeat the Step 1 to 4 by standing in front of the helicopter.

當你覺得 step 1~4 動作熟悉了, 站在面對直昇機側邊並繼續練習 step 1~4。之後, 站在直昇機機頭前方重複步驟練習。

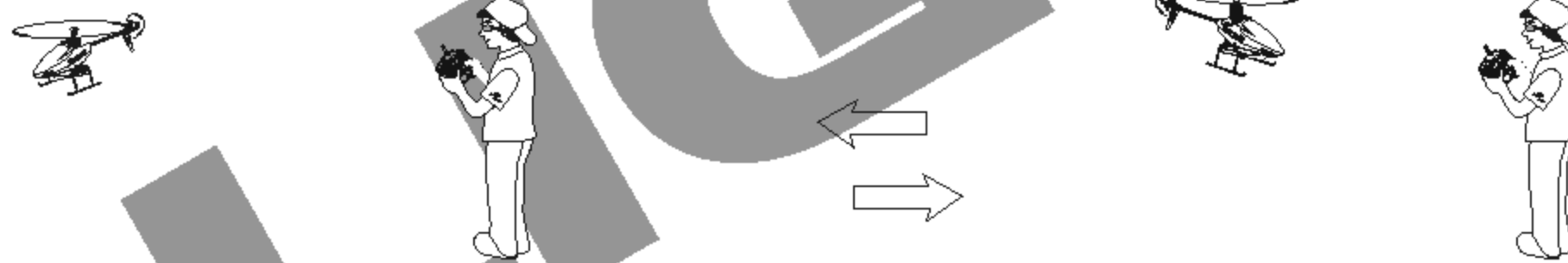

ADJUSTMENT OF EACH TRIM 飛行動作微調

Slowly raise the throttle stick and just as the helicopter lift-off the ground, you can use the trim to correct the action if the helicopter leans in a different direction.

慢慢升起油門搖桿, 當直昇機剛剛離開地面時, 若直昇機傾向不同方向, 可使用微調修正動作。

1. Adjustment of rudder trim 調整方向舵微調

Just before the helicopter lift-off, the nose lean left/right...

When leans right, adjust the trim to left side.

When leans left, adjust the trim to right side.

在直昇機正要起飛時, 機頭朝左/右方向偏移...

向右偏移時, 微調向左調整。

向左偏移時, 微調向右調整。

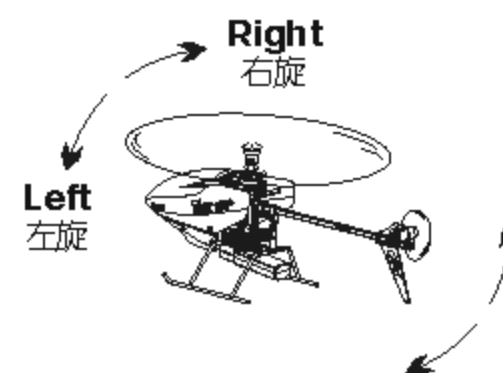
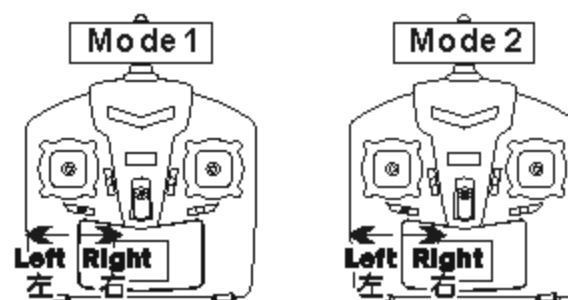

2. Adjustment of elevator trim 調整升降舵微調

Just before the helicopter lift-off, the nose lean forward/backward...

When leans forward, adjust the trim down.

When leans backward, adjust the trim up.

在直昇機正要起飛時, 機頭朝前/後方向偏移...

向前偏移時, 微調向下調整。

向後偏移時, 微調向上調整。

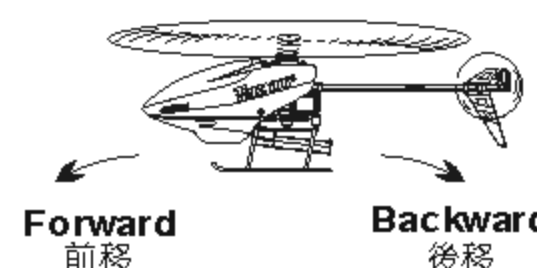
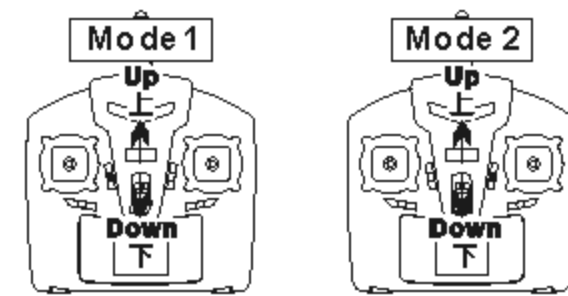

3. Adjustment of aileron trim 調整副翼微調

Just before the helicopter lift-off, the body lean left/right...

When leans right, adjust the trim to left side.

When leans left, adjust the trim to right side.

在直昇機正要起飛時, 機身朝左/右方向偏移...

向右偏移時, 微調向左調整。

向左偏移時, 微調向右調整。

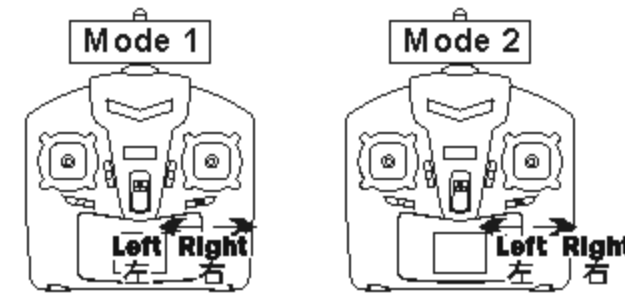

	Situation 狀況	Cause 原因	Way to deal 對策
1	Receiver status LED blinks continuously for more than 4 seconds after helicopter battery inserted. No response to control input. 接上直昇機電池後接收器指示燈持續閃爍，操作無反應	Unable to bind to transmitter. 遙控器與接收器未對頻成功	Repeat the power up initializing process. (Refer to P.9: Binding of radio transmitter and receiver) 請重新執行遙控器與接收機板的對頻動作 (請參閱P.9 遙控器與接收器的對頻)
2	No response after battery is connected to helicopter. 接上直昇機電池後，直昇機沒有任何反應	1. power to transmitter and receiver. 2. Check transmitter and receiver voltage. 3. Poor contact on battery terminals. 1. 檢查遙控器和接收器是否接通電源 2. 檢查遙控器和接收電池的電壓 3. 電池極片接觸不良	1. Turn on transmitter and ensure helicopter battery is inserted properly. 2. Use fully charged batteries. 3. Re-seat the battery and ensure good contact between battery contacts. 1. 打開發射器與確實插入直昇機電池至定位 2. 使用完全充電充飽的電池 3. 重新插入電池，確認電池和電池極片的接觸是否正確
3	Motor does not respond to throttle stick, receiver LED flashes. 推動油門搖桿時馬達不轉，且接收器指示燈開始閃爍。	Helicopter battery depleted. 直昇機鋰聚電池電量不足	Fully charge the battery, or replace with a fully charged battery. 將電池充電或更換另一個充飽的電池
4	Main rotor continue to spin after landing 降落之後，主旋翼仍在旋轉未停止	Throttle trim accidentally increased during flight. 飛行中誤將油門微調調高	Confirm throttle trim is in center or slightly below. 確認油門微調在中間位置或是稍微向下調
5	Motor fails to run, but servo moves. 馬達不轉，但伺服器仍有動作	1. Throttle trim is too high, triggering safety protection function. 2. Throttle was not all the way down during power up. 3. Loose motor connection or damaged motor. 1. 油門微調偏高，啟動安全保護功能 2. 開機時，油門搖桿未置於最低點 3. 馬達接頭鬆脫或馬達損壞	1. Lower throttle trim and restart throttle. 2. Lower throttle stick all the way down and restart throttle. 3. Re-seat the motor plug or replace the motor. 1. 調低油門微調後重新啟動油門 2. 將油門搖桿推至最低點後，重新啟動油門 3. 將接頭插至定位或更換馬達
6	Main rotor spins but unable to takeoff. 直昇機主旋翼有持續轉動但不能起飛	1. Deformed main blades. 2. Helicopter battery depleted 1. 主旋翼變形 2. 直昇機電池電量不足	1. Replace main blades 2. Charge or replace with a fully charged battery. 1. 更換主旋翼 2. 將電池充電或是更換另一個充飽的電池
7	Strong vibration of helicopter 直昇機震動的很厲害	1. Deformed main blades 2. Bent main shaft 3. Deformed tail rotor 4. Overtightening of main blade grips. 1. 主旋翼變形 2. 主軸彎曲 3. 尾旋翼變形 4. 主旋翼固定座螺絲鎖太緊，導致偏擺	1. Replace main blades 2. Replace main shaft 3. Replace tail rotor 4. Re-tighten main blade grips with suitable force. 1. 更換主旋翼 2. 更換主軸 3. 更換尾旋翼 4. 依適當力道重新鎖附主旋翼固定座螺絲
8	Tail still off trim after trim tab adjustment, or inconsistent speed during left/right pirouette. 已調整尾舵微調，但尾部仍會偏向一邊或左旋/右旋速度不一致	1. Damaged tail rotors 2. Damaged tail drive motor 3. Helicopter was not stationary during power up. 4. Vibration induced gyro interference, causing tail unable to lock. 1. 尾旋翼變形 2. 尾馬達不良 3. 接上直昇機電源時機身未保持在靜止狀態 4. 機身異常震動，陀螺儀受干擾，尾舵無法鎖定	1. Replace tail rotors 2. Replace tail drive motor 3. Re-power the helicopter while remaining stationary. 4. Refer to symptom 7. 1. 更換尾旋翼 2. 更換尾驅動馬達 3. 重接電源並保持直昇機在靜止狀態 4. 請參考問題7
9	Helicopter still wanders forward after trim adjustment during hover. 停懸時已調整微調，但是直昇機仍會往前或往後偏移	1. Elevator servo not level during power up. 2. Elevator pushrod too long or too short. 1. 開機時升降伺服器擺臂未置於水平位置 2. 升降控制連桿過長或過短	1. Center elevator trim after power up, and re-install elevator servo horn at level position. 2. If helicopter drifts forward, adjust linkage longer. If it drifts backward, adjust linkage shorter. 1. 開機後將升降微調歸中立點，重新裝上擺臂使擺臂水平。 2. 往前偏移時連桿調長，往後偏移時連桿調短
10	Helicopter still wanders left/right after trim adjustment during hover. 停懸時已調整微調，但是直昇機仍會往左或往右偏移	1. Aileron servo not level during power up. 2. Aileron pushrod too long or too short. 1. 開機時副翼伺服器擺臂未置於水平位置 2. 副翼控制連桿過長或過短	1. Center aileron trim after power up, and re-install aileron servo horn at level position. 2. If helicopter drifts left, adjust linkage longer. If it drifts right, adjust linkage shorter. 1. 開機後將副翼微調歸中立點，重新裝上擺臂使擺臂水平。 2. 往左偏移時連桿調長，往右偏移時連桿調短

	Situation 狀況	Cause 原因	Way to deal 對策
11	Helicopter unable to remain stationary during hover 停懸時機身無法定點	1. Binding caused by rough components 2. Overtightening of mixing arms. 1. 機構干涉順暢度不足 2. 控制臂鎖太緊干涉	1. Confirm smooth movements of components and ball links. 2. Loosen up mixing arms axial screws. 1. 確認機身每一個機構及連桿頭作動順暢 2. 放鬆軸套螺絲讓控制臂作動順暢
12	Unusual vibration of helicopter during flights 直昇機飛行時機身異常抖動	1. Binding between main blades and blade grips. 2. Insufficient head speed due to depletion of helicopter battery. 1. 主旋翼和主旋翼固定座干涉 2. 直昇機電池電壓不足，主旋翼轉速太慢	1. Ensure all head components are smooth with no binding. 2. Replace with a fully charged battery. 1. 確認主旋翼頭組的每個機構活動順暢不干涉 2. 請更換一個充電完成的新電池

※If the problem is still there even after tried above, stop flying and contact with your seller.
※在做完以上調整後，仍然無法改善情況時，應立即停止飛行並連絡您的經銷商。

16.PARTS LIST 各部零件名稱

ALIGN

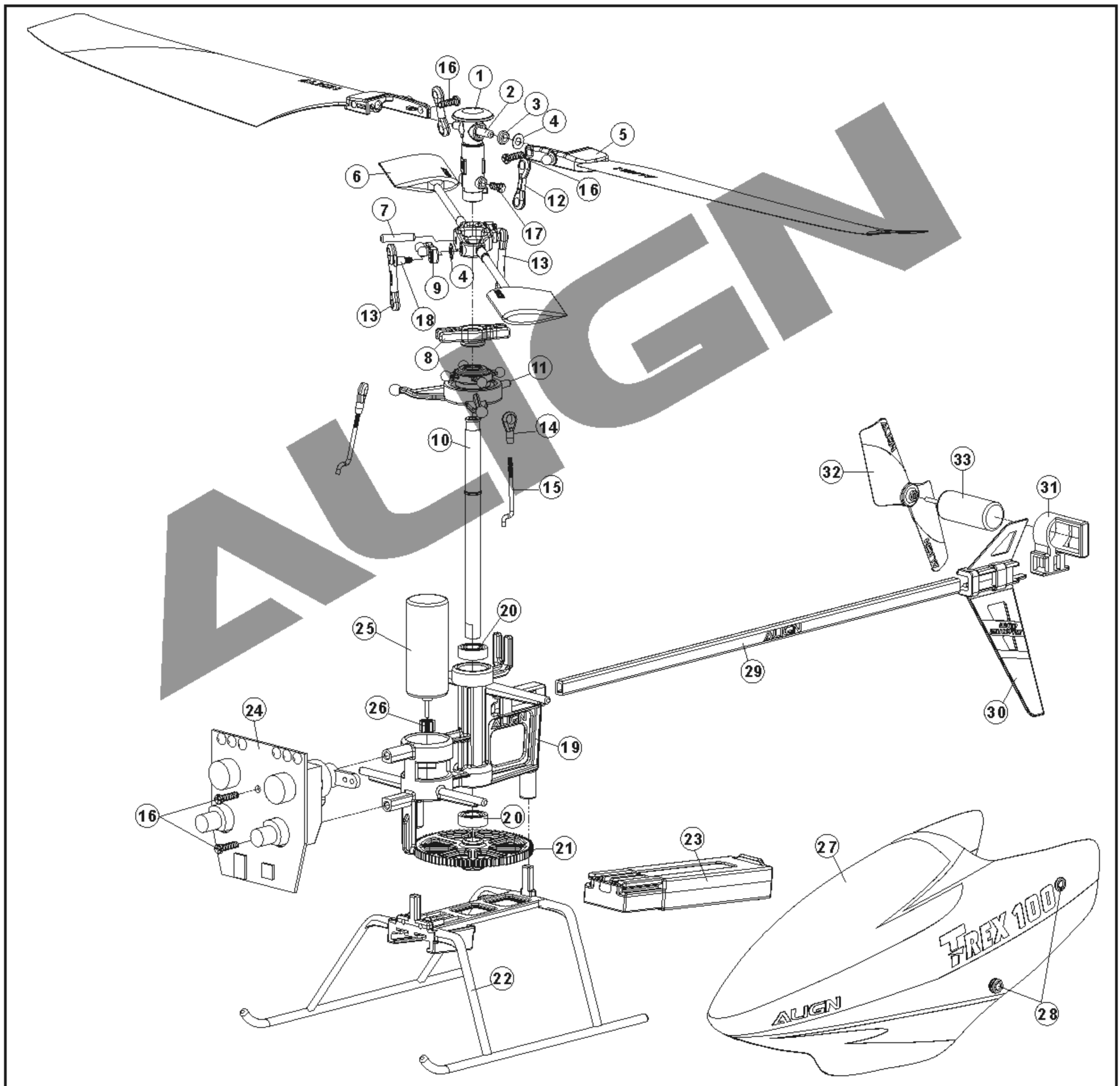

No.	Code No.	Name	Specification	Quantity	Remarks
1	10H001	Main rotor housing 主旋翼固定座	18.8x6x4.4 mm	1	
2	10H011	Feathering shaft 橫軸	φ 1.5x11mm	1	
3	10H013	Damper rubber 橫軸墊圈	φ 1.5x φ 2.8x1mm	2	
4	10H012	Collar 橫軸墊片	φ 1.6x φ 3.2x0.2mm	4	
5	10H009	Blade 主旋翼	102x20.8x6.7mm	2	
6	10H002	Flybar rod 平衡桿	126x13.4x3.2mm	1	
7	10H011	Pin 平衡桿插梢	φ 1.5x7mm	1	
8	10H003	Washout base 向位器	15x3.9x3.5 mm	1	
9	10H004	Washout control arm 控制臂	6.2x2.8mm	2	
10	10H005	Main shaft 主軸	φ 1.6x φ 3x45.8mm	1	
11		Swashplate 十字盤組		1	
12	10Z001	Ball link A 連桿頭A	φ 2.1x7.6x1.3mm	2	
13	10Z002	Ball link B 連桿頭B	φ 2.1x11x1.3mm	2	
14	10Z003	Ball link 連桿頭	φ 2.1x5x1.3mm	2	
15	10Z004	Linkage rod 機身連桿	φ 0.6x12.5mm	2	
16	S51404	Screw 圓頭十字自攻螺絲	T1.4x4mm	4	
17	S51425	Screw 圓頭十字自攻螺絲	T1.4x2.5mm	1	
18	T11232	Collar screw 圓頭十字軸套螺絲	M1.2x3.2mm	2	
19	10B001	Main frame 機身	33.7x36.1mm	1	
20	HH63	Bearing 軸承	φ 3x φ 6x2mm	2	
21	10BA00	Main drive gear 主齒輪		1	
22	10F001	Landing skid 腳架	52x29.6mm	1	
23	KV910015	Li-Polymer Battery 鋰聚電池	3.7V/150mAh/15C	2	
24	ER10021	Receiver board 接收板		1	
25	MB10001	Motor 主馬達		1	
26	10M001	Motor pinior gear 馬達齒輪		1	
27	10C001	Canopy 彩繪機頭罩		1	
28	10H014	Canopy nut 機頭罩墊圈	φ 1.4x φ 3x1.5mm	4	
29	10T001	Tail boom 尾管	2.2x2.9x115mm	1	
30	10T002	Horizontal stabilizer 垂直翼	42.4x17.5x4.4mm	1	
31	10T003	Tail motor mount 尾馬達座	φ 7x φ 7.5x11.7mm	1	
32	10T004	Tail blade 尾旋翼	φ 0.8x φ 2.2x39.1mm	1	
33	MB10021	Tail Motor 尾馬達		1	

Specifications, contents of parts and availability are subject to change, Align RC is not responsible for inadvertent errors in this publication.

本說明書內的材質、規格或零件包裝之內容物僅供參考。本公司將不對此印刷物之異動負責，也無法主動通知消費者，任何更新或異動，請以亞拓網頁為主。

ALIGN

Specifications & Equipment/規格配備:

T-REX 100S

Length/機身長:202mm

Height/機身高: 82mm

Main Blade Length/主旋翼長:192mm

Tail Rotor Diameter/尾旋翼直徑:36mm

Weight(Without Power System)/空機重:27.8g

Flying Weight/全配重:Approx. 32g

