

Combo T-REX 700E

INSTRUCTION MANUAL 使用說明書

KX018E05T

ALIGN



Contents	
1	INTRODUCTION 前言
1~2	SAFETY NOTES 安全注意事項
3	EQUIPMENT REQUIRED FOR ASSEMBLY 自備設備
3	PACKAGE ILLUSTRATION 包裝說明
4	SAFETY CHECK BEFORE FLYING 飛行前安全檢查
5~19	ASSEMBLY SECTION 組裝說明
20	EQUIPMENT INSTALLATION 各項設備配置圖
21	BATTERY INSTALLATION ILLUSTRATION 電池安裝示意圖
22	INSTALLATION FOR ESC AND BEC 無刷調速器與BEC安裝
22	CANOPY ASSEMBLY 機頭罩安裝
23	ELECTRIC EQUIPMENT ILLUSTRATION 電子設備建議配置圖示
24	SERVO SETTING AND ADJUSTMENT 伺服器設定調整
24	ADJUSTMENTS FOR GYRO AND TAIL NEUTRAL SETTING 陀螺儀與尾翼中立點調整
25	PITCH AND THROTTLE SETTING 主旋翼螺距與油門設定
26	SUGGESTIONS FOR ESC SETTING ESC無刷調速器設定建議說明
26	6A EXTERNAL BEC INSTRUCTION MANUAL 6A外接式BEC使用說明
27	RCM-BL700MX 510KV POWER COLLOCATION REFERENCE 原裝動力數據參考表
27~30	FLIGHT ADJUSTMENT AND SETTING 飛行動作調整與設定

Thank you for buying ALIGN products. The **T-REX 700E** is the latest technology in Rotary RC models. Please read this manual carefully before assembling and flying the new **T-REX 700E** helicopter. We recommend that you keep this manual for future reference regarding tuning and maintenance.

承蒙閣下選用亞拓遙控世界系列產品，謹表謝意。進入遙控世界之前必須告訴您許多相關的知識與注意事項，以確保您能夠在學習的過程中較得心應手。在開始操作之前，請務必詳閱本說明書，相信一定能夠給您帶來相當大的幫助，也請您妥善保管這本說明書，以作為日後參考。

Thank you for buying ALIGN Products. The T-REX 700E Helicopter is designed as an easy to use, full featured Helicopter R/C model capable of all forms of rotary flight. Please read the manual carefully before assembling the model, and follow all precautions and recommendations located within the manual. Be sure to retain the manual for future reference, routine maintenance, and tuning.

The T-REX 700E is a new product developed by ALIGN. It provides flying stability for beginners, full aerobatic capability for advanced fliers, and unsurpassed reliability for customer support.

感謝您選購亞拓產品，為了讓您容易方便的使用 T-REX 700E 直昇機，請您詳細的閱讀完這本說明書之後再進行組裝以及操作這台直昇機，同時請您妥善的保存這本說明書，作為日後進行調整以及維修的參考。

T-REX 700E 是由亞拓自行研發的新產品，不論你是需求飛行穩定性的初學者或是追求性能的飛行愛好者，T-REX 700E 將是你最佳的選擇。

THE MEANING OF SYMBOLS 標誌代表涵義

 WARNING 警告	Mishandling due to failure to follow these instructions may result in damage or injury. 因為疏忽這些操作說明，而使用錯誤可能造成財產損失或嚴重傷害。
 CAUTION 注意	Mishandling due to failure to follow these instructions may result in danger. 因為疏忽這些操作說明，而使用錯誤可能造成危險。
 FORBIDDEN 禁止	Do not attempt under any circumstances. 在任何禁止的環境下，請勿嘗試操作。

IMPORTANT NOTES 重要聲明

R/C helicopters, including the T-REX 700E are not toys. R/C helicopter utilize various high-tech products and technologies to provide superior performance. Improper use of this product can result in serious injury or even death. Please read this manual carefully before using and make sure to be conscious of your own personal safety and the safety of others and your environment when operating all ALIGN products.

Manufacturer and seller assume no liability for the operation or the use of this product. Intended for use only by adults with experience flying remote control helicopters at a legal flying field. After the sale of this product we cannot maintain any control over its operation or usage.

T-REX 700E 遙控直昇機並非玩具，它是結合了許多高科技產品所設計出來的休閒用品，所以商品的使用不當或不熟悉都可能會造成嚴重傷害甚至死亡，使用之前請務必詳讀本說明書，勿輕忽並注意自身安全。

注意！任何遙控直昇機的使用，製造商和經銷商是無法對使用者於零件使用的損耗異常或組裝不當所發生之意外負任何責任，本產品是提供給有操作過模型直昇機經驗的成人，或有相當技術的人員在旁指導於當地合法遙控飛行場飛行，以確保安全無虞下操作使用。產品售出後本公司將不負任何操作和使用控制上的任何性能與安全責任。

We recommend that you obtain the assistance of an experienced pilot before attempting to fly our products for the first time. A local expert is the best way to properly assemble, setup, and fly your model for the first time. The Helicopter requires a certain degree of skill to operate, and is a consumer item. Any damage or dissatisfaction as a result of accidents or modifications are not covered by any warrantee and cannot be returned for repair or replacement. Please contact our distributors for free technical consultation and parts at discounted rates when you experience problems during operation or maintenance.

模型商品屬於需高操作技術且為消耗性之商品，如經拆裝使用後，會造成不等情況零件損耗，任何使用情況所造成商品不良或不滿意，將無法於保固條件內更換新品或退貨，如遇有使用操作維修問題，本公司全省分公司或代理商將提供技術指導、特價零件供應服務。

2. SAFETY NOTES 安全注意事項



Fly only in safe areas, away from other people. Do not operate R/C aircraft within the vicinity of homes or crowds of people. R/C aircraft are prone to accidents, failures, and crashes due to a variety of reasons including, lack of maintenance, pilot error, and radio interference. Pilots are responsible for their actions and damage or injury occurring during the operation or as of a result of R/C aircraft models.

遙控模型飛機、直昇機屬高危險性商品，飛行時務必遠離人群，人為組裝不當或機件損壞、電子控制設備不良，以及操控上的不熟悉、都有可能導致飛行失控損傷等不可預期的意外，請飛行者務必注意飛行安全，並需了解自負疏忽所造成任何意外之責任。



LOCATE AN APPROPRIATE LOCATION 遠離障礙物及人群

R/C helicopters fly at high speed, thus posing a certain degree of potential danger. Choose an a legal flying field consisting of flat, smooth ground without obstacles. Do not fly near buildings, high voltage cables, or trees to ensure the safety of yourself, others and your model. For the first practice, please choose a legal flying field and can use a training skid to fly for reducing the damage. Do not fly your model in inclement weather, such as rain, wind, snow or darkness.

直昇機飛行時具有一定的速度，相對的也潛在著危險性，場地的選擇也相對的重要，請需遵守當地法規到合法遙控飛行場地飛行。必須注意周遭有沒有人、高樓、建築物、高壓電線、樹木等等，避免操控的不當造成自己與他人財產的損壞。初次練習時，務必選擇在空曠合法專屬飛行場地並適當搭配練習架練習飛行，這對飛行失誤所造成的損傷將會大幅的降低。請勿在下雨、打雷等惡劣天候下操作，以確保本身及機體的安全。



PREVENT MOISTURE 遠離潮濕環境

R/C models are composed of many precision electrical components. It is critical to keep the model and associated equipment away from moisture and other contaminants. The introduction or exposure to water or moisture in any form can cause the model to malfunction resulting in loss of use, or a crash. Do not operate or expose to rain or moisture.

直昇機內部也是由許多精密的電子零組件組成，所以必須絕對的防止潮濕或水氣，避免在浴室或雨天時使用，防止水氣進入機身內部而導致機件及電子零件故障而引發不可預期的意外！



PROPER OPERATION 勿不當使用本產品

Please use the replacement of parts on the manual to ensure the safety of instructors. This product is for R/C model, so do not use for other purpose.

請勿自行改造加工，任何的升級改裝或維修，請使用亞拓產品目錄中的零件，以確保結構的安全。請確認於產品限界內操作，請勿過載使用，並勿用於安全、法令外其它非法用途。



OBTAIN THE ASSISTANCE OF AN EXPERIENCED PILOT 避免獨自操控

Before turning on your model and transmitter, check to make sure no one else is operating on the same frequency. Frequency interference can cause your model, or other models to crash. The guidance provided by an experienced pilot will be invaluable for the assembly, tuning, trimming, and actual first flight. (Recommend you to practice with computer-based flight simulator.)

至飛行場飛行前，需確認是否有相同頻率的好手正進行飛行，因為開啓相同頻率的發射機將導致自己與他人立即干擾等意外危險。遙控飛機操控技巧在學習初期有著一定的難度，要盡量避免獨自操作飛行，需有經驗的人士在旁指導，才可以操控飛行。(勤練電腦模擬器及老手指導是入門必要的選擇)



SAFE OPERATION 安全操作

Operate this unit within your ability. Do not fly under tired condition and improper operation may cause in danger.

請於自己能力內及需要一定技術範圍內操作這台直昇機，過於疲勞、精神不佳或不當操作，意外發生風險將可能會提高。



ALWAYS BE AWARE OF THE ROTATING BLADES 遠離運轉中零件

During the operation of the helicopter, the main rotor and tail rotor will be spinning at a high rate of speed. The blades are capable of inflicting serious bodily injury and damage to the environment. Be conscious of your actions, and careful to keep your face, eyes, hands, and loose clothing away from the blades. Always fly the model a safe distance from yourself and others, as well as surrounding objects. Never take your eyes off the model or leave it unattended while it is turned on. Immediately turn off the model and transmitter when you have landed the model.

當直昇機主旋翼與尾旋翼運轉時，切勿觸摸並遠離任何物件，以避免造成危險及損壞。



KEEP AWAY FROM HEAT 遠離熱源

R/C models are made up various forms of plastic. Plastic is very susceptible to damage or deformation due to extreme heat and cold climate. Make sure not to store the model near any source of heat such as an oven, or heater. It is best to store the model indoors, in a climate-controlled, room temperature environment.







遙控飛機多半是以 PA 纖維或聚乙烯、電子商品為主要材質，因此要盡量遠離熱源、日曬，以避免因高溫而變形甚至熔毀損壞的可能。











3.EQUIPMENT REQUIRED FOR ASSEMBLY 自備設備

ALIGN

RADIO TRANSMITTER AND ELECTRONIC EQUIPMENT REQUIRED FOR ASSEMBLY 自備遙控及電子設備

 <p>Transmitter (7-channel or more, helicopter system) 發射機(七動以上直昇機模式遙控器)</p>	 <p>Receiver(7-channel or more) 接收機(七動以上)</p>	 <p>Li-Po Battery Charger Li-Po電池充電器</p>
 <p>22.2V 6S 4500~5200mAh Li-Po Battery x 2pc 22.2V 6S 4500~5200mAh Li-Po電池 x 2</p>	 <p>Receiver battery 7.4V 2S 1900~2300mAh Li Po x 1pc 接收機電池7.4V 2S 1900~2300mAh Li-Po x 1</p>	 <p>ESC (Li-Po 12S 80A or more) Li-Po 12S 80A以上ESC x 1</p>
 <p>Dial Pitch Gauge x 1pc 旋轉式螺距規 x 1</p>		

ADDITIONAL TOOLS REQUIRED FOR ASSEMBLY 自備工具

 <p>Scissors 剪刀</p>	 <p>Cutter Knife 刀子</p>	 <p>Diagonal Cutting Pliers 斜口鉗</p>	 <p>Needle Nose Pliers 尖嘴鉗</p>	
 <p>Oil 潤滑油</p>	 <p>CA 瞬間膠</p>	 <p>AB Glue AB膠</p>	 <p>Hexagon Screw Driver 六角螺絲起子 3mm/2.5mm/2mm/1.5mm</p>	 <p>Philips Screw Driver 十字螺絲起子 φ 3.0/ φ 1.8mm</p>

4.PACKAGE ILLUSTRATION 包裝說明

ALIGN

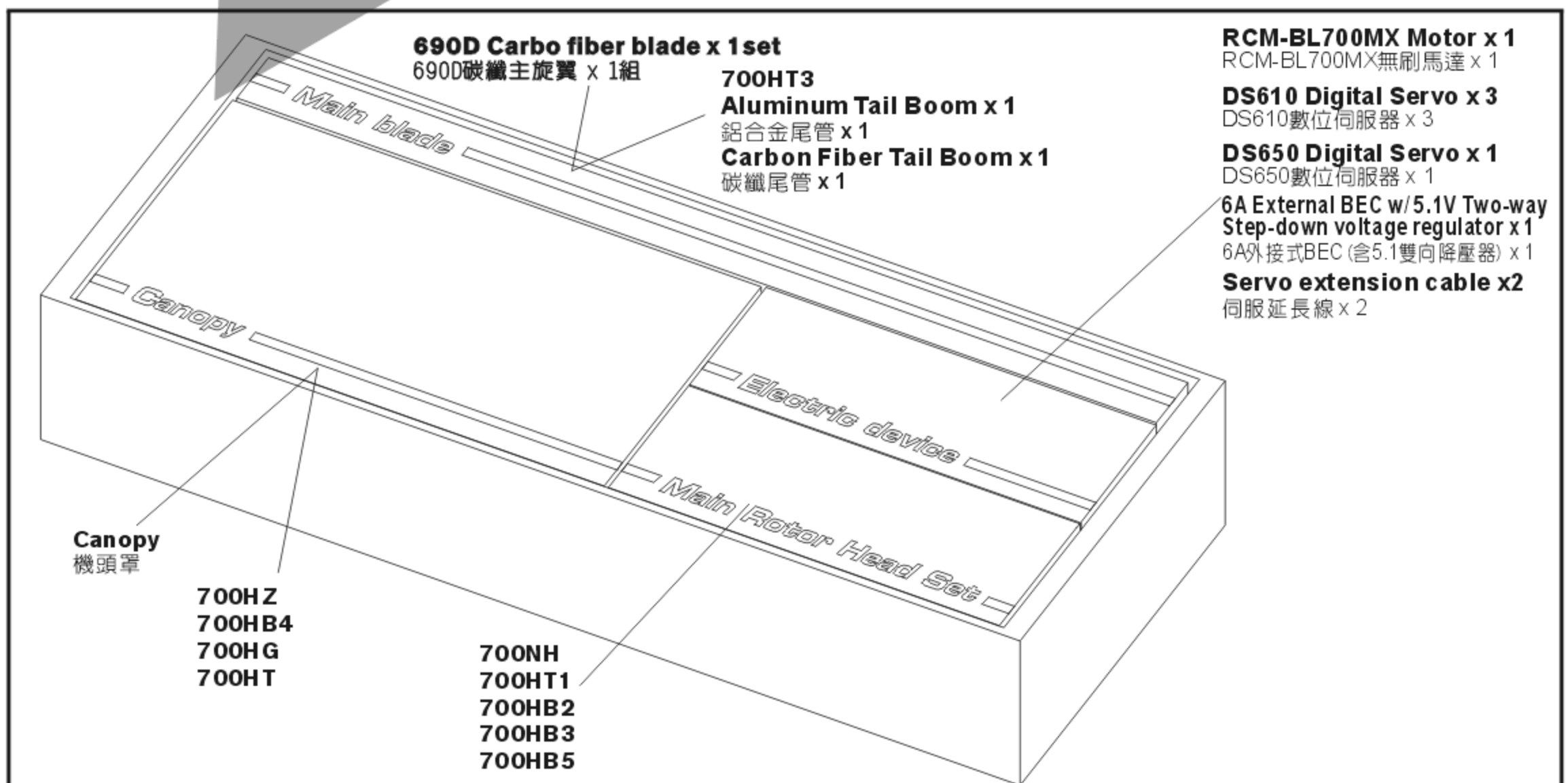

CAREFULLY INSPECT BEFORE REAL FLIGHT 請嚴格執行飛行前之檢查義務

- ☆ Before flying, please check to make sure no one else is operating on the same frequency for the safety.
- ☆ Before flight, please check if the batteries of transmitter and receiver are enough for the flight.
- ☆ Before turn on the transmitter, please check if the throttle stick is in the lowest position. IDLE switch is OFF.
- ☆ When turn off the unit, please follow the power on/off procedure. Power ON- Please turn on the transmitter first, and then turn on receiver. Power OFF- Please turn off the receiver first and then turn off the transmitter. Improper procedure may cause out of control, so please to have this correct habit.
- ☆ Before operation, check every movement is smooth and directions are correct. Carefully inspect servos for interference and broken gear.
- ☆ Check for missing or loose screws and nuts. See if there is any cracked and incomplete assembly of parts. Carefully check main rotor blades and rotor holders. Broken and premature failures of parts possibly cause resulting in a dangerous situation.
- ☆ Check all ball links to avoid excess play and replace as needed. Failure to do so will result in poor flight stability.
- ☆ Check if the battery and power plug are fastened. Vibration and violent flight may cause the plug loose and result out of control.
- ☆ Be sure to use the carbon fiber main rotor blades durable with 2800RPM(or faster) 690mm length. Please do not use the carbon fiber main rotor blades with durability lower than 2800RPM and wooden or glass fiber main blades to avoid any unpredictable damage.

- ★ 每次飛行前應先確認所使用的頻率是否會干擾他人，以確保你自身與他人的安全。
- ★ 每次飛行前確定您發射機與接收機電池的電量是在足夠飛行的狀態。
- ★ 開機前確認油門搖桿是否位於最低點，熄火降落開關，定速開關(IDLE)是否於關閉位置。
- ★ 關機時必須遵守電源開關機的程序，開機時應先開啓發射機後，再開啓接收機電源；關機時應先關閉接收機後，再關閉發射機電源。不正確的開關程序可能會造失控的現象，影響自身與他人的安全，請養成正確的習慣。
- ★ 開機請先確定直昇機的各個動作是否順暢，及方向是否正確，並檢查伺服器的動作是否有干涉或崩齒的情形，使用故障的伺服器將導致不可預期的危險。
- ★ 飛行前確認沒有缺少或鬆脫的螺絲與螺帽，確認沒有組裝不完整或損毀的零件，仔細檢查主旋翼是否有損壞，特別是接近主旋翼夾座的部位。損壞或組裝不完整的零件不僅影響飛行，更會造成不可預期的危險。注意：每次飛行前的安全檢查、保養、及更換損耗零件，請確實嚴格執行以確保安全。
- ★ 檢查所有的連桿頭是否有鬆脫的情形，過鬆的連桿頭應先更新，否則將造成直昇機無法操控的危險。
- ★ 確認電池及電源接頭是否固定牢靠，飛行中的震動或激烈的飛行，可能造成電源接頭鬆脫而造成失控的危險。
- ★ 主旋翼務必使用耐轉速2800RPM以上的 690mm長度碳纖維，嚴禁使用耐轉速低於2800RPM的碳纖維、玻纖維或木製槳。

Standard Equipment 標準配備

700HC1	700NH	700HB1	700HB2	700HB3	700HB4
CNC Main drive gear 700HB5	700HG	700HT	700HT1	700HT3	700HZ
690D Carbon Fiber Blades x1set 690D 碳纖維主旋翼 x1組	RCM-BL700MX510KV Brushless motor x1 RCM-BL700MX510KV 無刷馬達 x1	M4x4 Set Screw x2 M4x4 止洩螺絲 x2 Motor Pinion gear 12T x1 馬達齒輪 12T x1	DS610 Digital Servo x3 DS610 數位伺服器 x3 CNC Metal servo horn CNC 金屬伺服器舵角片 x3	GP780 Head Lock Gyro Combo x1 GP780 鎖定式陀螺儀組 (GP780+DS650) x1	6A External BEC w/5.1V Two-way Step-down voltage regulator 6A 外接式 BEC (含 5.1V 雙向降壓器)

When you see the marks as below, please use glue or grease to ensure flying safety.

標有以下符號之組裝步驟，請配合上膠或上油，以確保使用之可靠度。

- CA : Apply CA Glue to fix.
- AB : Apply AB Glue to fix.
- R48 : Apply Anaerobics Retainer to fix.
- T43 : Apply Thread Lock to fix.
- OIL : Add Grease.

- CA : 使用瞬間膠固定
- AB : 使用AB膠固定
- R48 : 使用金屬管狀固定缺氧膠固定
- T43 : 使用螺絲膠
- OIL : 添加潤滑油

When assembling ball links, make sure the "A" character faces outside.

各項塑膠製連桿頭扣接時，A字請朝外。



Grease
潤滑油



R48
綠色



T43
藍色



CA
Self-furnished
螺絲膠(自備)

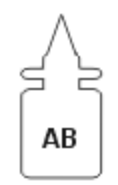

AB
Self-furnished
AB膠(自備)

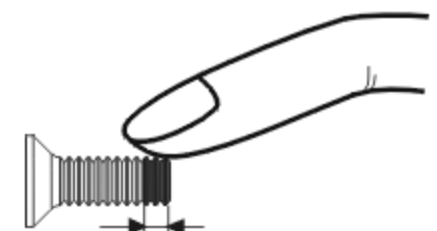

T43 Glue width : approx. 1mm
T43上膠寬度約1mm

R48 metal tubular adhesive (eg. Bearings). T43 thread lock, apply a small amount on screws or metal parts and wipe surplus off. When disassembling, recommend to heat the metal joint about 15 Seconds. (NOTE : Keep plastic parts away from heat.)

R48 為強力金屬管狀(如軸承)接著劑，T43為螺絲膠，膠合螺絲或金屬內外徑請務必少量使用，必要時請用手去除多餘膠量，欲拆卸時可於金屬接合部位熱烤約15秒。(注意！塑膠件避免接近熱源)

700NH1A

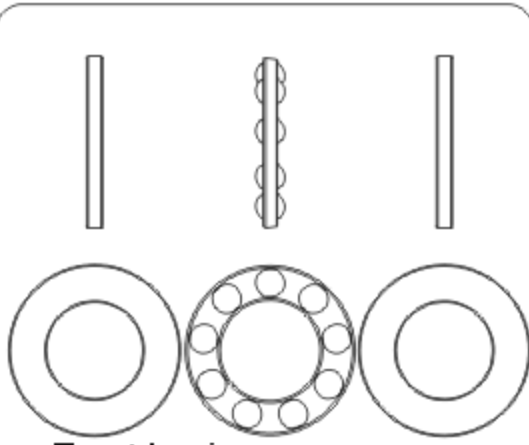

Thrust bearing
止推軸承(φ10.2xφ18x5.5mm) x 2

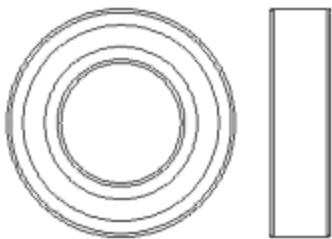

Bearing
軸承(φ10xφ19x5mm) x 2



Spindle bearing spacer
橫軸止推華司(φ10xφ16x1mm) x 2



Linkage ball A(M4x5)
球頭A(M4x5)(φ5x24mm) x 2

700NH1



Bearing
軸承(φ10xφ19x5mm) x 2

Apply a little amount of T43 thread lock when fixing a metal part.
螺絲鎖於金屬件請使用適量T43(螺絲膠)

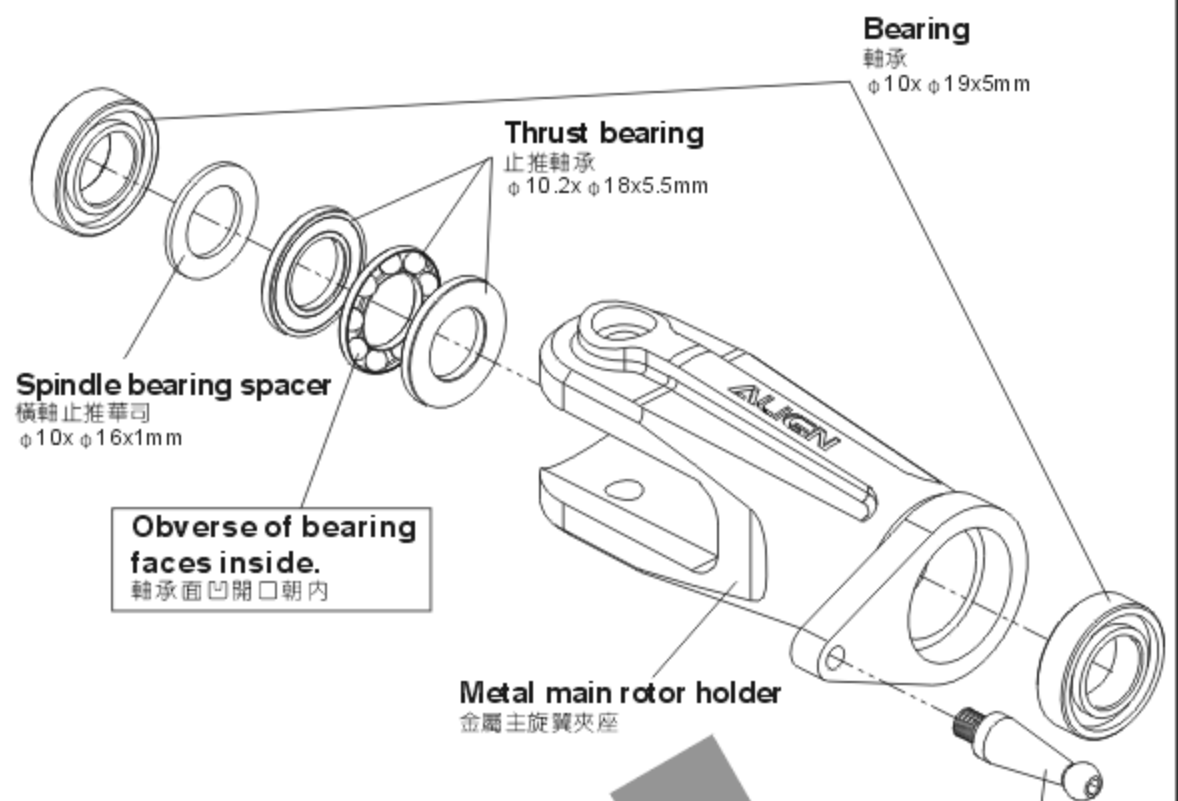

CAUTION 注意

Apply grease on thrust bearing.
止推軸承塗上潤滑油

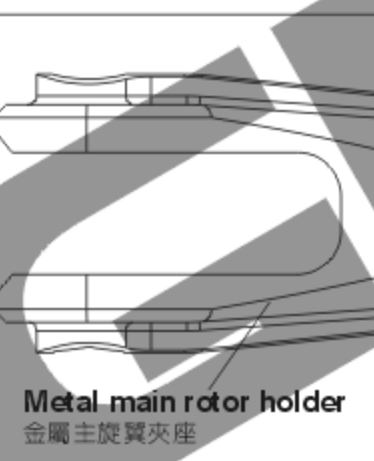
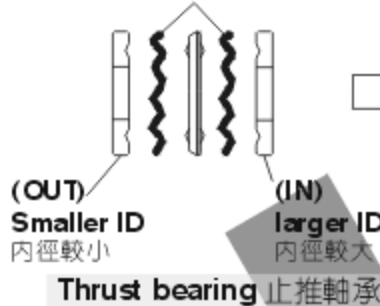

Linkage ball A(M4x5)
球頭A(M4x5) φ5x24mm

700NH1A



Spindle bearing spacer
橫軸止推華司(φ10xφ16x1mm) x 2

700NH2

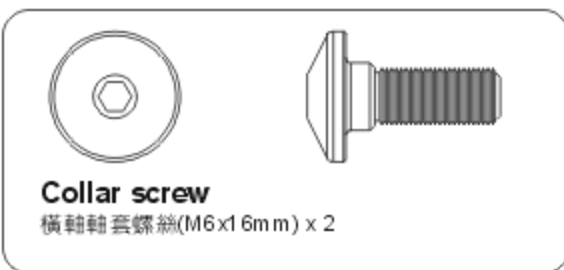

Collar screw
橫軸軸套螺絲(M6x16mm) x 2

700NH2A



Feathering shaft sleeve
橫軸套管(φ10.2xφ17x21mm) x 2

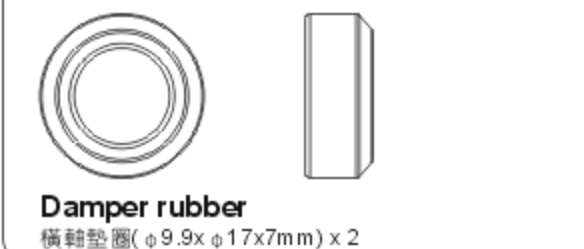

Damper rubber
橫軸墊圈(φ9.9xφ17x7mm) x 2

ALIGN Logo on the top 字樣朝上

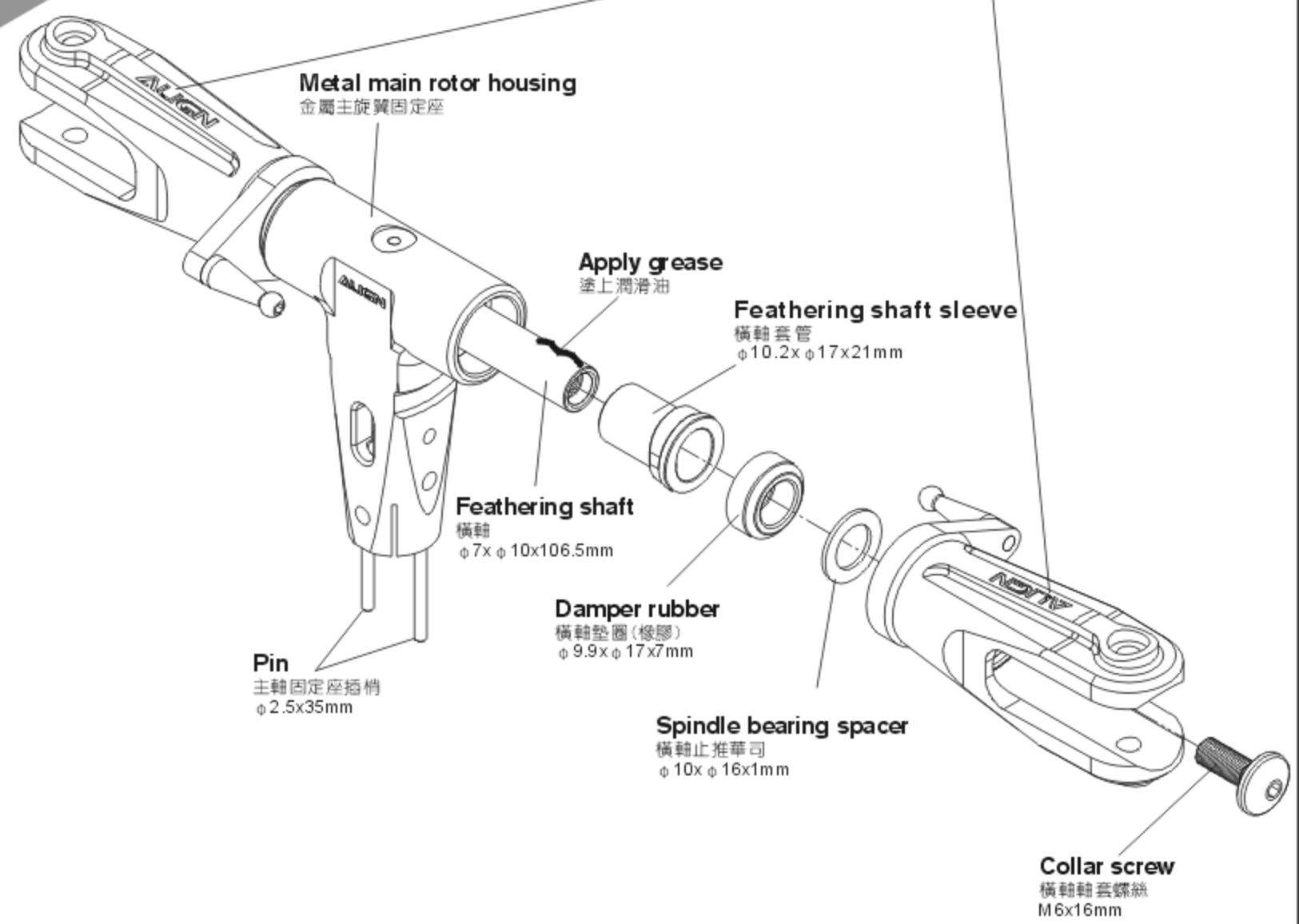

700NH2

Apply a little amount of T43 thread lock when fixing a metal part.
螺絲鎖附於金屬件請使用適量T43(螺絲膠)



Bearing
軸承(φ4xφ10x4mm) x 2



Bearing
軸承(φ3xφ7x3mm) x 4



Bearing
軸承(φ5xφ11.2xφ10x4mm) x 2



Collar
擺臂軸承襯套(φ3xφ4.8x1.5mm) x 2



Linkage ball C(M3x3.5)
球頭C(M3x3.5)(φ5x8.5mm) x 4



Socket button head screw
半圓頭內六角螺絲(M3x12mm) x 2



M4 collar screw
M4雙層軸套螺絲(M4x10mm) x 2



Washer
華司(φ3xφ4.8x0.3mm) x 4

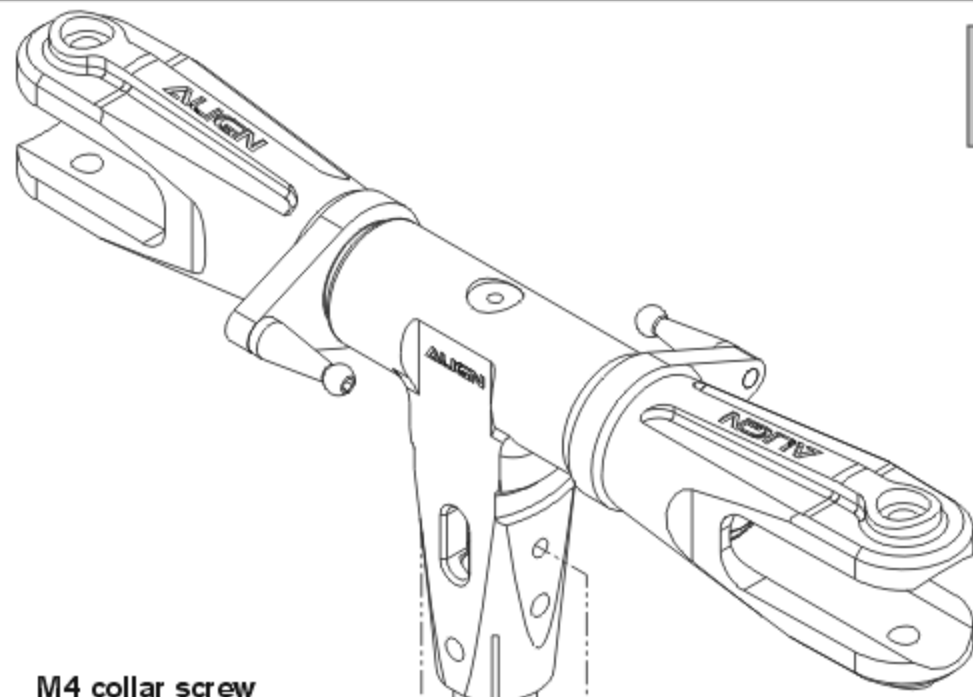

M4 collar screw
M4雙層軸套螺絲
M4x10mm

Metal flybar seesaw holder
金屬平衡桿固定座

Collar
擺臂軸承襯套
φ3xφ4.8x1.5mm

Bearing
軸承
φ3xφ7x3mm

Washer
華司
φ3xφ4.8x0.3mm

Socket button head screw
半圓頭內六角螺絲
M3x12mm

Bearing
軸承
φ4xφ10x4mm

Bearing
軸承
φ5xφ11.2xφ10x4mm

Washer
華司
φ3xφ4.8x0.3mm

Linkage ball C(M3x3.5)
球頭C(M3x3.5)
φ5x8.5mm

Metal SF Mixing arm
金屬SF控制搖臂

700NH3



Socket screw
圓頭內六角螺絲(M3x6mm) x 4



M4 Set screw
M4止洩螺絲(M4x4mm) x 2



Linkage rod(B)
連桿(B)(φ1.96x22mm) x 2



Ball link
連桿頭 x 4

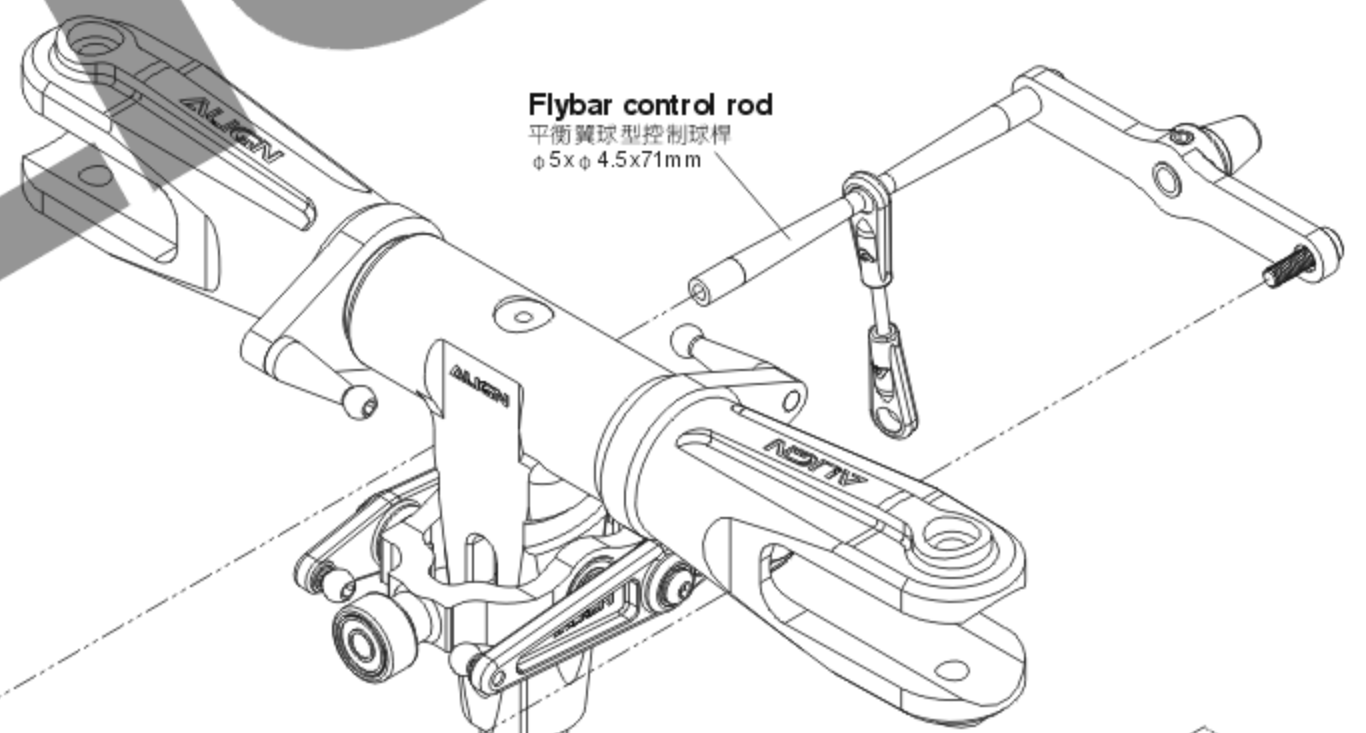

Flybar control rod
平衡翼球型控制球桿
φ5xφ4.5x71mm

Flybar rod
平衡桿
φ4x570mm

M4 Set screw
M4止洩螺絲
M4x4mm

Metal flybar control arm
金屬平衡翼控制臂

700HT4

Socket screw
圓頭內六角螺絲
M3x6mm

Assemble linkage rod (B) before assembling flybar control set.
組裝平衡翼控制組先將連桿裝入。

Linkage rod(B)
Approx. 45mm x 2
連桿(B)約45mm x 2

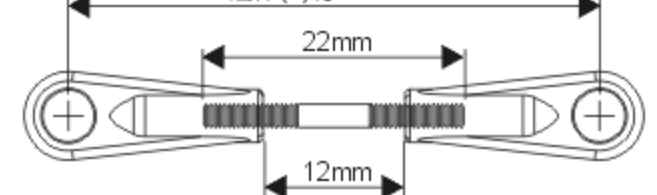

700NH4

Apply a little amount of T43 thread lock when fixing a metal part.
螺絲鎖附於金屬件請使用適量T43(螺絲膠)



Bearing
軸承(φ3xφ7x3mm) x 4



Bearing
軸承(φ2xφ5x2.3mm) x 4



Socket screw
圓頭內六角螺絲(M2x5mm) x 4



Socket button head screw
半圓頭內六角螺絲(M3x12mm) x 2



Washer
華司(φ3xφ4.8x0.3mm) x 4



Collar
擺臂軸承襯套(φ3xφ4.8x1.5mm) x 2

Socket screw
圓頭內六角螺絲
M4x8mm

Socket collar screw
圓頭內六角軸套螺絲
M4x24mm

Socket screw
圓頭內六角螺絲
M4x8mm

M4 Nut
M4防鬆螺帽
M4

Main shaft
主軸
φ8xφ12x212.5mm

3G Flybarless system uses 700FL Main shaft.
Standard Flybar system uses 700 Main shaft.
3G無平衡翼系統使用700FL主軸
有平衡翼系統使用標準700主軸

700NH4A



Linkage ball B(M3x4)
球頭B(M3x4)(φ5x12mm) x 2



Socket screw
圓頭內六角螺絲(M4x8mm) x 2



Socket collar screw
圓頭內六角軸套螺絲(M4x24mm) x 1



M4 Nut
M4防鬆螺帽 x 1

700NH5A



Linkage ball B(M3x4)
球頭B(M3x4)(φ5x12mm) x 7

Bearing
軸承
φ2xφ5x2.3mm

Socket screw
圓頭內六角螺絲
M2x5mm

Washer
華司
φ3xφ4.8x0.3mm

Metal washout base
金屬向位器

Collar
擺臂軸承襯套
φ3xφ4.8x1.5mm

Linkage ball B(M3x4)
球頭B(M3x4)
φ5x12mm

Radius arm
Radius連桿

Metal washout control arm
金屬穩定控制搖臂

Washer
華司
φ3xφ4.8x0.3mm

Bearing
軸承
φ3xφ7x3mm

Socket button head screw
半圓頭內六角螺絲
M3x12mm

Linkage ball B(M3x4)
球頭B(M3x4)
φ5x12mm

CAUTION
注意

Already assembled by Factory.
Before flying, please check if
the screws are fixed with glue.
原裝組裝完成品，每一次飛行前請
先確認螺絲是否已上膠不會鬆動。

700NH5

700HZ2

Linkage rod(A)
連桿(A) $\phi 1.96 \times 14\text{mm} \times 2$

Linkage rod(C)
連桿(C) $\phi 1.96 \times 56\text{mm} \times 2$

700HZ2A

Ball link
連桿頭 $\times 8$

700NH2A

Socket screw
圓頭內六角螺絲(M3x10mm) $\times 1$

M3 Set screw
M3止洩螺絲
M3x6mm

Flybar paddle
平衡翼

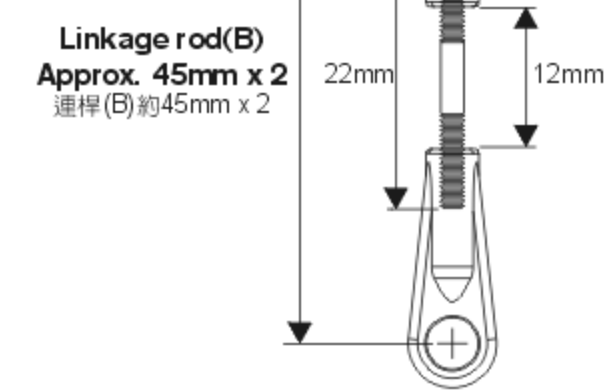
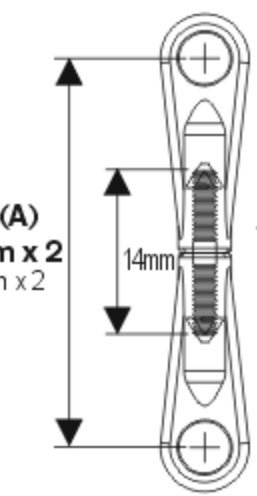

700NH3

M3 Set screw
M3止洩螺絲(M3x6mm) $\times 2$

Apply a little amount of T43 thread lock when fixing a metal part.
螺絲鎖附於金屬件請使用適量T43(螺絲膠)

Socket screw
圓頭內六角螺絲
M3x10mm

Head stopper
旋翼頭制動器

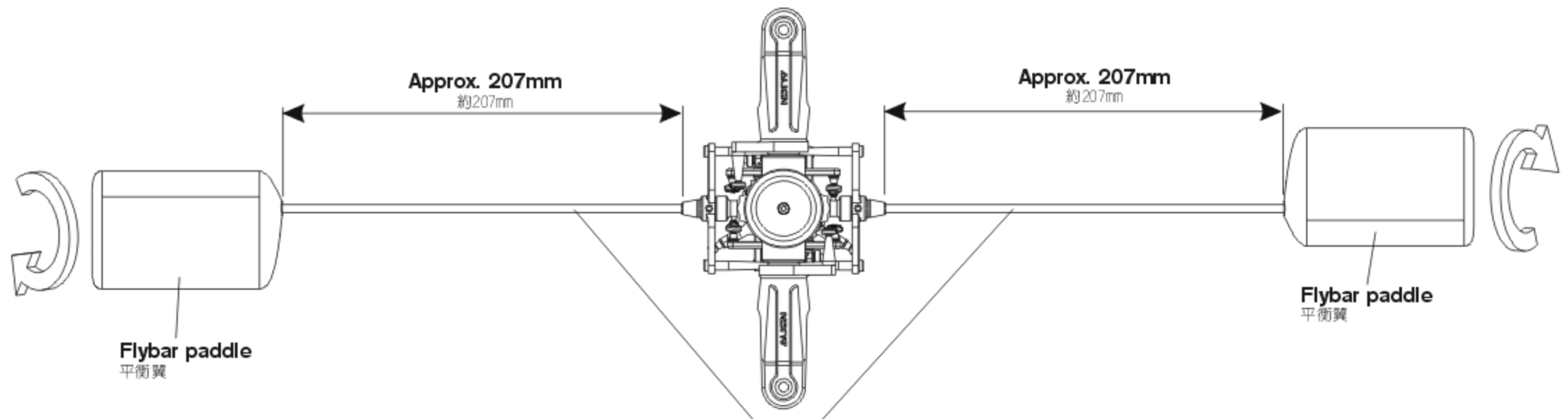

Make sure both sides are equal in length.
請保持平衡桿兩邊長度相等。

700HB3A



Frame mounting block
機身固定塊

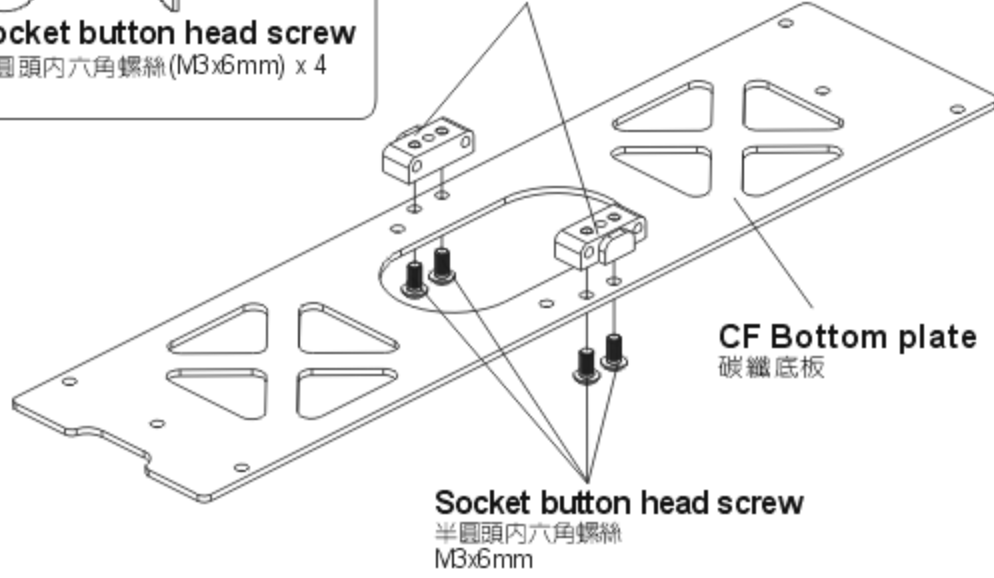

Socket button head screw
半圓頭內六角螺絲
M3x6mm

CF Bottom plate
碳纖維底板

700HZ4



Socket screw
圓頭內六角螺絲(M4x10mm) x 4



M4 Washer
M4華司(4x10x1mm) x 4



M4 Set screw
M4止洩螺絲(M4x4mm) x 2



CAUTION
注意
Make sure the motor mount is fully fastened before fasten the motor pinion gear mount.
先將馬達固定座鎖緊固定後，再將馬達齒座鎖緊。

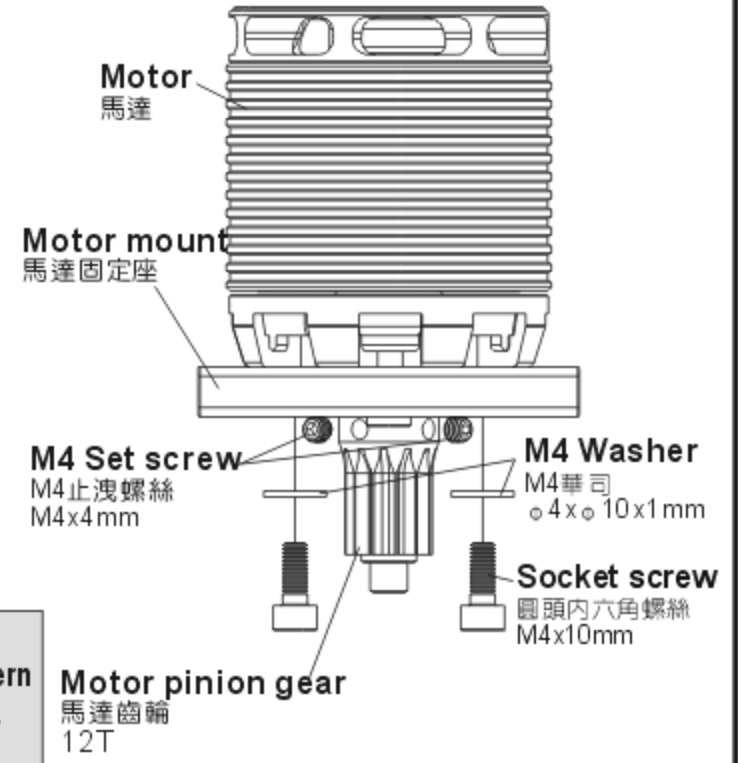

Motor
馬達

Motor mount
馬達固定座

M4 Set screw
M4止洩螺絲
M4x4mm

M4 Washer
M4華司
4x10x1mm

Socket screw
圓頭內六角螺絲
M4x10mm

Motor pinion gear
馬達齒輪
12T

700HB3

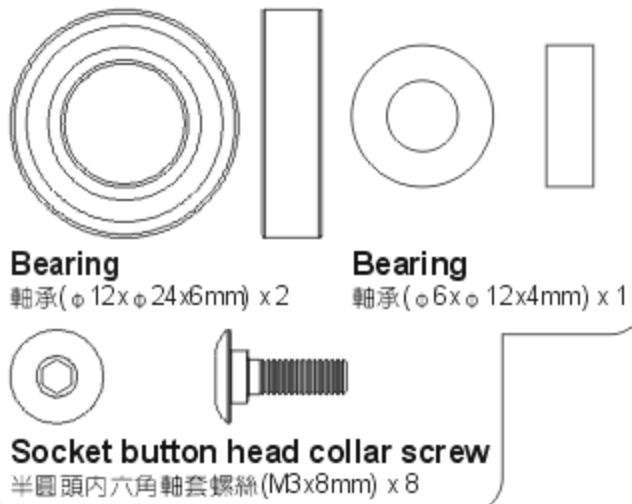

Bearing
軸承(φ12xφ24x6mm) x 2

Bearing
軸承(φ6xφ12x4mm) x 1

Socket button head collar screw
半圓頭內六角軸套螺絲(M3x8mm) x 8

700HB4A

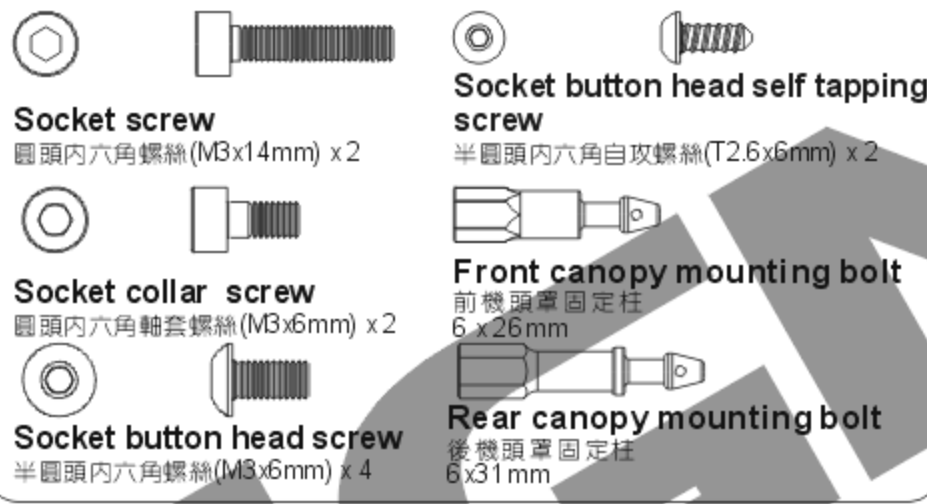

Socket screw
圓頭內六角螺絲(M3x14mm) x 2

Socket collar screw
圓頭內六角軸套螺絲(M3x6mm) x 2

Socket button head screw
半圓頭內六角螺絲(M3x6mm) x 4

Socket button head self tapping screw
半圓頭內六角自攻螺絲(T2.6x6mm) x 2

Front canopy mounting bolt
前機頭罩固定柱
6 x 26mm

Rear canopy mounting bolt
後機頭罩固定柱
6x31mm

700HB3A



Socket collar screw
圓頭內六角軸套螺絲(M3x6mm) x 18

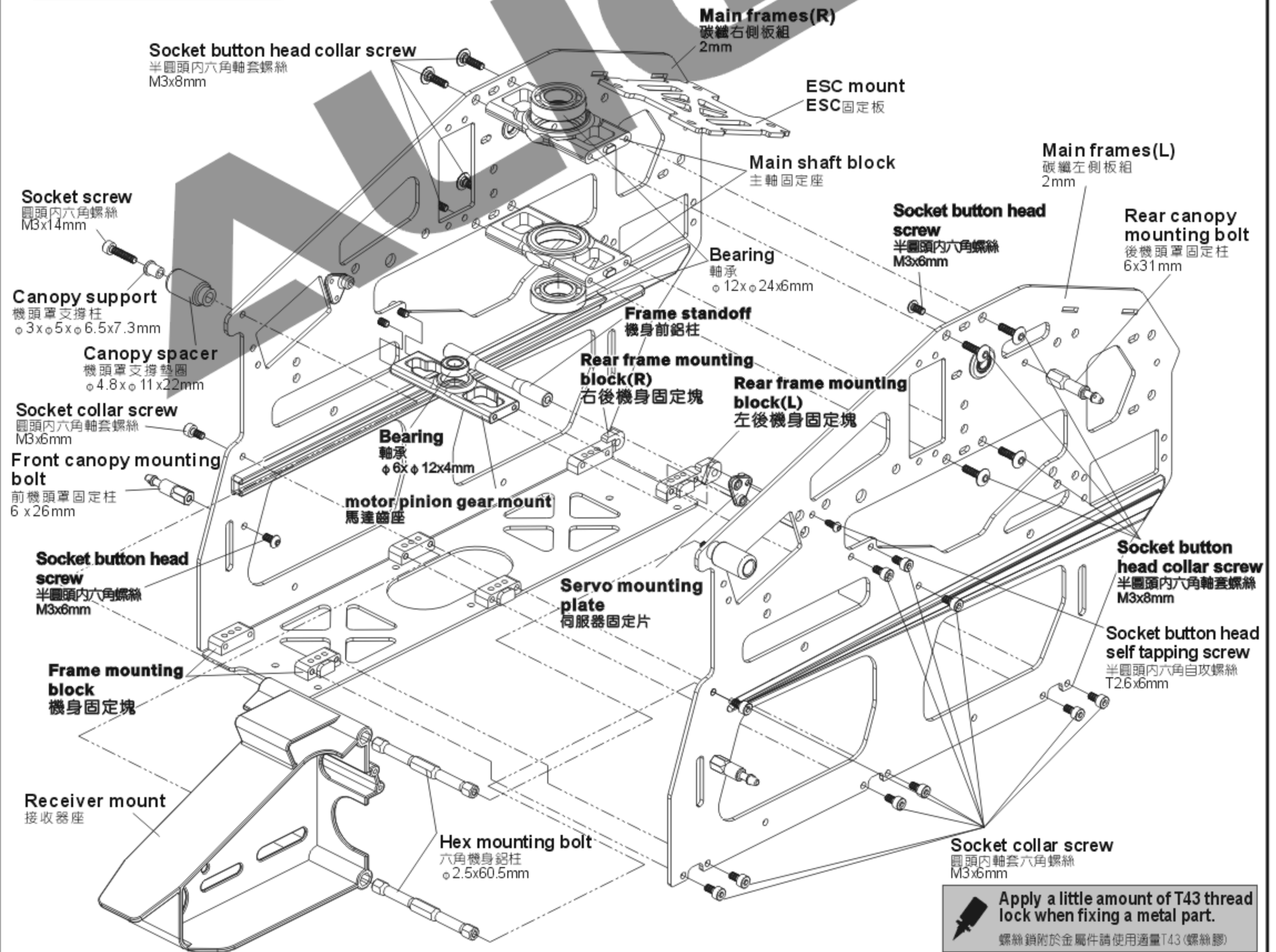

Main frames(R)
碳纖維右側板組
2mm

ESC mount
ESC固定板

Main shaft block
主軸固定座

Main frames(L)
碳纖維左側板組
2mm

Bearing
軸承
φ12xφ24x6mm

Socket button head screw
半圓頭內六角螺絲
M3x6mm

Rear canopy mounting bolt
後機頭罩固定柱
6x31mm

Socket screw
圓頭內六角螺絲
M3x14mm

Canopy support
機頭罩支撐柱
φ3xφ5xφ6.5x7.3mm

Canopy spacer
機頭罩支撐墊圈
φ4.8xφ11x22mm

Socket collar screw
圓頭內六角軸套螺絲
M3x6mm

Front canopy mounting bolt
前機頭罩固定柱
6 x 26mm

Socket button head screw
半圓頭內六角螺絲
M3x6mm

Frame mounting block
機身固定塊

Receiver mount
接收器座

Hex mounting bolt
六角機身鋁柱
φ2.5x60.5mm

Frame standoff
機身前鋁柱

Rear frame mounting block(R)
右後機身固定塊

Rear frame mounting block(L)
左後機身固定塊

Bearing
軸承
φ6xφ12x4mm

motor pinion gear mount
馬達齒座

Servo mounting plate
伺服器固定片

Socket button head collar screw
半圓頭內六角軸套螺絲
M3x8mm

Socket button head self tapping screw
半圓頭內六角自攻螺絲
T2.6x6mm

Socket collar screw
圓頭內六角軸套螺絲
M3x6mm

Apply a little amount of T43 thread lock when fixing a metal part.
螺絲鎖附於金屬件時請使用適量T43(螺絲膠)

Main frame assembly key point :

First do not fully tighten the screws of main frames and put two bearings through the main shaft to check if the movements are smooth. The bottom bracket must be firmly touched the level table top(glass surface) : please keep the smooth movements on main shaft and level bottom bracket, then slowly tighten the screws.

This assembly can help for the power and flight performance.

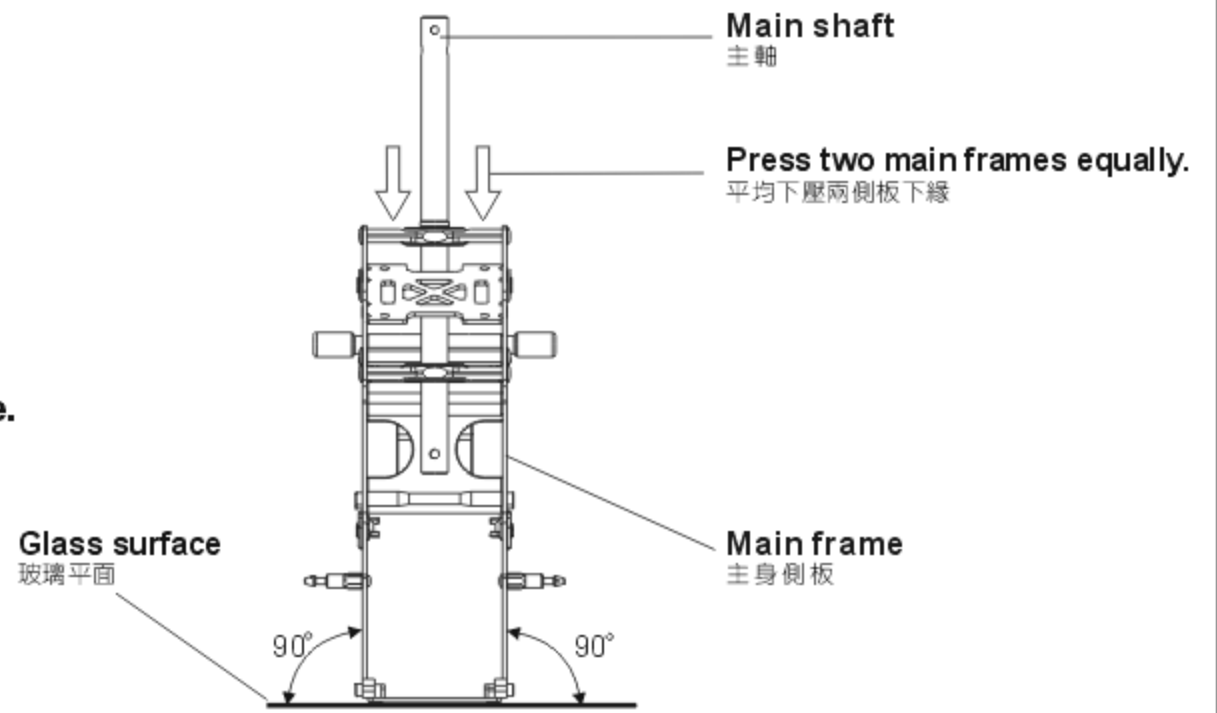

機身側板組立重點：

側板螺絲先不完全鎖緊，放入主軸貫穿二顆軸承確認上下移動必需滑順，主體底板必須與水平桌面（玻璃平面）踏實緊貼：請保持主軸滑順與底板平行桌面後慢慢鎖緊螺絲。正確側板的組裝對動力與飛行性能有顯著幫助。



700HG1A

Apply a little amount of T43 thread lock when fixing a metal part.
螺絲鎖附於金屬件請使用適量T43(螺絲膠)

-  **Socket screw**
圓頭內六角螺絲(M3x10mm) x 4
-  **M3 Washer**
M3華司(φ3xφ8x1mm) x 4
-  **M3 Set screw**
M3止洩螺絲(M3x4mm) x 4

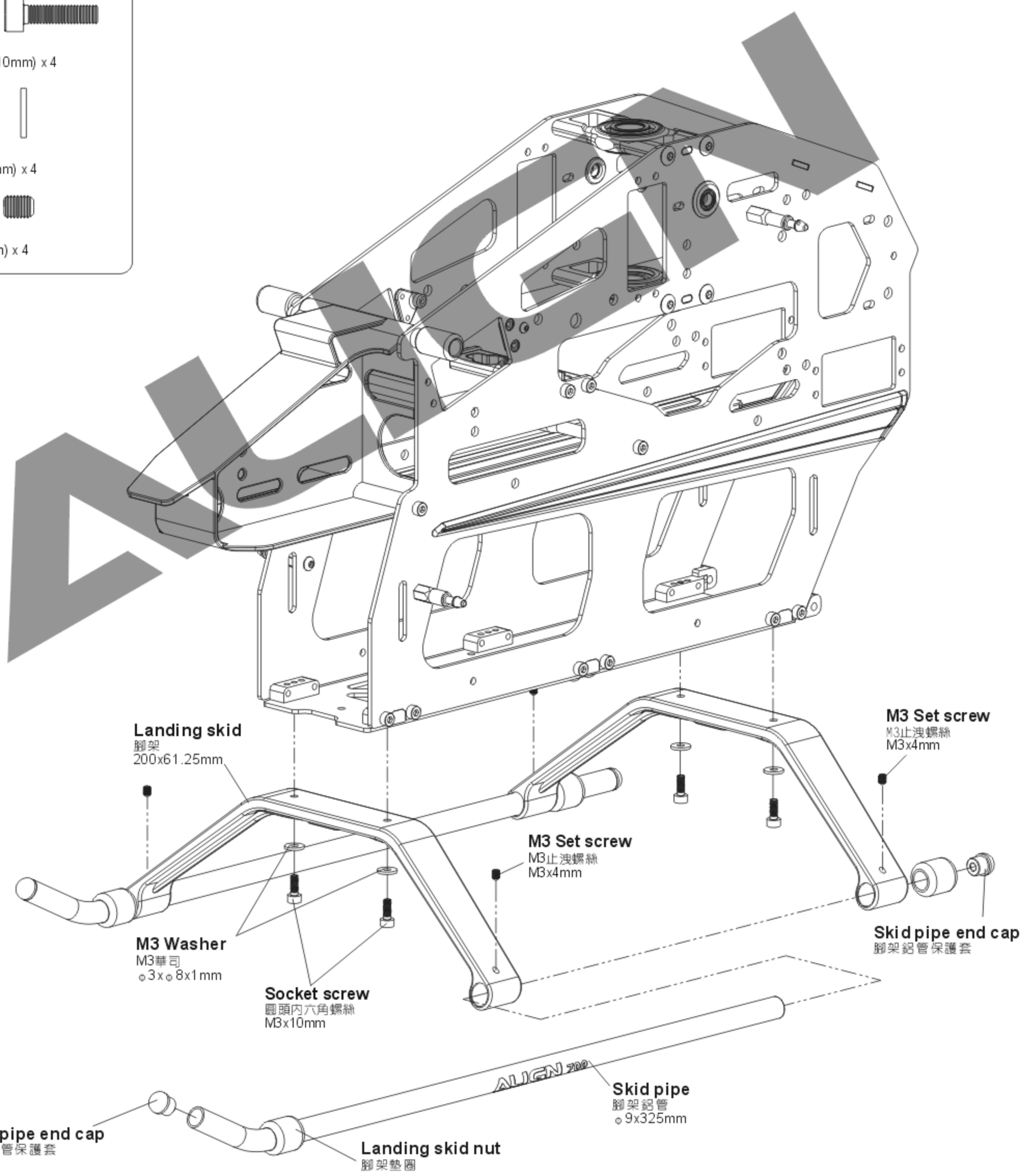

700HZ5

- Linkage ball C (M2x4)**
球頭C (M2x4) (φ5x9mm) x 4
- Socket button head self tapping screw**
半圓頭內六角自攻螺絲 (T2.6x12mm) x 12
- M2 Nut**
M2螺帽 x 4

Apply a little amount of T43 thread lock when fixing a metal part.
螺絲鎖附於金屬件請使用適量T43(螺絲膠)

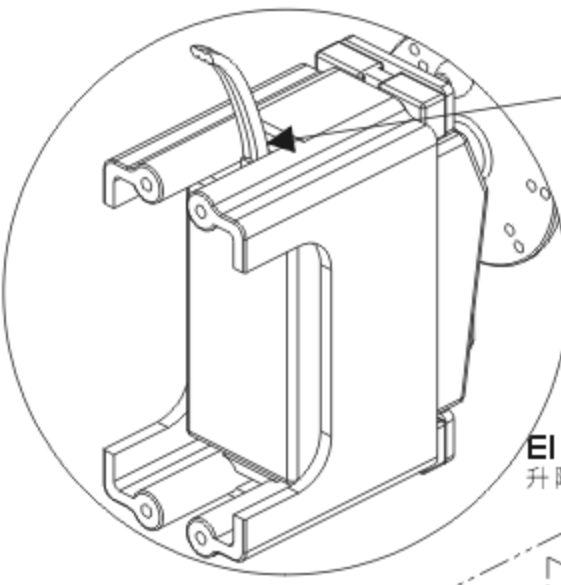

To avoid crimping the elevator servo wire, position the servo so that wire exit is at the side with the deeper hole in the servo mounting cage.
安裝伺服器時，請將訊號線出線口對準升降伺服器座較深缺口的一側，避免擠壓訊號線。

Elevator servo mount
升降伺服器座

DS610 Servo
DS610伺服器

Socket button head self tapping screw
半圓頭內六角自攻螺絲
T2.6x12mm

Linkage ball C (M2x4)
球頭C (M2x4)
φ5x9mm

CNC Metal servo horn
CNC金屬伺服器舵角片

M2 Nut
M2螺帽

3K CF servo plate
3K碳纖維伺服器壓片

CAUTION
注意

3G Flybarless system uses inner hole (A)
Flybar system uses outer hole (B)
3G無平衡翼系統使用內孔(A)
有平衡翼系統使用外孔(B)

CNC Metal servo horn
CNC金屬伺服器舵角片

Use the outer hole
請鎖附於外孔

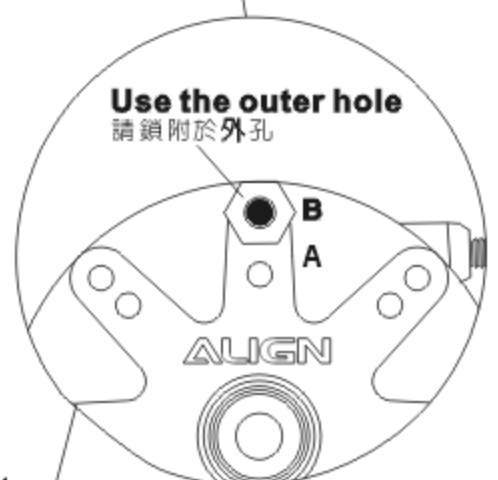

F servo horns :
Compatible with Align DS6xx series and Futaba servos.

F伺服器舵角片：
適用於亞拓DS6系列伺服器及Futaba伺服器。

3K CF servo plate
3K碳纖維伺服器壓片

Linkage ball C (M2x4)
球頭C (M2x4)
φ5x9mm

CNC Metal servo horn
CNC金屬伺服器舵角片

M2 Nut
M2螺帽

Socket button head self tapping screw
半圓頭內六角自攻螺絲
T2.6x12mm

DS610 Servo
DS610伺服器

DS610 Digital Servo :

- 1.1520 μs standard band / 1520 μs 寬頻系統
- 2.Stall torque/輸出扭力 : 9.6kg.cm(4.8V)
12.0kg.cm(6.0V)
- 3.Motion speed/動作速度 : 0.10sec/60° (4.8V)
0.08sec/60° (6.0V)
- 4.Dimension/尺寸 : 40.3 x 20.1 x 36mm
- 5.Weight/重量 : 52.2g

700HZ5

Linkage ball C(M2x4)
球頭C(M2x4)(ϕ 5x9mm) x 3

Socket button head self tapping screw
半圓頭內六角自攻螺絲(T2.6x12mm) x 12

M2 Nut
M2螺帽 x 3

700HB3A

Socket button head collar screw
半圓頭內六角軸套螺絲(M3x8mm) x 4

Recommend sanding the marked position as below illustration with a waterproof abrasive paper(#800-1000) to avoid the wires of electric parts to be cut.

建議於下圖色塊標示處，使用#800-1000水砂紙打磨，可防止電子設備電線被割破。

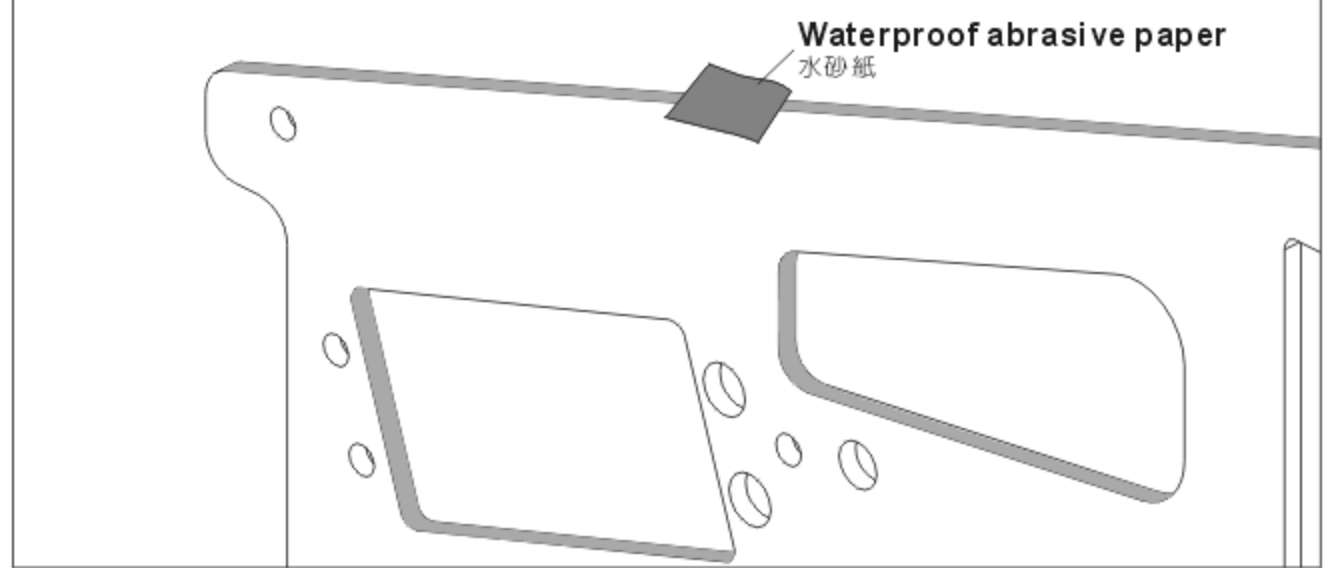

Waterproof abrasive paper
水砂紙

CAUTION
注意

Make sure the motor mount is fully fastened before fasten the motor pinion gear mount.
先將馬達固定座鎖緊固定後，再將馬達齒座鎖緊。

Motor
馬達

DS610 Digital Servo :

1. 1520 μ s standard band / 1520 μ s 寬頻系統
2. Stall torque/輸出扭力 : 9.6kg.cm(4.8V)
12.0kg.cm(6.0V)
3. Motion speed/動作速度 : 0.10sec/60° (4.8V)
0.08sec/60° (6.0V)
4. Dimension/尺寸 : 40.3 x 20.1 x 36mm
5. Weight/重量 : 52.2g

DS610 Servo
DS610伺服器

Socket button head collar screw
半圓頭內六角軸套螺絲
M3x8mm

3K CF servo plate
3K碳纖維伺服器壓片

Socket button head self tapping screw
半圓頭內六角自攻螺絲
T2.6x12mm

Socket button head collar screw
半圓頭內六角軸套螺絲
M3x8mm

Socket button head self tapping screw
半圓頭內六角自攻螺絲
T2.6x12mm

Elevator servo mount
尾舵伺服器座

Linkage ball C(M2x4)
球頭C(M2x4)
 ϕ 5x9mm

3K CF servo plate
3K碳纖維伺服器壓片

M2 Nut
M2螺帽

Socket button head self tapping screw
半圓頭內六角自攻螺絲
T2.6x12mm

Linkage ball C(M2x4)
球頭C(M2x4)
 ϕ 5x9mm

M2 Nut
M2螺帽

CNC Metal servo horn
CNC金屬伺服器舵角片

Use the outer hole
請鎖附於外孔

DS650 Servo
DS650伺服器

DS650 Digital Servo :

1. 1520 μ s standard band / 1520 μ s 寬頻系統
2. Stall torque/輸出扭力 : 4.0kg.cm(4.8V)
5.0kg.cm(6.0V)
3. Motion speed/動作速度 : 0.058sec/60° (4.8V)
0.048sec/60° (6.0V)
4. Dimension/尺寸 : 40.3 x 20.1 x 36mm
5. Weight/重量 : 56g

Servo extension cable
伺服器延長線

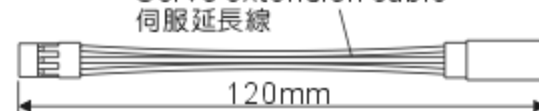

For extend the rudder servo signal cable.
尾舵伺服器訊號線延長用

CAUTION
注意

3G Flybarless system uses inner hole(A)
Flybar system uses outer hole(B)
3G無平衡翼系統使用內孔(A)
有平衡翼系統使用外孔(B)

Apply a little amount of T43 thread lock when fixing a metal part.
螺絲鎖附於金屬件請使用適量T43(螺絲膠)

700HB3



Bearing
軸承(φ5xφ9x3mm) x 4



Socket button head screw
半圓頭內六角螺絲(M3x6mm) x 2



Socket button head screw
半圓頭內六角螺絲(M3x8mm) x 2



Bearing
軸承(φ3xφ7x3mm) x 2



M4 Set screw
M4止洩螺絲(M4x4mm) x 1



Control shaft collar
運動桿套圈(φ5xφ7.5x3mm) x 2



Collar
升降運動控制臂軸套
(φ3xφ4.5x1.5mm) x 2

700HB3A



Linkage ball C(M3x3.5)
球頭C(M3x3.5)(φ5x8.5mm) x 6

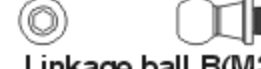

Linkage ball B(M3x4)
球頭B(M3x4)(φ5x12mm) x 2



Socket screw
圓頭內六角螺絲(M3x8mm) x 1



Washer
華司(φ3xφ5.5x0.3mm) x 2



Washer
華司(φ5xφ7x0.2mm) x 2



Washer
華司(φ5xφ7x0.5mm) x 2

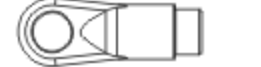

Elevator ball link
升降臂連桿頭



CAUTION
注意
Please fasten the elevator ball link and screws all the way in.
升降臂連桿頭及螺絲請鎖緊。

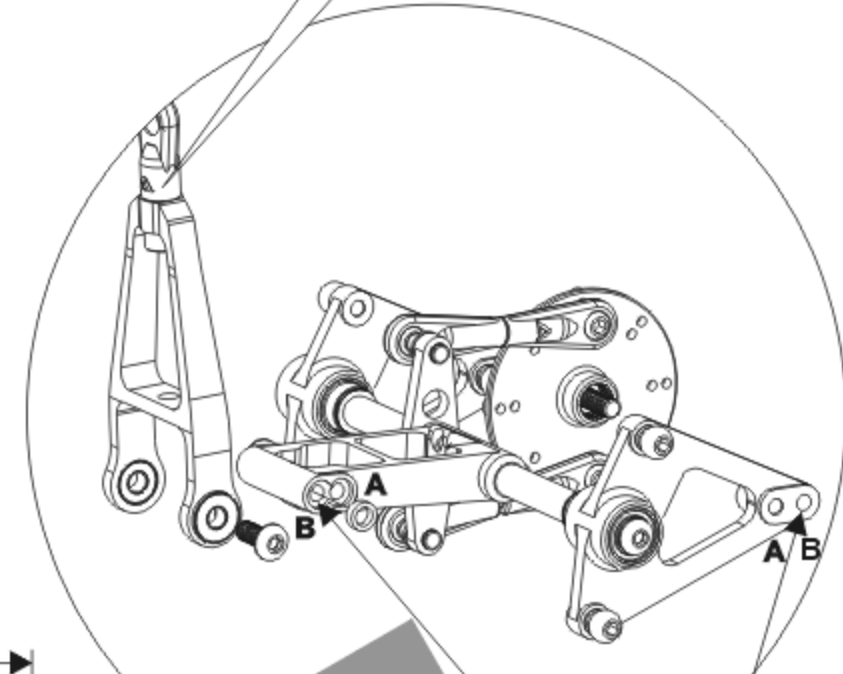
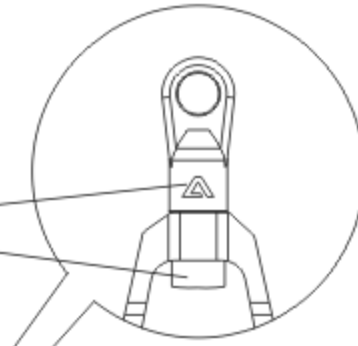

Linkage rod(E)
Approx. 35mm x 2
連桿(E)約35mm x 2

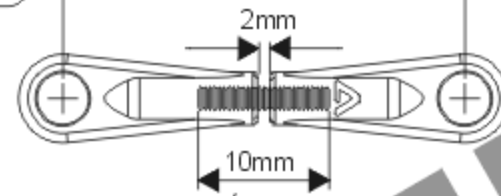

CAUTION
注意
3G Flybarless system uses inner hole(A)
Flybar system uses outer hole(B)
3G無平衡翼系統使用內孔(A)
有平衡翼系統使用外孔(B)

700HZ2



Linkage rod(E)
連桿(E) φ1.96x10mm x 2

Elevator ball link
升降臂連桿頭

Elevator arm
升降控制臂

Socket screw
圓頭內六角螺絲
M3x8mm

Bearing
軸承
φ3xφ7x3mm

Linkage ball B(M3x4)
球頭B(M3x4)
φ5x12mm

M4 Set screw
M4止洩螺絲
M4x4mm

Elevator lever
升降運動控制臂

Collar
升降運動控制臂軸套
φ3xφ4.5x1.5mm

Socket button head screw
半圓頭內六角螺絲
M3x6mm

Washer
華司
φ3xφ5.5x0.3mm

Linkage ball C(M3x3.5)
球頭C(M3x3.5)
φ5x8.5mm

Control shaft collar
運動桿套圈
φ5xφ7.5x3mm

Washer
華司
φ5xφ7x0.5mm

Washer
華司
φ5xφ7x0.2mm

Washer spare for gap adjustment.
間隙調整用華司

Control shaft
運動桿
φ4.7xφ5x98mm

Washer spare for gap adjustment.
間隙調整用華司

Washer
華司
φ5xφ7x0.5mm

Linkage ball C(M3x3.5)
球頭C(M3x3.5)
φ5x8.5mm

Aileron lever
左右控制搖臂

Washer
華司
φ3xφ5.5x0.3mm

Bearing
軸承
φ5xφ9x3mm

Socket button head screw
半圓頭內六角螺絲
M3x6mm

Control shaft collar
運動桿套圈
φ5xφ7.5x3mm

Apply a little amount of T43 thread lock when fixing a metal part.
螺絲鎖附於金屬件請使用適量T43(螺絲膠)

700HZ2

700HZ2A

◎ □
Aileron Control rod Carbon Fiber Shaft
 升降控制連桿碳纖套 (φ4xφ5.4x6.5mm) x 8

◎ ————
Aileron Control rod Carbon Fiber Tube
 升降控制連桿碳纖管 (φ2.2xφ3.9x96mm) x 4

○ ————
Linkage rod(F)
 連桿(F) φ1.96x110mm x 4



Ball link
 連桿頭 x 8

Aileron Carbon Fiber Linkage Rod Set 副翼控制碳纖連桿組要領

Put on AB Glue
 塗上AB膠



- 1: Mix thoroughly suitable amount of epoxy.
- 2: Apply generous amount of epoxy on the tips of carbon tube after sliding over the linkage rod. (Suggest to use the AB glue that hardened in 30 mins.)
 (Note: for quick drying epoxy, work fast as it must be applied prior to curing)

1: 使用適量的AB膠,並且均勻的攪拌混合
 2: 將已套入連桿的碳纖管兩端塗上AB膠(建議使用30分鐘硬化的AB膠)
 (注意若使用速乾型AB膠請務必於膠乾固前組裝完成)



- 3: Slide the carbon end caps on both sides of the carbon tube.

3: 接著將碳纖套分別套入碳纖管兩端



- 4: Thread the ball links onto the linkage rod until the base to base length is 97.5mm.

4: 將連桿頭鎖入連桿至跨距為97.5mm的位置



- 5: If gap exists between the ball link and end caps after correct length has been achieved, slide the end caps outwards to cover the gaps
 (note: must be done before epoxy cures)

- 6: Wipe away excess epoxy and set it aside to cure.

5: 碳纖套與連桿頭會有些許的間隙,此時請將碳套往兩側推至切齊連桿頭
 (注意:須在AB膠未乾固時完成此動作)
 6: 將多餘的殘膠擦拭乾淨後請靜置AB膠乾固方可使用

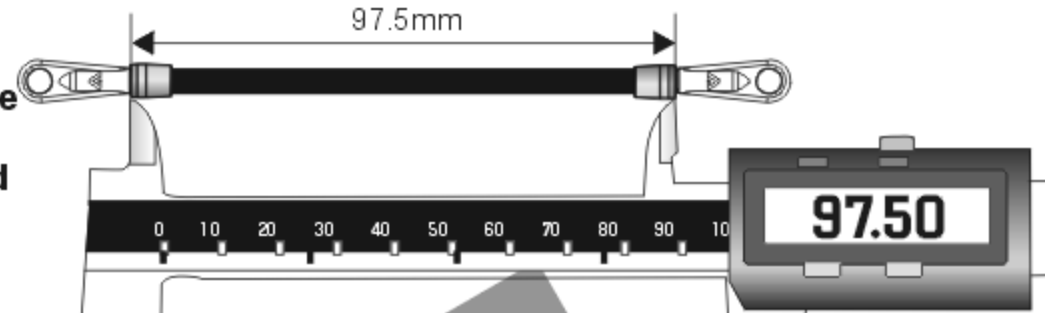

Ball link
 連桿頭

Linkage rod(F)
 連桿(F) φ1.96x110mm

Aileron Control rod Carbon Fiber Shaft
 升降控制連桿碳纖套

Aileron Control rod Carbon Fiber Tube
 升降控制連桿碳纖管

Linkage rod(F)
 Approx. 130.5mm x 4
 連桿(F)約130.5mm x 4

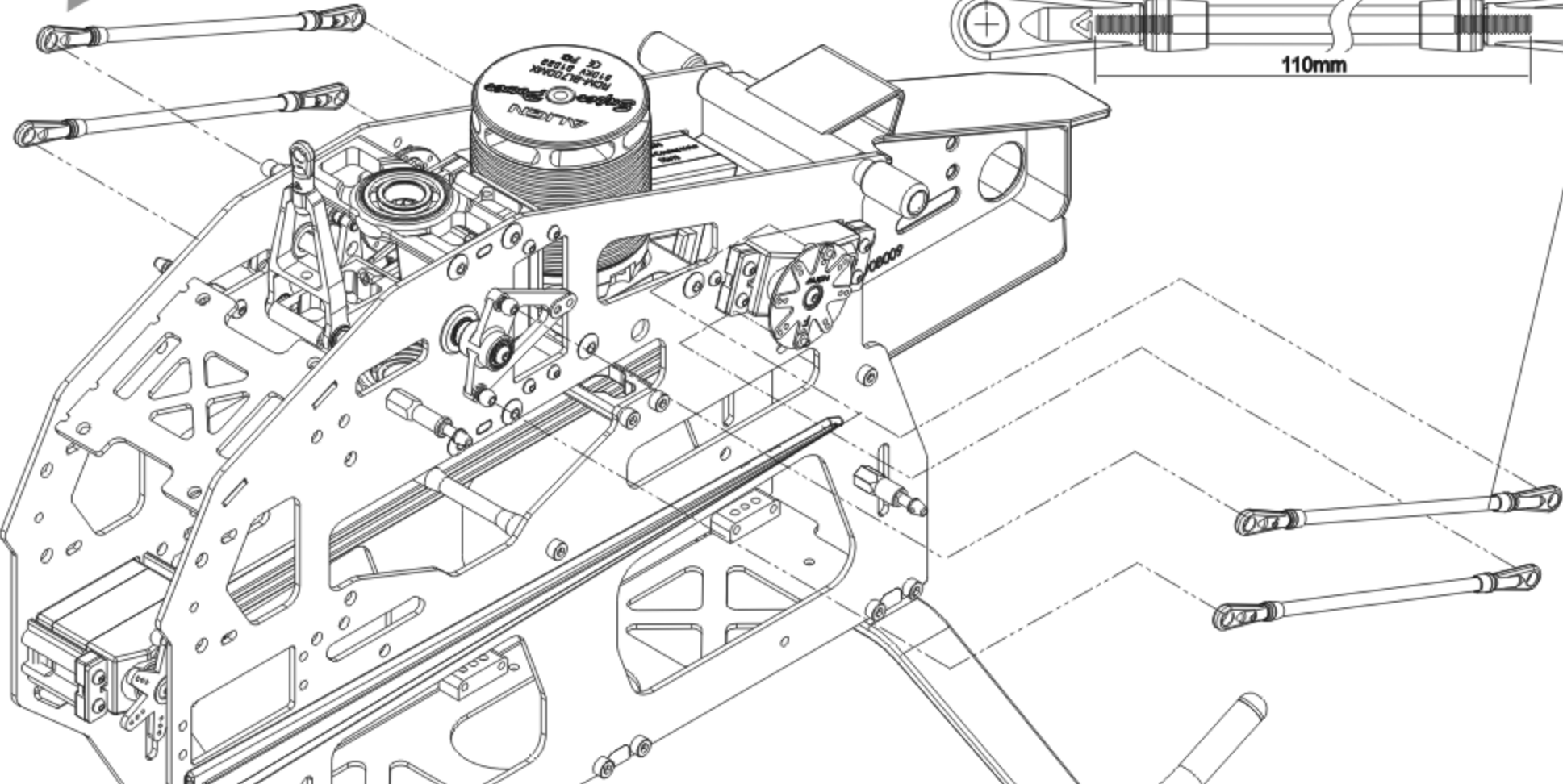

700HT1

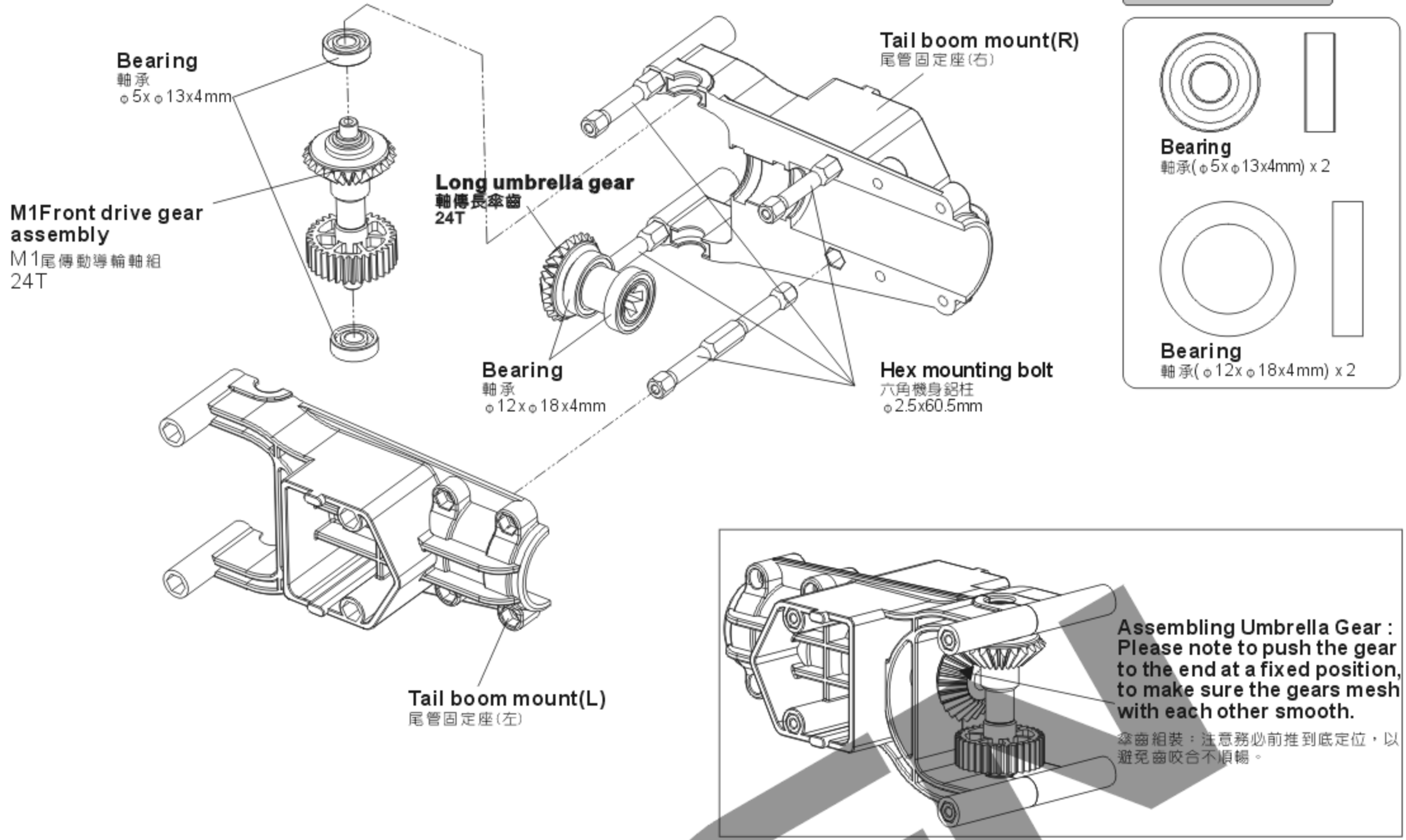

700NT2A

Apply a little amount of T43 thread lock when fixing a metal part.
螺絲鎖附於金屬件請使用適量T43(螺絲膠)

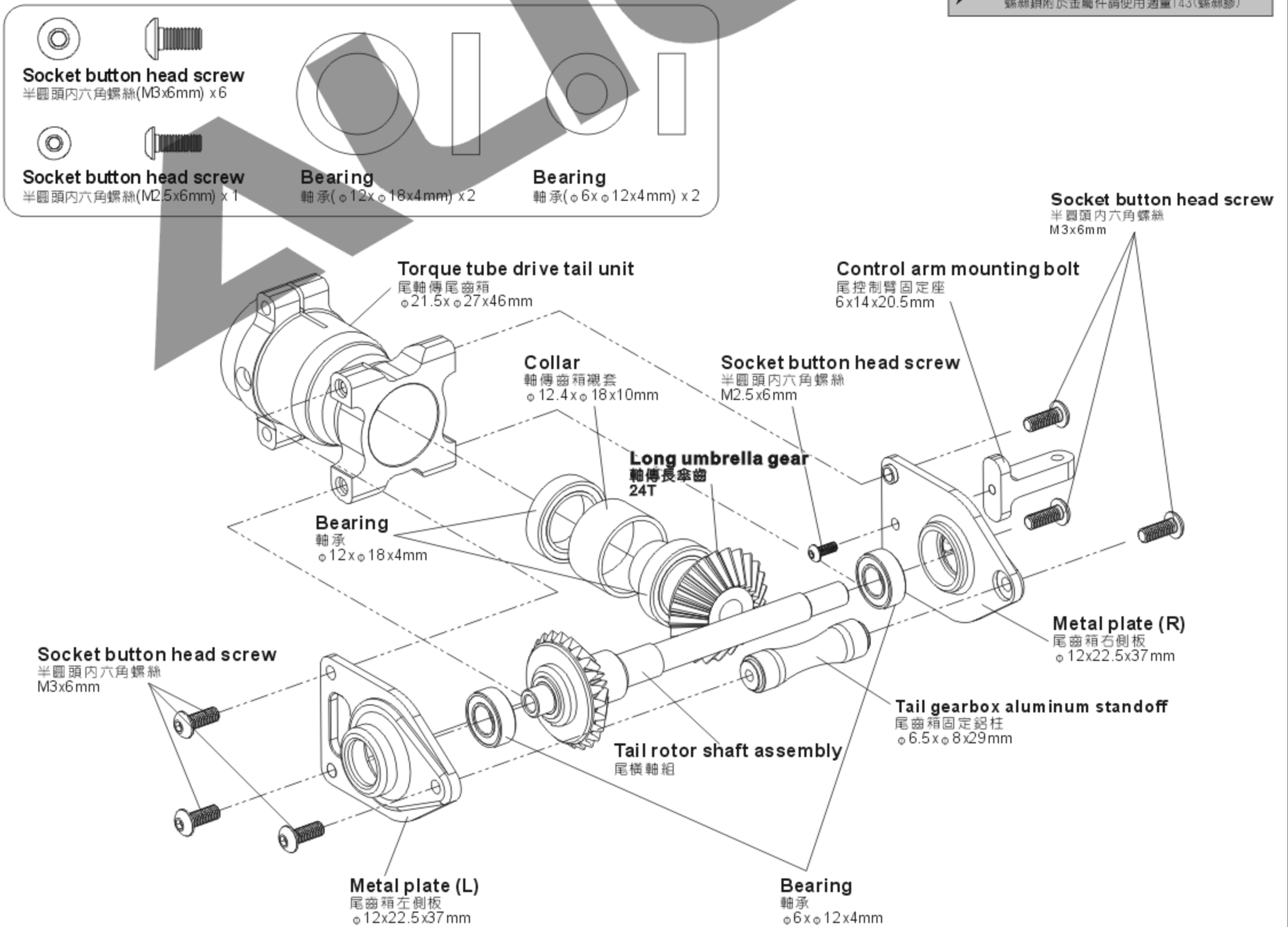

700NT2F

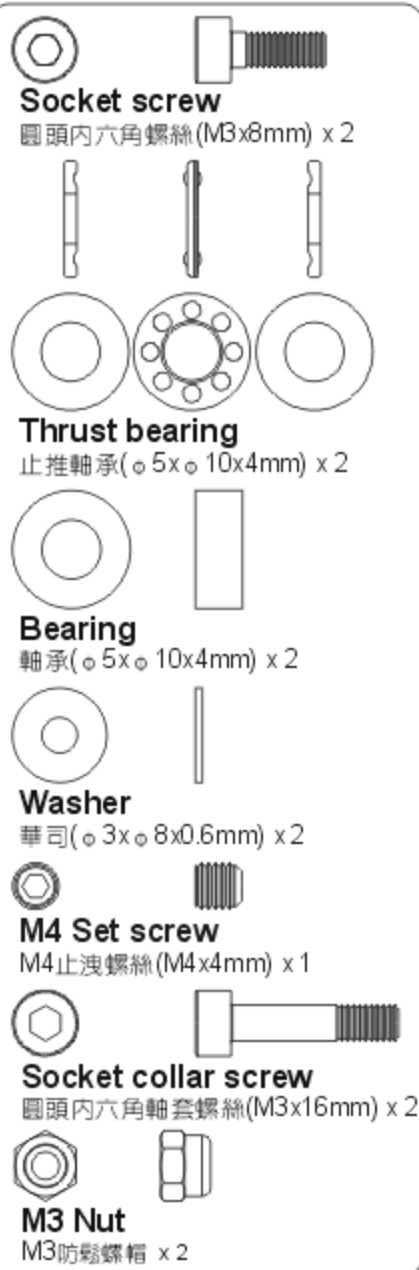

700NT2C



700NT2D



Apply a little amount of T43 thread lock when fixing a metal part.
螺絲鎖附於金屬件請使用適量T43(螺絲膠)



While assembly the slide shaft, please use suitable amount of T43 on the thread. Please do not use R48 anaerobics retainer or other high strength glue to avoid damages while maintenance or repairs.
組立尾軸滑套時，請使用適量的T43螺絲膠在螺牙上，嚴禁使用R48高膠合性軸承膠防止膠合過緊，以避免日後拆修維護零件之損傷。



Aim tail rotor hub at the concave of tail rotor shaft and fix it, please apply a little glue on the set screw.
尾旋翼T型座瞄準尾橫軸的凹刻並鎖上，請確認止洩螺絲上膠。

Assembling Umbrella Gear: Please note to push the gear to the end at a fixed position, to make sure the gears mesh with each other smoothly.
傘齒相裝：注意務必前推到底定位，以免齒咬合不順。

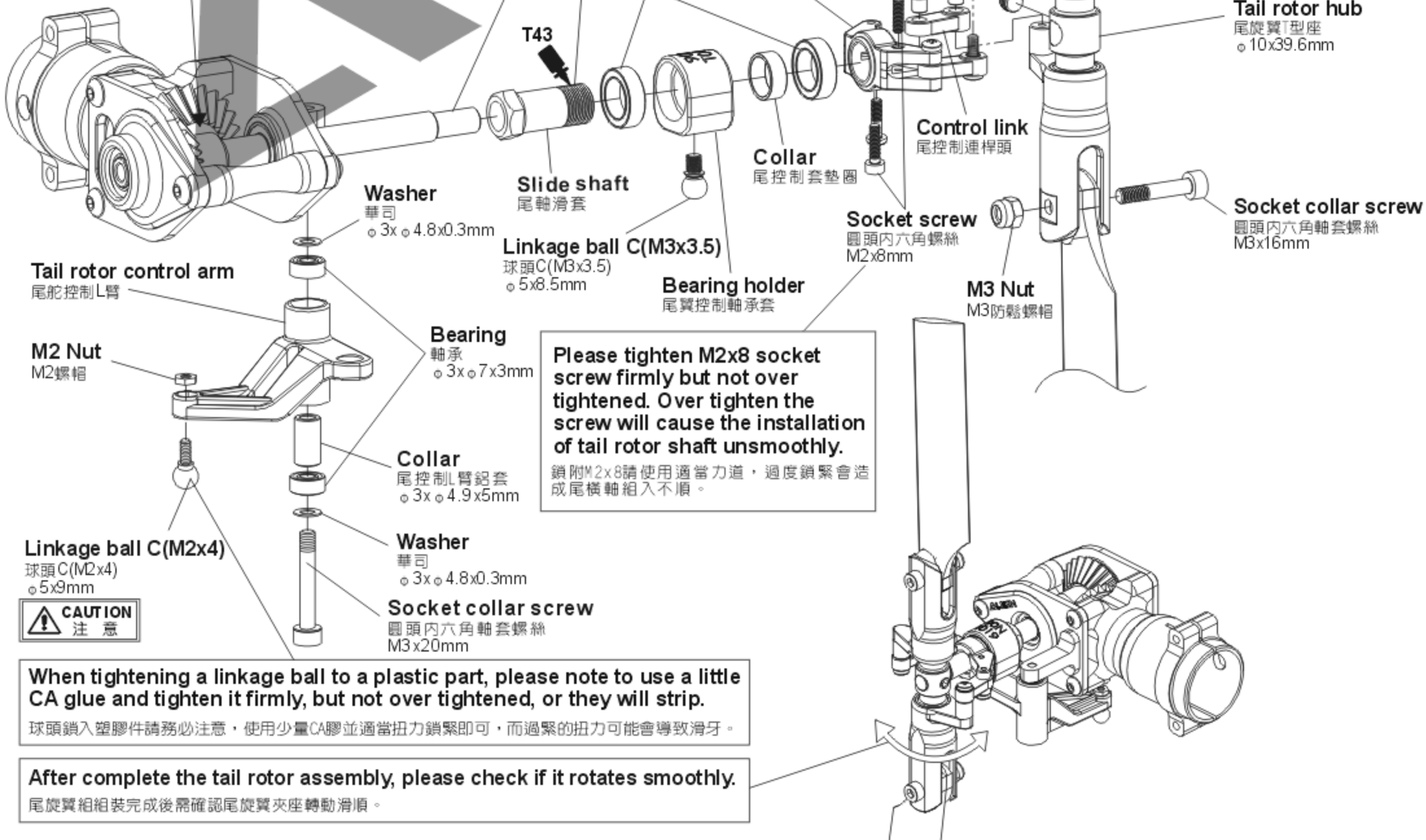

Already assembled by factory, please note to check again.
已組裝完成，請務必自行再確認。

When assembling into the tail boom, please apply some oil on the surface, to make it smooth during the assembling and keep it vertical with the torque tube for smooth rotation.
插入尾管內時，外表抹些潤滑油，以確保平順壓入尾管中並與尾傳動軸保持垂直，讓尾軸傳動順暢。

When assembling the tail boom, please aim at the fixing hole $\phi 5.1$
裝入尾管時請注意孔對準尾管 $\phi 5.1$ 固定孔

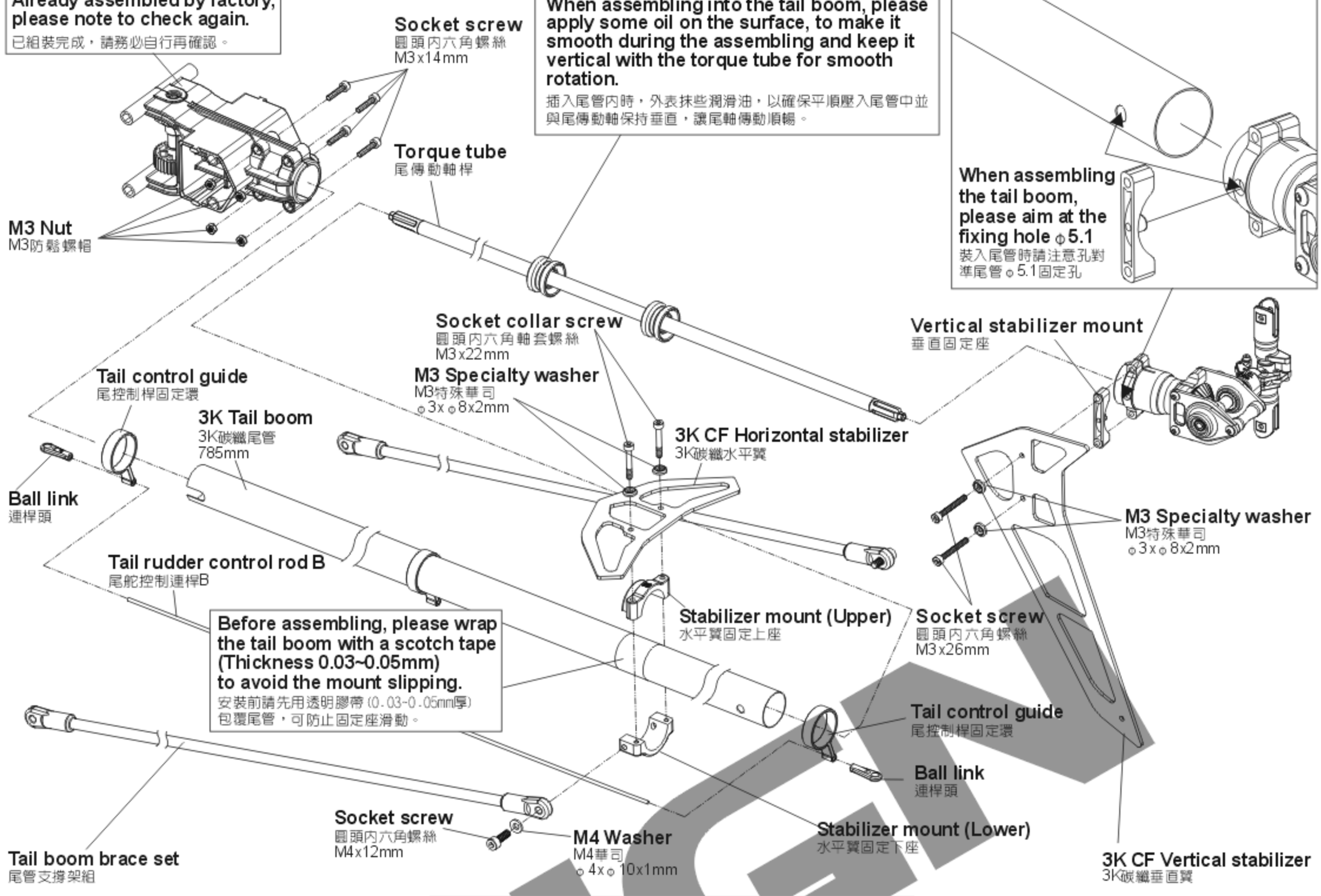

700NT1A

- Socket screw**
圓頭內六角螺絲 (M3x14mm) x 4
- M3 Nut**
M3防鬆螺帽 x 4

700NT2A

- Socket screw**
圓頭內六角螺絲 (M3x26mm) x 2
- M3 Specialty washer**
M3特殊華司 ($\phi 3 \times \phi 8 \times 2\text{mm}$) x 2

700NT2EA

- Socket screw**
圓頭內六角螺絲 (M4x12mm) x 2
- Socket collar screw**
圓頭內六角軸套螺絲 (M3x22mm) x 2
- M3 Specialty washer**
M3特殊華司 ($\phi 3 \times \phi 8 \times 2\text{mm}$) x 2
- M4 Washer**
M4華司 ($\phi 4 \times \phi 10 \times 1\text{mm}$) x 2

700NT3BA

- Ball link**
連桿頭 x 2

Tip to fix the torque tube 傳動軸軸承固定位要領

Please apply some CA glue to fix bearing on the torque tube, avoid CA glue from the dust or may cause the bearing stuck. When assembling into the tail boom, please apply some oil and use the attached torque tube mount helper to press the bearing holder of the torque tube into the tail boom horizontally.
請以少量CA將軸承固定於尾傳動軸上，避免CA沾到軸承的防塵蓋而導致軸承卡死。插入尾管內時，尾傳動軸承墊圈外表抹些潤滑油，利用隨附軸承安裝套管將尾傳動軸承墊圈平行壓入尾管中不可歪斜。

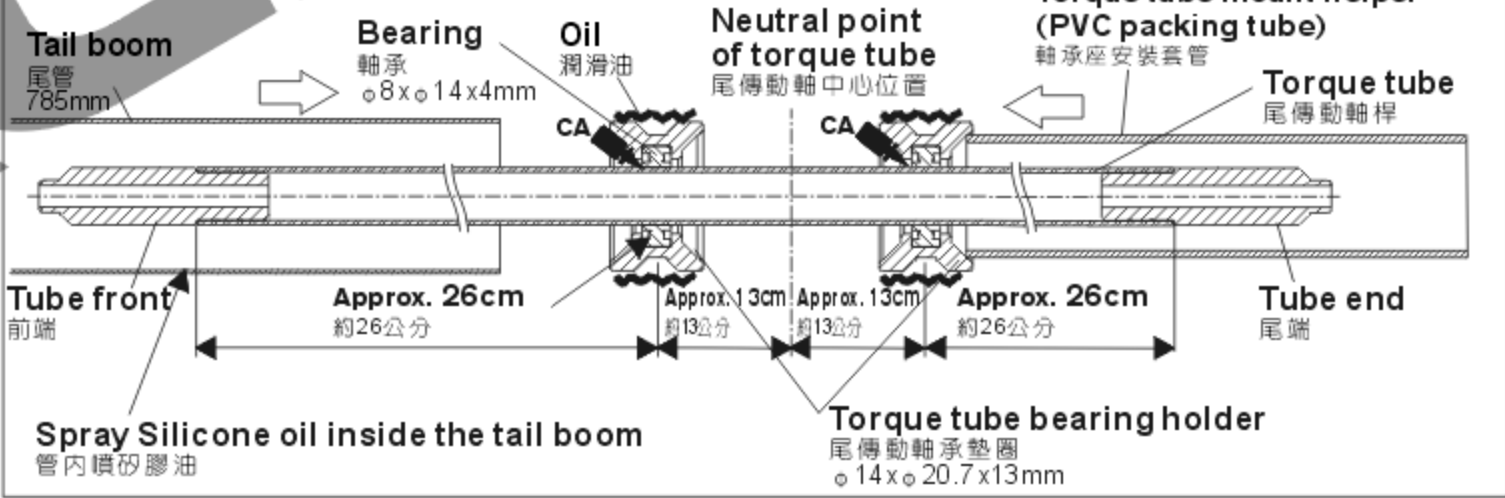

CAUTION
注意

Skewed Torque tube bearing holder will interfere with torque tube rotation and cause unusual vibration.
尾傳動軸承座安裝歪斜會造成傳動軸運轉不順及尾部異常震動等問題

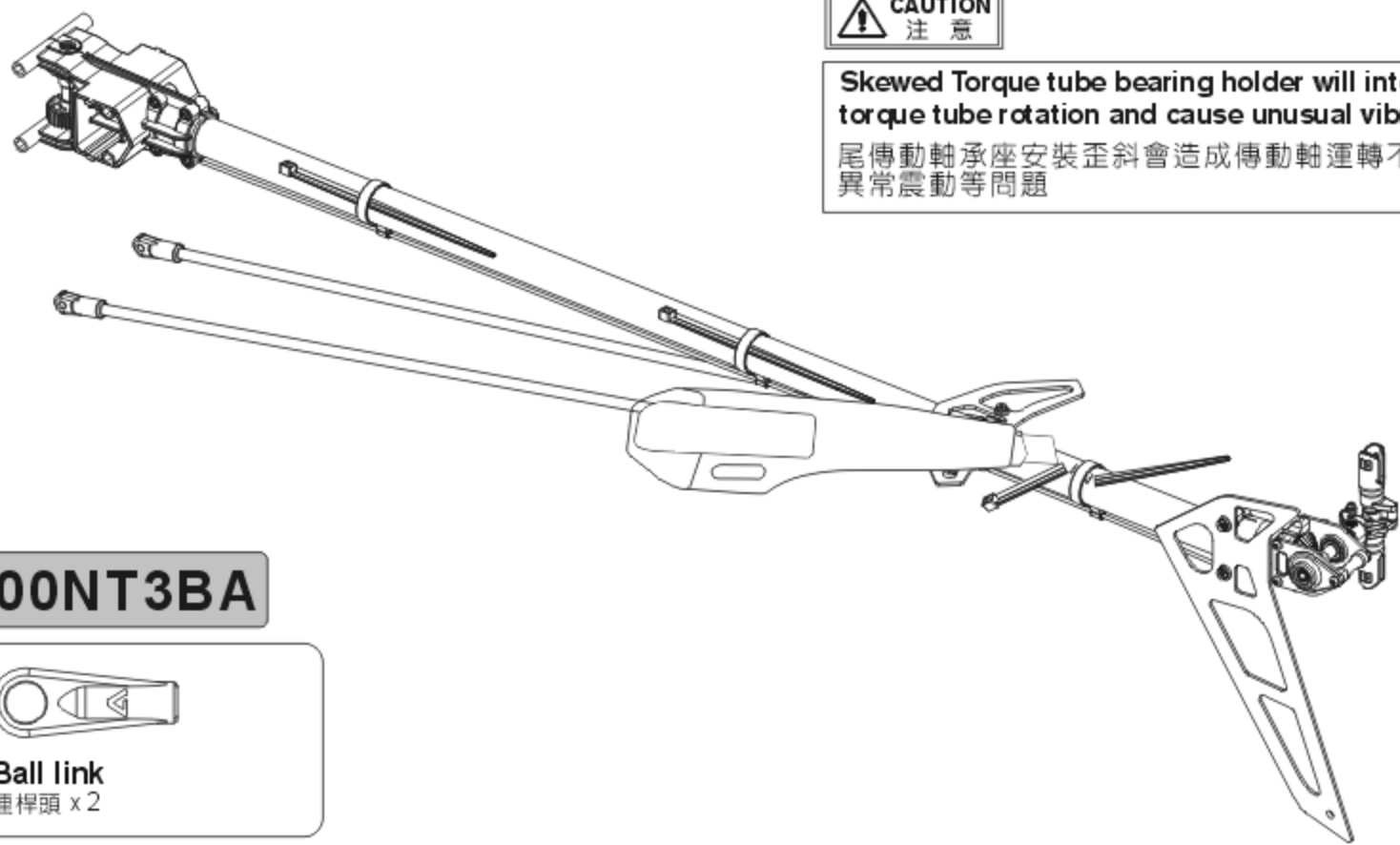

Apply a little amount of T43 thread lock when fixing a metal part.
螺絲鎖附於金屬件請使用適量T43(螺絲膠)

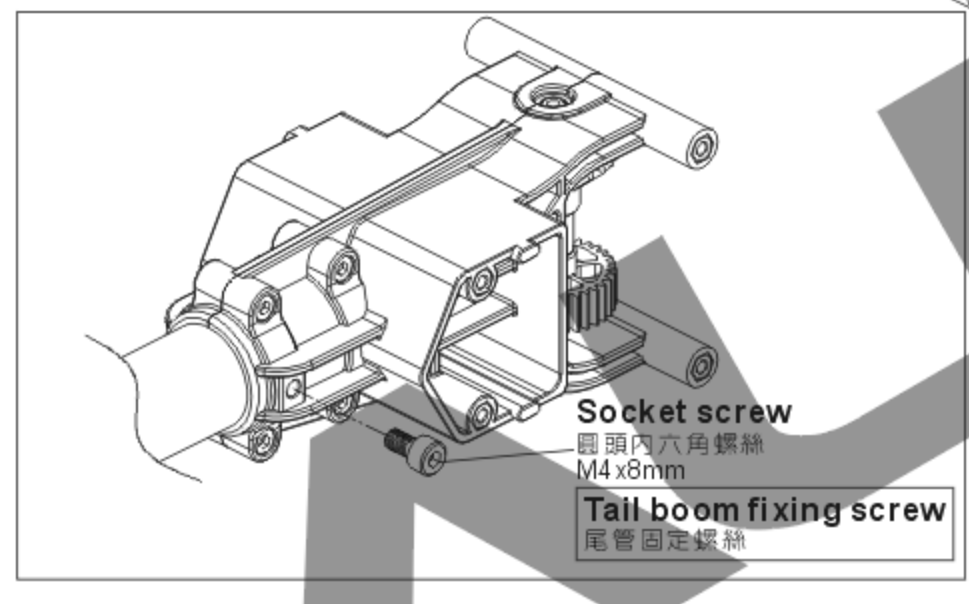
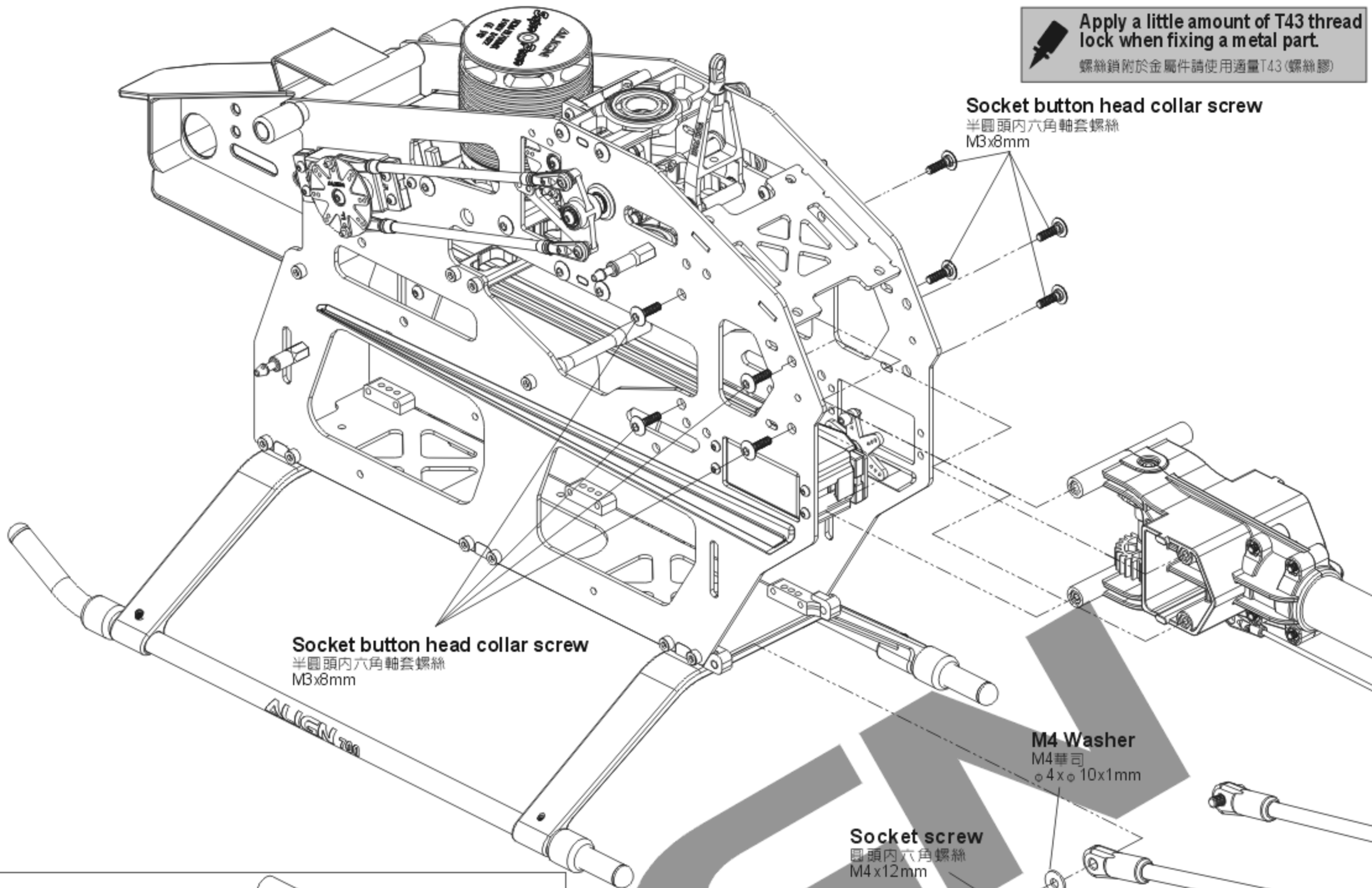

700HB3A

- Socket screw**
圓頭內六角螺絲(M4x12mm) x 2
- M4 Washer**
M4華司(φ4xφ10x1mm) x 2

700NT1A

- Socket button head collar screw**
半圓頭內六角軸套螺絲(M3x8mm) x 8
- Socket screw**
圓頭內六角螺絲(M4x8mm) x 1

700HB5

- Bearing**
軸承(φ15xφ21x4mm) x 2
- One-way bearing**
單向軸承(φ15xφ23x11mm) x 1
- Socket screw**
圓頭內六角螺絲(M2.5x8mm) x 2
- Socket button head screw**
半圓頭內六角螺絲(M3x6mm) x 6

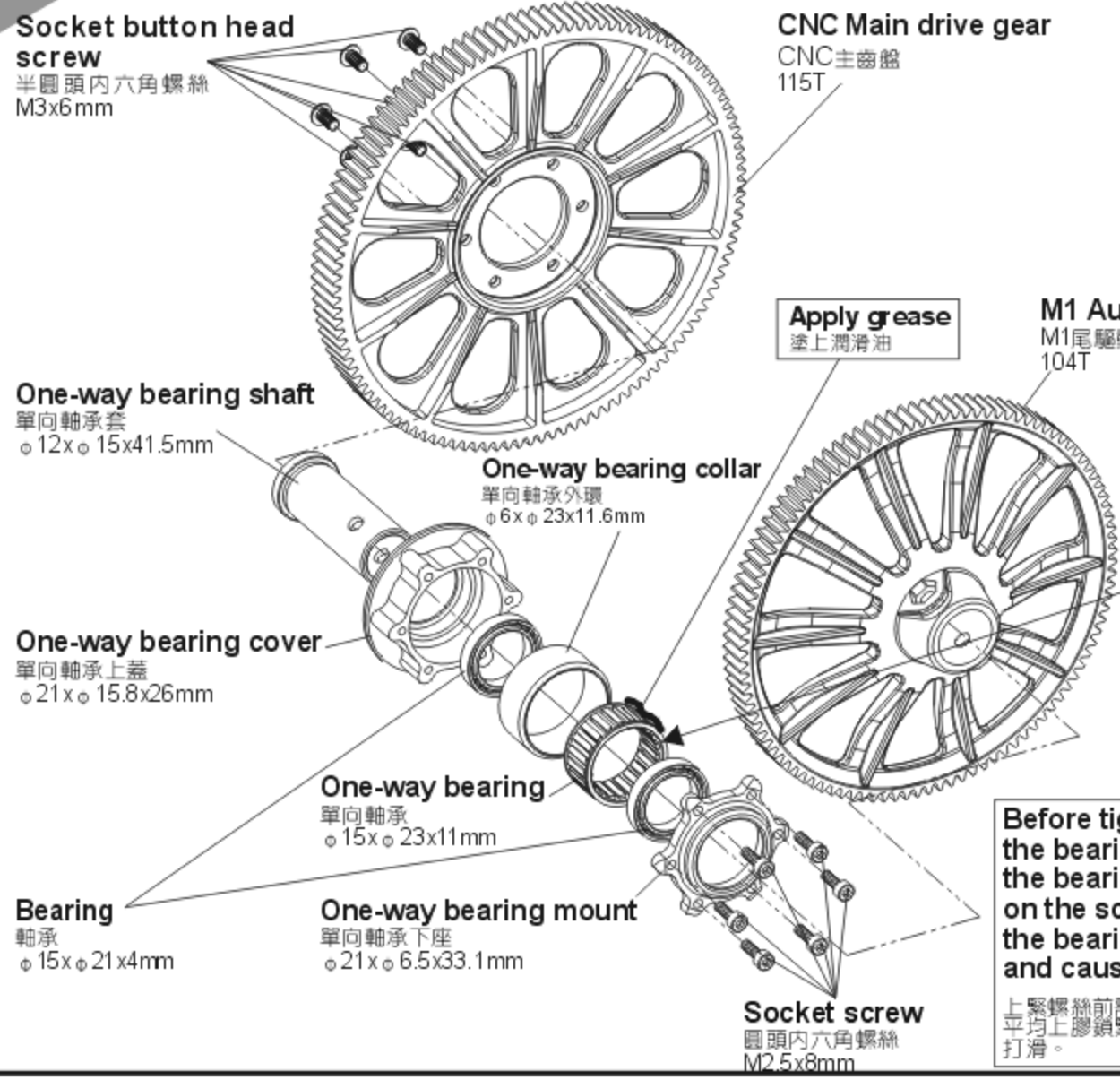

CAUTION
注意

Already assembled by Factory. Before flying, please check if the screws are fixed with glue.
原裝組裝完成品，每一次飛行前請先確認螺絲是否已上膠不會鬆動。

Please note the direction of bearing.
請注意軸承方向

Before tightening the screw, please rotate the bearing and check the concentricity of the bearing. Then apply some glue evenly on the screw and tighten it firmly, to avoid the bearing stuck or heavy load at one side and cause slip.
上緊螺絲前請試轉動確認軸承同心度良好後，才能將螺絲平均上膠鎖緊，以避免造成卡死或單向重負載可能產生的打滑。

Apply a little amount of T43 thread lock when fixing a metal part.
 螺絲鎖附於金屬件請使用適量T43(螺絲膠)

Socket collar screw
 圓頭內六角軸套螺絲
 M5x32mm

When tightening the main blade fixing screw, please tighten it firmly, but not over tighten, or it may cause the damage of main blade holder and result in danger.
 鎖緊主旋翼螺絲須注意適當緊度即可，過緊可能導致主旋翼夾座受損，飛行意外發生。

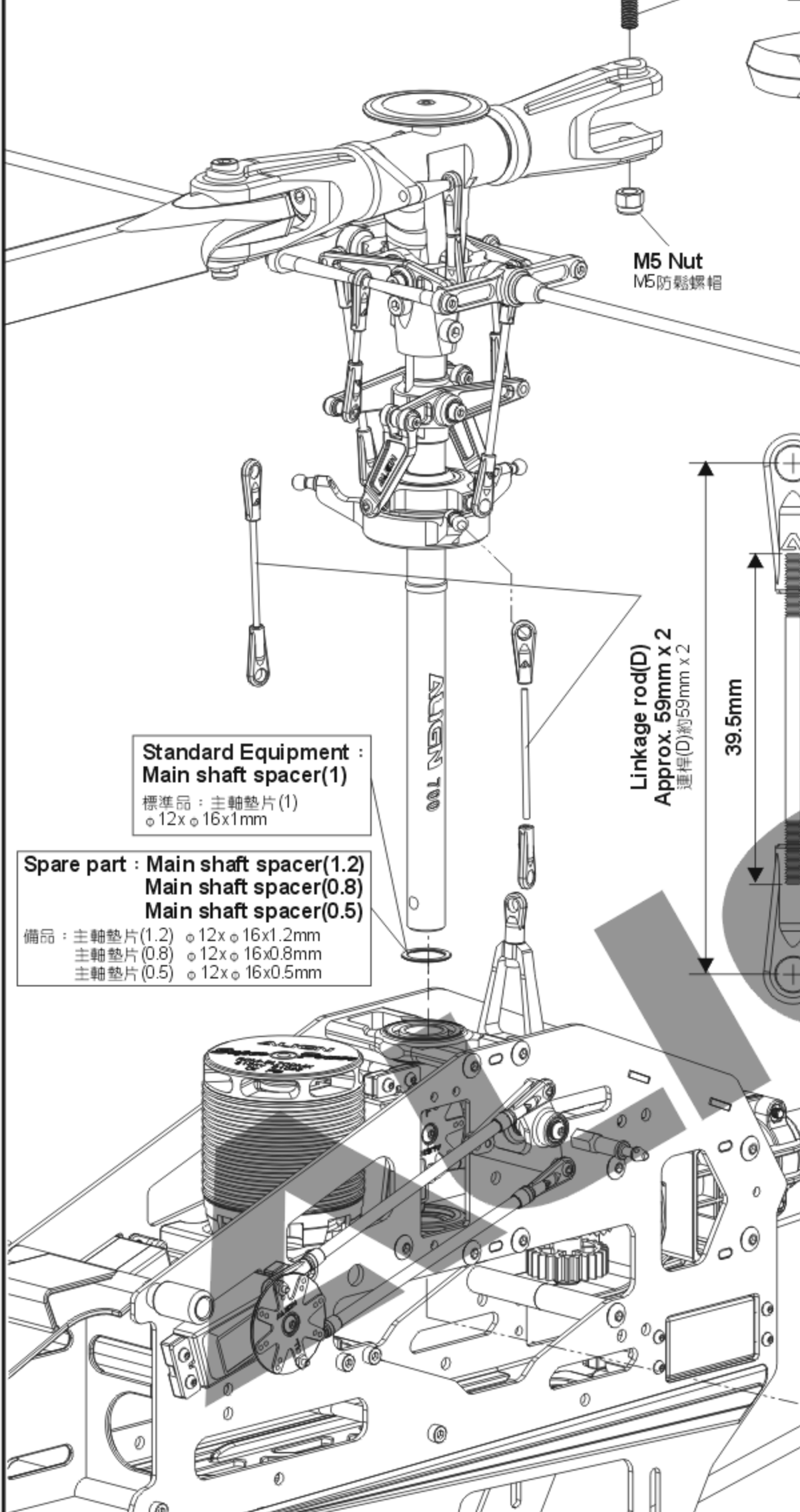

Standard Equipment :
 Main shaft spacer(1)
 標準品：主軸墊片(1)
 φ12xφ16x1mm

Spare part : Main shaft spacer(1.2)
 Main shaft spacer(0.8)
 Main shaft spacer(0.5)
 備品：主軸墊片(1.2) φ12xφ16x1.2mm
 主軸墊片(0.8) φ12xφ16x0.8mm
 主軸墊片(0.5) φ12xφ16x0.5mm

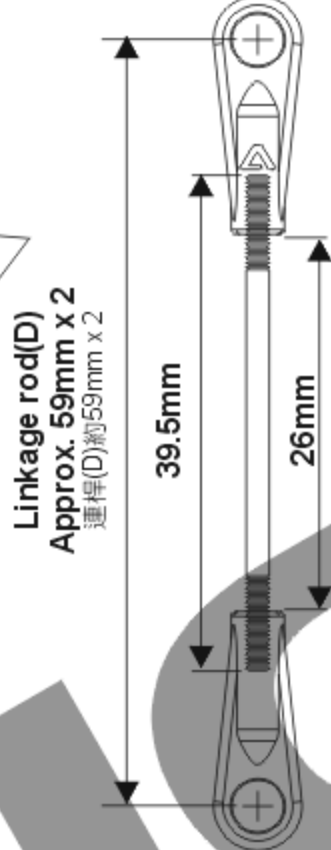

700NH1A

- Main Blade Fixing Screw**
 鎖主旋翼用螺絲
- Socket collar screw
 圓頭內六角軸套螺絲(M5x32mm) x 2
- M5 Nut
 M5防鬆螺帽 x 2

700HB5

- Socket collar screw
 圓頭內六角軸套螺絲(M4x27mm) x 1
- M4 Nut
 M4防鬆螺帽 x 1

700NH4A

- Main shaft spacer(1)
 主軸墊片(1)(φ12xφ16x1mm) x 1
- Spare part:
 Main shaft spacer(0.8)
 備品：主軸墊片(0.8)
 (φ12xφ16x0.8mm) x 1
- Spare part:
 Main shaft spacer(1.2)
 備品：主軸墊片(1.2)
 (φ12xφ16x1.2mm) x 1
- Spare part:
 Main shaft spacer(0.5)
 備品：主軸墊片(0.5)
 (φ12xφ16x0.5mm) x 1

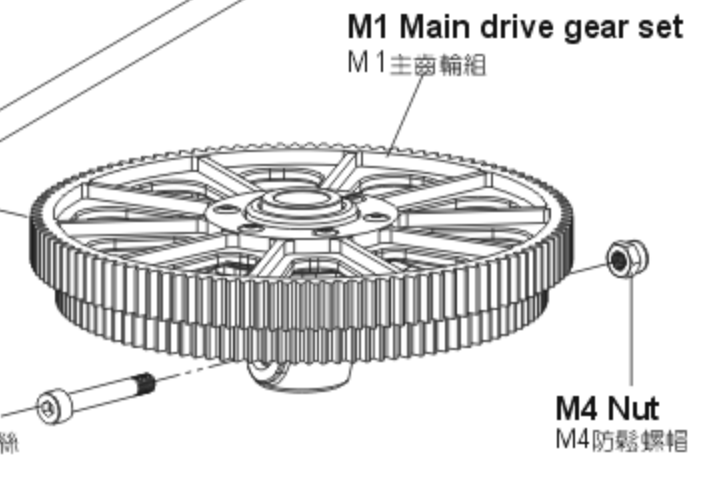

700HZ2A

- Ball link
 連桿頭 x 4

700HZ2

- Linkage rod(D)
 連桿(D)(φ1.96x39.5mm) x 2

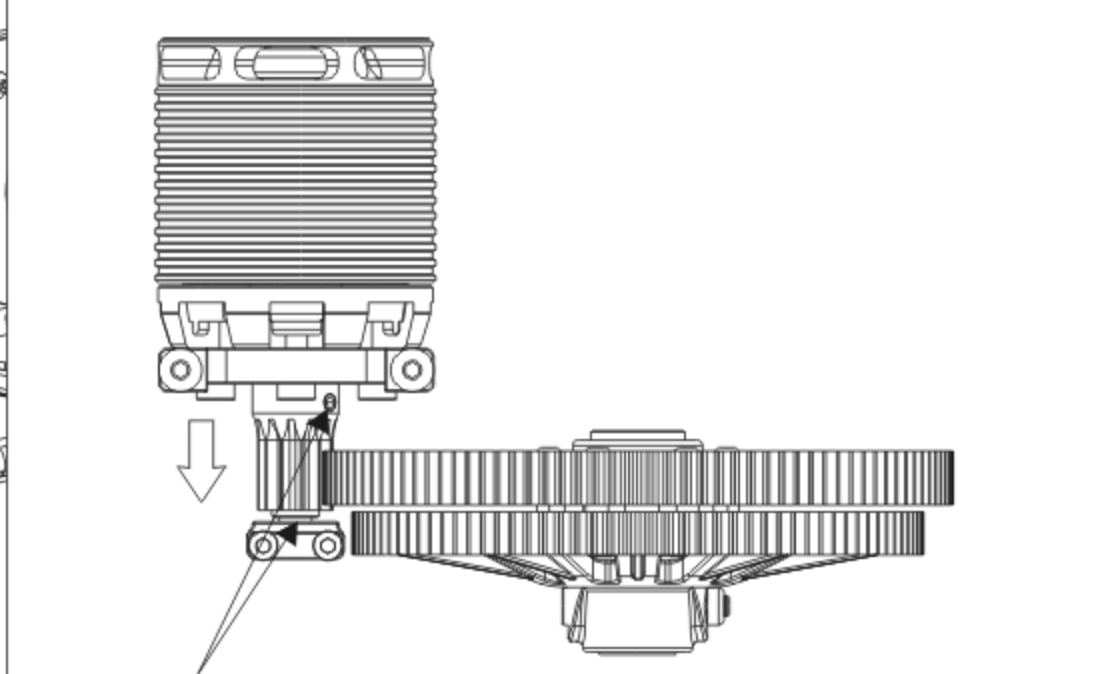

Before fastening the M4 set screw, make sure the motor pinion gear is contacted with the bearing in the motor gear case downward.
 馬達主齒向下頂到馬達齒座軸承後，再將M4止洩螺絲鎖緊。

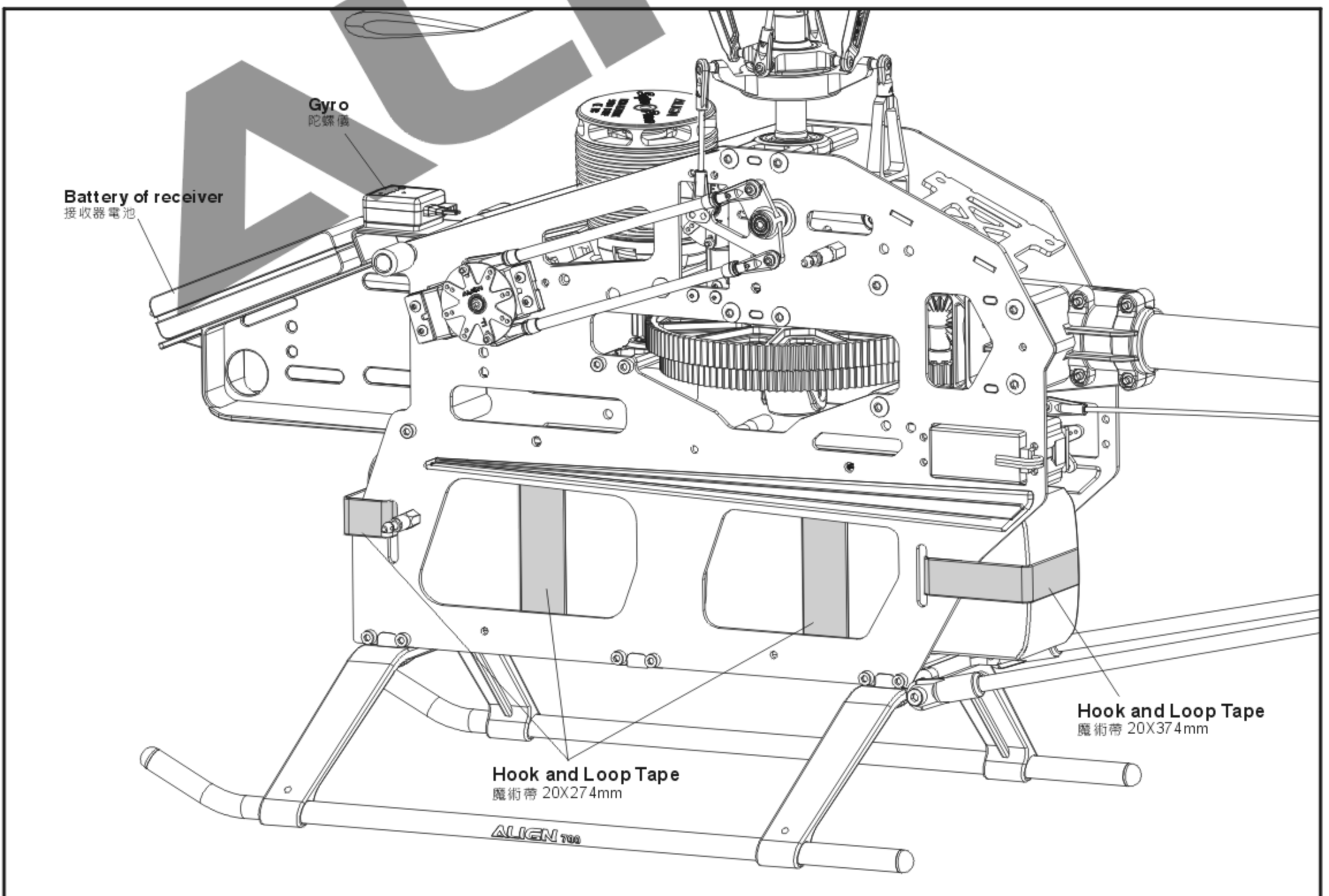
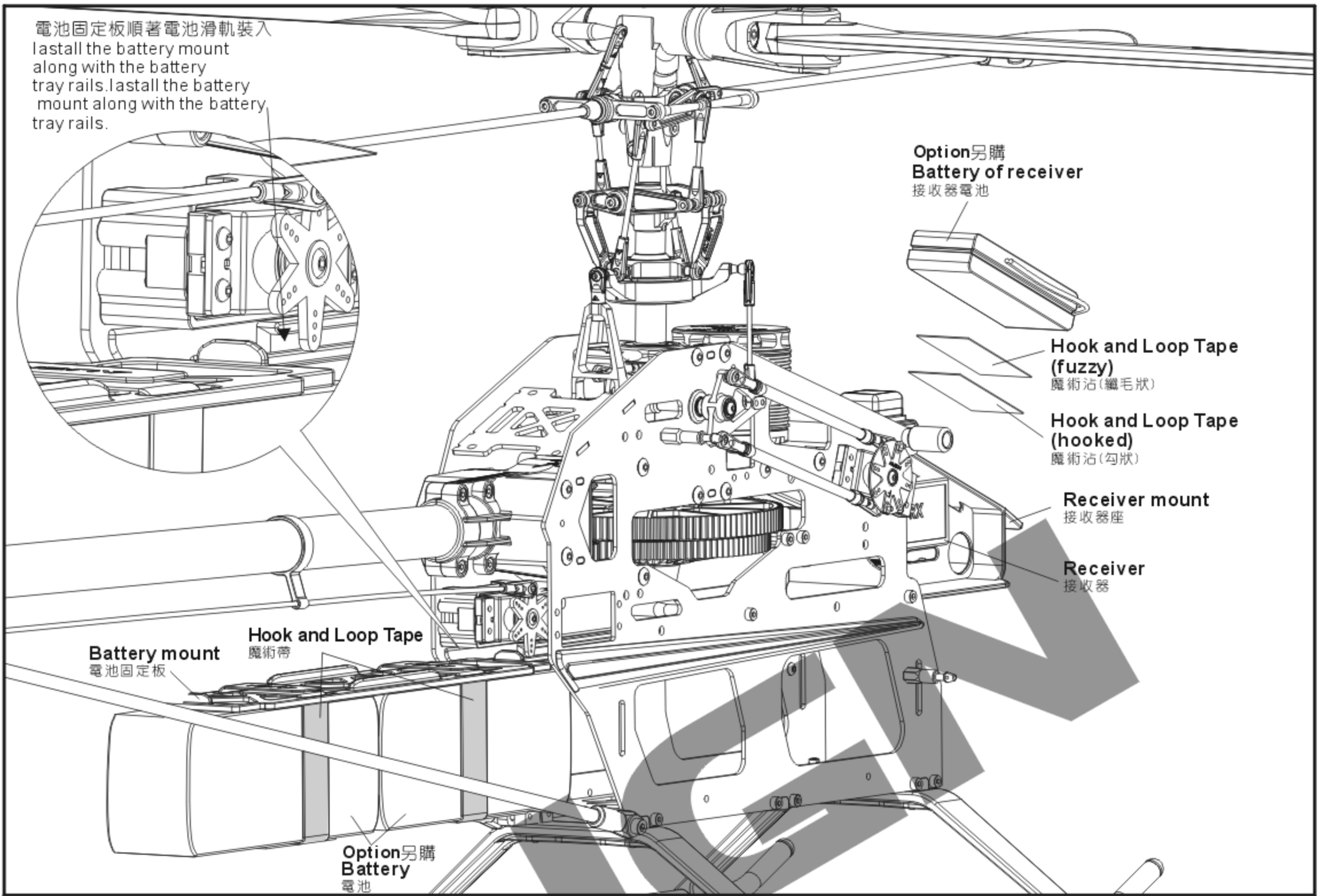

Battery installation illustration(1) 電池安裝示意圖(1)

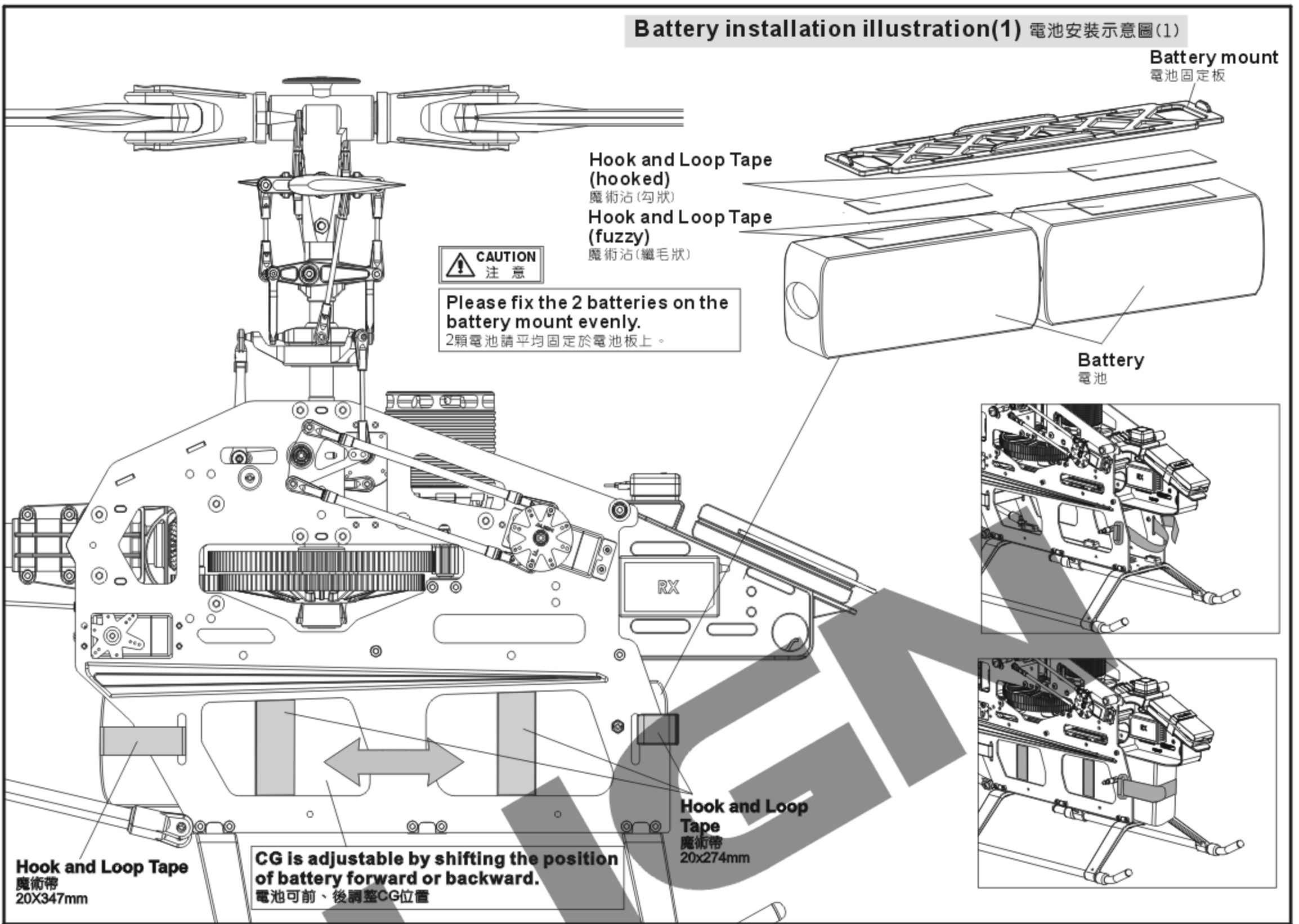

Battery installation illustration(2) 電池安裝示意圖(2)

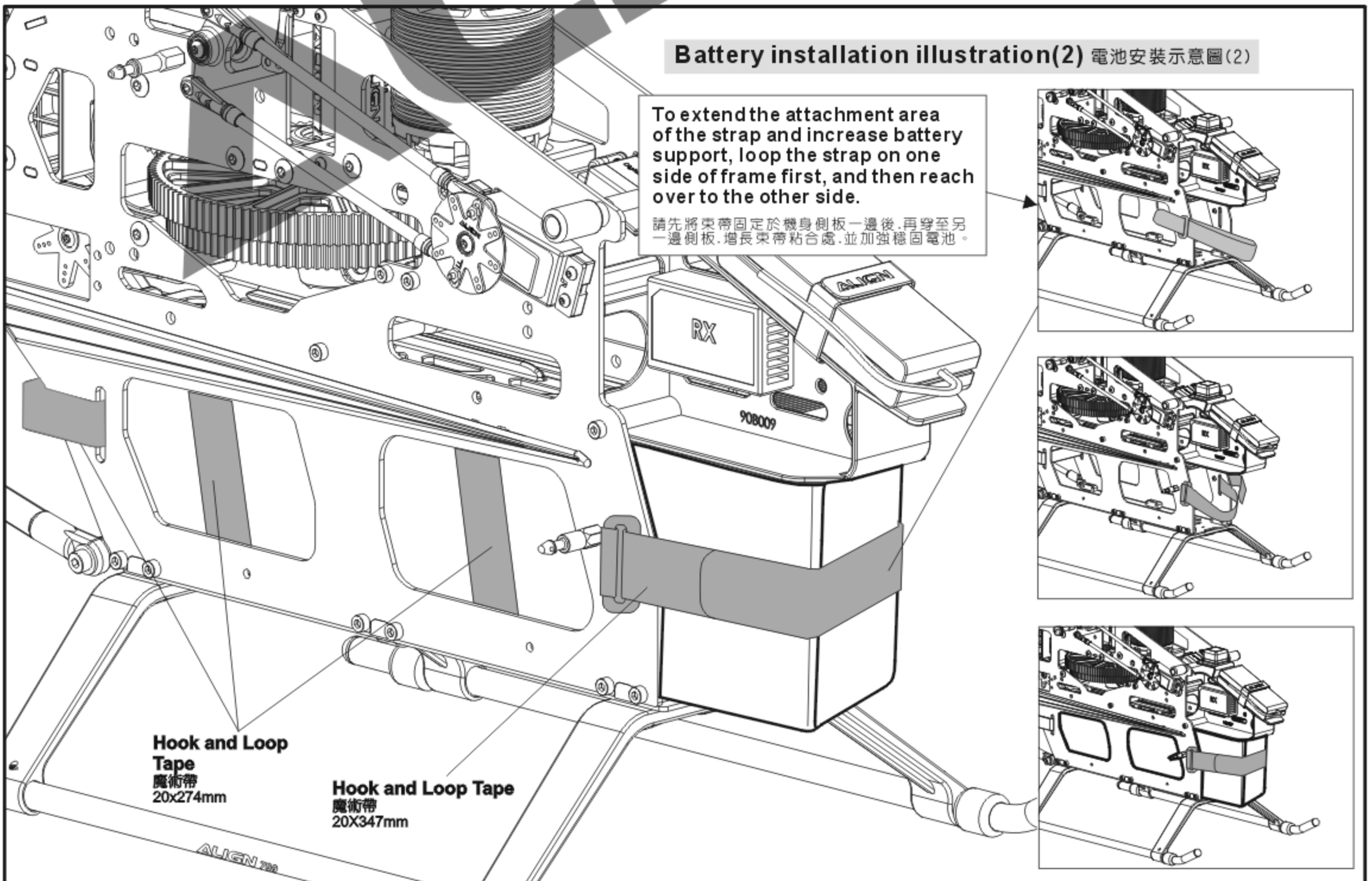

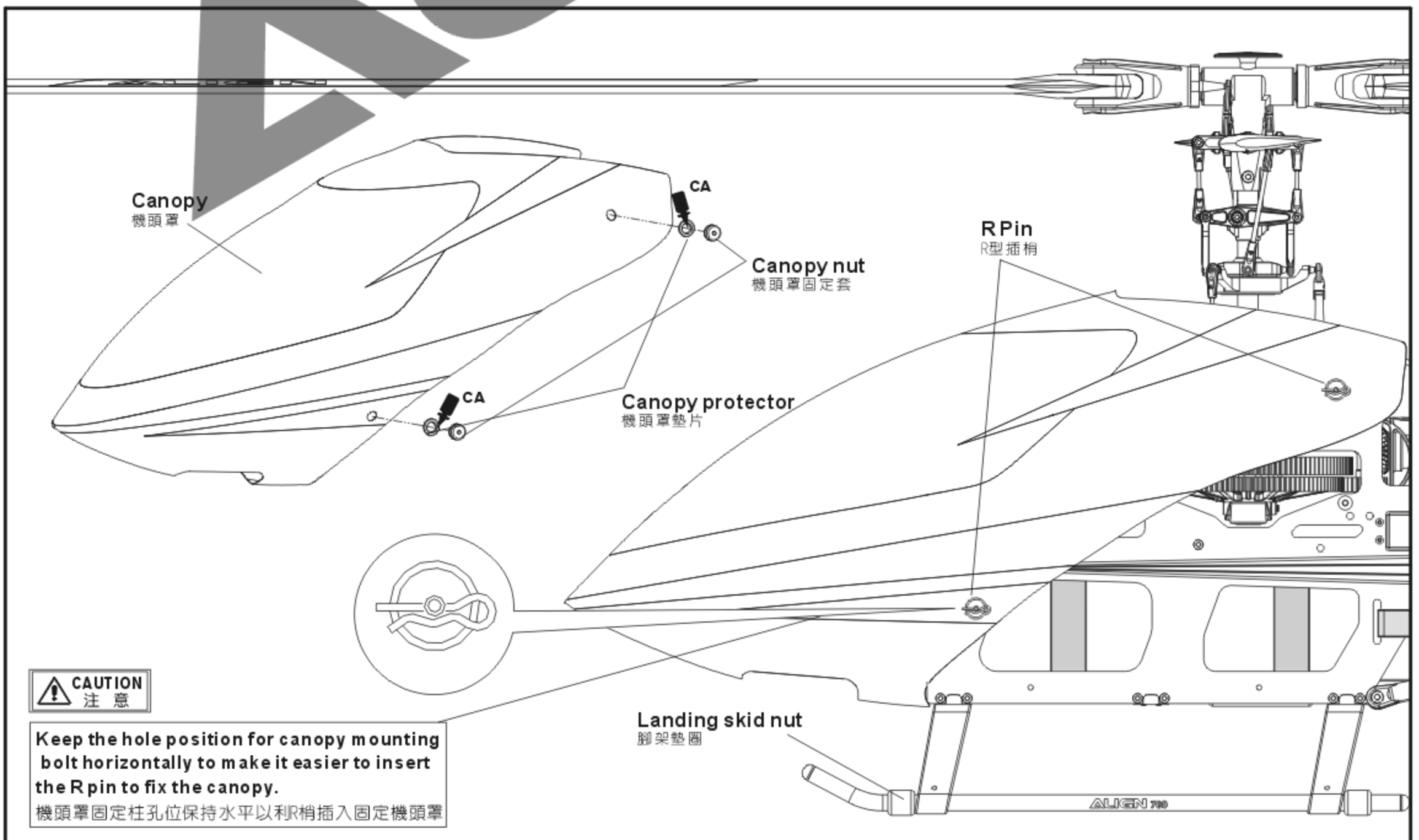
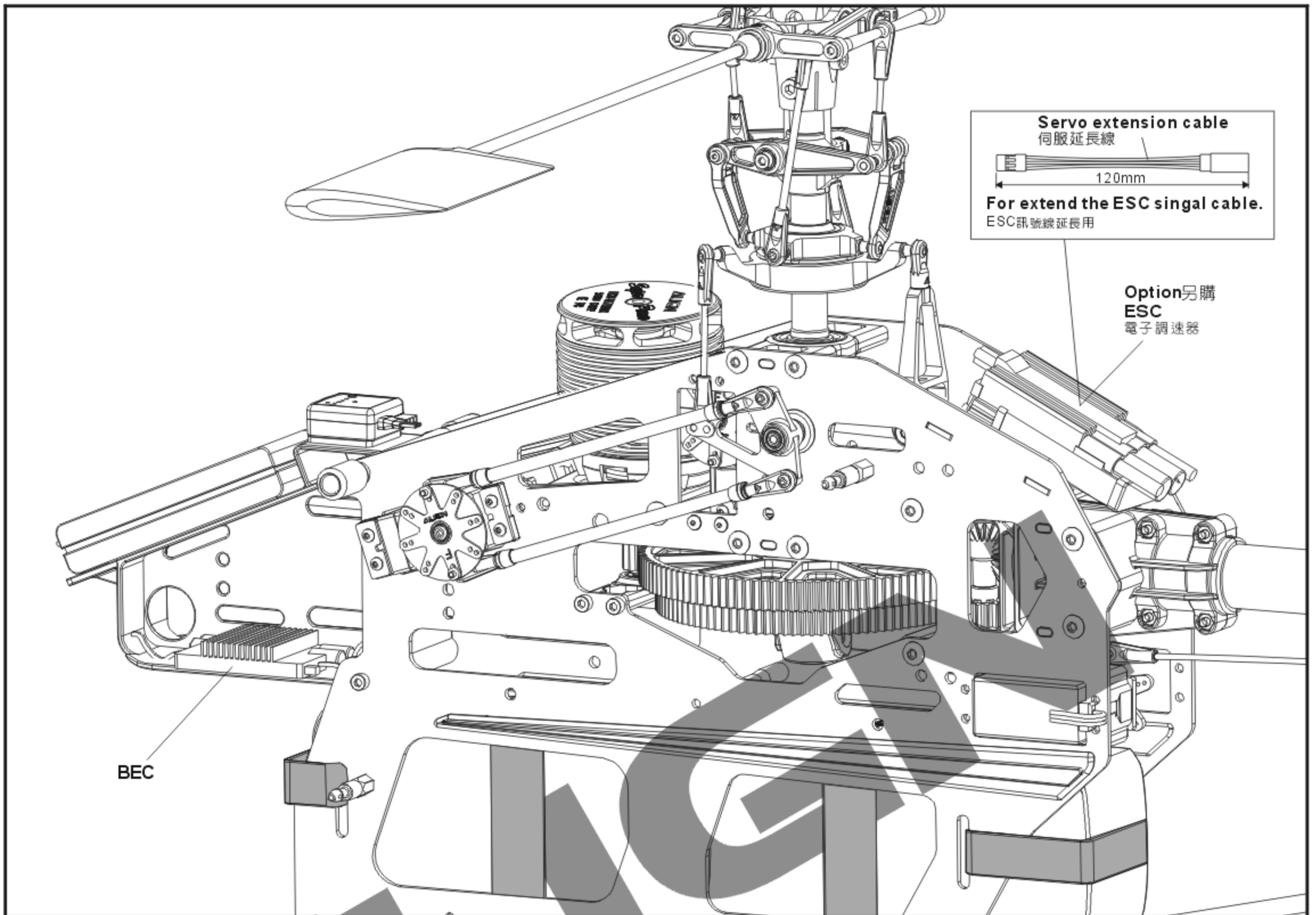

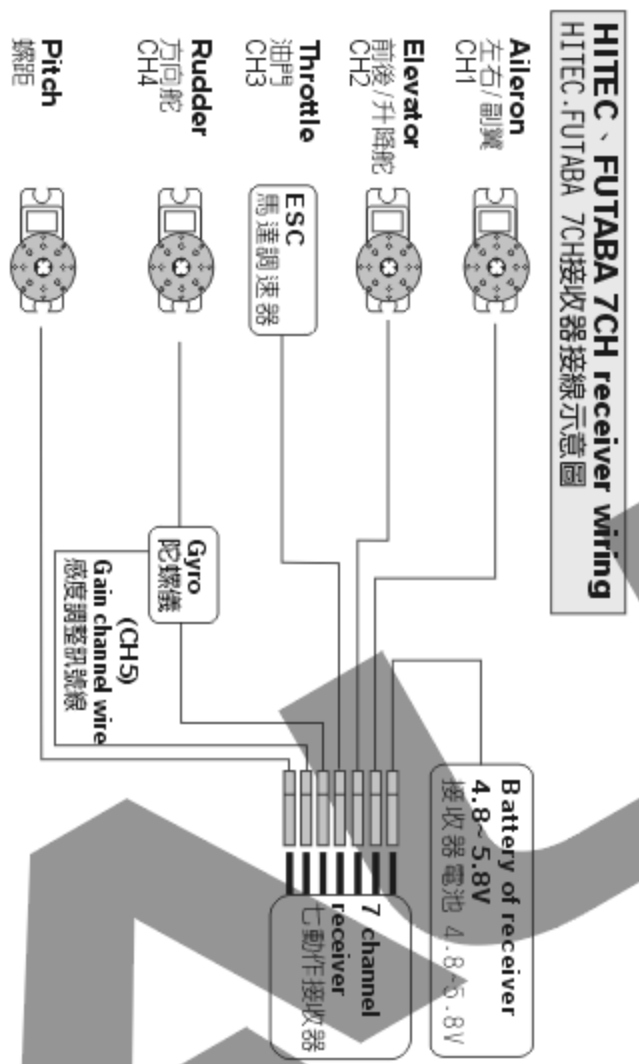
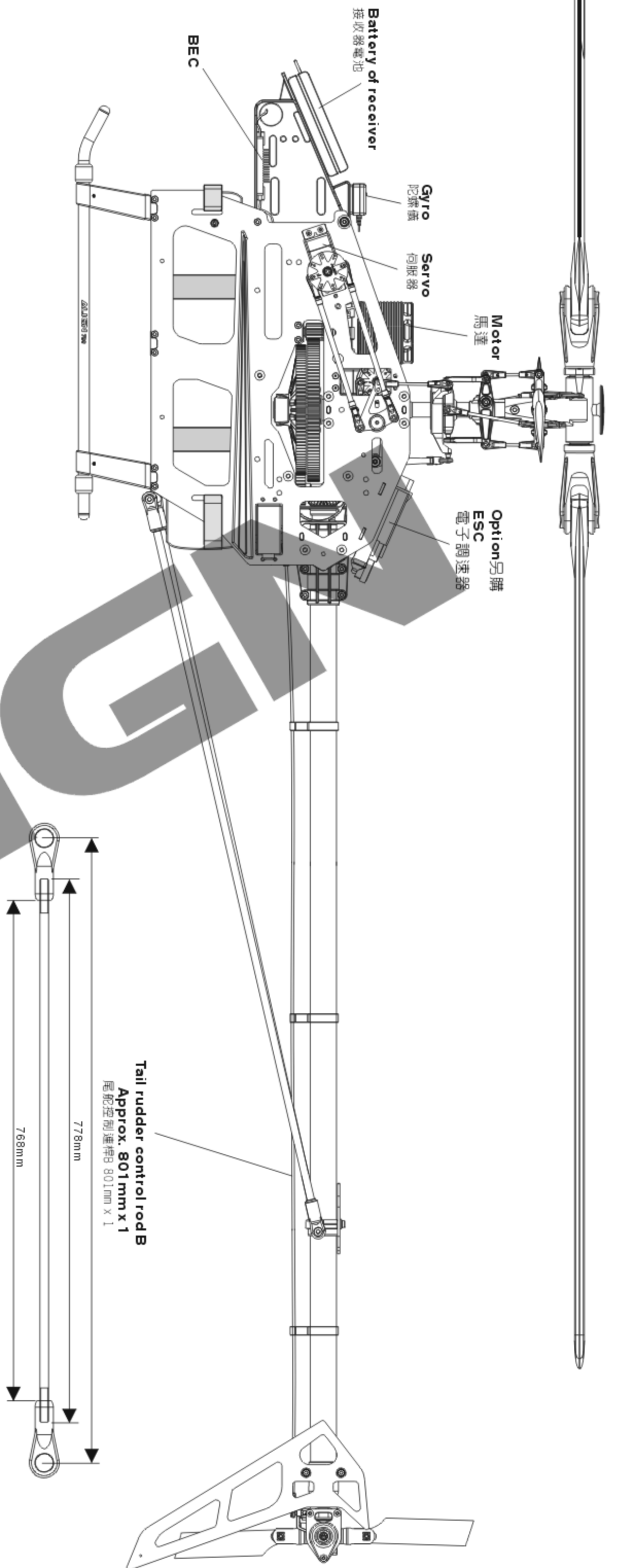

7-Channel Receiver is adequate for the requirements of the T-REX heli.

You will need the following channels at a minimum: Throttle, Rudder, Elevator, Aileron, and especially Pitch(CH6) and Gyro(CH5) controls. 七動作的接收器已足夠應對T-REX遙控直升機的頻道需求，除了油門、方向舵、升降舵、副翼等基本動作外，亦可以對應具備感度調整訊號線的陀螺儀(CH5)與螺距(CH6)。

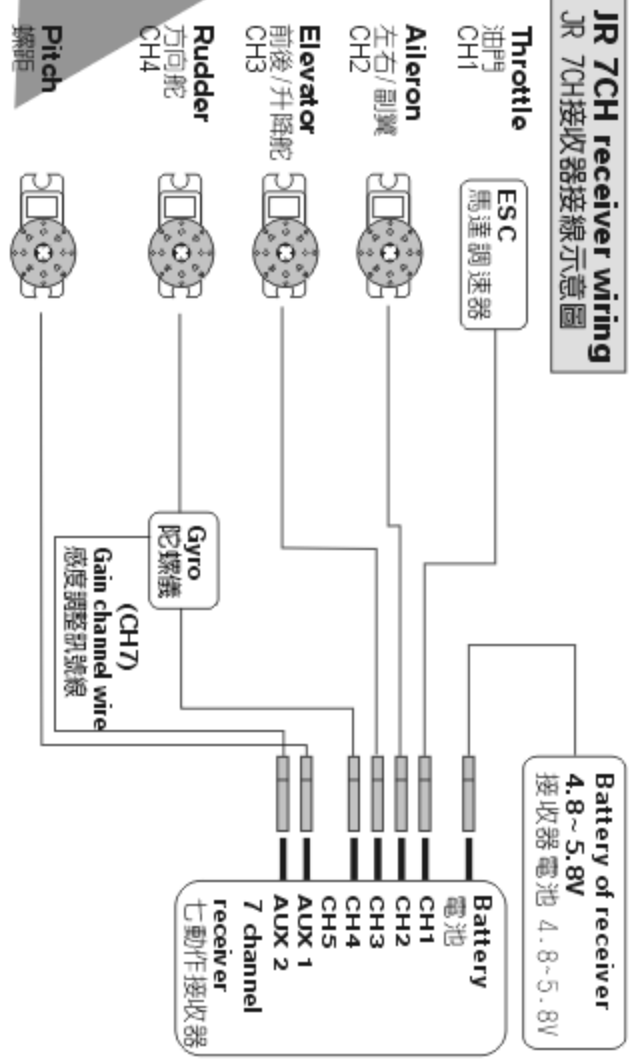

7-Channel Receiver is adequate for the requirements of the T-REX heli.

You will need the following channels at a minimum: Throttle, Rudder, Elevator, Aileron, and especially Pitch(AUX 1) and Gyro(AUX 2) controls. 七動作的接收器已足夠應對T-REX遙控直升機的頻道需求，除了油門、方向舵、升降舵、副翼等基本動作外，亦可以對應具備感度調整訊號線的陀螺儀(AUX 2)與螺距(AUX 1)。

To set this option is to turn on the transmitter and connect to BEC power.
此項設定只要開啓發射器，接上BEC電源即可進行操作。

JR Transmitter/Servo JR遙控器對應伺服器關係

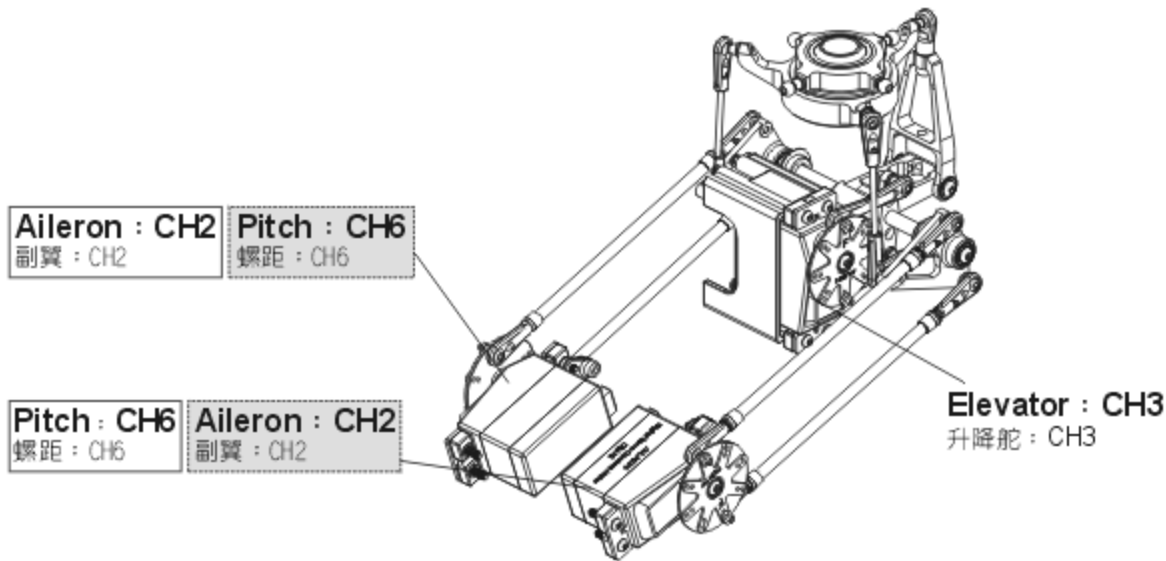

Positions of CH2 · CH6 are exchangeable, After assembling as photo (Note: Set the transmitter under CCPM 120 degrees mode), pull throttle stick (pitch) upward. If one swashplate servo (or two servos) moves downward, adjust reverse switch (REV) on the transmitter to make it moves upward. If three servo move downward, adjust the travel value (+) of SWASH CH6 on the transmitter to make them move upward. When the actions of Aileron and Elevator are opposite, adjust travel values of SWASH CH2 and Ch3.

CH2 · CH6可互換配置，依圖連結後(注意：遙控器須設定於CCPM 120°十字盤模式)，將油門搖桿(Pitch)往上推，若十字盤伺服器有1個或2個往下移時，請調整遙控器的反轉開關(REV)使伺服器往上，若3個伺服器同時往下移時，請調整遙控器 SWASH CH6 行程量的正負值，使伺服器同時往上平移，副翼與前後動作相反時，同樣調整 SWASH CH2 · CH3 行程量正負值。

FUTABA/HITEC Transmitter/Servo FUTABA/HITEC遙控器對應伺服器關係

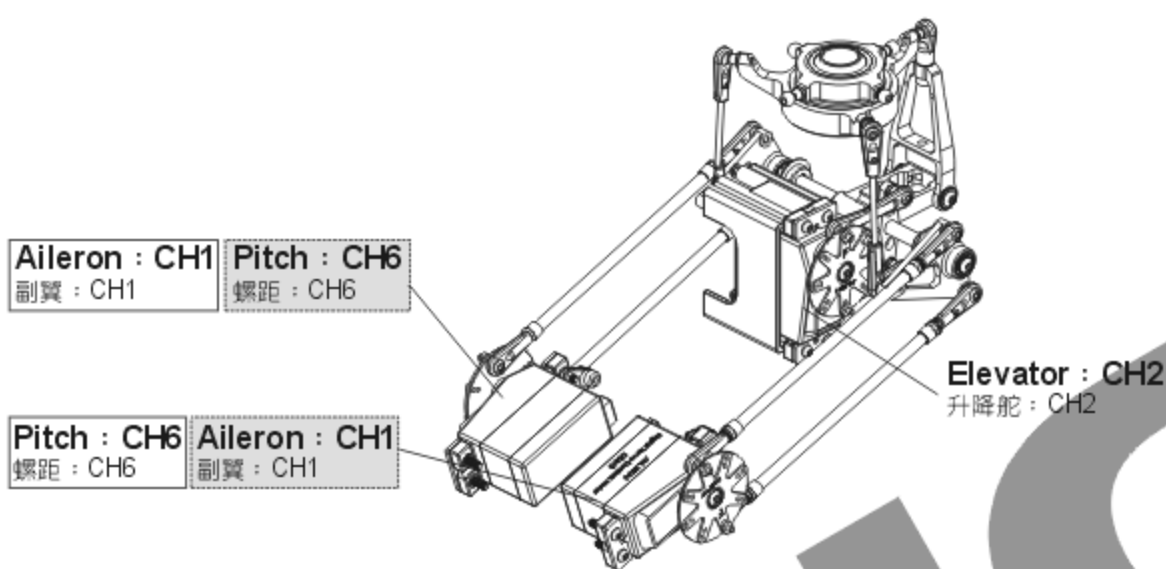

Positions of CH1 · CH6 are exchangeable, After assembling as photo (Note: Set the transmitter under CCPM 120 degrees mode), pull throttle stick (pitch) upward. If one swashplate servo (or two servos) moves downward, adjust reverse switch (REV) on the transmitter to make it moves upward. If three servo move downward, adjust the travel value (+) of SWASH CH6 on the transmitter to make them move upward. When the actions of Aileron and Elevator are opposite, adjust travel values of SWASH CH1 and Ch2.

CH1 · CH6可互換配置，依圖連結後(注意：遙控器須設定於CCPM 120°十字盤模式)，將油門搖桿(Pitch)往上推，若十字盤伺服器有1個或2個往下移時，請調整遙控器的反轉開關(REV)使伺服器往上，若3個伺服器同時往下移時，請調整遙控器 SWASH CH6 行程量的正負值，使伺服器同時往上平移，副翼與前後動作相反時，同樣調整 SWASH CH1 · CH2 行程量正負值。

13.ADJUSTMENTS FOR GYRO AND TAIL NEUTRAL SETTING 陀螺儀與尾翼中立點設定調整

Recommend to choose Head Lock type for Gyro and turn off Revolution mixing(RVMX) mode on the transmitter, then set the gain switch on the transmitter and the gyro to Head lock mode. The gain setting is about 70%, and after transmitter setting, connect to BEC power to work on tail neutral setting.

Note : When turn on BEC power, please do not touch tail rudder stick and the helicopter. Then wait for 3 seconds, make tail servo arm and tail servo at a right angle(90 degrees), tail pitch assembly must be correctly fixed about in the middle of the travel of tail rotor shaft for standard neutral setting.

陀螺儀選擇，建議選用鎖定式陀螺儀，其發射器內陀螺儀設定請關閉根軸混控模式，並將發射器上的感度開關與陀螺儀切至鎖定模式，感度設約 70% 左右，發射器設定完成後接上BEC接收電源，即可進行尾中立點設置。

注意：當啓動BEC電源時請勿撥動尾舵搖桿或碰觸機體，待3秒陀螺儀鎖定後尾伺服器需與尾伺服器約成 90°，尾旋翼控制組須正確置於尾橫軸行程約中間位置，即為標準尾中立點設定。

TAIL NEUTRAL SETTING 尾中立點設定

After setting Head Lock mode, correct setting position of tail servo and tail pitch assembly is as photo. If the tail pitch assembly is not at the neutral position, please adjust the length of rudder control rod to trim.

陀螺儀鎖定後尾伺服器與尾 Pitch控制組正確擺置位置。若尾 Pitch控制組未置中時請調整尾控制連桿的長度來修正。

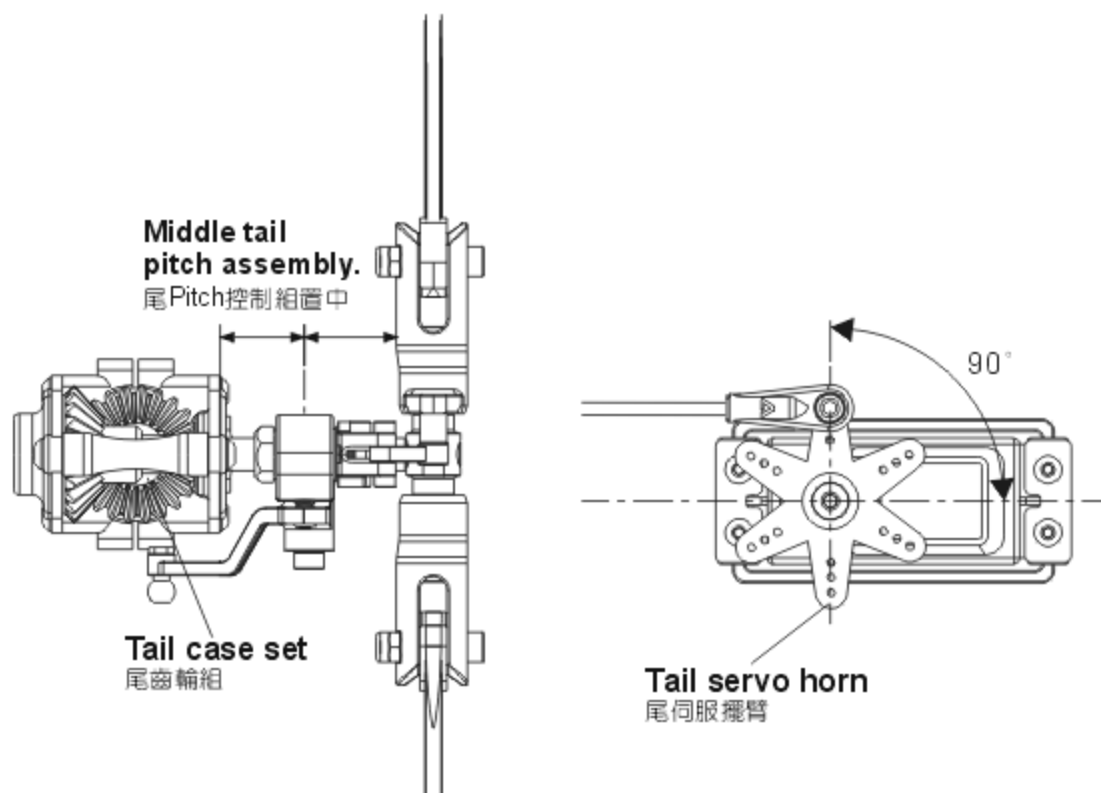

HEAD LOCK DIRECTION SETTING OF GYRO 陀螺儀鎖定方向設定

To check the head lock direction of gyro is to move the tail counterclockwise and the tail servo horn will be trimmed counterclockwise. If it trims in the reverse direction, please switch the gyro to "REVERSE".

陀螺儀鎖定方向確認，當手搖尾部反時鐘擺動，尾伺服器擺臂應反時鐘修正，反向時請切換陀螺儀上"鎖定反向"開關修正。

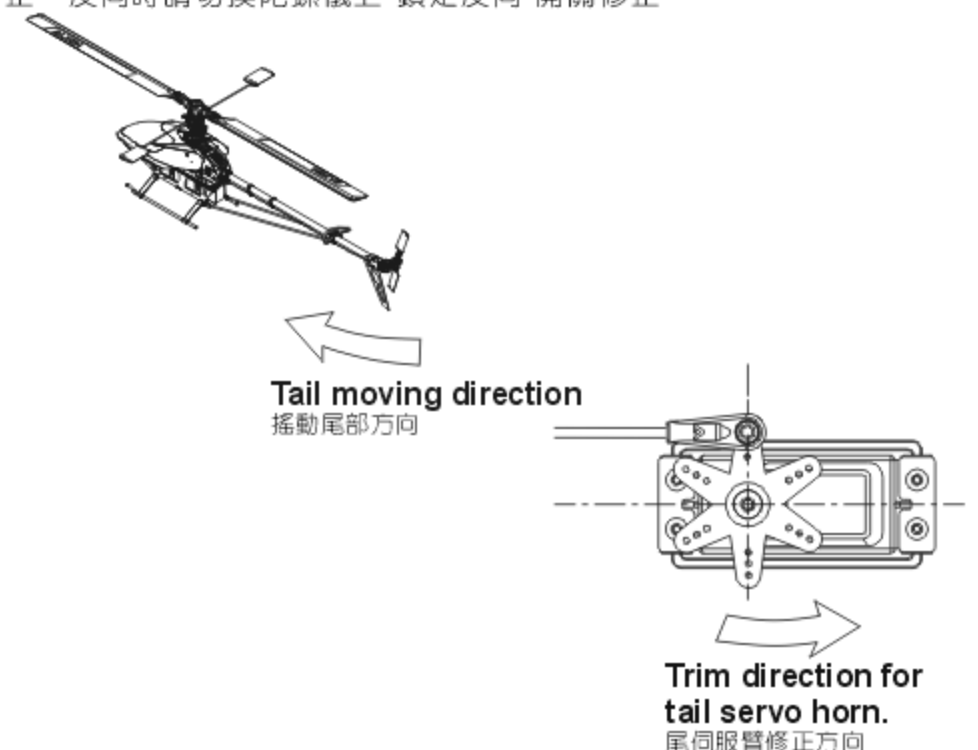

GENERAL FLIGHT 一般飛行模式

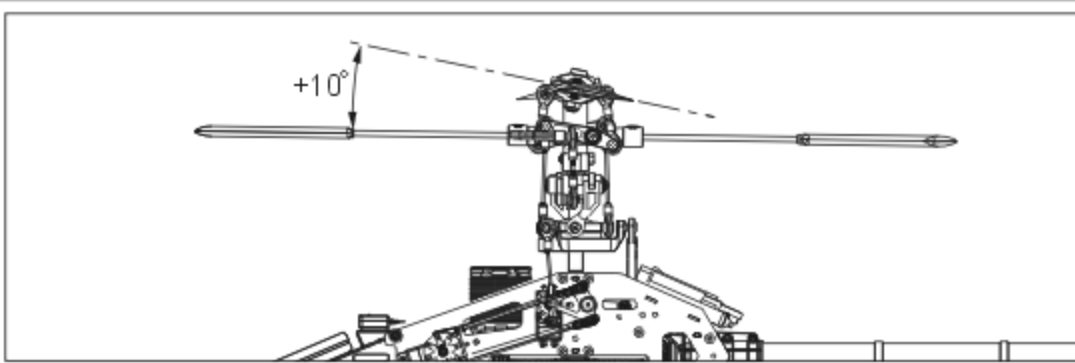

Stick position at high/Throttle 100%/Pitch +10°
搖桿高速/油門100%/Pitch+10°

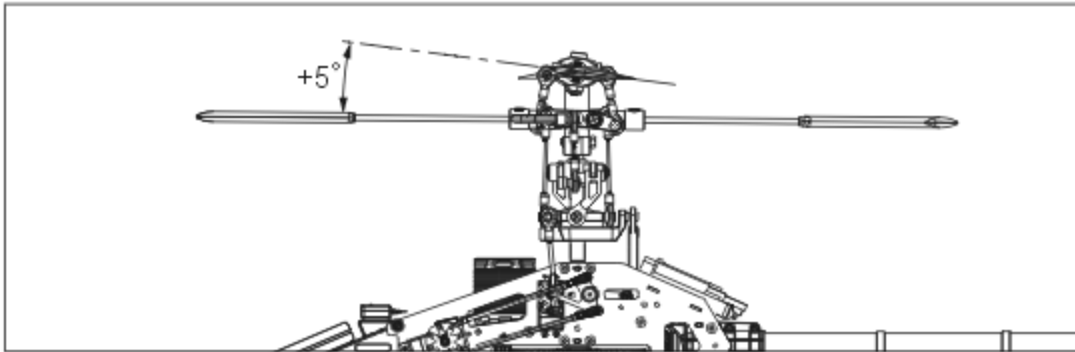

Stick position at Hovering/Throttle 70%/Pitch +5°
搖桿停懸/油門70%/Pitch+5°

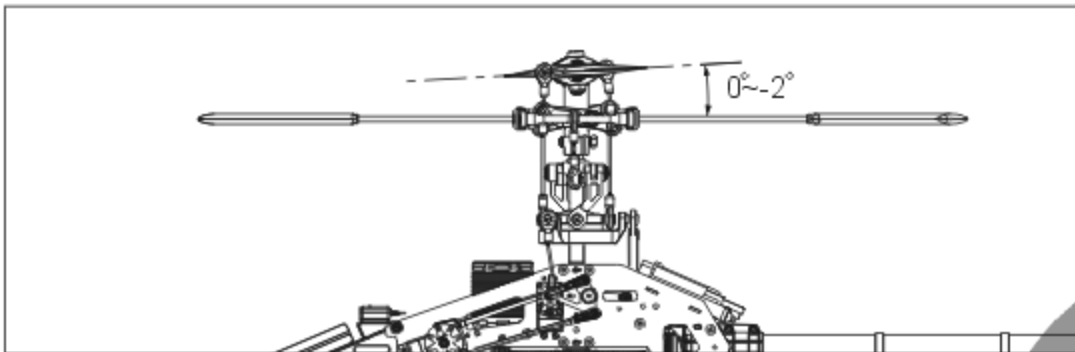

Stick position at low/Throttle 0%/Pitch 0~-2°
搖桿低速/油門0%/Pitch 0~-2°

GENERAL FLIGHT
一般飛行模式

	Throttle 油門	Pitch 螺距
5	100% High speed 100% 高速	+10°
4	85%	
3	70% Hovering 70% 停懸	+5°
2	45%	
1	0% Low speed 0% 低速	0~-2°

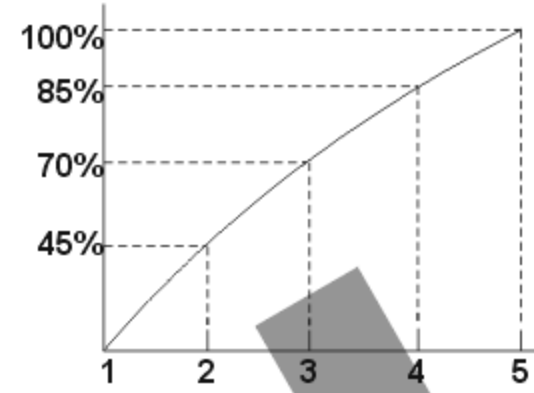

Throttle Curve (Hovering Flight)
停懸模式油門曲線

3D FLIGHT 3D特技飛行模式

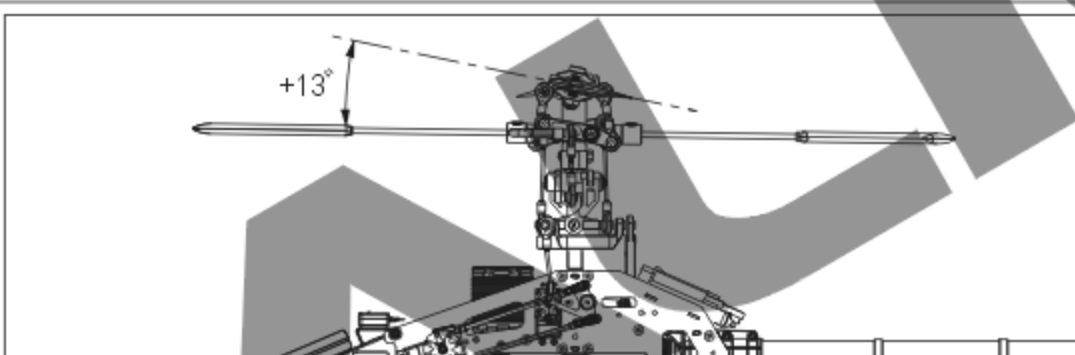

Stick position at high/Throttle 100%/Pitch +13°
搖桿高速/油門100%/Pitch+13°

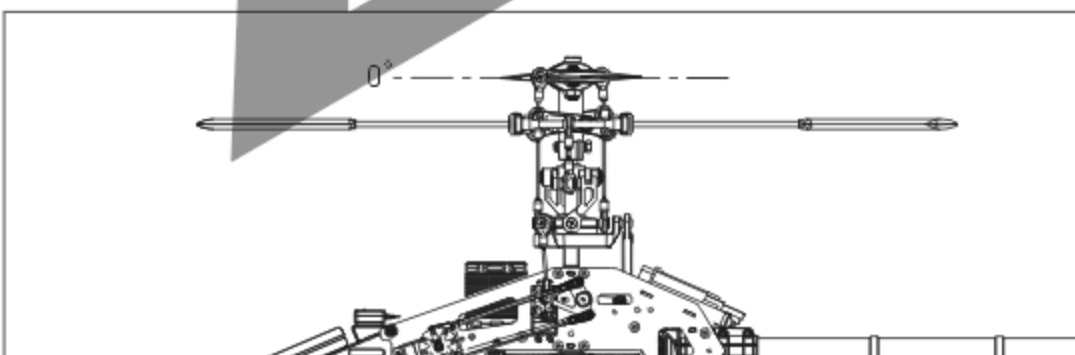

Stick position at middle/Throttle 90%/Pitch 0°
搖桿中速/油門90%/Pitch 0°

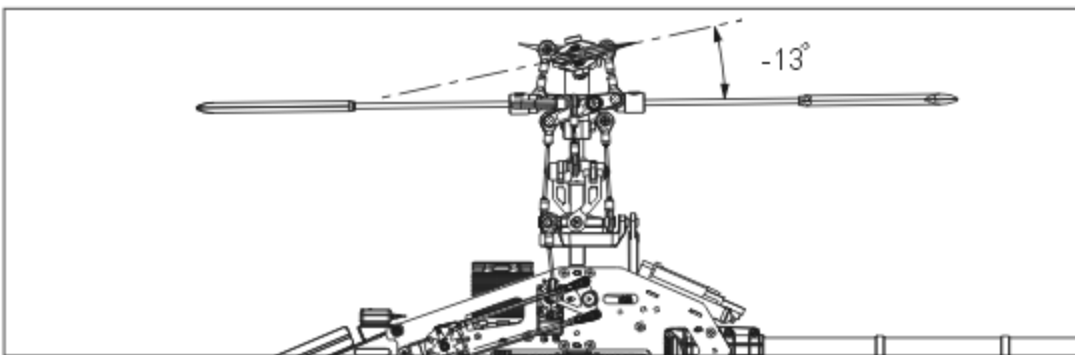

Stick position at low/Throttle 100%/Pitch -13°
搖桿低速/油門100%/Pitch-13°

IDLE 1 : SPORT FLIGHT

	Throttle 油門	Pitch 螺距
5	85%	+10°~+12°
3	80%	+5°
1	85%	-5°

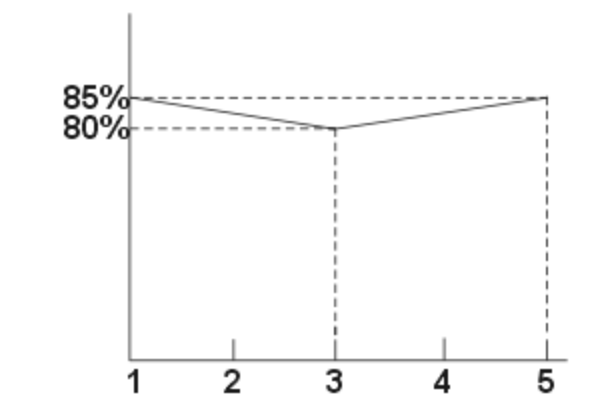

Throttle Curve (Simple Aerobatic Flight)
空中飛行模式油門曲線

IDLE 2 : 3D FLIGHT

	Throttle 油門	Pitch 螺距
5	100% High 100% 高	+13°
3	90% Middle 90% 中	0°
1	100% Low 100% 低	-13°

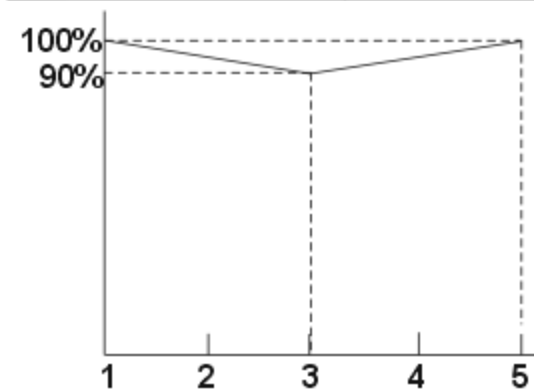

Throttle Curve (3D Flight)
特技飛行模式油門曲線



1. Pitch range : Approx. ±13 degrees.
2. If the pitch is set too high, it will result in shorter flight duration and poor motor performance.
3. Setting the throttle to provide a higher speed is preferable to increasing the pitch too high.
1. 螺距(Pitch)總行程約 ±13°
2. 過大螺距設定，會導致動力與飛行時間降低。
3. 動力提昇以較高轉速的設定方式，優於螺距調大的設定。

Suggested to use 12S Lipo HV (High Voltage) 80 Amp or higher ESC for T-REX 700E. Such as CASTLE ICE HV 80 ESC and KONTRONIK JIVE 80+HV. Suggested the maxium pitch: not exceed 13 degree. Under this circumstance will have a stable 3D flights and avoid the ESC overloading protect activate. Setting the pitch as 13~14 degree doesn't really enhance the efficiency but increasing current, temperature, and shorten the flight time.

If you want to set the maxium pitch to 13~14 degree, suggested to use CASTLE HV 110, CASTLE ICE HV 120, KONTRONIK POWERJIVE 120+HV, and higher ESC to make sure it works property.

T-REX 700E 建議使用規格12S Lipo HV (High Voltage) 80 Amp以上之ESC，使用如CASTLE ICE HV 80 ESC KONTRONIK JIVE 80+HV,建議最大螺距設定勿超過13度，此設定下即有相當不錯的3D飛行特性而且可避免ESC啟動過載保護；最大螺距設定13~14度對整體動力並不會有顯著的提升，反而會增大電流、提高溫升、縮短飛行時間，若要將最大螺距設定至13~14度時，建議使用如 CASTLE HV 110, CASTLE ICE HV 120, KONTRONIK POWERJIVE 120+HV 以上之 ESC，確保ESC正常工作

★ **For CASTLE ICE HV 80 series ESC, please set with choice no. 2: Set current Limiting on "Insensitive", suitable for helicopter mode**

★ CASTLE ICE HV 80 系列 ESC，請將程式設定第二項: Current Limiting 設定在 "Insensitive" 直昇機模式建議選項。

- **Input voltage: DC 7.4V 2cell Lithium battery**
- **Output voltage: DC 5.8V**
- **Max. Continuous Current: 6A**
- **Integrated power switch and voltage indicator meter**
- **Utilizes a linear design, resulting in no interference to the receiver.**
- **Including a 5A 5.1V two-way step-down Voltage Regulator**
- **Size: 60x34x15mm**
- **Weight: 31g (including wire set)**

- 輸入電壓: DC 7.4V 2CELL 鋰電
- 輸出電壓: DC 5.8V
- 最大連續輸出電流: 6安培
- 具電源切換開關與電壓指示燈功能
- 採線性設計，無干擾接收機的缺點
- 附5A 5.1V雙向降壓器
- 尺寸: 60x34x15mm
- 重量: 31g (含線組)

WIRING ILLUSTRATION:

Connect a 5.1V two-way step-down voltage regulator between the gyro and the rudder servo.

接線示意圖：

5.1V 雙向降壓器連接於陀螺儀與尾舵伺服器之間。

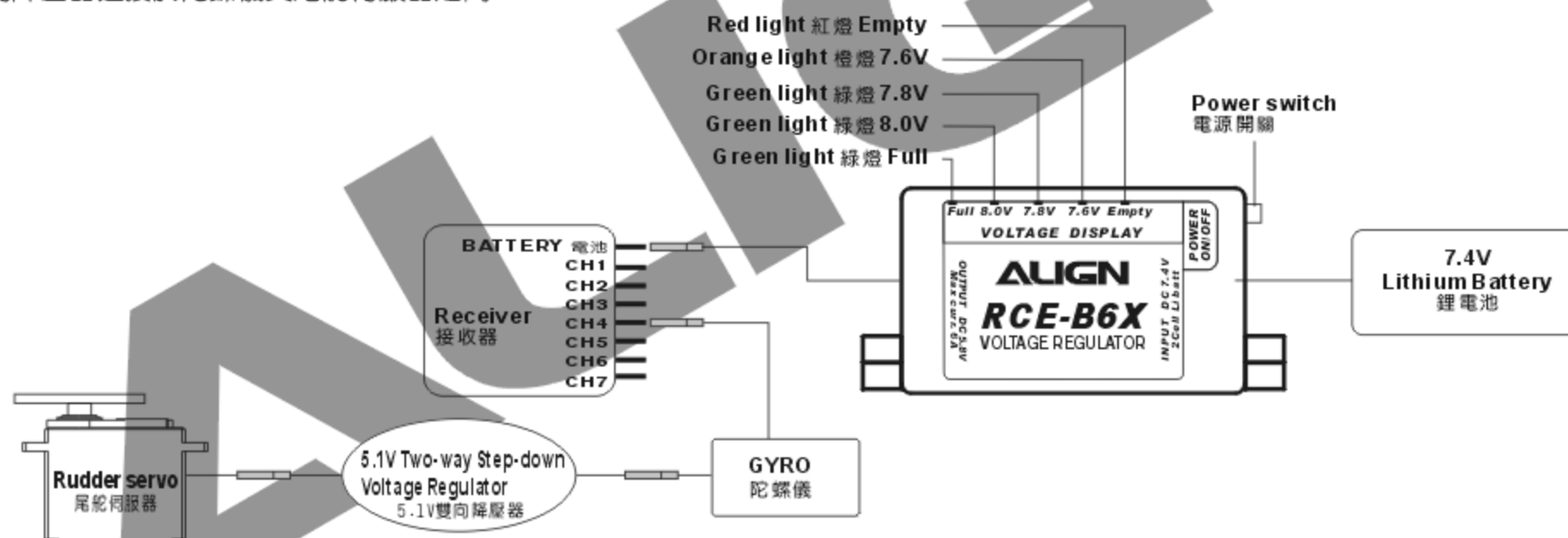

Instruction:

1. **Auto-detecting voltage meter display lights. If the entire five-light array is illuminated, the battery is fully charged. When the voltage drops below 7.6V, the three green lights will be turned off. Use caution, the battery can only be safely used for a single flight. When only the red light is on, the battery voltage is drained, and must be fully recharged before use. Do not attempt to operate the model during this condition!**
 2. **Some servos such as Futaba servo models 9241, 9251, 9253, 9254, 9255, 9256 and other digital servos are not capable of handling 6V. Please connect a 5.1V two-way step-down voltage regulator to avoid the servo damaged. If you are using a servo that can accept 6V input, the regulator is not required.**
 3. **When using a speed controller with BEC output, you must remove the red wire of BEC output on the speed controller.**
 4. **If the receiver does not have enough channels or an available socket, you can use a Y-type servo harness to share any channel with an existing connection.**
1. 本產品具電壓指示功能，當接入充飽的電池時五顆指示燈全亮，表示電池在Full電量充足狀態下；使用中當電壓降低至7.6V時(3顆綠燈熄滅)，尚可完成單趟飛行即須對電池充電或更換新電池；而如果僅亮紅燈時表示Empty電量不足，不應該再使用喔！
2. 部份的伺服器如：Futaba 9241, 9251, 9253, 9254, 9255, 9256等，此類型的伺服器不適合於較高的電壓下操作，所以使用此類型的伺服器時請另外加裝5.1V降壓器，避免伺服器損壞；規格標示准許6V輸入的伺服器則不須使用降壓器。
3. 使用具BEC輸出之調速器時，必須將調速器 BEC 輸出的紅色線拆除！
4. 若接收機已無多餘的電源插孔時，可利用一條伺服 Y 型連接線，接到接收機的任一通道，再將外接 BEC 與拆下的通道一同接在 Y 型線上。

NOTE: When fixing the wire, please do not over tighten to avoid the connector come off or the wire broken when the helicopter rotates (vibration);

do not operate in rain or moisture environment to avoid the electric parts short circuit and damaged.

注意：固定線組時勿將各線組繃緊，以免直昇機運轉時因震動造成接頭鬆脫或斷線；避免在雨中或潮濕的環境下使用，以免造成零件短路而損壞。

BATTERY電池: ALIGN Li-Poly 44.4V 5200mAh

Motor Pinion Gear 馬達齒輪	Main Rotor Blade 主旋翼規格	Pitch 螺距		Current(A) approx. 電流(A)大約值	Throttle Curve 油門曲線	RPM approx. 主旋翼轉速大約值
12T	690 Carbon Fiber Blades 690碳纖主旋翼	Hover 停懸	+5°	15	0/50/60/85/100%	1700~1800
			0°	19	85%Middle中	2240
		Idle	0°	25	100/100/100/100/100%	2440 ⚠
			±12°	59		2250

NOTE: 1. Please use a pitch gauge to adjust the pitch value. Incorrect excess pitch setting will result poor helicopter performance and reduce ESC's life and battery's life.

⚠ 2. For the safeties of flight and helicopter structure, please do not equip the power of main blade over 2200 RPM.

註: 1.請務必使用螺距規來量測調整螺距, 不正確的過大螺距設定不但無法發揮直昇機的特性, 反會影響到無刷調速器與電池的壽命。

⚠ 2.為了飛行安全與機體結構安全, 主旋翼轉速設定禁止超過2200RPM。

RCM-BL700MX MOTOR RCM-BL700MX 無刷馬達

Specification 尺寸規格

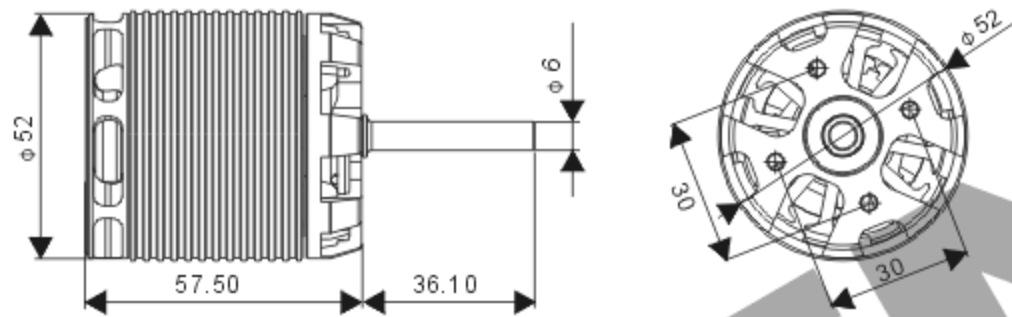

KV	KV值	510KV(RPM/V)	Input voltage	輸入電壓	DC 11.1~50.4V
Stator Arms	矽鋼片槽數	12	Magnet Poles	磁鐵極數	10
Max continuous current	最大持續電流	90A	Max instantaneous current	最大瞬間電流	150A(5sec)
Max continuous power	最大持續功率	4000W	Max instantaneous power	最大瞬間功率	6600W(5sec)
Dimension	尺寸	Shaft 6x52x57.5mm	Weight	重量	Approx. 405g

Illustration 接線示意圖

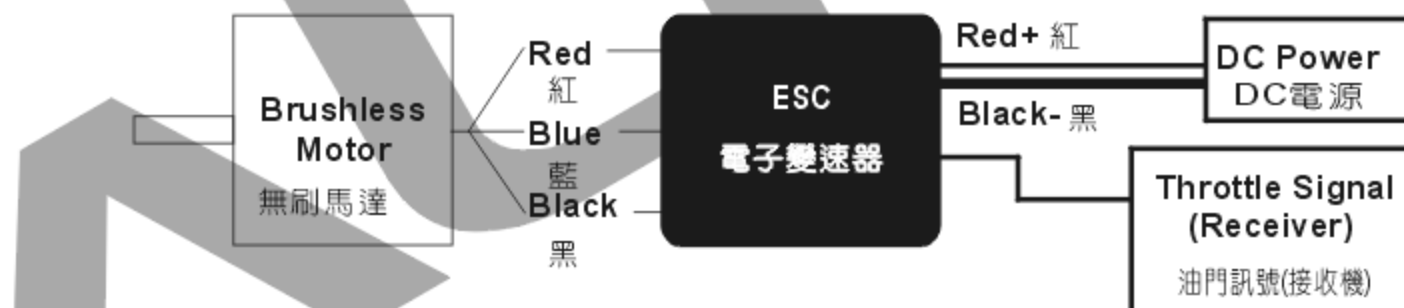

The motor rotates in different direction with different brand ESCs. If the wrong rotating direction happens, please switch any two cables to make the motor rotates in right direction.

由於各品牌電子變速器的馬達啟動轉向不盡相同, 若發生轉向錯誤時, 請將馬達與電子變速器的接線任兩條對調即可。

18.FLIGHT ADJUSTMENT AND SETTING 飛行動作調整與設定

PLEASE PRACTICE SIMULATION FLIGHT BEFORE REAL FLYING 飛行前請事先熟練模擬飛行







Do a simulation flight until you familiarize your fingers with the movements of the rudders, and keep practicing until the fingers move naturally.

1. Place the helicopter in a clear open field (Make sure the power OFF) and the tail of helicopter point to yourself.
2. Practice to operate the throttle stick(as below illustration) and repeat practicing "Throttle high/low", "Aileron left/right", "Rudder left/right", and "Elevator up/down".
- 3.The simulation flight practice is very important, please keep practicing until the fingers move naturally when you hear operation orders being call out.
- 4.Another safe and effective practice method is to use the transmitter flying on the computer through simulator software sold on the market.

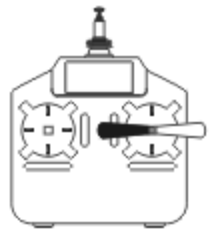
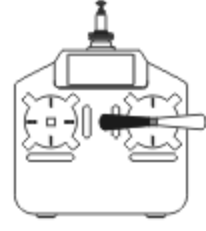

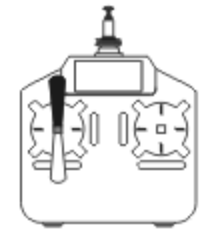
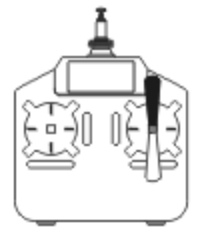
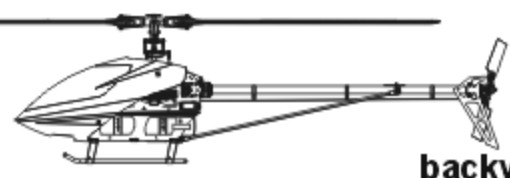
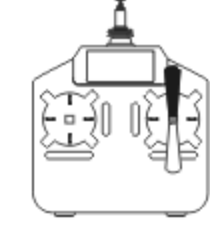
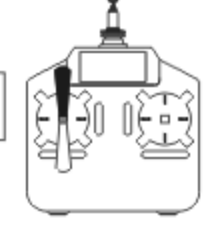
在還沒瞭解直昇機各動作的操控方式前, 嚴禁通電飛行, 請先進行模擬飛行的練習, 並不斷的重複, 直到手指可熟練的控制各個動作及方向。

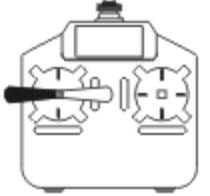
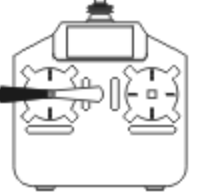
- 1.將直昇機放在空曠的地方(確認電源為關閉), 並將直昇機的機尾對準自己。
- 2.練習操作遙控器的各搖桿(各動作的操作方式如下圖), 並反覆練習油門高/低、副翼左/右、升降舵前/後及方向舵左/右操作方式。
- 3.模擬飛行的練習相當重要, 請重複練習直到不需思索, 手指能自然隨著喊出的指令移動控制。
- 4.另外一種最有效、最安全的練習方式, 就是透過市面販售的模擬軟體, 以遙控器在電腦上模擬飛行, 熟悉各種方向的操控。

Mode 1	Mode 2	Illustration 圖示
 Aileron 副翼		 Move left 左移 ← Move right 右移 → Rotate left 左翻 ↶ Rotate right 右翻 ↷
 Elevator 升降/前後		 Fly forward 前進 ← Fly backward 後退 → Forward rotate 前翻 ↶ backward rotate 後翻 ↷
 Throttle 油門		 Ascent 上升 ↑ Descent 下降 ↓
 Rudder 方向		 Turn right 右旋 ↻ Turn left 左旋 ↻

Flight adjustment and notice 飛行調整與注意

CAUTION 注意

- ⊙ Check if the screws are firmly tightened.
- ⊙ Check if the transmitter and receivers are fully charged.
- ⊙ 再次確認 → 螺絲是否鎖固?
- ⊙ 發射器和接收器電池是否足夠。

CAUTION 注意

If there are other radio control aircraft at the field, make sure to check their frequencies and tell them what frequency you are using. Frequency interference can cause your model, or other models to crash and increase the risk of danger. 假使飛行場有其他遙控飛機，請確認他們的頻率，並告知他們你正在使用的頻率，相同的頻率會造成干擾導致失控和大大地增加風險。

- ★ When arriving at the flying field.
- ★ 當抵達飛行場

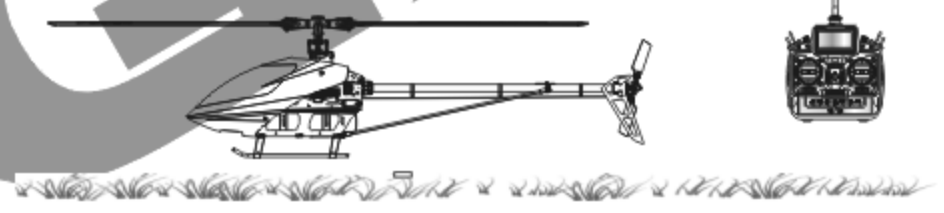

STARTING AND STOPPING THE MOTOR 啟動和停止馬達

CAUTION 注意

First check to make sure no one else is operating on the same frequency. Then place the throttle stick at lowest position and turn on the transmitter. 首先確認附近沒有其他相同頻率的使用，然後打開發射器將油門搖桿推到低點。

CAUTION 注意

Check if the throttle stick is set at the lowest position. 確認油門搖桿是在最低的位置。

Mode 1 Mode 2

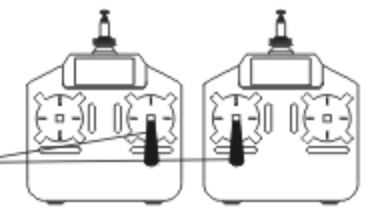

- ★ Check the movement.
- ★ 動作確認



ON! Step1
First turn on the transmitter.
先開啟發射器

- ⊙ Are the rudders moving according to the controls?
- ⊙ Follow the transmitter's instruction manual to do a range test.
- ⊙ 方向舵是否隨著控制方向移動?
- ⊙ 根據發射器說明書進行距離測試。



ON! Step2
Connect to the helicopter power
接上直昇機電源



OFF! Step3
Reverse the above orders to turn off.
關閉電源時請依上述操作動作反執行。

Main rotor adjustments 主旋翼雙槳平衡調整

CAUTION 注意

Tracking adjustment is very dangerous, so please keep away from the helicopter at a distance of at least 10m. 調整軌跡非常危險，請於距離飛機最少10公尺的距離。

1. Before adjusting, apply a red piece of tape on one blade, or paint a red stripe with a marker or paint to identify on blade.
2. Raise the throttle stick slowly and stop just before the helicopter lifts-off ground. Look at the spinning blades from the side of the helicopter.
3. Look at the path of the rotor carefully. If the two blades rotate in the same path, it does not need to adjustment. If one blade is higher or lower than the other blade, adjust the tracking immediately.

1. 調整前先在其中一支主旋翼的翼端，貼上有顏色的貼紙或畫上顏色記號，方便雙槳調整辨識。
2. 慢慢的推起油門搖桿到高點並目停止，在飛機離開地面前，從飛機側邊觀察主旋翼轉動。
3. 仔細觀察旋翼軌跡(假如兩支旋翼移動都是相同軌跡，則不需要調整;可是如果一支旋翼較高或較低產生“雙槳”的情形時，則必須立刻調整軌跡)。

- A. When rotating, the blade with higher path means the pitch too big. linkage rod (C) for slight pitch trim.**
B. When rotating, the blade with lower path means the pitch too small. linkage rod (C) for slight pitch trim.

A. 旋翼轉動時較高軌跡的主旋翼表示螺距 (PITCH) 過大，請調短連桿 (C) 修正。
 B. 旋翼轉動時較低軌跡的主旋翼表示螺距 (PITCH) 過小，請調長連桿 (C) 修正。



Incorrect tracking may cause vibrations. Please repeat adjusting the tracking to make sure the rotor is correctly aligned. After tracking adjustment, please check the pitch angle is approx. 5° when hovering.

不正確的旋翼軌跡會導致震動，請不斷重複調整軌跡，使旋翼軌跡精準正確。
 在調整軌跡後，確認一下Pitch角度在停旋時應為大約5°。

FLIGHT ADJUSTMENT AND NOTICE FOR BEGINNERS 初學飛行調整與注意

- During the operation of the helicopter, please stand approximately 10m diagonally behind the helicopter.
- 飛行時，請站在直昇機後方最少10公尺。



- Make sure that no one or obstructions in the vicinity.
- For flying safety, please carefully check if every movement and directions are correct when hovering.
- 確認鄰近地區沒有人和障礙物。
- 為了飛行安全，您必須先確認停懸時各項操控動作是否正常。



Do not attempt until you have some experiences with the operation of helicopter.
 嚴禁無熟練操控飛行經驗者操控飛行。

STEP 1 THROTTLE CONTROL PRACTICE 油門控制練習

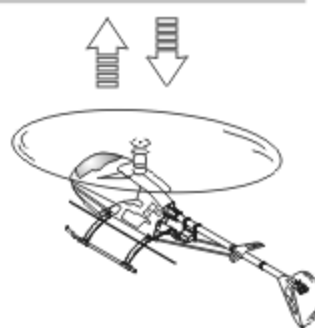
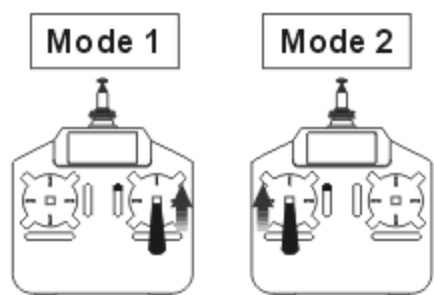

- When the helicopter begins to lift-off the ground, slowly reduce the throttle to bring the helicopter back down. Keep practicing this action until you control the throttle smoothly.
- 當直昇機開始離地時，慢慢降低油門將飛機降下。持續練習飛機從地面上升和下降直到你覺得油門控制很順。

STEP 2 AILERON AND ELEVATOR CONTROL PRACTICE 副翼和升降控制練習

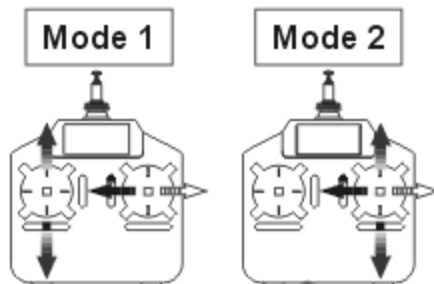

- Raise the throttle stick slowly.
- Move the helicopter in any direction back, forward, left and right, slowly move the aileron and elevator sticks in the opposite direction to fly back to its original position.

1. 慢慢升起油門搖桿。
 2. 使直昇機依指示：移動向後/向前/向左/向右，慢慢的反向移動副翼和升降搖桿並將直昇機開回到原來位置。

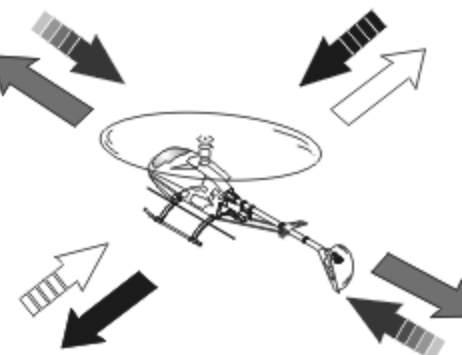

- If the nose of the helicopter moves, please lower the throttle stick and land the helicopter. Then move your position diagonally behind the helicopter 10m and continue practicing.
- If the helicopter flies too far away from you, please land the helicopter and move your position behind 10m and continue practicing.
- 當直昇機機頭偏移時，請降低油門並且降落，然後移動自己的位置到直昇機的正後方10公尺再繼續練習。
- 假如直昇機飛離你太遠，請先降落直昇機，並到直昇機後10公尺再繼續練習。

STEP 3 RUDDER CONTROL PRACTICING 方向舵操作練習

- Slowly raise the throttle stick.
- Move the nose of the helicopter to right or left, and then slowly move the rudder stick in the opposite direction to fly back to its original position.

1. 慢慢升起油門搖桿。
 2. 將直昇機機頭移動左或右，然後慢慢反向移動方向舵搖桿並將直昇機飛回原本位置。

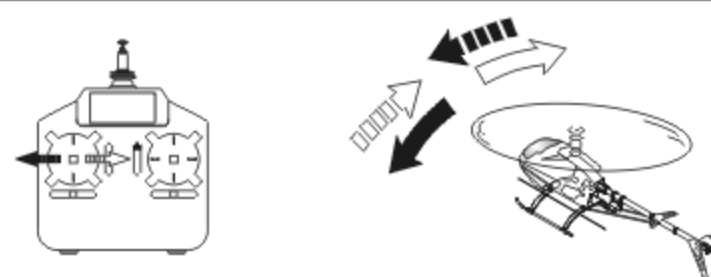

STEP 4

After you are familiar with all actions from Step1 to 3, draw a circle on the ground and practice within the circle to increase your accuracy.

當你覺得 step1~3 動作熟悉了，在地上畫圈圈並在這個圈圈的範圍內練習飛行，以增加你操控的準確度。

- You can draw a smaller circle when you get more familiar with the actions.
- 當你更加習慣操作動作，你可以畫更小的圈圈。

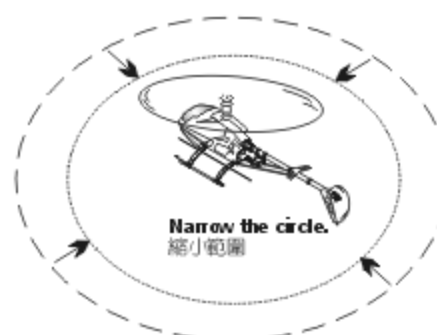

STEP 5 DIRECTION CHANGE AND HOVERING PRACTICE 改變直昇機方向和練習停旋

After you are familiar with Step1 to 4, stand at side of the helicopter and continue practicing Step1 to 4. Then repeat the Step1 to 4 by standing right in front of the helicopter.

當你覺得step1-4動作熟悉了，站在面對直昇機側邊並繼續練習step1-4。之後，站在直昇機機頭右邊重複步驟練習。

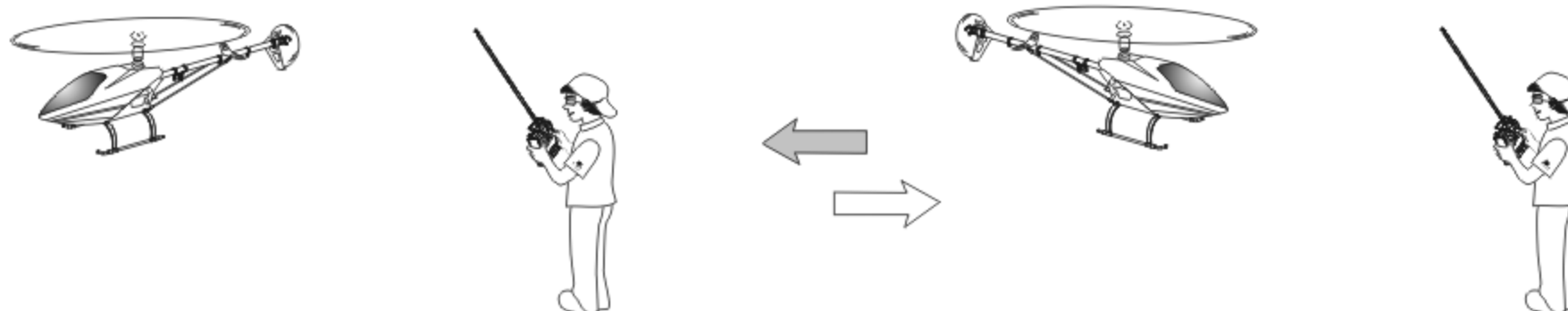

ADJUSTMENT OF EACH TRIM 飛行動作微調

Slowly raise the throttle stick and just as the helicopter lift-off the ground, you can use the trim to correct the action if the helicopter leans in a different direction.

慢慢升起油門搖桿，當直昇機剛剛離開地面時，若直昇機傾向不同方向，可使用微調修正動作。

1. Adjustment of rudder trim 調整方向舵微調

Just before the helicopter lift-off, the nose lean left/right...
When leans right, adjust the trim to left side.
When leans left, adjust the trim to right side.

在直昇機正要起飛時，機頭朝左/右方向偏移...
向右偏移時，微調向左調整。
向左偏移時，微調向右調整。

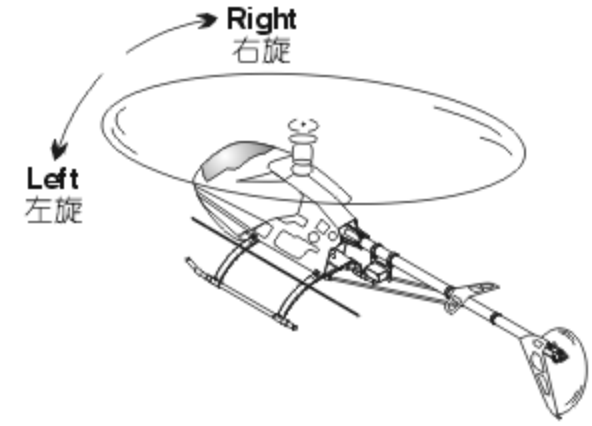
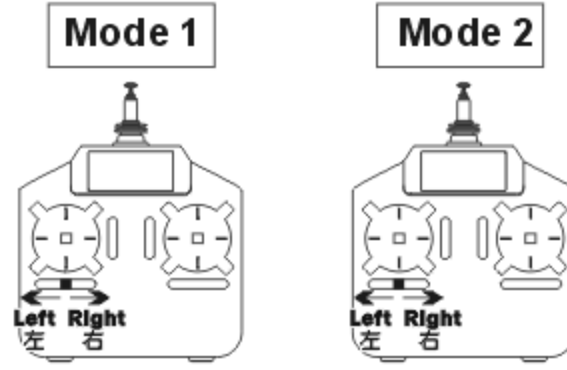

2. Adjustment of elevator trim 調整升降舵微調

Just before the helicopter lift-off, the nose lean forward/backward...
When leans forward, adjust the trim down.
When leans backward, adjust the trim up.

在直昇機正要起飛時，機頭朝前/後方向偏移...
向前偏移時，微調向下調整。
向後偏移時，微調向上調整。

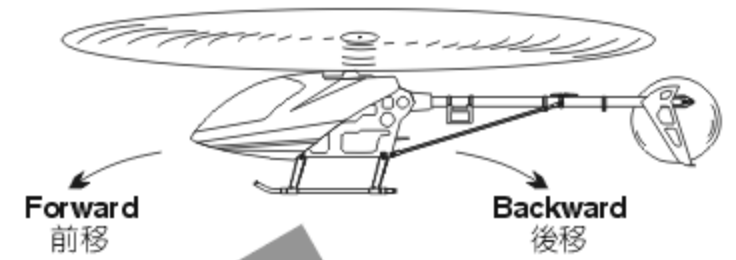
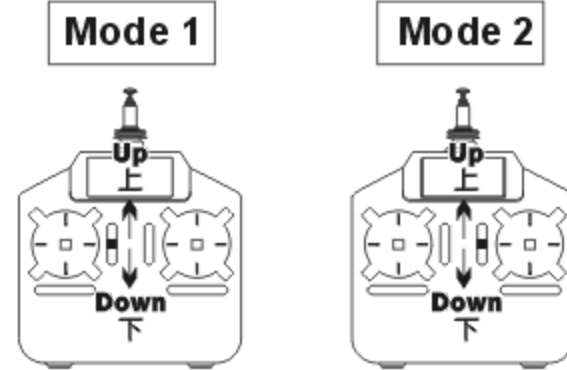

3. Adjustment of Aileron trim 調整副翼微調

Just before the helicopter lift-off, the body lean left/right...
When leans right, adjust the trim to left side.
When leans left, adjust the trim to right side.

在直昇機正要起飛時，機身朝左/右方向偏移...
向右偏移時，微調向左調整。
向左偏移時，微調向右調整。

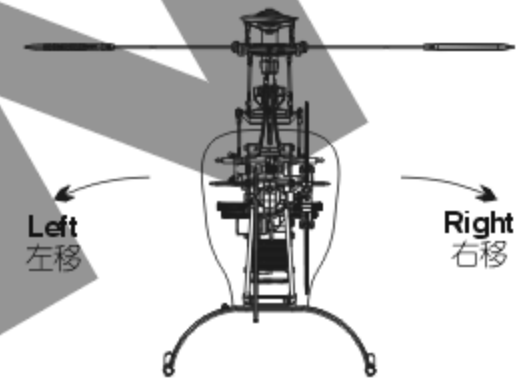
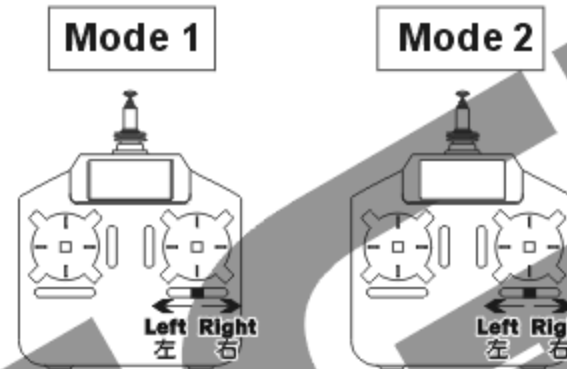

TROUBLE SHOOTING DURING FLIGHT 如何排除飛行中的狀況

	Situation 狀況	Cause 原因	Way to deal 對策
Blade Tracking 雙槳平衡	Out of tracking 雙槳	Adjustment of pitch rod has not been done. PITCH連桿長度調整不平均	Adjust the length of linkage rod(C) 調整連桿(C)長度
During Hovering 停旋	Low rotation of the rotor 主旋翼轉速偏低	★Pitch of main blade is high. ★主旋翼的PITCH偏高 ★Throttle curve is too low during hovering. ★停旋點油門曲線過低	★Lower the pitch about 4~5 during hovering(The rotation should be about 1700~1800rpm during hovering). ★調低Pitch停旋pitch約4°-5°(停旋時主旋翼需為約1700-1800RPM) ★Heighten the throttle curve during hovering. ★調高停旋點油門曲線
	High rotation of the rotor 主旋翼轉速偏高	★Pitch of main blade is low. ★主旋翼的PITCH偏低 ★Throttle curve is too high during hovering. ★停旋點油門曲線過高	★Adjust the pitch rod <C> (The rotation should be about 1700~1800rpm during hovering). ★調整連桿 <C> (停旋時主旋翼需為約1700-1800RPM) ★Lower the throttle curve during hovering. ★調低停旋點油門曲線
Sensitivity of the gyro 陀螺儀感度	The tail leans to one side during hovering, or when trim the rudder and return to the neutral, the tail lags and cannot stay in a control position. 停旋時尾翼向某一邊偏移，或撥動方向舵並回復到中立點時，尾翼產生延遲，無法停頓在所控制位置上。	★Failure setting of tail neutral point. ★尾中立點設定不當 ★The sensitivity of the gyro is low. ★陀螺儀感度偏低	★Reset tail neutral point. ★重設尾中立點 ★Increase the sensitivity. ★增加感度
	The tail wags left and right during flight at hovering or full speed. 停懸或全油門時尾翼左右來回快速搖擺。	The sensitivity of the gyro is high. 陀螺儀感度偏高	Decrease the sensitivity. 降低感度

※If the problem is still there even after tried above, stop flying and contact with your seller.

※在做完以上調整後，仍然無法改善情況時，應立即停止飛行並連絡您的經銷商。

ALIGN

Specifications & Equipment/規格配備:

Length/機身長: 1328mm

Height/機身高: 415mm

Main Blade Length/主旋翼長: 690mm

Main Rotor Diameter/主旋翼直徑: 1562mm

Tail Rotor Diameter/尾旋翼直徑: 281mm

Motor Drive Gear/馬達齒輪: 12T

Main Drive Gear/主齒輪: 115T

Autorotation Tail Drive Gear/尾驅動主齒: 104T

Drive Gear Ratio/齒輪傳動比: 1:9.58:4.33

Weight(With Motor)/空機重(含馬達): 2975g

Flying Weight/全配重: Approx. 4800g

