

# Combo T-REX 700E INSTRUCTION MANUAL 使用說明書 KX018E02T

# ALIGN

Programmable  
**3G**  
Flybarless System

Contents	
1	INTRODUCTION 前言
1~2	SAFETY NOTES 安全注意事項
3	EQUIPMENT REQUIRED FOR ASSEMBLY 自備設備
3	PACKAGE ILLUSTRATION 包裝說明
4	SAFETY CHECK BEFORE FLYING 飛行前安全檢查
5~16	ASSEMBLY SECTION 組裝說明
17	EQUIPMENT INSTALLATION 各項設備配置圖
18	BATTERY INSTALLATION ILLUSTRATION 電池安裝示意圖
18	CANOPY ASSEMBLY 機頭罩安裝
19	ELECTRIC EQUIPMENT ILLUSTRATION 電子設備建議配置圖示
20	SERVO SETTING AND ADJUSTMENT 伺服器設定調整
20	ADJUSTMENTS FOR GYRO AND TAIL NEUTRAL SETTING 陀螺儀與尾翼中立點調整
21	PITCH AND THROTTLE SETTING 主旋翼螺距與油門設定
22~29	3G FLYBARLESS FL760 MANUAL 無平衡翼系統使用說明
29~30	RCM-BL700M 510KV POWER COLLOCATION REFERENCE 原裝動力數據參考表
30	SUGGESTIONS FOR ESC SETTING ESC無刷調速器設定建議說明
31~32	3G FLYBARLESS PREFLIGHT CHECK 飛行前測試程序
32~35	FLIGHT ADJUSTMENT AND SETTING 飛行動作調整與設定
36	3G FLYBARLESS FLIGHT TEST PROCEDURE 飛行測試程序
36	SETUP EXAMPLES 飛行特性設定對照表
37	TROUBLESHOOTING 飛行中狀況排除
38	Q & A 問與答



3Axis SMM i2bit Easy Energy Stable 300Hz 3V-8.4V 25g RoHS

Thank you for buying ALIGN products. The **T-REX 700E 3G** is the latest technology in Rotary RC models. Please read this manual carefully before assembling and flying the new **T-REX 700E 3G** helicopter. We recommend that you keep this manual for future reference regarding tuning and maintenance.

承蒙閣下選用亞拓遙控世界系列產品，謹表謝意。進入遙控世界之前必須告訴您許多相關的知識與注意事項，以確保您能夠在學習的過程中較得心應手。在開始操作之前，請務必詳閱本說明書，相信一定能夠給您帶來相當大的幫助，也請您妥善保管這本說明書，以作為日後參考。

**Thank you for buying ALIGN Products. The T-REX 700E 3G Helicopter is designed as an easy to use, full featured Helicopter R/C model capable of all forms of rotary flight. Please read the manual carefully before assembling the model, and follow all precautions and recommendations located within the manual. Be sure to retain the manual for future reference, routine maintenance, and tuning.**

**The T-REX 700E 3G is a new product developed by ALIGN. It provides flying stability for beginners, full aerobatic capability for advanced fliers, and unsurpassed reliability for customer support.**

感謝您選購亞拓產品，為了讓您容易方便的使用 T-REX 700E 3G 直昇機、請您詳細的閱讀完這本說明書之後再進行組裝以及操作這台直昇機，同時請您妥善的保存這本說明書，作為日後進行調整以及維修的參考。

T-REX 700E 3G 是由亞拓自行研發的新產品，不論你是需求飛行穩定性的初學者或是追求性能的飛行愛好者，T-REX 700E 3G 將是你最佳的選擇。

### THE MEANING OF SYMBOLS 標誌代表涵義

 <b>WARNING</b> 警告	<b>Mishandling due to failure to follow these instructions may result in damage or injury.</b> 因為疏忽這些操作說明，而使用錯誤可能造成財產損失或嚴重傷害。
 <b>CAUTION</b> 注意	<b>Mishandling due to failure to follow these instructions may result in danger.</b> 因為疏忽這些操作說明，而使用錯誤可能造成危險。
 <b>FORBIDDEN</b> 禁止	<b>Do not attempt under any circumstances.</b> 在任何禁止的環境下，請勿嘗試操作。

### IMPORTANT NOTES 重要聲明

**R/C helicopters, including the T-REX 700E 3G are not toys. R/C helicopter utilize various high-tech products and technologies to provide superior performance. Improper use of this product can result in serious injury or even death. Please read this manual carefully before using and make sure to be conscious of your own personal safety and the safety of others and your environment when operating all ALIGN products.**

**Manufacturer and seller assume no liability for the operation or the use of this product. Intended for use only by adults with experience flying remote control helicopters at a legal flying field. After the sale of this product we cannot maintain any control over its operation or usage.**

T-REX 700E 3G 遙控直昇機並非玩具，它是結合了許多高科技產品所設計出來的休閒用品，所以商品的使用不當或不熟悉都可能造成嚴重傷害甚至死亡，使用之前請務必詳讀本說明書，勿輕忽並注意自身安全。

注意！任何遙控直昇機的使用，製造商和經銷商是無法對使用者於零件使用的損耗異常或組裝不當所發生之意外負任何責任，本產品是提供給有操作過模型直昇機經驗的成人，或有相當技術的人員在旁指導於當地合法遙控飛行場飛行，以確保安全無虞下操作使用。產品售出後本公司將不負任何操作和使用控制上的任何性能與安全責任。

**We recommend that you obtain the assistance of an experienced pilot before attempting to fly our products for the first time. A local expert is the best way to properly assemble, setup, and fly your model for the first time. The Helicopter requires a certain degree of skill to operate, and is a consumer item. Any damage or dissatisfaction as a result of accidents or modifications are not covered by any warrantee and cannot be returned for repair or replacement. Please contact our distributors for free technical consultation and parts at discounted rates when you experience problems during operation or maintenance.**

模型商品屬於需高操作技術且為消耗性之商品，如經拆裝使用後，會造成不等情況零件損耗，任何使用情況所造成商品不良或不滿意，將無法於保固條件內更換新品或退貨，如遇有使用操作維修問題，本公司全省分公司或代理商將提供技術指導、特價零件供應服務。

## 2.SAFETY NOTES 安全注意事項



**Fly only in safe areas, away from other people. Do not operate R/C aircraft within the vicinity of homes or crowds of people. R/C aircraft are prone to accidents, failures, and crashes due to a variety of reasons including, lack of maintenance, pilot error, and radio interference. Pilots are responsible for their actions and damage or injury occurring during the operation or as of a result of R/C aircraft models.**

遙控模型飛機、直昇機屬高危險性商品，飛行時務必遠離人群，人為組裝不當或機件損壞、電子控制設備不良，以及操控上的不熟悉、都有可能導致飛行失控損傷等不可預期的意外，請飛行者務必注意飛行安全，並需了解自負疏忽所造成任何意外之責任。



### LOCATE AN APPROPRIATE LOCATION 遠離障礙物及人群

R/C helicopters fly at high speed, thus posing a certain degree of potential danger. Choose a legal flying field consisting of flat, smooth ground without obstacles.

Do not fly near buildings, high voltage cables, or trees to ensure the safety of yourself, others and your model.

For the first practice, please choose a legal flying field and can use a training skid to fly for reducing the damage. Do not fly your model in inclement weather, such as rain, wind, snow or darkness.

直昇機飛行時具有一定的速度，相對的也潛在著危險性，場地的選擇也相對的重要，請需遵守當地法規到合法搖控飛行場地飛行。

必須注意周遭有沒有人、高樓、建築物、高壓電線、樹木等等，避免操控的不當造成自己與他人財產的損壞。

初次練習時，務必選擇在空曠合法專屬飛行場地並適當搭配練習架練習飛行，這對飛行失誤所造成的損傷將會大幅的降低。請勿在下雨、打雷等惡劣天候下操作，以確保本身及機體的安全。



### PREVENT MOISTURE 遠離潮濕環境

R/C models are composed of many precision electrical components.

It is critical to keep the model and associated equipment away from moisture and other contaminants. The introduction or exposure to water or moisture in any form can cause the model to malfunction resulting in loss of use, or a crash. Do not operate or expose to rain or moisture.

直昇機內部也是由許多精密的電子零組件組成，所以必須絕對的防止潮濕或水氣，避免在浴室或雨天時使用，防止水氣進入機身內部而導致機件及電子零件故障而引發不可預期的意外！



### PROPER OPERATION 勿不當使用本產品

Please use the replacement of parts on the manual to ensure the safety of instructors.

This product is for R/C model, so do not use for other purpose.

請勿自行改造加工，任何的升級改裝或維修，請使用亞拓產品目錄中的零件，以確保結構的安全。請確認於產品限界內操作，請勿過載使用，並勿用於安全、法令外其它非法用途。



### OBTAIN THE ASSISTANCE OF AN EXPERIENCED PILOT 避免獨自操控

Before turning on your model and transmitter, check to make sure no one else is operating on the same frequency. Frequency interference can cause your model, or other models to crash.

The guidance provided by an experienced pilot will be invaluable for the assembly, tuning, trimming, and actual first flight.

(Recommend you to practice with computer-based flight simulator.)

至飛行場飛行前，需確認是否有相同頻率的同好正進行飛行，因為開啓相同頻率的發射機將導致自己與他人立即干擾等意外危險。

遙控飛機操控技巧在學習初期有著一定的難度，要盡量避免獨自操作飛行，需有經驗的人士在旁指導，才可以操控飛行。(勤練電腦模擬器及老手指導是入門必要的選擇)



### SAFE OPERATION 安全操作

Operate this unit within your ability. Do not fly under tired condition and improper operation may cause in danger.

請於自己能力內及需要一定技術範圍內操作這台直昇機，過於疲勞、精神不佳或不當操作，意外發生風險將可能會提高。



### ALWAYS BE AWARE OF THE ROTATING BLADES 遠離運轉中零件

During the operation of the helicopter, the main rotor and tail rotor will be spinning at a high rate of speed. The blades are capable of inflicting serious bodily injury and damage to the environment. Be conscious of your actions, and careful to keep your face, eyes, hands, and loose clothing away from the blades. Always fly the model a safe distance from yourself and others, as well as surrounding objects. Never take your eyes off the model or leave it unattended while it is turned on. Immediately turn off the model and transmitter when you have landed the model.

當直昇機主旋翼與尾旋翼運轉時，切勿觸摸並遠離任何物件，以避免造成危險及損壞。



### KEEP AWAY FROM HEAT 遠離熱源

R/C models are made up various forms of plastic. Plastic is very susceptible to damage or deformation due to extreme heat and cold climate. Make sure not to store the model near any source of heat such as an oven, or heater. It is best to store the model indoors, in a climate-controlled, room temperature environment.









遙控飛機多半是以 PA 纖維或聚乙烯、電子商品為主要材質，因此要盡量遠離熱源、日曬，以避免因高溫而變形甚至熔毀損壞的可能。



#### RADIO TRANSMITTER AND ELECTRONIC EQUIPMENT REQUIRED FOR ASSEMBLY 自備遙控及電子設備

 <p><b>Transmitter</b> (7-channel or more, helicopter system) 發射機(七動以上直昇機模式遙控器)</p>	 <p><b>Receiver(7-channel or more)</b> 接收機(七動以上)</p>
 <p><b>22.2V 6S 4500~5200mAh Li-Po Battery x 2pc</b> 22.2V 6S 4500~5200mAh Li-Po電池 x 2</p>	 <p><b>Dial Pitch Gauge x 1pc</b> 旋轉式螺距規 x 1</p>
 <p><b>Li-Po Battery Charger</b> Li-Po電池充電器</p>	 <p><b>ESC (Li-Po 12S 80A or more)</b> Li-Po 12S 80A以上ESC x 1</p>

#### ADDITIONAL TOOLS REQUIRED FOR ASSEMBLY 自備工具

 <p><b>Scissors</b> 剪刀</p>	 <p><b>Cutter Knife</b> 刀子</p>	 <p><b>Diagonal Cutting Pliers</b> 斜口鉗</p>	 <p><b>Needle Nose Pliers</b> 尖嘴鉗</p>
 <p><b>Oil</b> 潤滑油</p>	 <p><b>CA</b> 瞬間膠</p>	 <p><b>Hexagon Screw Driver</b> 六角螺絲起子 3mm/2.5mm/2mm/1.5mm</p>	 <p><b>Philips Screw Driver</b> 十字螺絲起子 φ 3.0/φ 1.8mm</p>

### 4.PACKAGE ILLUSTRATION 包裝說明

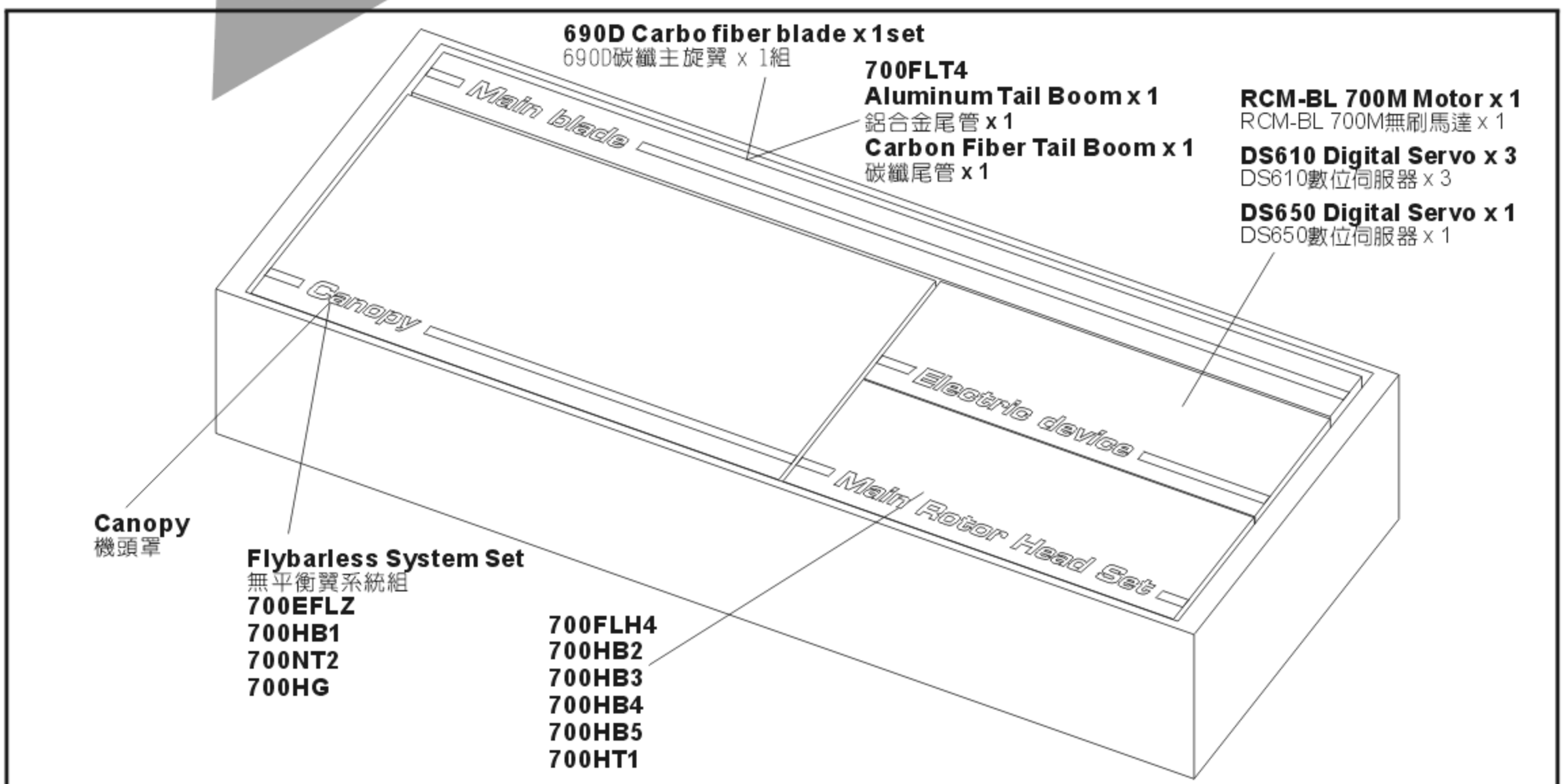

## CAREFULLY INSPECT BEFORE REAL FLIGHT 請嚴格執行飛行前之檢查義務

- ☆ Before flying, please check to make sure no one else is operating on the same frequency for the safety.
- ☆ Before flight, please check if the batteries of transmitter and receiver are enough for the flight.
- ☆ Before turn on the transmitter, please check if the throttle stick is in the lowest position. IDLE switch is OFF.
- ☆ When turn off the unit, please follow the power on/off procedure. Power ON- Please turn on the transmitter first, and then turn on receiver. Power OFF- Please turn off the receiver first and then turn off the transmitter. Improper procedure may cause out of control, so please to have this correct habit.
- ☆ Before operation, check every movement is smooth and directions are correct. Carefully inspect servos for interference and broken gear.
- ☆ Check for missing or loose screws and nuts. See if there is any cracked and incomplete assembly of parts. Carefully check main rotor blades and rotor holders. Broken and premature failures of parts possibly cause resulting in a dangerous situation.
- ☆ Check all ball links to avoid excess play and replace as needed. Failure to do so will result in poor flight stability.
- ☆ Check if the battery and power plug are fastened. Vibration and violent flight may cause the plug loose and result out of control.
- ☆ Be sure to use the carbon fiber main rotor blades durable with 2800RPM(or faster) 690mm length. Please do not use the carbon fiber main rotor blades with durability lower than 2800RPM and wooden or glass fiber main blades to avoid any unpredictable damage.

- ★ 每次飛行前應先確認所使用的頻率是否會干擾他人，以確保你自身與他人的安全。
- ★ 每次飛行前確定您發射機與接收機電池的電量是在足夠飛行的狀態。
- ★ 開機前確認油門搖桿是否位於最低點，熄火降落開關，定速開關(IDLE)是否於關閉位置。
- ★ 關機時必須遵守電源開關機的程序，開機時應先開啓發射機後，再開啓接收機電源；關機時應先關閉接收機後，再關閉發射機電源。不正確的開關程序可能會造失控的現象，影響自身與他人的安全，請養成正確的習慣。
- ★ 開機請先確定直昇機的各個動作是否順暢，及方向是否正確，並檢查伺服器的動作是否有干涉或崩齒的情形，使用故障的伺服器將導致不可預期的危險。
- ★ 飛行前確認沒有缺少或鬆脫的螺絲與螺帽，確認沒有組裝不完整或損毀的零件，仔細檢查主旋翼是否有損壞，特別是接近主旋翼夾座的部位。損壞或組裝不完整的零件不僅影響飛行，更會造成不可預期的危險。注意：每次飛行前的安全檢查、保養、及更換損耗零件，請確實嚴格執行以確保安全。
- ★ 檢查所有的連桿頭是否有鬆脫的情形，過鬆的連桿頭應先更新，否則將造成直昇機無法操控的危險。
- ★ 確認電池及電源接頭是否固定牢靠，飛行中的震動或激烈的飛行，可能造成電源接頭鬆脫而造成失控的危險。
- ★ 主旋翼務必使用耐轉速2800RPM以上的 690mm長度碳纖維，嚴禁使用耐轉速低於2800RPM的碳纖維、玻纖維或木製槳。

### Standard Equipment 標準配備

 <b>700HC</b>	 <b>700FLH4</b>	 <b>700HB1</b>	 <b>700HB2</b>	 <b>700HB3</b>	 <b>700HB4</b>	 <b>700HB5</b>
 <b>700HG</b>	 <b>700HT1</b>	 <b>700NT2</b>	 <b>700FLT4</b> Aluminum Tail Boom x 1 鋁合金尾管 x 1 Carbon Fiber Tail Boom x 1 碳纖維尾管 x 1	 <b>700EFLZ</b>	 <b>690D Carbon Fiber Blades x 1set</b> 690D碳纖主旋翼 x 1組	
 <b>RCM-BL 700M 510KV Brushless motor x 1</b> RCM-BL 700M 510KV無刷馬達 x 1		 <b>DS610 Digital Servo x 3</b> DS610數位伺服器 x 3 <b>CNC Metal servo horn</b> CNC金屬伺服器舵角片 x 3		 <b>DS650 Digital Servo x 1</b> DS650數位伺服器 x 1		 <b>Flybarless System FL760</b> 700無平衡翼系統組

When you see the marks as below, please use glue or grease to ensure flying safety.

標有以下符號之組裝步驟，請配合上膠或上油，以確保使用之可靠度。



- CA : Apply CA Glue to fix.**
- R48 : Apply Anaerobics Retainer to fix.**
- T43 : Apply Thread Lock to fix.**
- OIL : Add Grease.**
- CA : 使用瞬間膠固定
- R48 : 使用金屬管狀固定缺氧膠固定
- T43 : 使用螺絲膠
- OIL : 添加潤滑油

When assembling ball links, make sure the "A" character faces outside.

各項塑膠製連桿頭扣接時，A字請朝外。



Grease  
潤滑油



R48  
綠色



T43  
藍色



CA  
Self-furnished  
瞬間膠(自備)

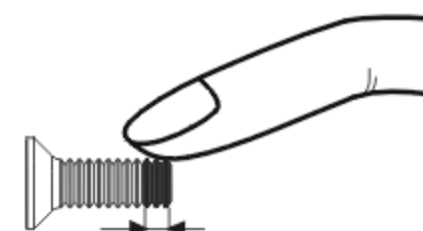

T43 Glue width : approx. 1mm  
T43上膠寬度約1mm

**R48 metal tubular adhesive (eg. Bearings). T43 thread lock, apply a small amount on screws or metal parts and wipe surplus off. When disassembling, recommend to heat the metal joint about 15 Seconds. (NOTE : Keep plastic parts away from heat.)**

R48 為強力金屬管狀(如軸承)接著劑，T43為螺絲膠，膠合螺絲或金屬內外徑請務必少量使用，必要時請用手去除多餘膠量，欲拆卸時可於金屬接合部位熱烤約15秒。(注意！塑膠件避免接近熱源)

700FLH3



700FLH3A

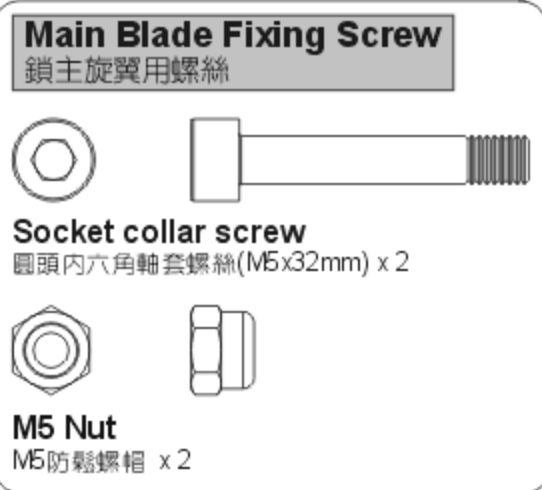

Apply a little amount of T43 thread lock when fixing a metal part.  
螺絲鎖附於金屬件請使用適量T43(螺絲膠)

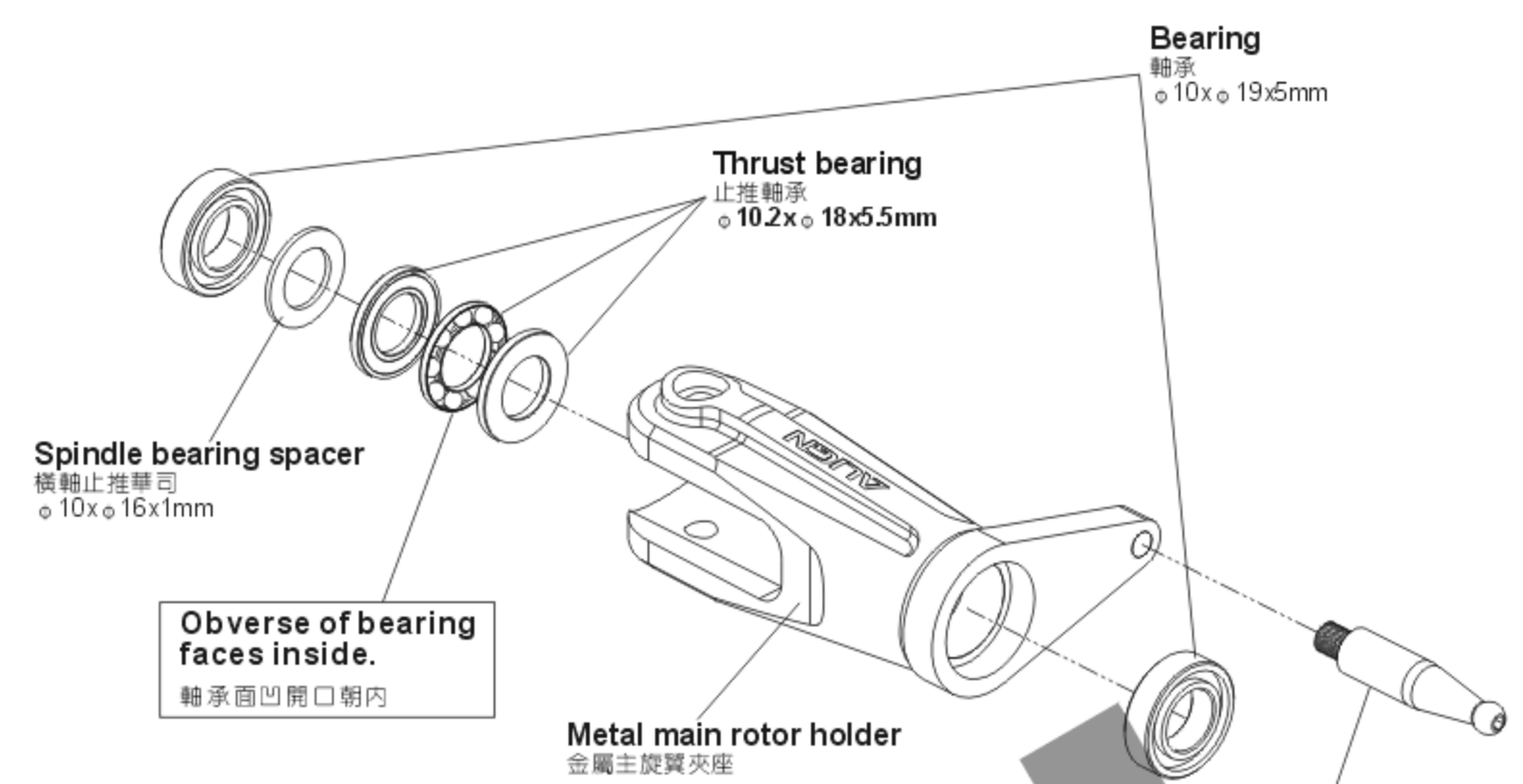

CAUTION 注意

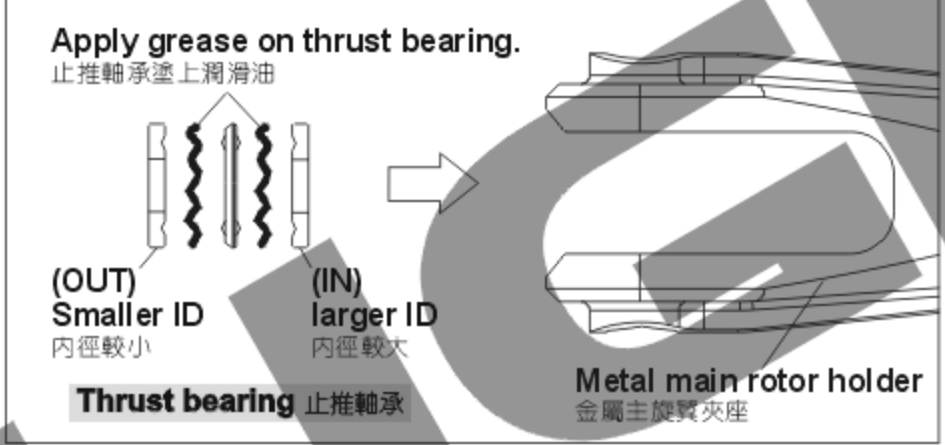

CAUTION 注意

Already assembled by Factory.  
Before flying, please check if the screws are fixed with glue.  
原裝組裝完成品，每一次飛行前請先確認螺絲是否已上膠不會鬆動。

700FLH3



ALIGN Logo on the top  
字樣朝上

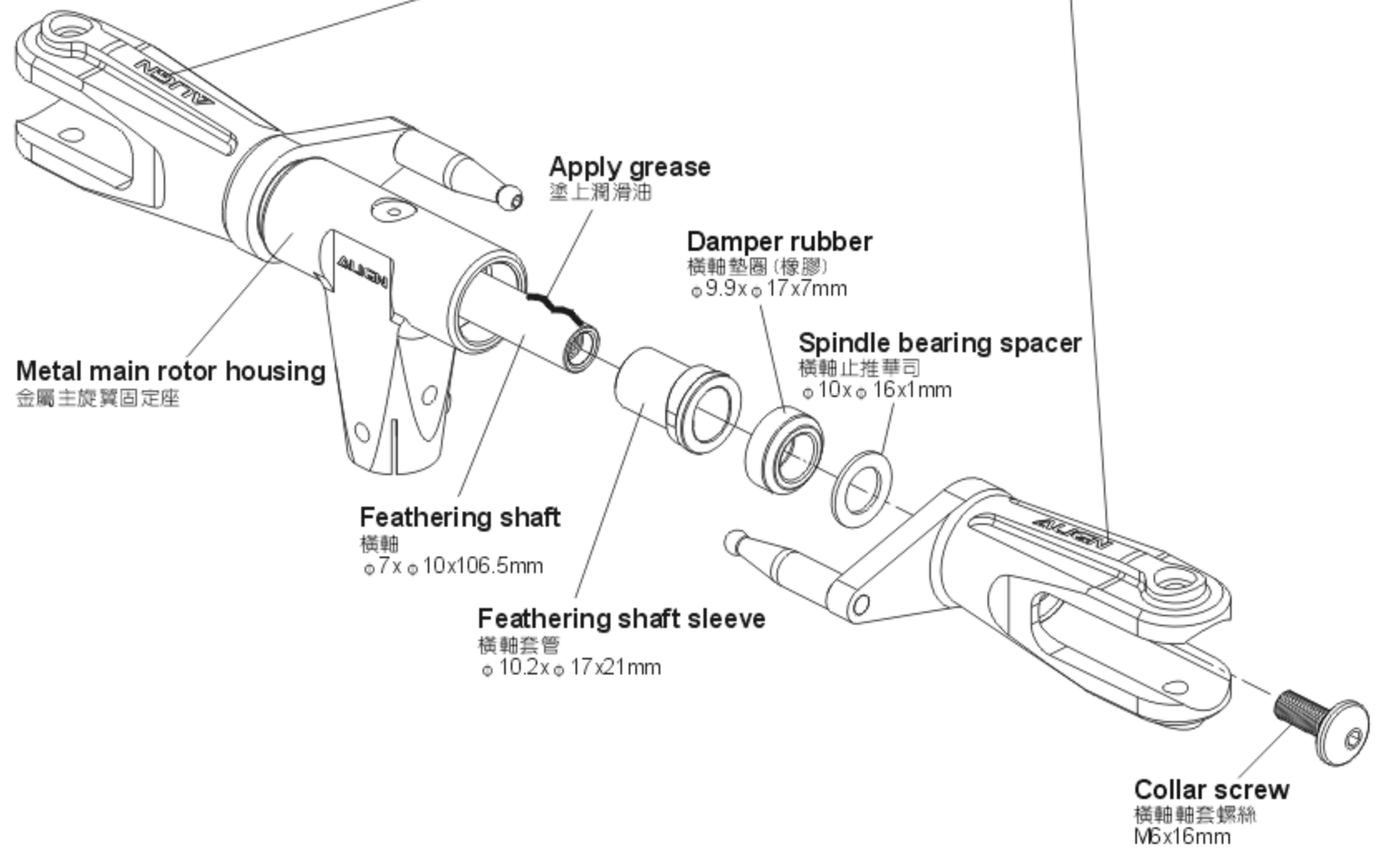

## 700FLZ4

**Linkage rod(A)**  
連桿(A)  $\phi 2.5 \times 65 \text{mm} \times 2$





## 700FLH3

-  **Bearing**  
軸承( $\phi 3 \times \phi 7 \times 3 \text{mm}$ ) x 4
-  **Bearing**  
軸承( $\phi 2 \times \phi 5 \times 2.3 \text{mm}$ ) x 4
-  **Socket screw**  
圓頭內六角螺絲(M2x5mm) x 4
-  **Socket screw**  
圓頭內六角螺絲(M3x14mm) x 1
-  **Socket screw**  
圓頭內六角螺絲(M3x20mm) x 1
-  **Washer**  
華司( $\phi 3 \times \phi 4.8 \times 0.3 \text{mm}$ ) x 2
-  **Collar**  
擺臂軸承襯套( $\phi 3 \times \phi 4.8 \times 1.5 \text{mm}$ ) x 2

 **Ball Links x4**  
(use with link rod A)  
連桿頭 x4(連桿A專用)

**Linkage rod(A)**  
Approx. 83.5mm x 2  
連桿(A)約83.5mm x 2

## 700FLH3A

-  **Linkage ball C(M3x3.5)**  
球頭C(M3x3.5)( $\phi 5 \times 8.5 \text{mm}$ ) x 2
-  **Socket screw**  
圓頭內六角螺絲(M3x10mm) x 1
-  **Socket screw**  
圓頭內六角螺絲(M4x8mm) x 2
-  **M4 Nut**  
M4防鬆螺帽 x 1
-  **Socket collar screw**  
圓頭內六角軸套螺絲(M4x24mm) x 1

## 700FLH4

 **Linkage ball B(M3x4)**  
球頭B(M3x4)( $\phi 5 \times 12 \text{mm}$ ) x 5

**CAUTION**  
注意

Already assembled by Factory. Before flying, please check if the screws are fixed with glue.  
原裝組裝完成品，每一次飛行前請先確認螺絲是否已上膠不會鬆動。

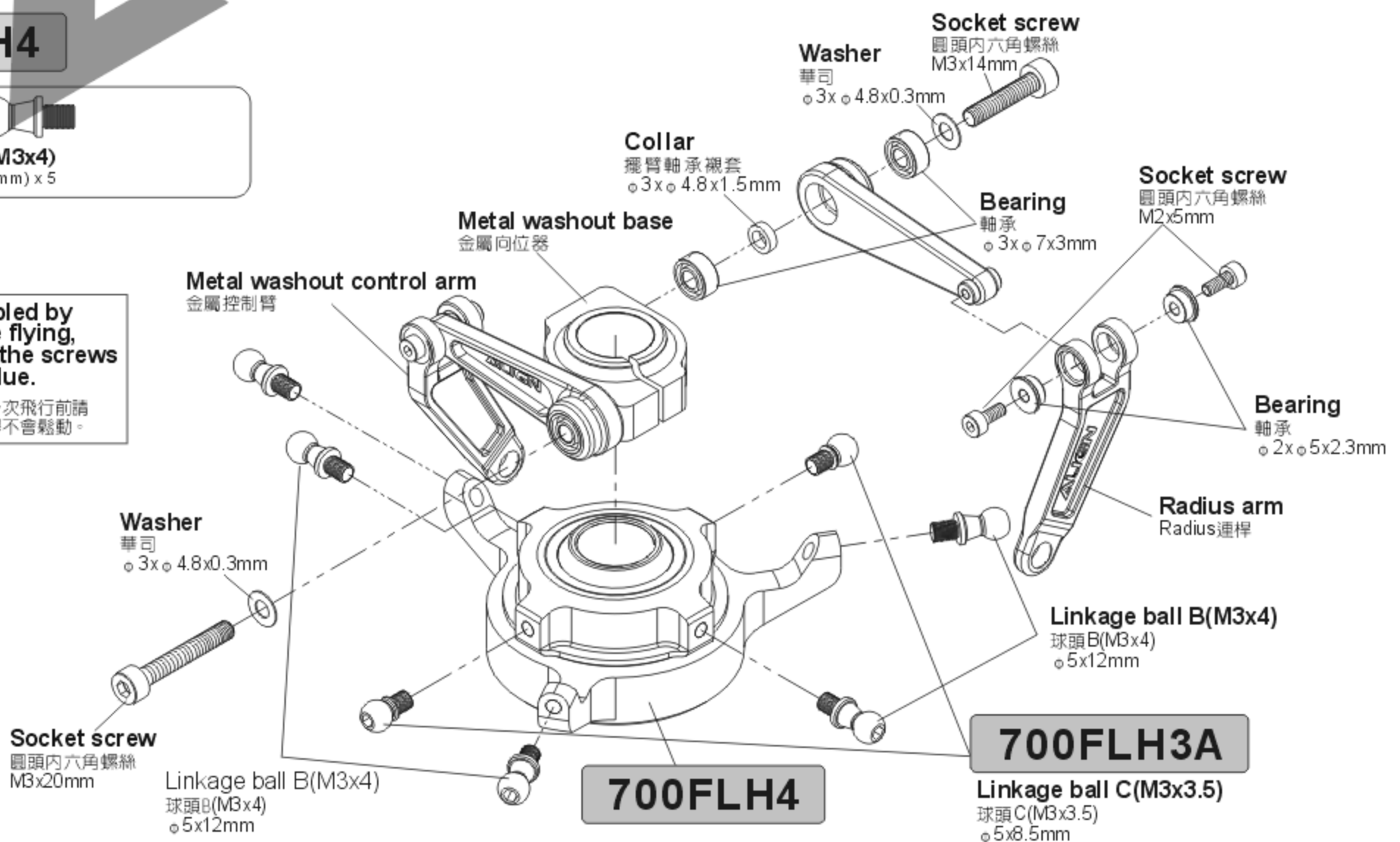

### 700HB3A



**Frame mounting block**  
機身固定塊

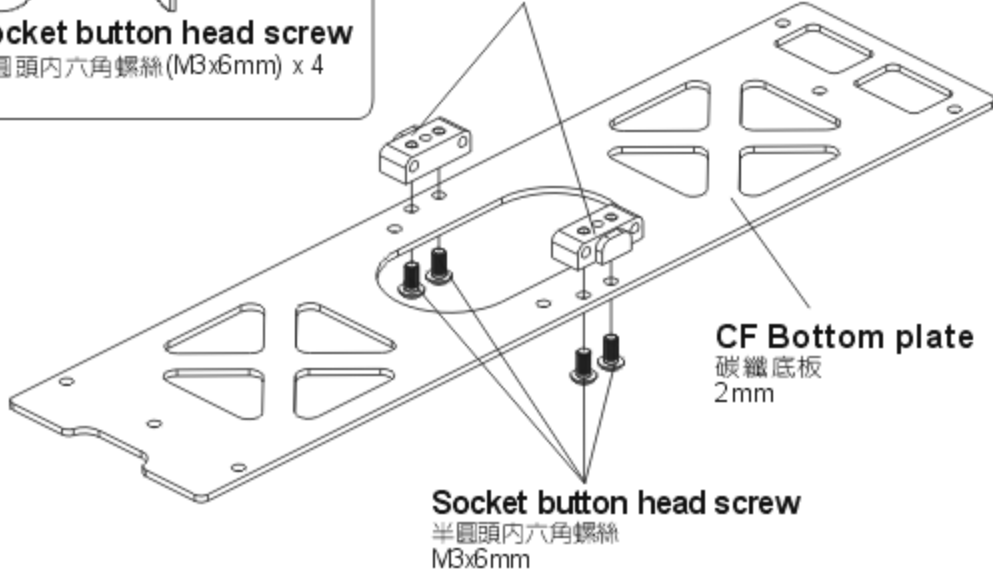

### 700HZ4



**Make sure the motor mount is fully fastener before fasten the motor pinion gear mount.**  
先將馬達固定座鎖緊固定後，再將馬達齒座鎖緊。

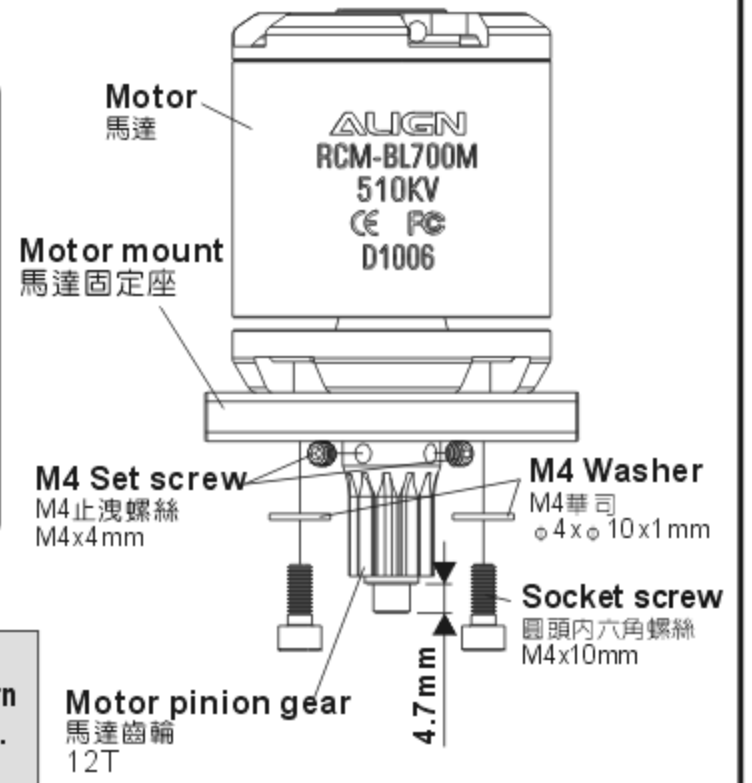

### 700HB3

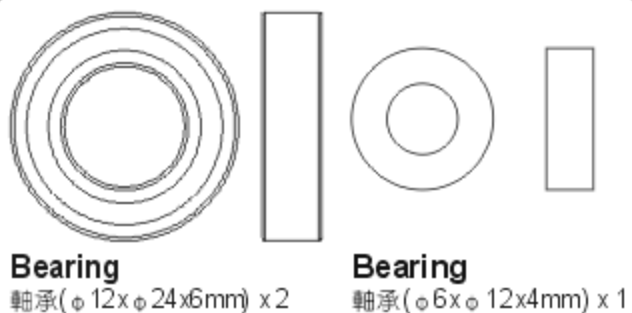

### 700HB4A



### 700HB3A

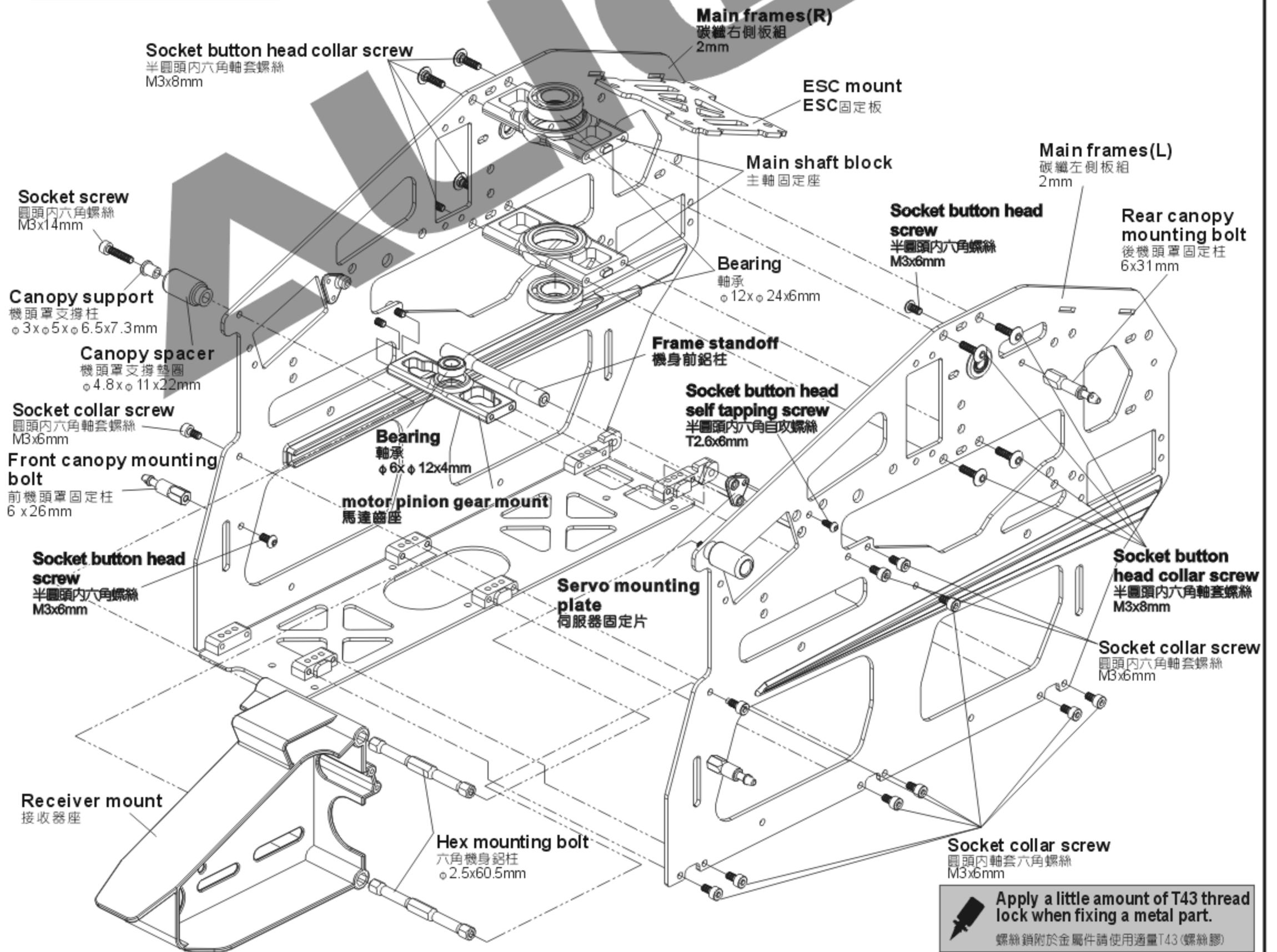

**Apply a little amount of T43 thread lock when fixing a metal part.**  
螺絲鎖附於金屬件請使用適量T43 (螺絲膠)



**Main frame assembly key point :**

**First do not fully tighten the screws of main frames and put two bearings through the main shaft to check if the movements are smooth. The bottom bracket must be firmly touched the level table top(glass surface) :** please keep the smooth movements on main shaft and level bottom bracket, then slowly tighten the screws.  
**This assembly can help for the power and flight performance.**

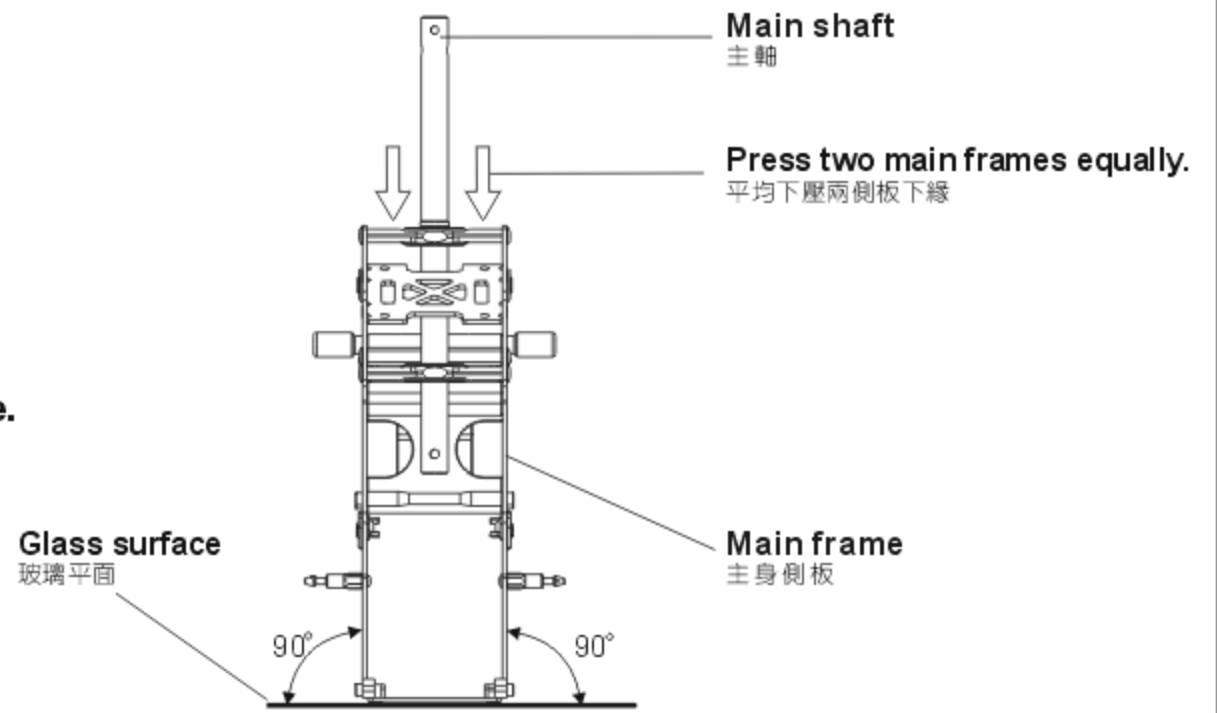

**機身側板組立重點：**

側板螺絲先不完全鎖緊，放入主軸貫穿二顆軸承確認上下移動必需滑順，主體底板必須與水平桌面（玻璃平面）踏實緊貼：請保持主軸滑順與底板平行桌面後慢慢鎖緊螺絲。正確側板的組裝對動力與飛行性能有顯著幫助。



**700HG1A**

Apply a little amount of T43 thread lock when fixing a metal part.  
 螺絲鎖附於金屬件請使用適量T43(螺絲膠)

-  **Socket screw**  
圓頭內六角螺絲(M3x10mm) x 4
-  **M3 Washer**  
M3華司(φ3xφ8x1mm) x 4
-  **M3 Set screw**  
M3止洩螺絲(M3x4mm) x 4

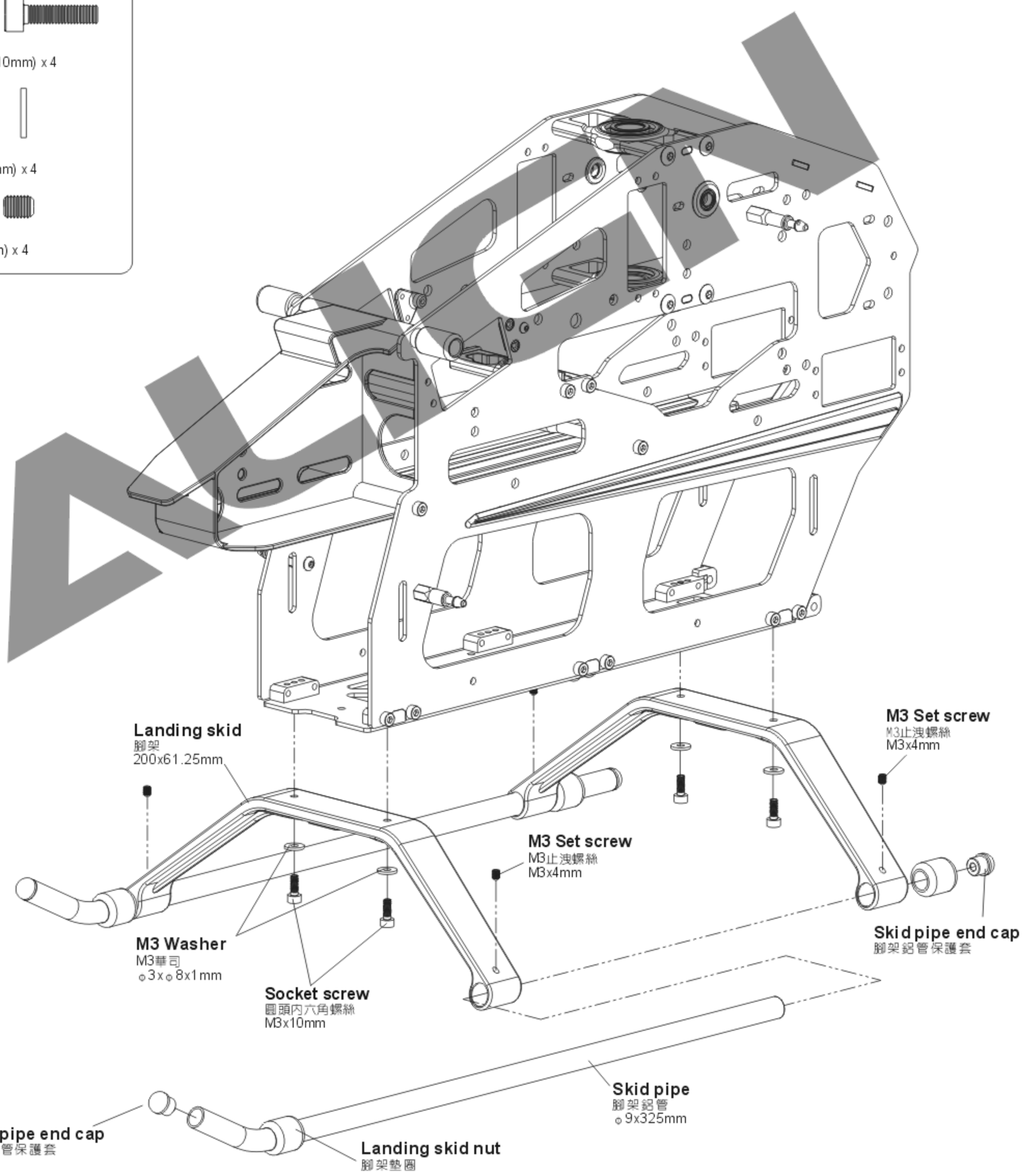

# 700HZ5

Apply a little amount of T43 thread lock when fixing a metal part.  
 螺絲鎖附於金屬件請使用適量T43(螺絲膠)

- Linkage ball C(M2x4)**  
球頭C(M2x4)( $\phi$  5x9mm) x 4
- Socket button head self tapping screw**  
半圓頭內六角自攻螺絲(T2.6x12mm) x 12
- M2 Nut**  
M2螺帽 x 4

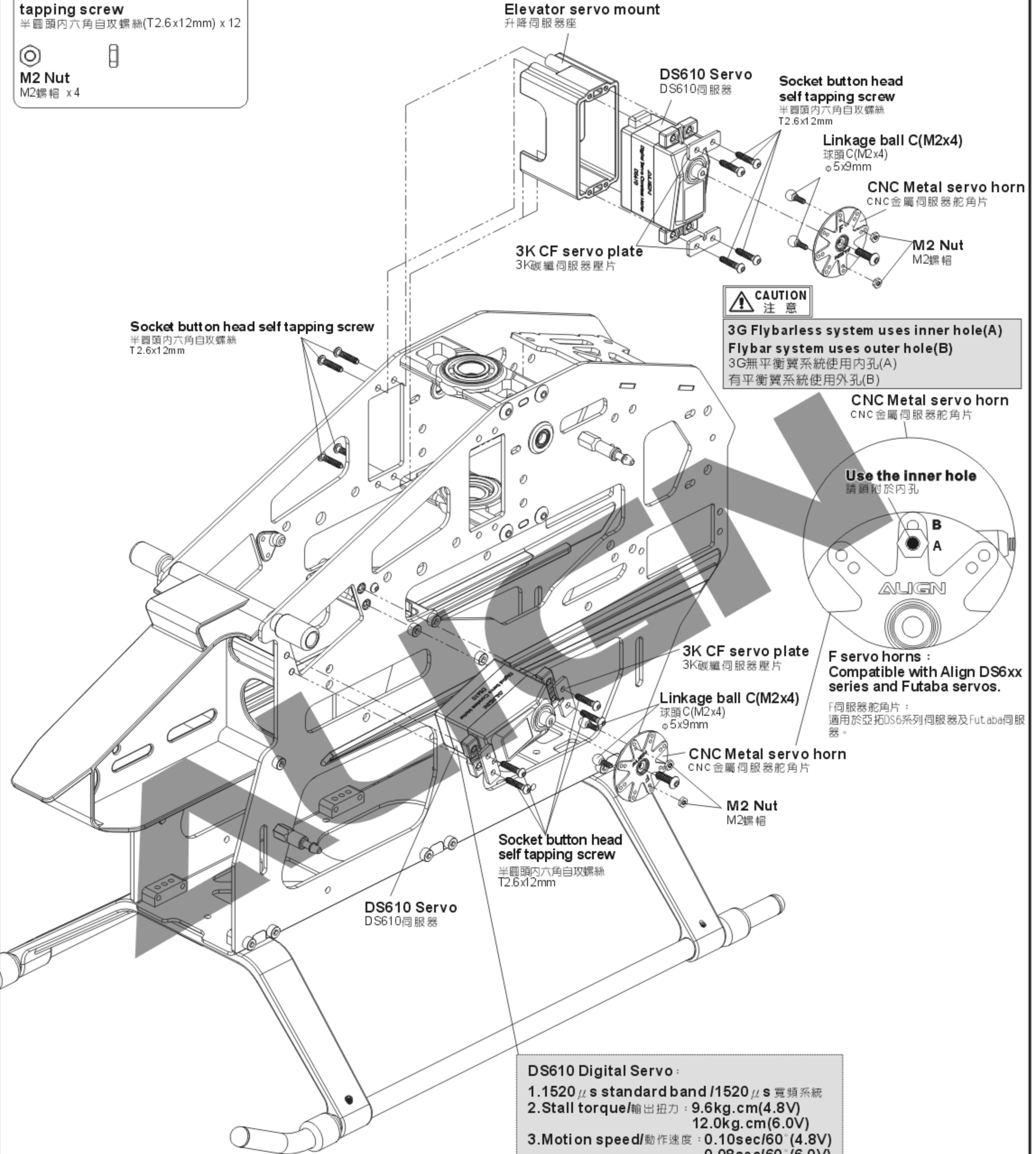

**CAUTION 注意**  
 3G Flybarless system uses inner hole(A)  
 Flybar system uses outer hole(B)  
 3G無平衡簧系統使用內孔(A)  
 有平衡簧系統使用外孔(B)

**CNC Metal servo horn**  
 CNC金屬伺服器舵角片

**Use the inner hole**  
 請鎖附於內孔

**F servo horns :**  
 Compatible with Align DS6xx series and Futaba servos.  
 F伺服器舵角片：  
 適用於亞拓DS6系列伺服器及Futaba伺服器。

**DS610 Digital Servo :**

- 1.1520  $\mu$ s standard band / 1520  $\mu$ s 寬頻系統
2. Stall torque / 輸出扭力 : 9.6kg.cm(4.8V)  
12.0kg.cm(6.0V)
3. Motion speed / 動作速度 : 0.10sec/60° (4.8V)  
0.08sec/60° (6.0V)
4. Dimension / 尺寸 : 40.3 x 20.1 x 36mm
5. Weight / 重量 : 52.2g

# 700HZ5

- Linkage ball C (M2x4)**  
球頭C (M2x4) (φ5x9mm) x 3
- Socket button head self tapping screw**  
半圓頭內六角自攻螺絲 (T2.6x12mm) x 12
- M2 Nut**  
M2螺帽 x 3

# 700HB3A

- Socket button head collar screw**  
半圓頭內六角軸套螺絲 (M3x8mm) x 4

Recommend sanding the marked position as below illustration with a waterproof abrasive paper (#800-1000) to avoid the wires of electric parts to be cut.

建議於下圖色塊標示處，使用#800-1000水砂紙打磨，可防止電子設備電線被割破。

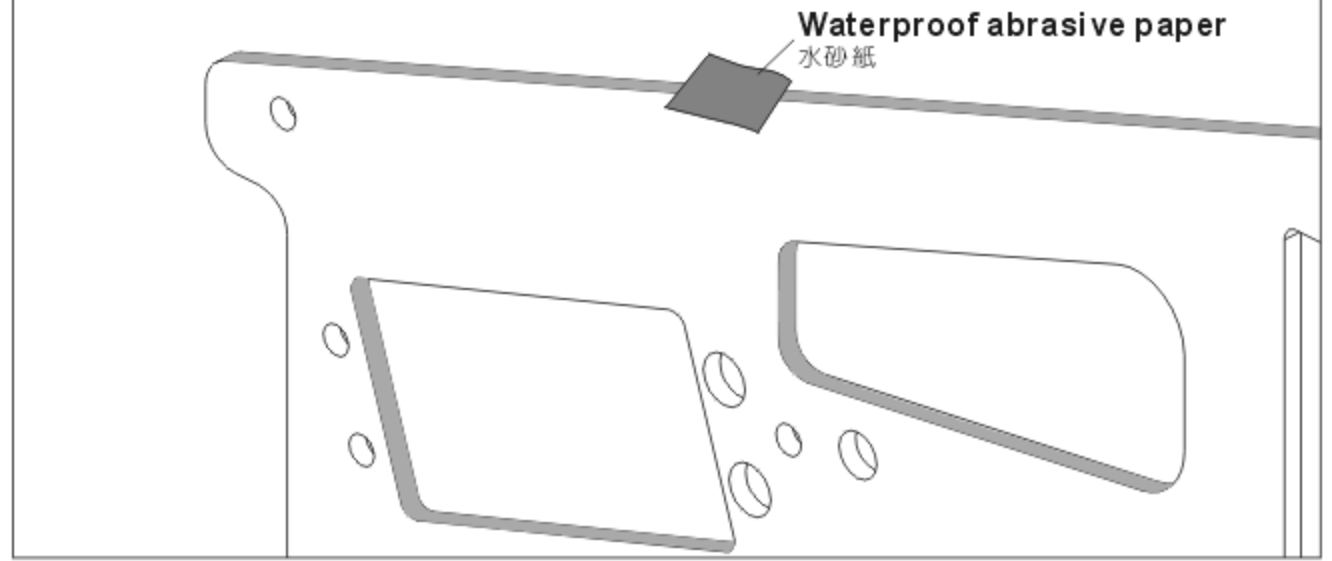

- DS610 Digital Servo :**
1. 1520 μs standard band / 1520 μs 寬頻系統
  2. Stall torque/輸出扭力 : 9.6kg.cm (4.8V)  
12.0kg.cm (6.0V)
  3. Motion speed/動作速度 : 0.10sec/60° (4.8V)  
0.08sec/60° (6.0V)
  4. Dimension/尺寸 : 40.3 x 20.1 x 36mm
  5. Weight/重量 : 52.2g

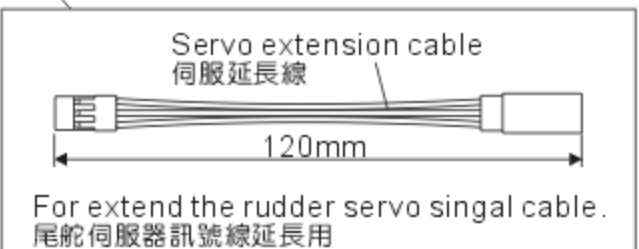
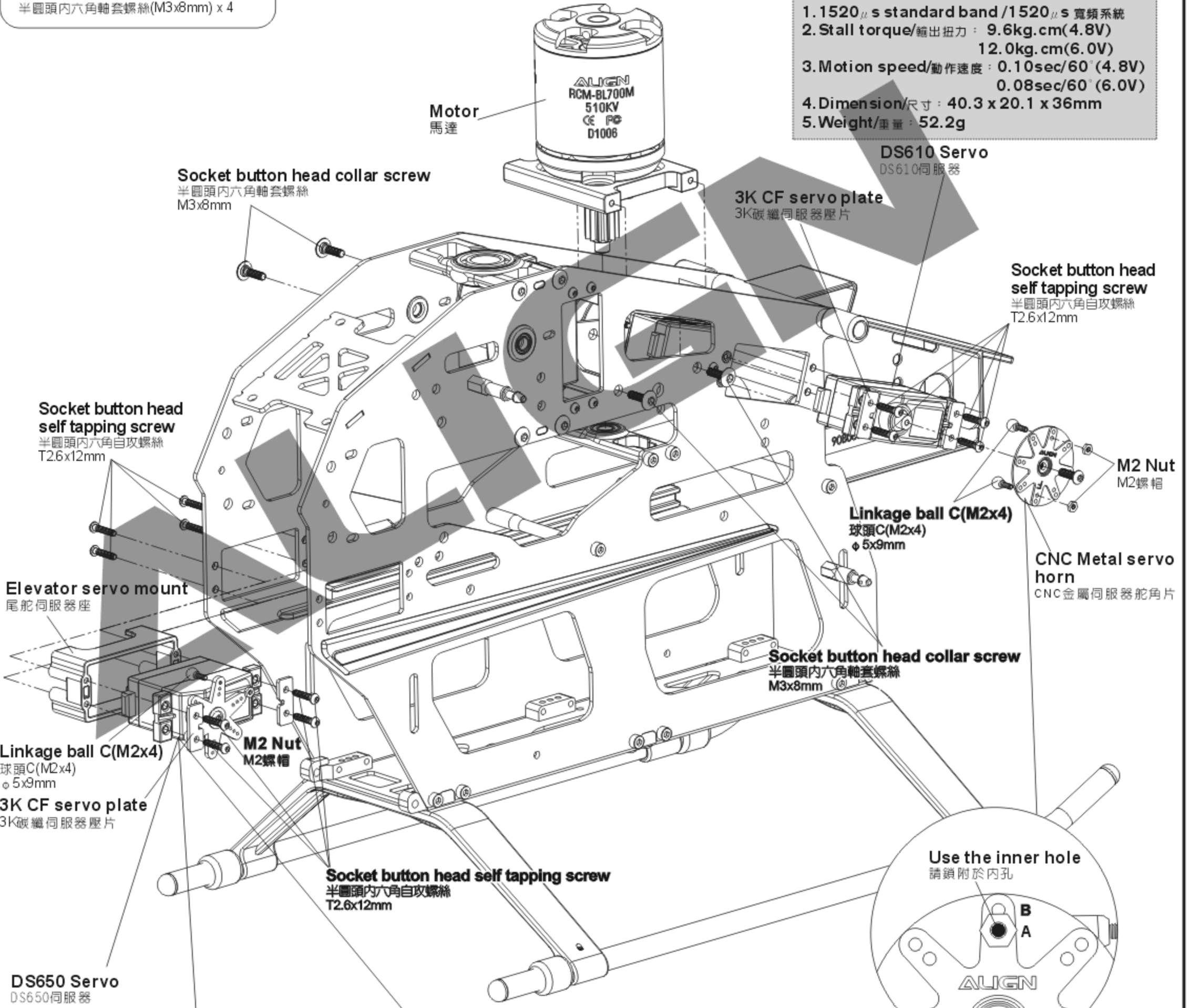

### 700HB3

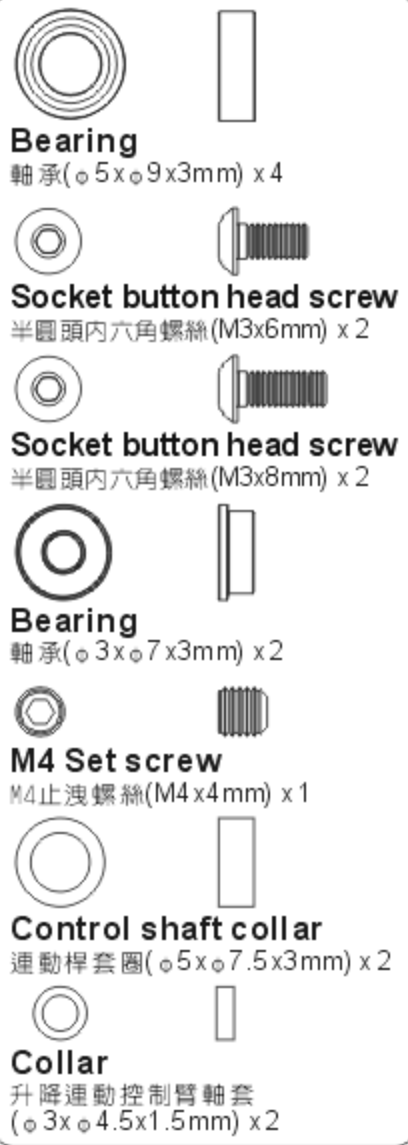

### 700HB3A

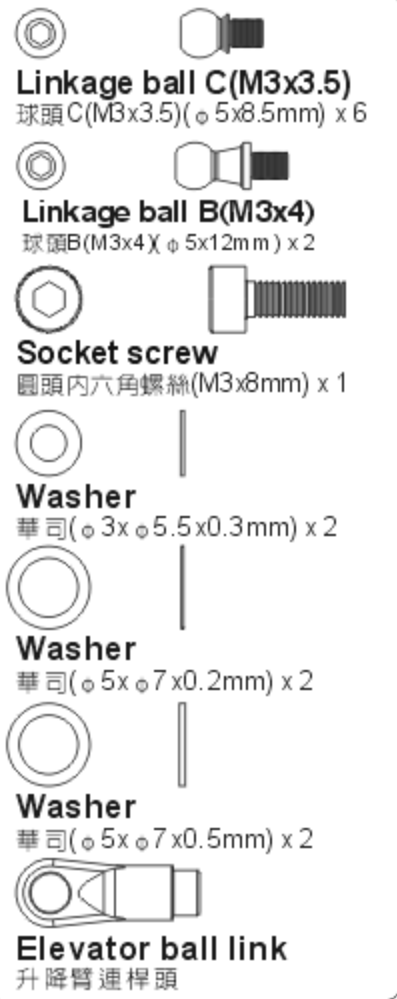

### 700FLZ4



**3G Flybarless system uses inner hole(A)**  
**Flybar system uses outer hole(B)**  
3G無平衡翼系統使用內孔(A)  
有平衡翼系統使用外孔(B)

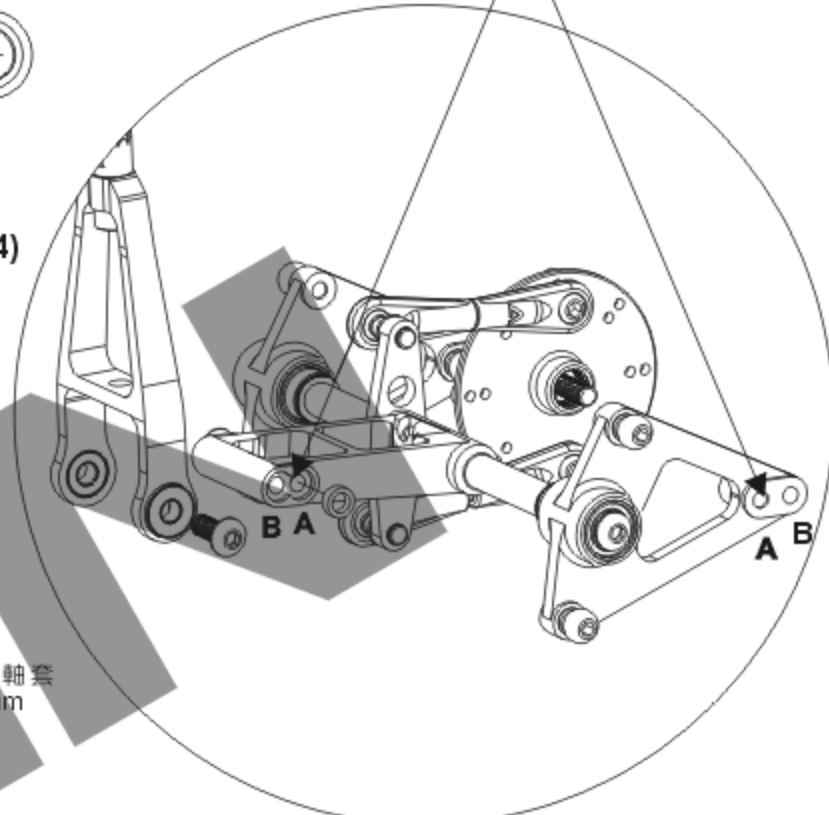
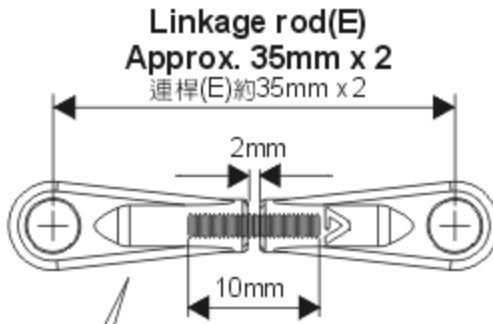

**Linkage ball B(M3x4)**  
球頭B(M3x4)  
φ5x12mm

**M4 Set screw**  
M4止洩螺絲  
M4x4mm

**Elevator lever**  
升降運動控制臂

**Collar**  
升降運動控制臂軸套  
φ3xφ4.5x1.5mm

**Elevator ball link**  
升降臂連桿頭

**Elevator arm**  
升降控制臂

**Socket screw**  
圓頭內六角螺絲  
M3x8mm

**Bearing**  
軸承  
φ3xφ7x3mm

**Socket button head screw**  
半圓頭內六角螺絲  
M3x8mm

**Linkage ball C(M3x3.5)**  
球頭C(M3x3.5)  
φ5x8.5mm

**Control shaft collar**  
運動桿套圈  
φ5xφ7.5x3mm

**Washer spare for gap adjustment.**  
間隙調整用華司

**Washer**  
華司  
φ5xφ7x0.2mm

**Washer**  
華司  
φ5xφ7x0.5mm

**Linkage ball C(M3x3.5)**  
球頭C(M3x3.5)  
φ5x8.5mm

**Aileron lever**  
左右控制搖臂

**Socket button head screw**  
半圓頭內六角螺絲  
M3x8mm

**Bearing**  
軸承  
φ5xφ9x3mm

**Washer**  
華司  
φ3xφ5.5x0.3mm

**Control shaft collar**  
運動桿套圈  
φ5xφ7.5x3mm

**Control shaft**  
運動桿  
φ4.7xφ5x98mm

**Linkage rod(F)**  
Approx. 130.5mm x 4  
連桿(F)約130.5mm x 4



**Socket button head screw**  
半圓頭內六角螺絲  
M3x6mm

**Washer**  
華司  
φ3xφ5.5x0.3mm

**Washer**  
華司  
φ5xφ7x0.5mm

**Washer**  
華司  
φ5xφ7x0.2mm

**Washer spare for gap adjustment.**  
間隙調整用華司

**Apply a little amount of T43 thread lock when fixing a metal part.**  
螺絲鎖附於金屬件請使用適量T43(螺絲膠)

# 700HT1

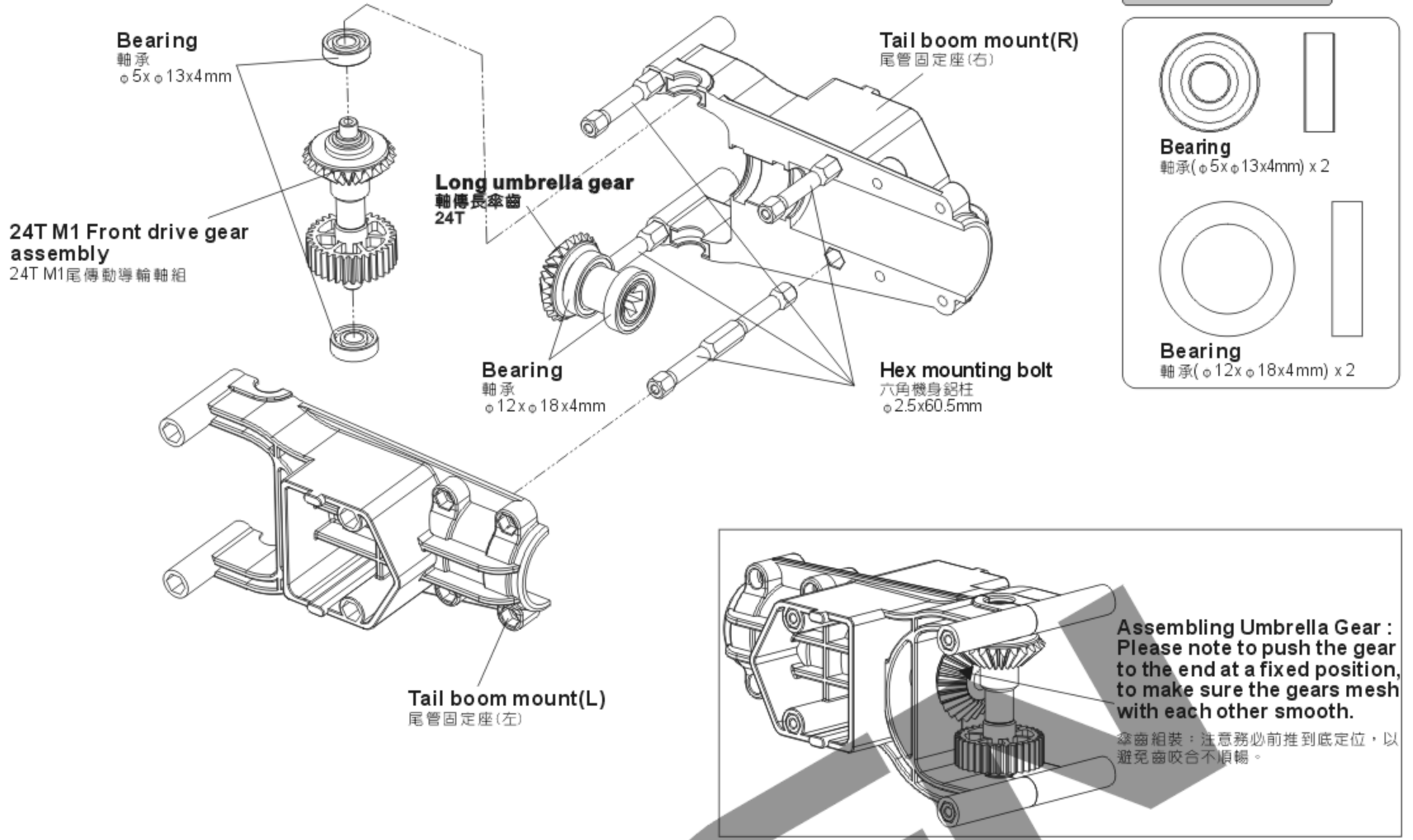

# 700NT2A

Apply a little amount of T43 thread lock when fixing a metal part.  
螺絲鎖附於金屬件請使用適量T43(螺絲膠)

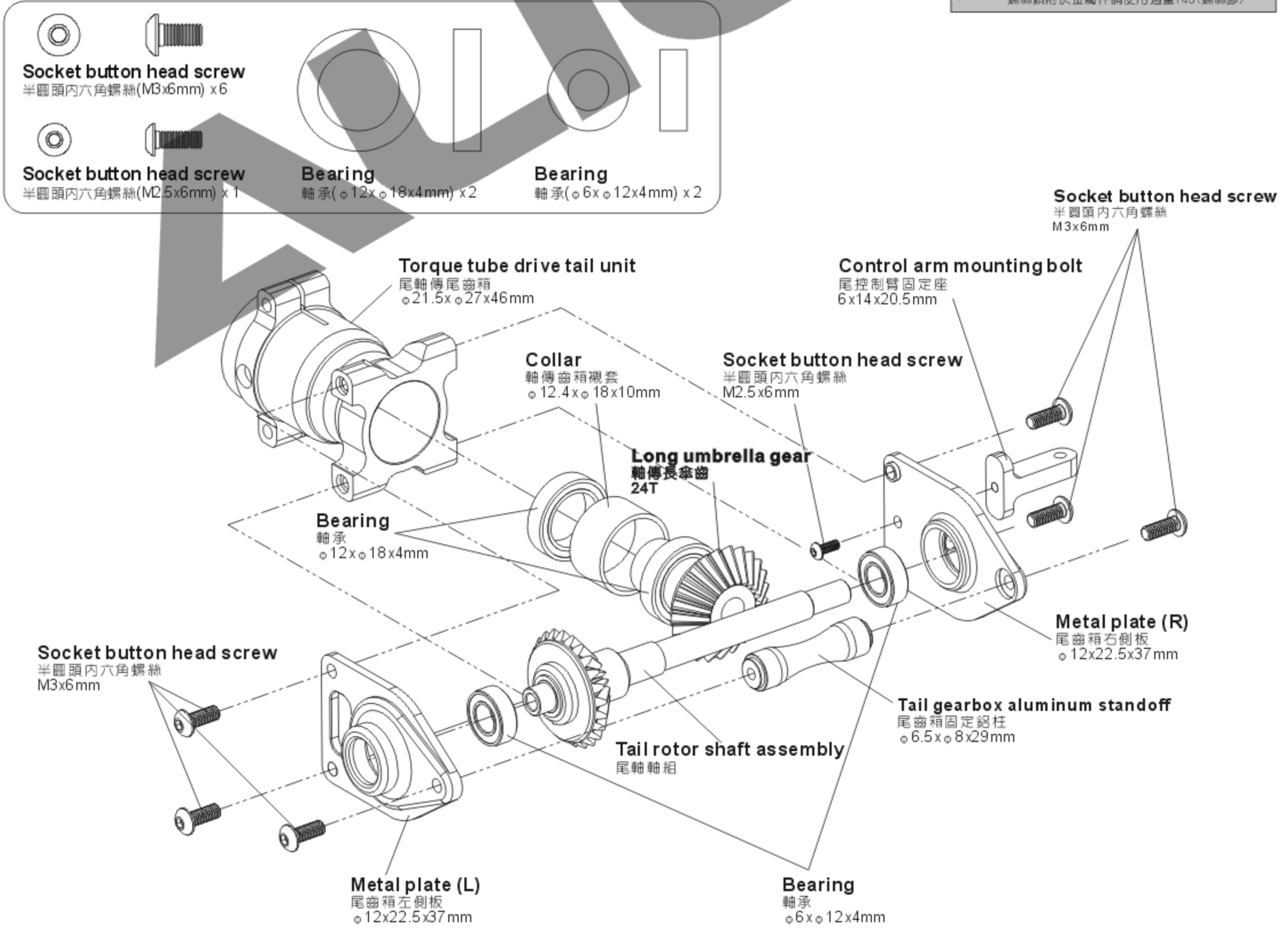

### 700NT2F

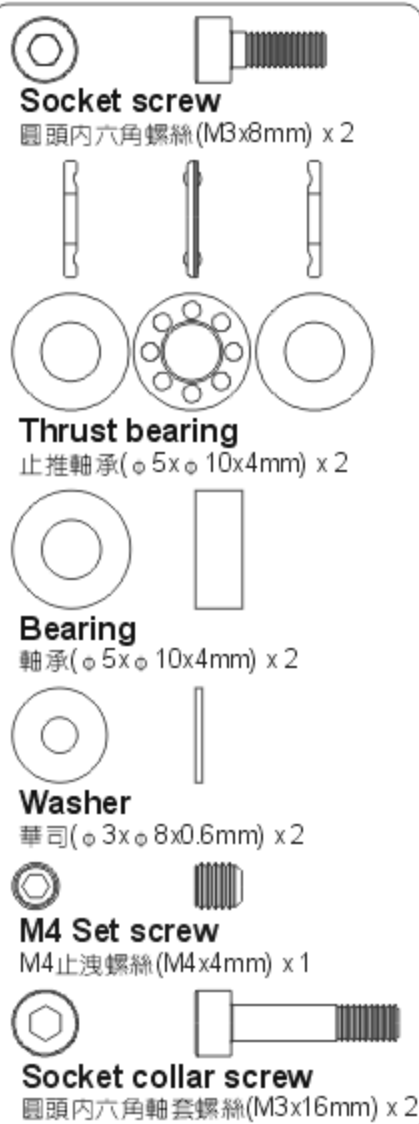

### 700NT2C



### 700NT2D



Apply a little amount of T43 thread lock when fixing a metal part.  
螺絲鎖附於金屬件請使用適量T43 (螺絲膠)



**CAUTION 注意**  
Aim tail rotor hub at the concave of tail rotor shaft and fix it, please apply a little glue on the set screw.  
尾旋翼T型座對準尾橫軸的凹刻並鎖上，請確認止洩螺絲上膠。

**Assembling Umbrella Gear : Please note to push the gear to the end at a fixed position, to make sure the gears mesh with each other smooth.**  
傘齒組裝：注意務必前推到定位，以避免齒啮合不順暢。

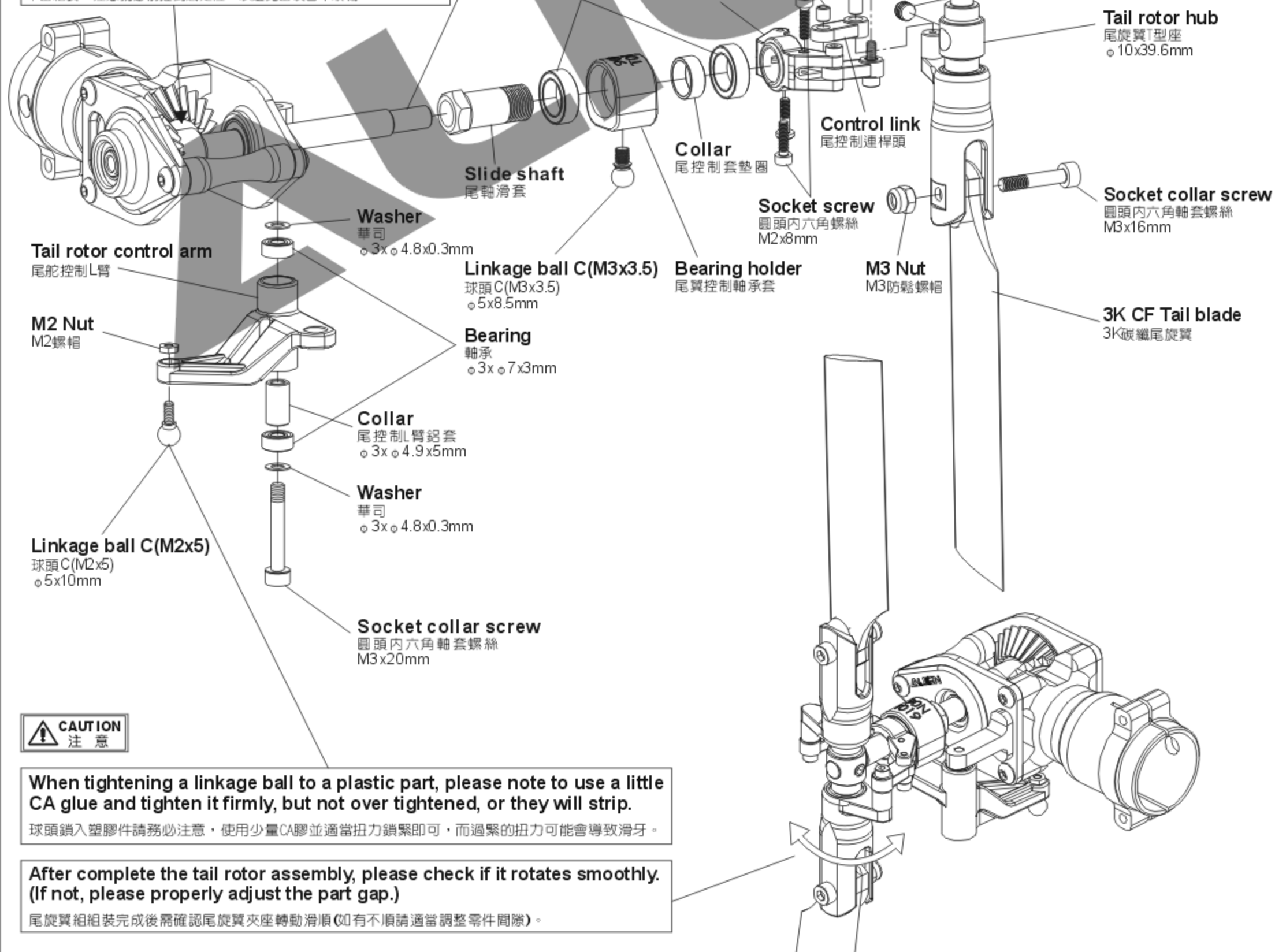

Already assembled by factory, please note to check again.  
已組裝完成，請務必自行再確認。

When assembling into the tail boom, please apply some oil on the surface, to make it smooth during the assembling and keep it vertical with the torque tube for smooth rotation.  
插入尾管內時，外表抹些潤滑油，以確保平順壓入尾管中並與尾傳動軸保持垂直，讓尾軸傳動順暢。

When assembling the tail boom, please aim at the fixing hole  $\phi 5$ .  
裝入尾管時請注意孔對準尾管  $\phi 5$  固定孔。

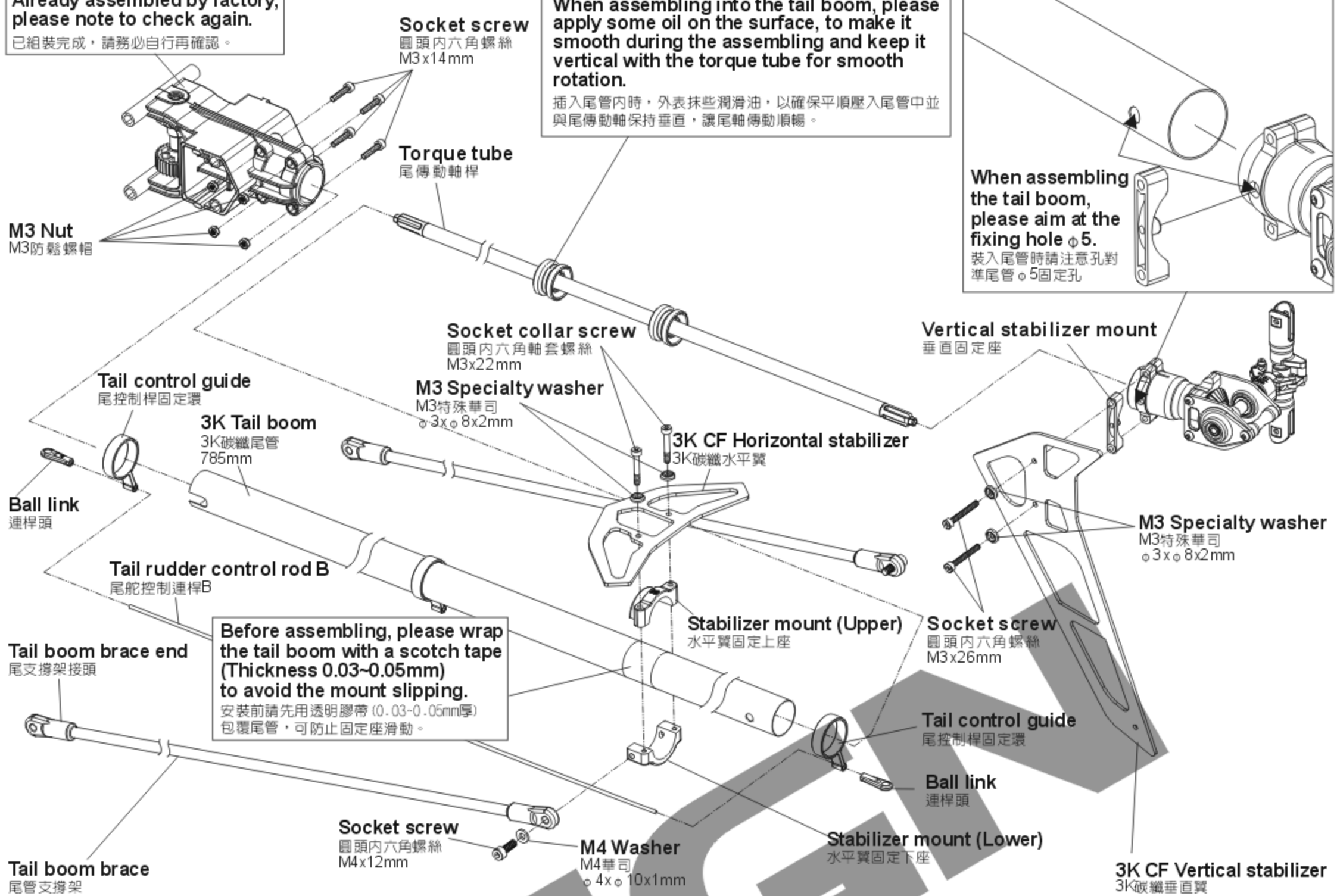

### 700NT1A

- Socket screw**  
圓頭內六角螺絲 (M3x14mm) x 4
- M3 Nut**  
M3防鬆螺帽 x 4

### 700NT2A

- Socket screw**  
圓頭內六角螺絲 (M3x26mm) x 2
- M3 Specialty washer**  
M3特殊華司 ( $\phi 3 \times \phi 8 \times 2\text{mm}$ ) x 2

### 700NT2EA

- Socket screw**  
圓頭內六角螺絲 (M4x12mm) x 2
- Socket collar screw**  
圓頭內六角軸套螺絲 (M3x22mm) x 2
- M3 Specialty washer**  
M3特殊華司 ( $\phi 3 \times \phi 8 \times 2\text{mm}$ ) x 2
- M4 Washer**  
M4華司 ( $\phi 4 \times \phi 10 \times 1\text{mm}$ ) x 2

### Tip for torque tube installation 傳動軸軸承固定位要領

Please apply some CA glue to fix bearing on the torque tube, avoid CA glue adhering to the dust cover or it may cause the bearing stuck. When assembling into the tail boom, please apply some oil on the bearing holder and press the holder into the tail boom horizontally.  
請以少量CA將軸承固定於尾傳動軸上，避免CA沾到軸承的防塵蓋而導致軸承卡死。插入尾管內時，尾傳動軸承墊圈外表抹些潤滑油，將尾傳動軸承墊圈平行壓入尾管中不可歪斜。

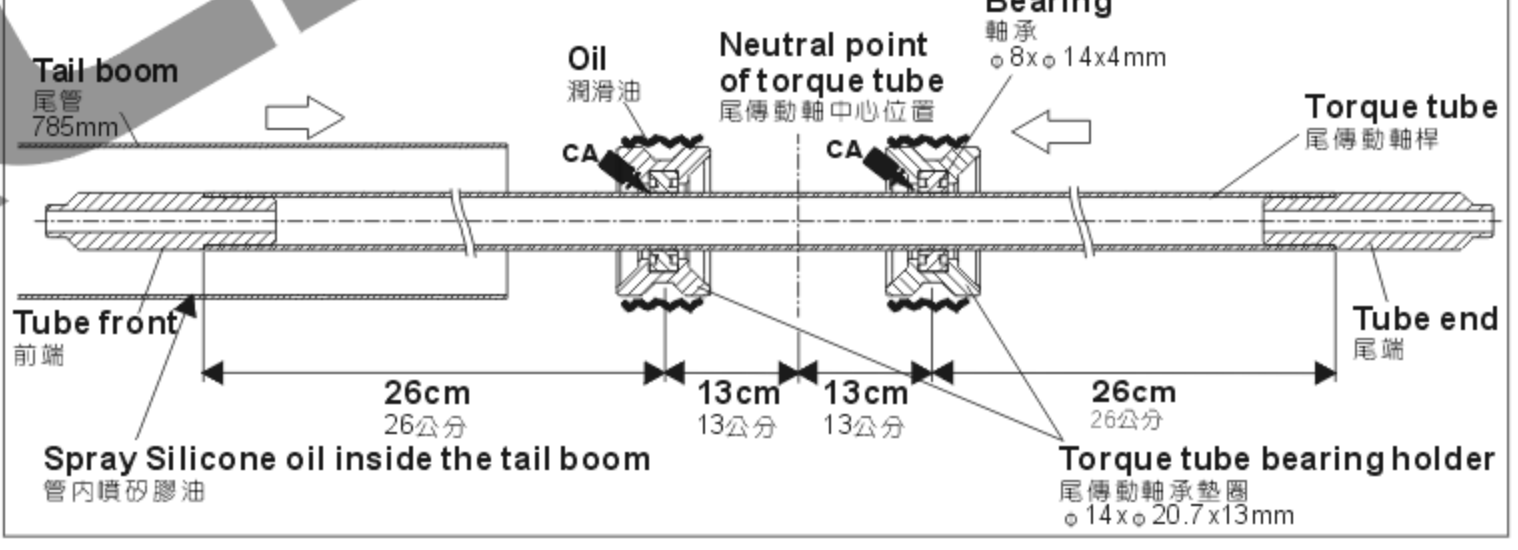

### 700NT3BA

- Ball link**  
連桿頭 x 2

Apply a little amount of T43 thread lock when fixing a metal part.  
螺絲鎖附於金屬件請使用適量T43(螺絲膠)

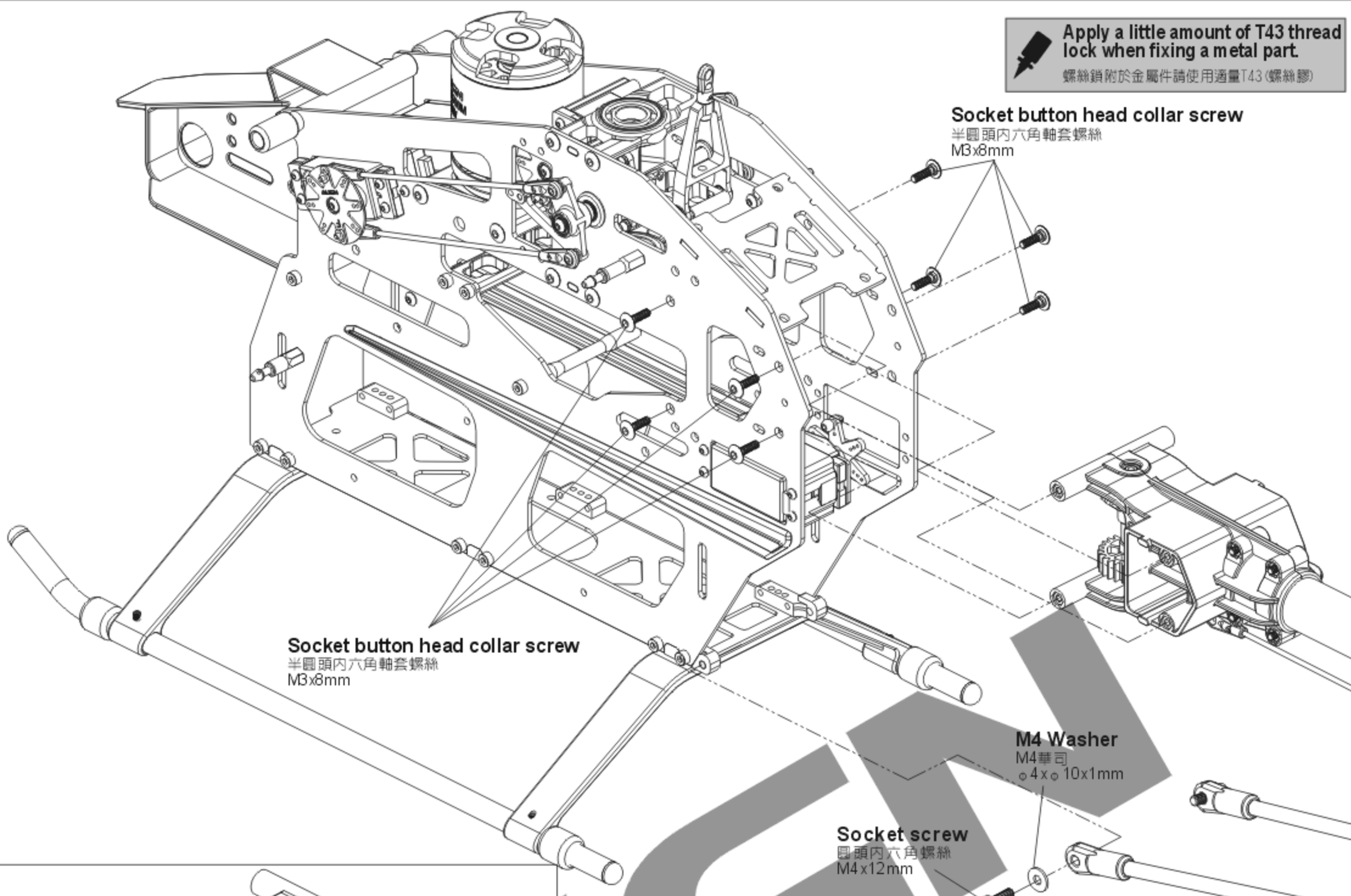

**Socket button head collar screw**  
半圓頭內六角軸套螺絲  
M3x8mm

**Socket button head collar screw**  
半圓頭內六角軸套螺絲  
M3x8mm

**M4 Washer**  
M4華司  
φ4xφ10x1mm

**Socket screw**  
圓頭內六角螺絲  
M4x12mm

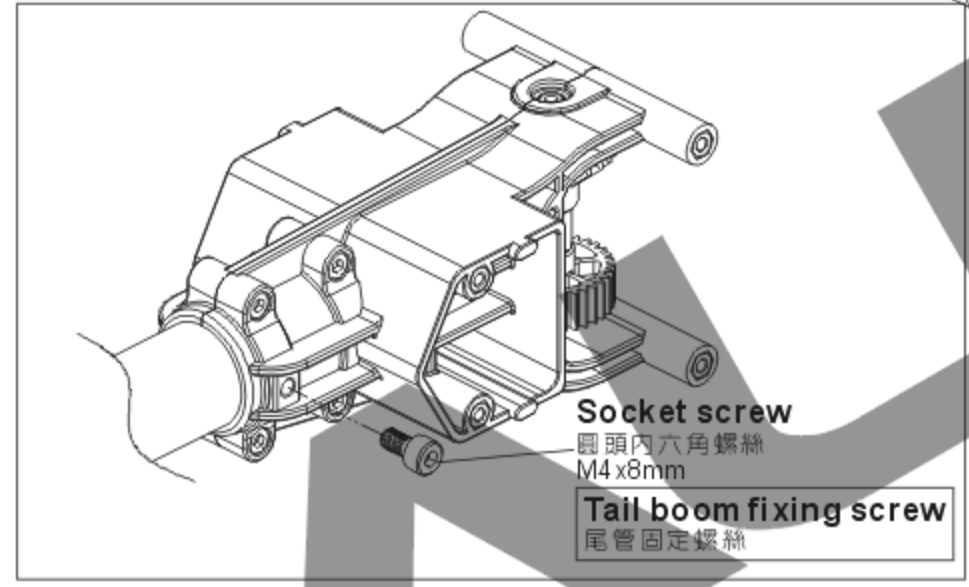

**Socket screw**  
圓頭內六角螺絲  
M4x8mm  
**Tail boom fixing screw**  
尾管固定螺絲

**700HB3A**

- Socket screw**  
圓頭內六角螺絲(M4x12mm) x 2
- M4 Washer**  
M4華司(φ4xφ10x1mm) x 2

**700NT1A**

- Socket button head collar screw**  
半圓頭內六角軸套螺絲(M3x8mm) x 8
- Socket screw**  
圓頭內六角螺絲(M4x8mm) x 1

**700HB5**

- Bearing**  
軸承(φ15xφ21x4mm) x 2
- One-way bearing**  
單向軸承(φ15xφ23x11mm) x 1
- Socket screw**  
圓頭內六角螺絲(M2.5x8mm) x 6
- Socket button head screw**  
半圓頭內六角螺絲(M3x6mm) x 6

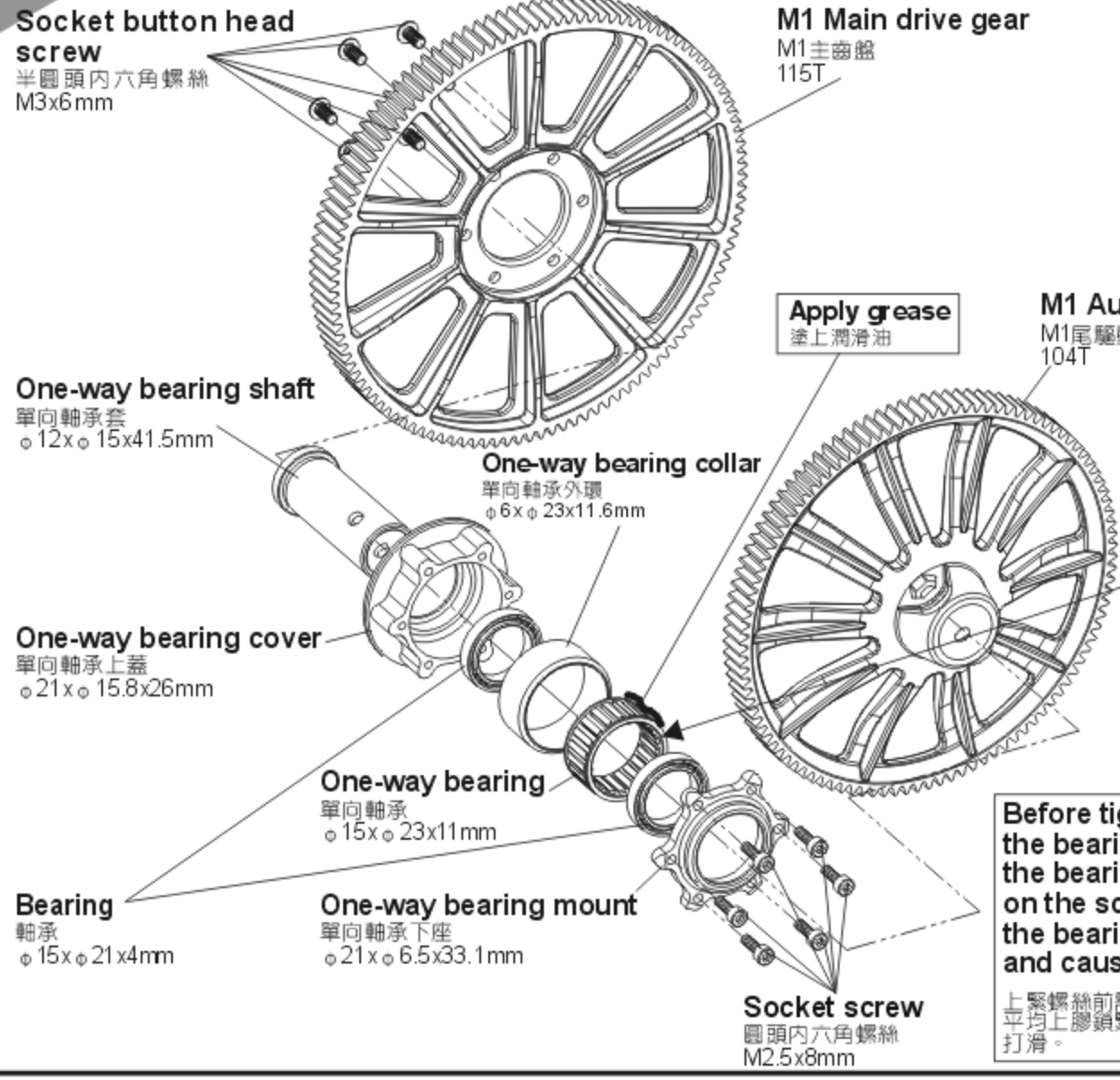

**Socket button head screw**  
半圓頭內六角螺絲  
M3x6mm

**M1 Main drive gear**  
M1主齒盤  
115T

**One-way bearing shaft**  
單向軸承套  
φ12xφ15x41.5mm

**One-way bearing collar**  
單向軸承外環  
φ6xφ23x11.6mm

**One-way bearing cover**  
單向軸承上蓋  
φ21xφ15.8x26mm

**One-way bearing**  
單向軸承  
φ15xφ23x11mm

**Bearing**  
軸承  
φ15xφ21x4mm

**One-way bearing mount**  
單向軸承下座  
φ21xφ6.5x33.1mm

**Socket screw**  
圓頭內六角螺絲  
M2.5x8mm

**Apply grease**  
塗上潤滑油

**M1 Autorotation tail drive gear**  
M1尾驅動主齒  
104T

**CAUTION**  
注意

Already assembled by Factory. Before flying, please check if the screws are fixed with glue.  
原裝組裝完成品，每一次飛行前請先確認螺絲是否已上膠不會鬆動。

Please note the direction of bearing.  
請注意軸承方向

Before tightening the screw, please rotate the bearing and check the concentricity of the bearing. Then apply some glue evenly on the screw and tighten it firmly, to avoid the bearing stuck or heavy load at one side and cause slip.

上緊螺絲前請試轉動確認軸承同心度良好後，才能將螺絲平均上膠鎖緊，以避免造成卡死或單向重負載可能產生的打滑。



Apply a little amount of T43 thread lock when fixing a metal part.  
 螺絲鎖附於金屬件請使用適量T43(螺絲膠)

When tightening the main blade fixing screw, please tighten it firmly, but not over tighten, or it may cause the damage of main blade holder and result in danger.  
 鎖緊主旋翼螺絲須注意適當緊度即可，過緊可能導致主旋翼夾座受損，飛行意外發生。

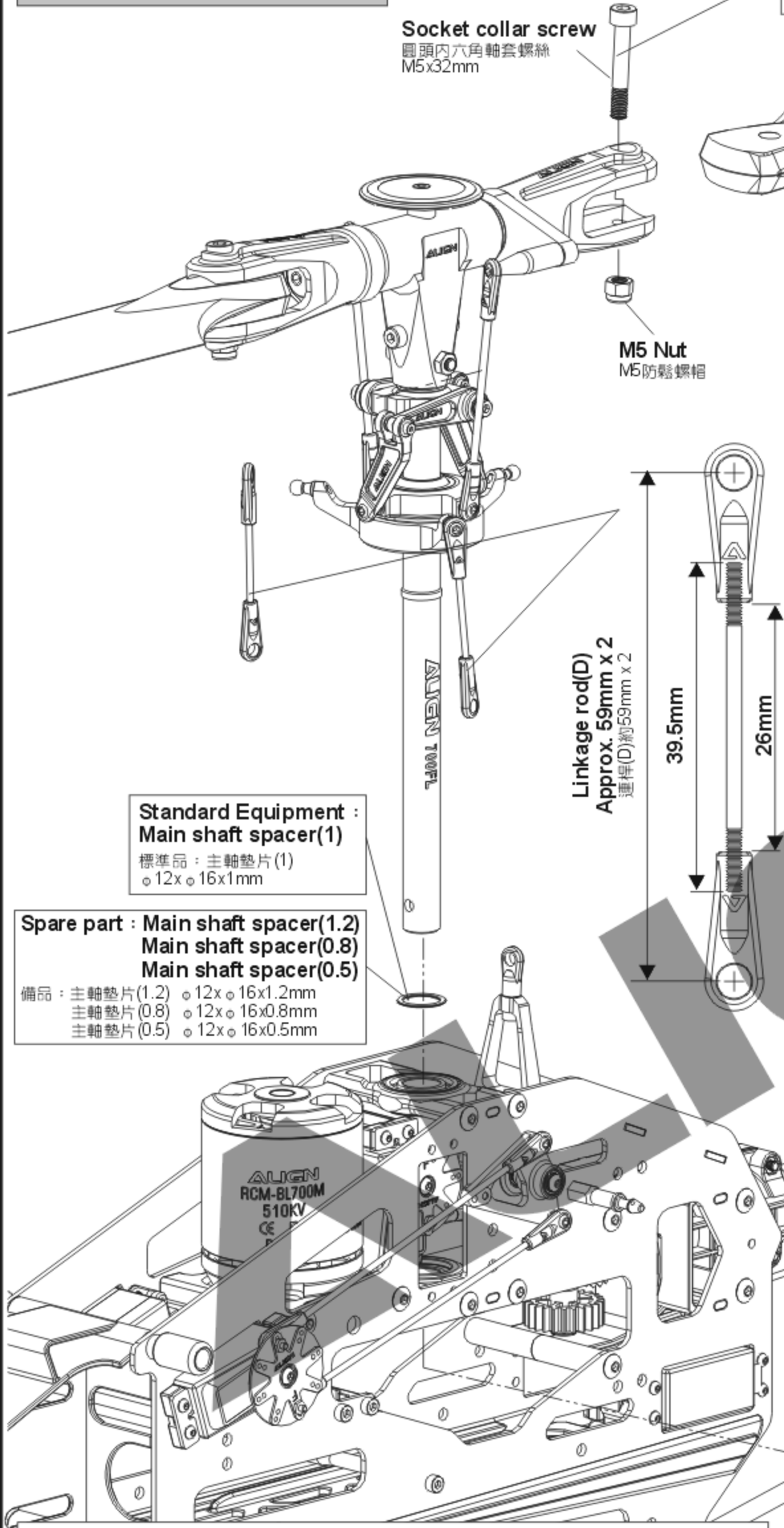

**700HB5**

- Socket collar screw (圓頭內六角軸套螺絲 (M4x27mm) x 1)
- M4 Nut (M4防鬆螺帽 x 1)

**700FLH4**

- Main shaft spacer(1) (主軸墊片(1) (12x16x1mm) x 1)
- Spare part: Main shaft spacer(0.8) (備品: 主軸墊片(0.8) (12x16x0.8mm) x 1)
- Spare part: Main shaft spacer(1.2) (備品: 主軸墊片(1.2) (12x16x1.2mm) x 1)
- Spare part: Main shaft spacer(0.5) (備品: 主軸墊片(0.5) (12x16x0.5mm) x 1)

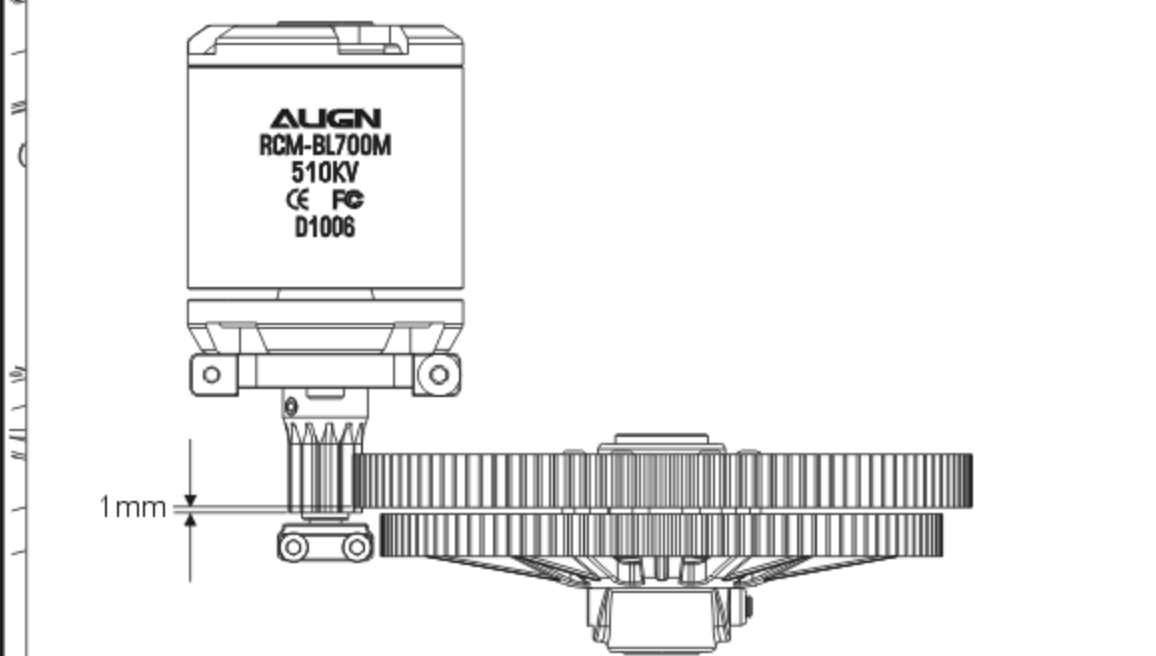

After assembling the motor pinion gear and main drive gear, the horizontal distance must be within 1mm and keep the gear mesh at a proper distance.  
 馬達齒輪與主齒盤組立後平行距離不可超過1mm，並保持兩齒咬合有適當間距。

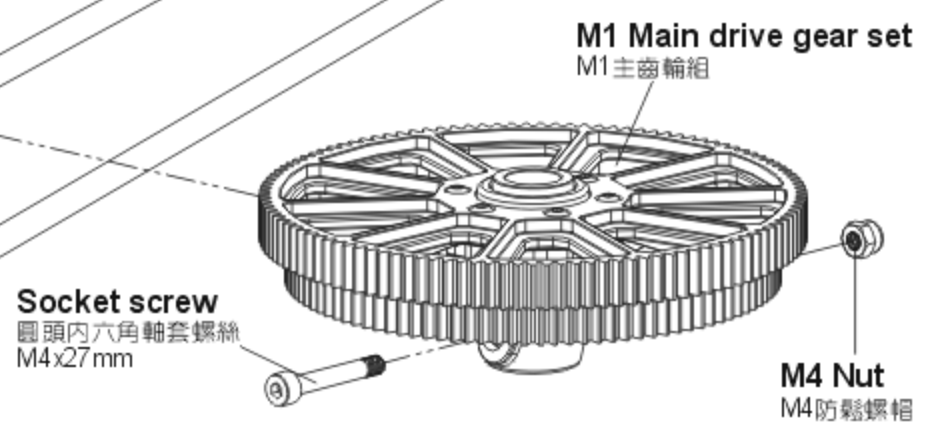

**700FLZ4A**

- Ball link (連桿頭 x 4)

**700FLZ4**

- Linkage rod(D) (連桿(D) (1.96x39.5mm) x 2)

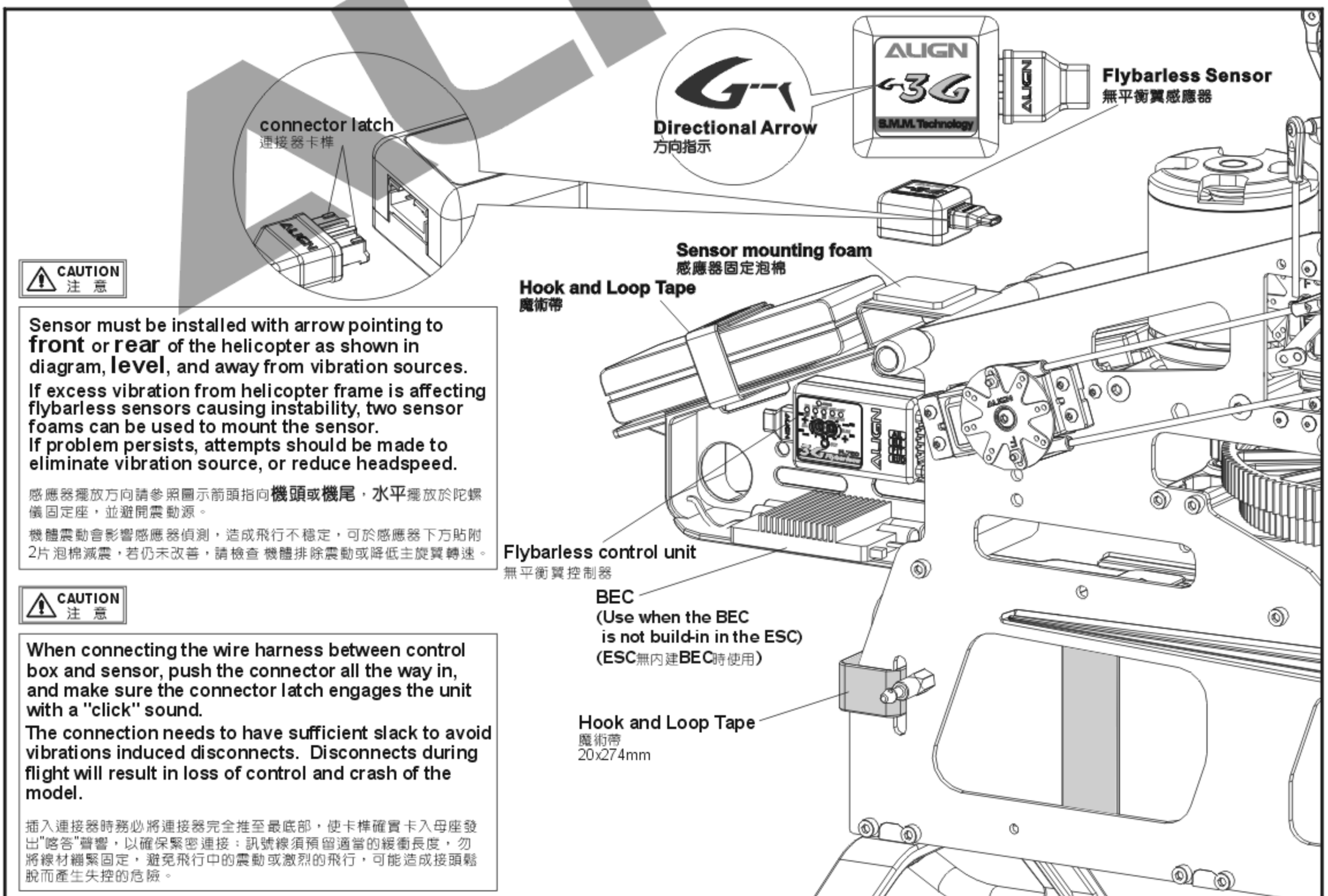
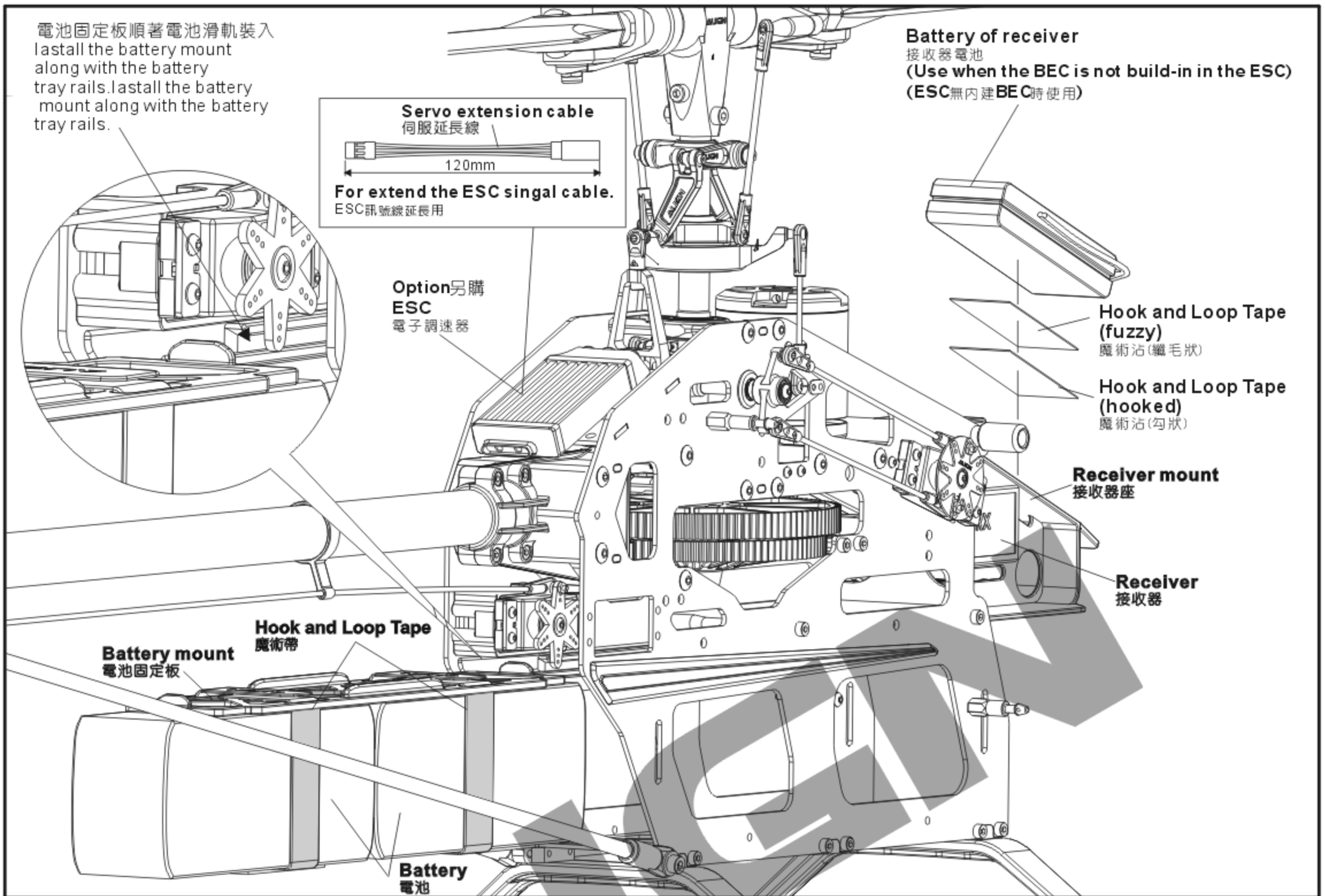

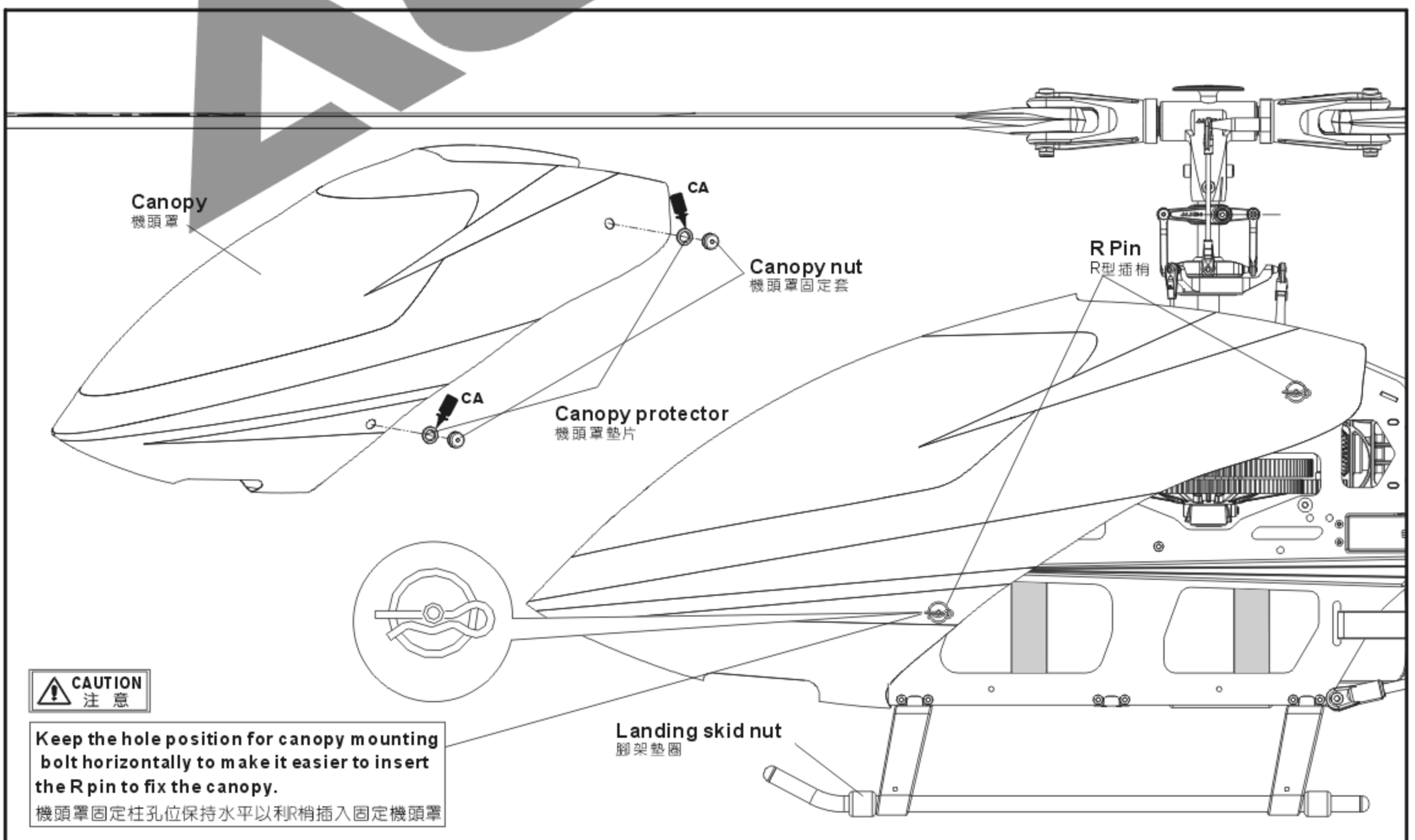
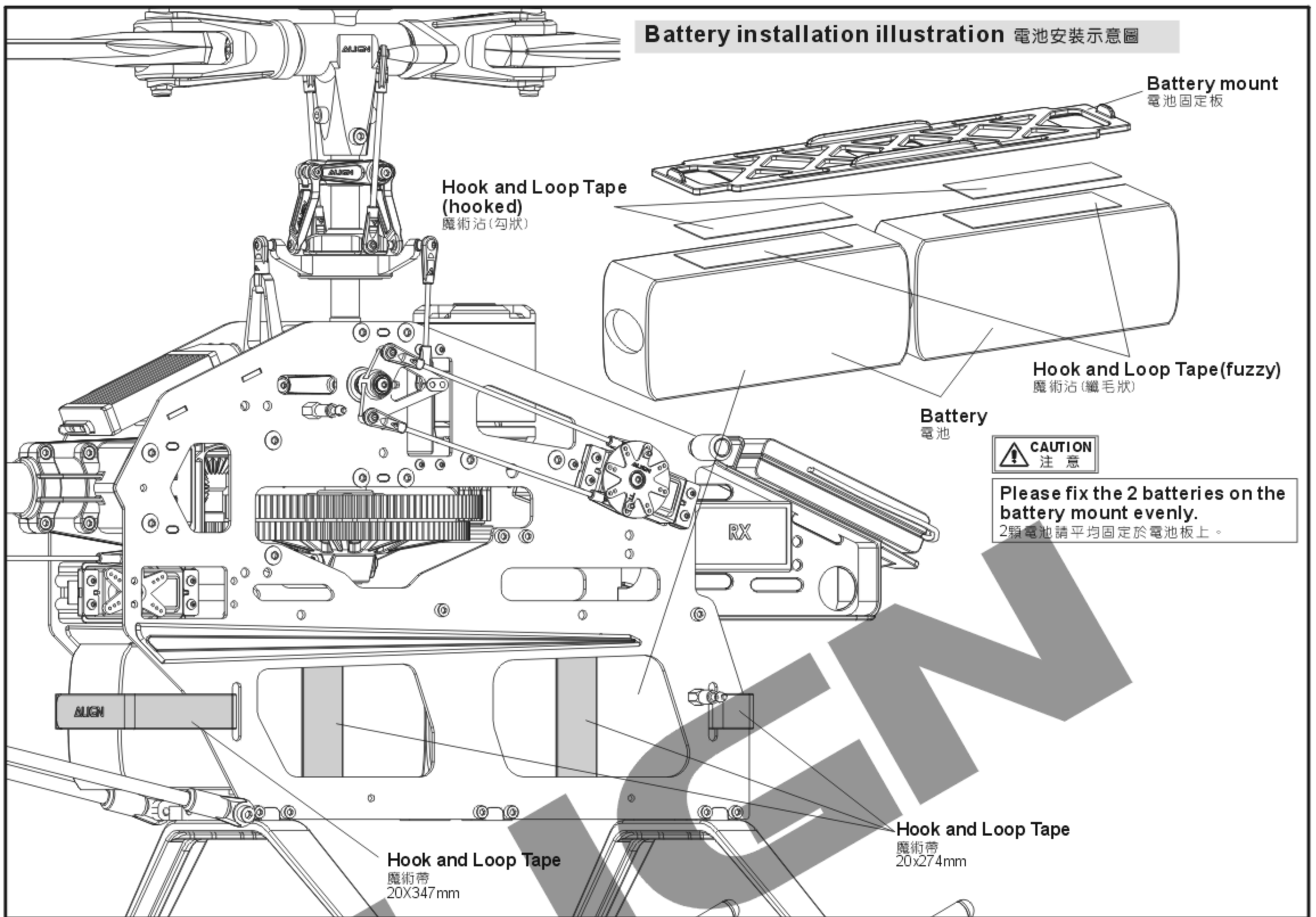

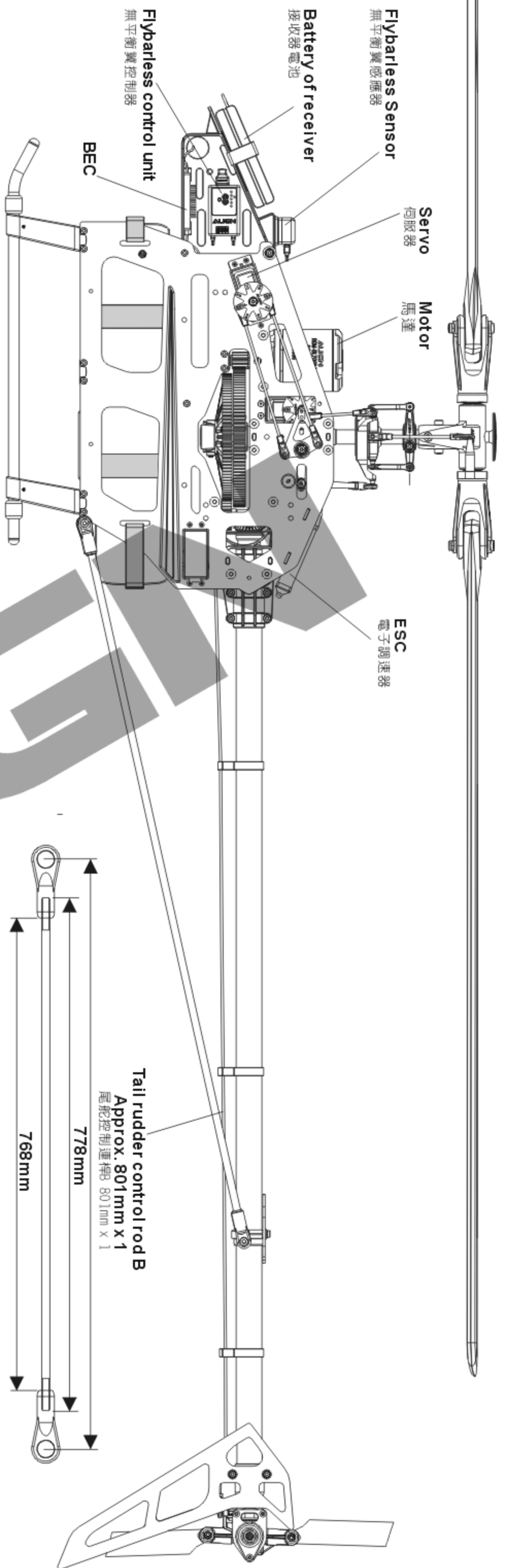

**PARTS IDENTIFICATION AND CONNECTION ILLUSTRATION 各部位名稱與接線示意圖**

Flybarless Sensor 無平衡翼感應器

Flybarless Control Unit 無平衡翼控制器

Insert plugs into receiver as per labels 請依標示插入接收器孔位

BATTERY

dual power bus receiver or dual output BEC. 雙電源接收器或雙電源BEC

THR 油门

AIL 副翼

ELE 升降舵

PIT 俯仰

RUD 方向舵

Step down Voltage Regulator (optional) 降壓器(選用)

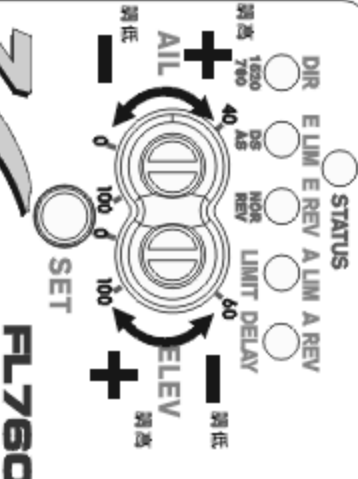

**Status LED 狀態指示燈**  
**Setup Indicator 功能設定指示燈**  
**Elevator Gain 升降舵感度調整旋鈕**  
**SET Button 設定鍵**  
**Aileron Gain 副翼感度調整旋鈕**

**Insert plugs into receiver as per labels 請依標示插入接收器孔位**

**BATTERY**  
 dual power bus receiver or dual output BEC. 雙電源接收器或雙電源BEC

**THR 油门**  
**AIL 副翼**  
**ELE 升降舵**  
**PIT 俯仰**  
**RUD 方向舵**

**Step down Voltage Regulator (optional) 降壓器(選用)**

**Cyclic and rudder servos are on independent power bus for compatibility with dual power bus receiver or dual output BEC. (Example: Swashplate servo 7.4V and rudder servo 5.2V)**  
 十字舵與尾舵舵機為獨立電源迴路，可與雙電源接收器或雙電源BEC。(例如：十字舵舵機7.4V - 尾舵舵機5.2V)

The default factory setting for aileron and elevator gain is 50% (dial turned to 12 o'clock position). If left/right or forward/aft oscillation is noticed, reduce the AIL or ELE gain 10 degrees at a time, until the oscillation disappears.

If helicopter drifts left/right or forward/aft during hover, increase the AIL or ELE gain 10 degrees at a time until drifting is eliminated.

副翼與升降舵感度調整旋鈕，出廠設定值為50%(旋鈕指向12點鐘方向)。飛行時若機體有左右抖動或前後抖動時，表示感度偏高，請逆時針調低AIL或ELE感度旋鈕，以每次調整約10度的方式，調整至適當位置。

飛行時若機體有左右飄移或前後飄移時，表示感度偏低，請順時針調高AIL或ELE感度旋鈕，以每次調整約10度的方式，調整至適當位置。

To set this option is to turn on the transmitter and connect to BEC power.  
此項設定只要開啓發射器，接上BEC電源即可進行操作。

**JR Transmitter/Servo JR遙控器對應伺服器關係**

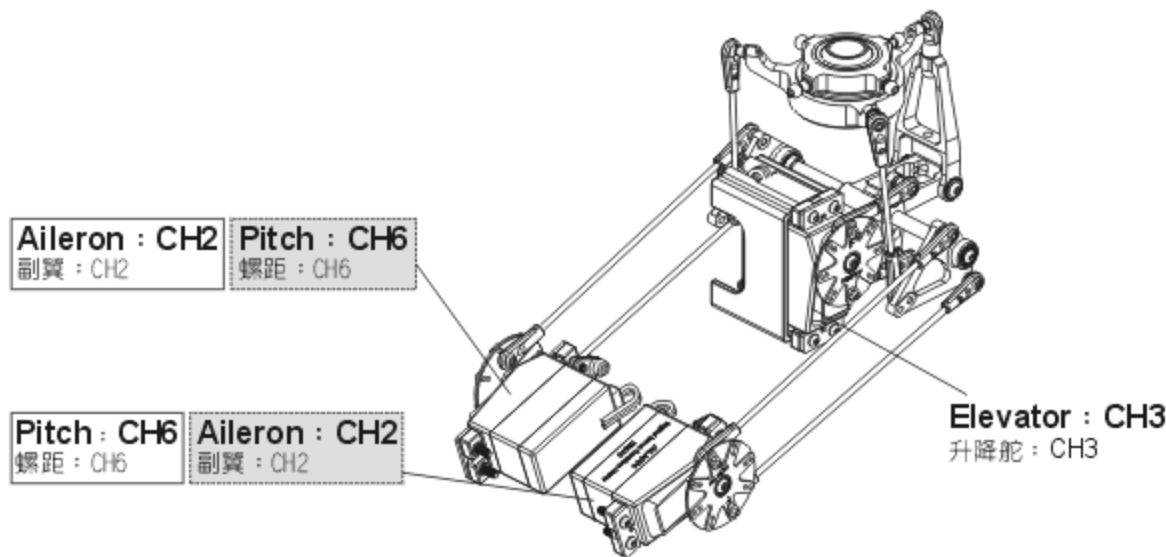

Positions of CH2 · CH6 are exchangeable, After assembling as photo (Note: Set the transmitter under CCPM 120 degrees mode), pull throttle stick (pitch) upward. If one swashplate servo (or two servos) moves downward, adjust reverse switch (REV) on the transmitter to make it moves upward. If three servo move downward, adjust the travel value (+-) of SWASH CH6 on the transmitter to make them move upward. When the actions of Aileron and Elevator are opposite, adjust travel values of SWASH CH2 and Ch3.

CH2 · CH6可互換配置，依圖連結後(注意：遙控器須設定於CCPM 120°十字盤模式)，將油門搖桿(Pitch)往上推，若十字盤伺服器有1個或2個往下移時，請調整遙控器的反轉開關(REV)使伺服器往上，若3個伺服器同時往下移時，請調整遙控器 SWASH CH6 行程量的正負值，使伺服器同時往上平移，副翼與前後動作相反時，同樣調整 SWASH CH2 · CH3 行程量正負值。

**FUTABA/HITEC Transmitter/Servo FUTABA/HITEC遙控器對應伺服器關係**

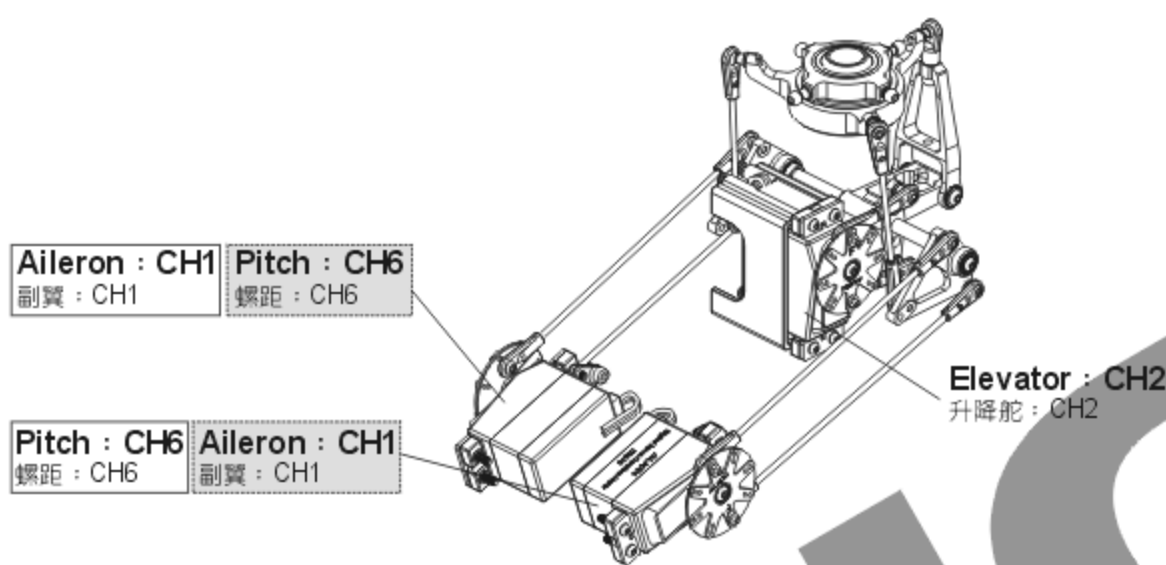

Positions of CH1 · CH6 are exchangeable, After assembling as photo (Note: Set the transmitter under CCPM 120 degrees mode), pull throttle stick (pitch) upward. If one swashplate servo (or two servos) moves downward, adjust r everse switch (REV) on the transmitter to make it moves upward. If three servo move downward, adjust the travel value (+-) of SWASH CH6 on the transmitter to make them move upward. When the actions of Aileron and Elevator are opposite, adjust travel values of SWASH CH1 and Ch2.

CH1 · CH6可互換配置，依圖連結後(注意：遙控器須設定於CCPM 120°十字盤模式)，將油門搖桿(Pitch)往上推，若十字盤伺服器有1個或2個往下移時，請調整遙控器的反轉開關(REV)使伺服器往上，若3個伺服器同時往下移時，請調整遙控器 SWASH CH6 行程量的正負值，使伺服器同時往上平移，副翼與前後動作相反時，同樣調整 SWASH CH1 · CH2 行程量正負值。

12.ADJUSTMENTS FOR GYRO AND TAIL NEUTRAL SETTING 陀螺儀與尾翼中立點設定調整

Recommend to choose Head Lock type for Gyro and turn off Revolution mixing(RVMX) mode on the transmitter, then set the gain switch on the transmitter and the gyro to Head lock mode. The gain setting is about 70%, and after transmitter setting, connect to BEC power to work on tail neutral setting.

Note : When turn on BEC power, please do not touch tail rudder stick and the helicopter. Then wait for 3 seconds, make tail servo arm and tail servo at a right angle(90 degrees), tail pitch assembly must be correctly fixed about in the middle of the travel of tail rotor shaft for standard neutral setting.

陀螺儀選擇，建議選用鎖定式陀螺儀，其發射器內陀螺儀設定請關閉根軸混控模式，並將發射器上的感度開關與陀螺儀切至鎖定模式，感度設約 70% 左右，發射器設定完成後接上BEC接收電源，即可進行尾中立點設置。

注意：當啓動BEC電源時請勿撥動尾舵搖桿或碰觸機體，待3秒陀螺儀鎖定後尾伺服器需與尾伺服器約成90°，尾旋翼控制組須正確置於尾橫軸行程約中間位置，即為標準尾中立點設定。

**TAIL NEUTRAL SETTING 尾中立點設定**

After setting Head Lock mode, correct setting position of tail servo and tail pitch assembly is as photo. If the tail pitch assembly is not at the neutral position, please adjust the length of rudder control rod to trim.

陀螺儀鎖定後尾伺服器與尾Pitch控制組正確擺置位置。若尾Pitch控制組未置中時請調整尾控制連桿的長度來修正。

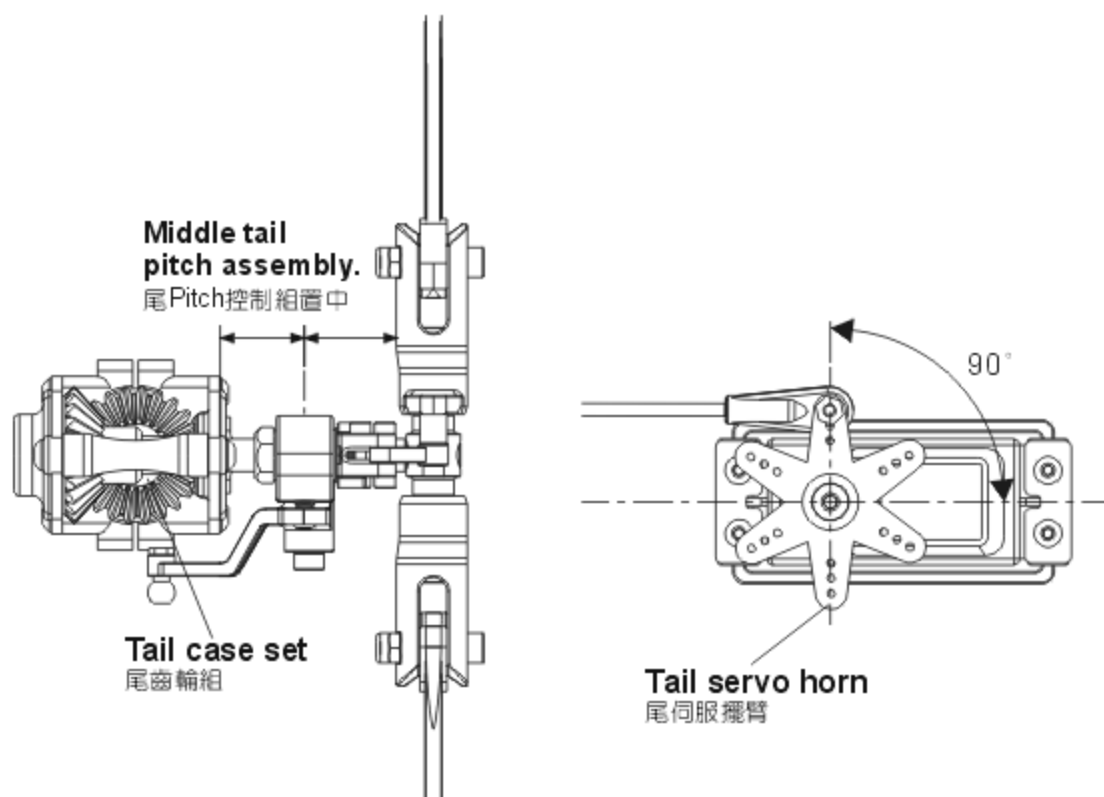

**HEAD LOCK DIRECTION SETTING OF GYRO**

**陀螺儀鎖定方向設定**

To check the head lock direction of gyro is to move the tail counterclockwise and the tail servo horn will be trimmed clockwise. If it trims in the reverse direction, please switch the gyro to "REVERSE".

陀螺儀鎖定方向確認，當手搖尾部反時鐘擺動，尾伺服器應順時鐘修正，反向時請切換陀螺儀上"鎖定反向"開關修正。

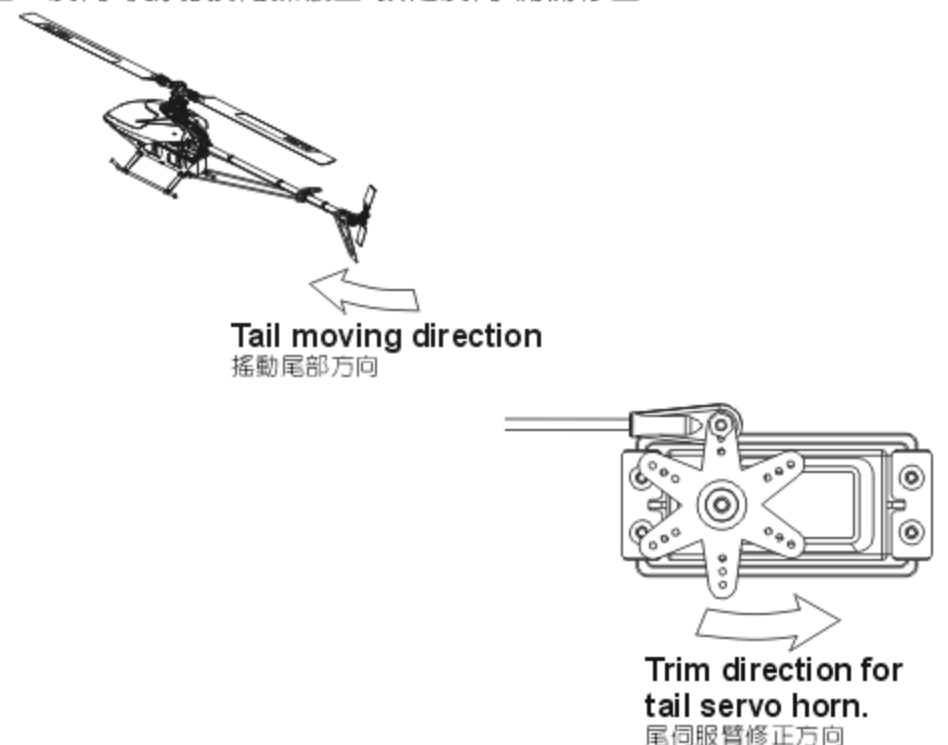

## GENERAL FLIGHT 一般飛行模式

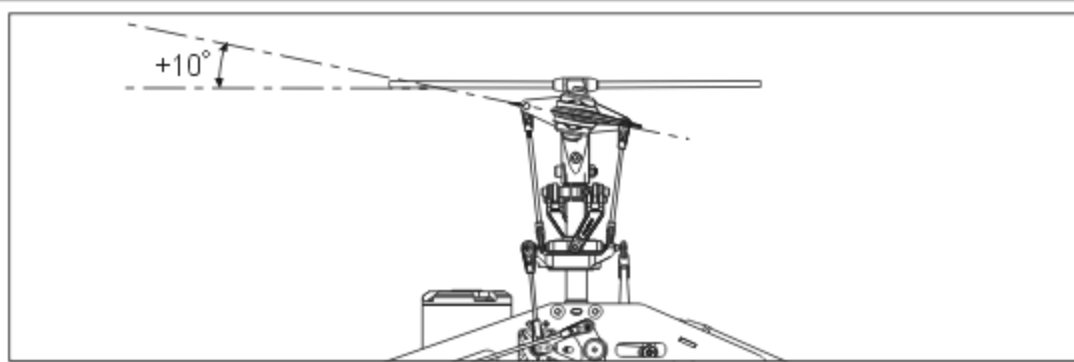

Stick position at high/Throttle 100%/Pitch +10°  
搖桿高速/油門100%/Pitch+10°

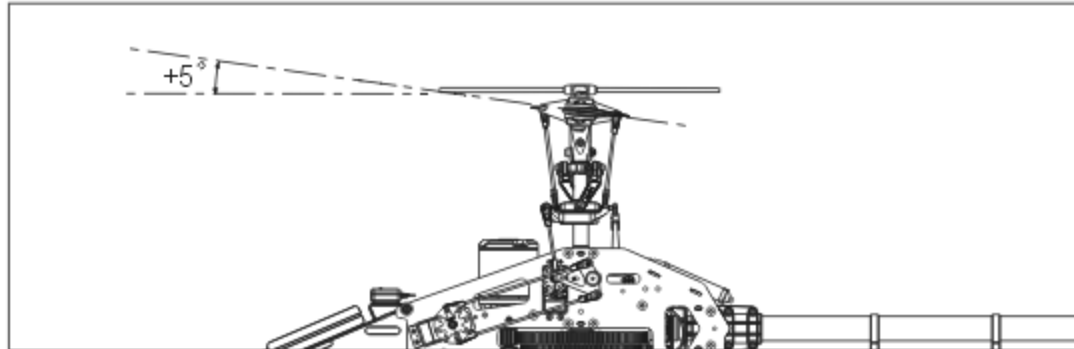

Stick position at Hovering/Throttle 60%/Pitch +5°  
搖桿停懸/油門60%/Pitch+5°

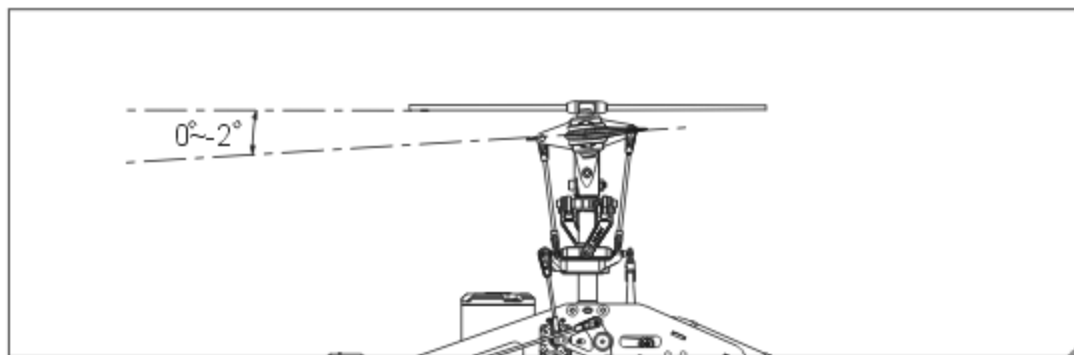

Stick position at low/Throttle 0%/Pitch 0~-2°  
搖桿低速/油門0%/Pitch0~-2°

### GENERAL FLIGHT 一般飛行模式

	Throttle 油門	Pitch 螺距
5	100% High speed 100% 高速	+10°
4	85%	
3	60% Hovering 60% 停懸	+5°
2	40%	
1	0% Low speed 0% 低速	0~-2°

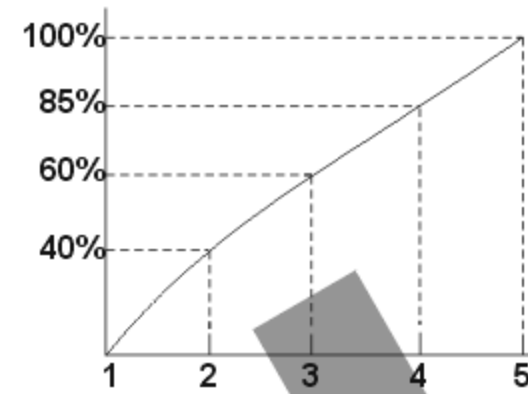

Throttle Curve (Hovering Flight)  
停懸模式油門曲線

## 3D FLIGHT 3D特技飛行模式

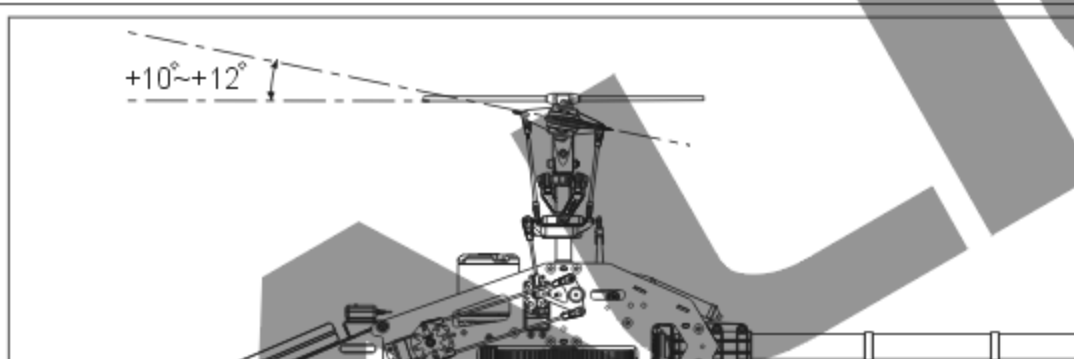

Stick position at high/Throttle 100%/Pitch +10°~+12°  
搖桿高速/油門100%/Pitch+10°~+12°

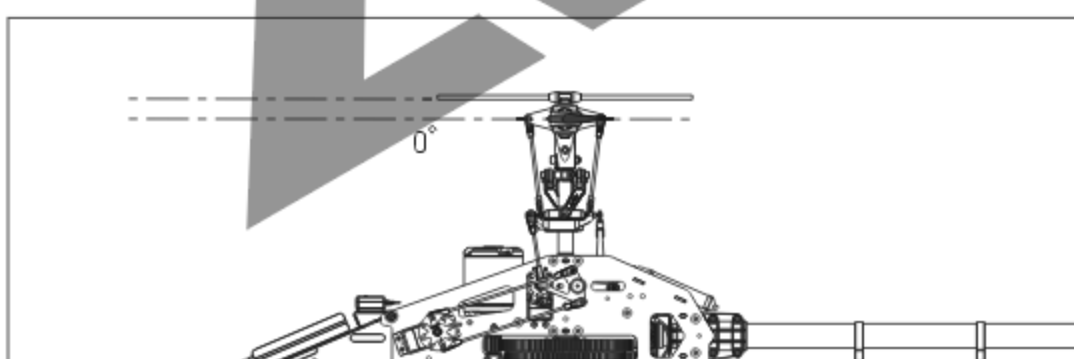

Stick position at middle/Throttle 85%/Pitch 0°  
搖桿中速/油門60%~65%/Pitch 0°

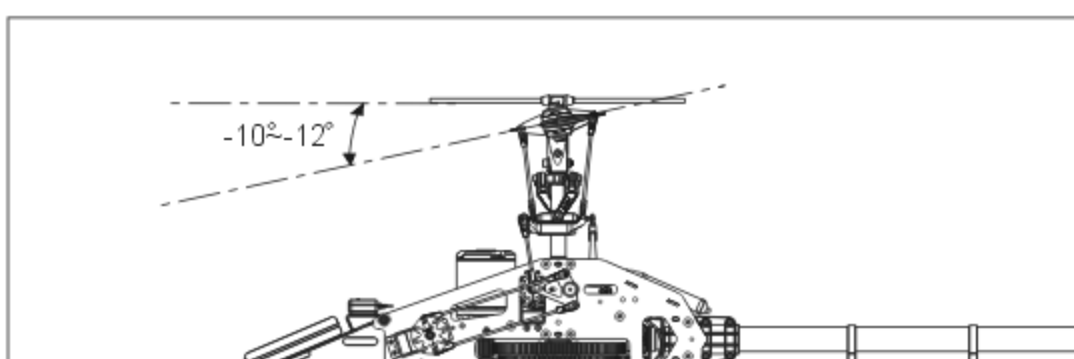

Stick position at low/Throttle 100%/Pitch -10°~-12°  
搖桿低速/油門100%/Pitch-10°~-12°

### IDLE 1 : SPORT FLIGHT

	Throttle 油門	Pitch 螺距
5	100%	+10°~+12°
4	90%	
3	75%	+5°
2	80%	
1	85%	-5°

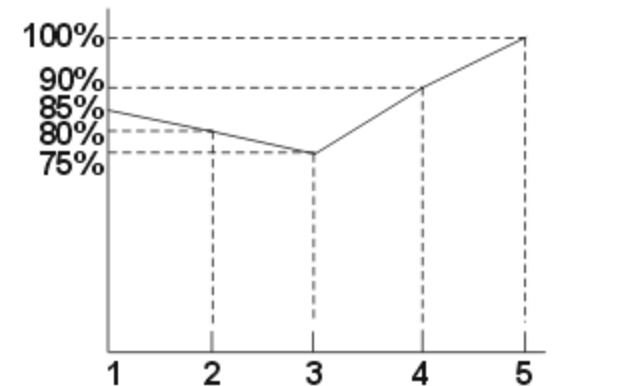

Throttle Curve (Simple Aerobatic Flight)  
空中飛行模式油門曲線

### IDLE 2 : 3D FLIGHT

	Throttle 油門	Pitch 螺距
5	100% High 100% 高	+10°~+12°
3	85% Middle 85% 中	0°
1	100% Low 100% 低	-10°~-12°

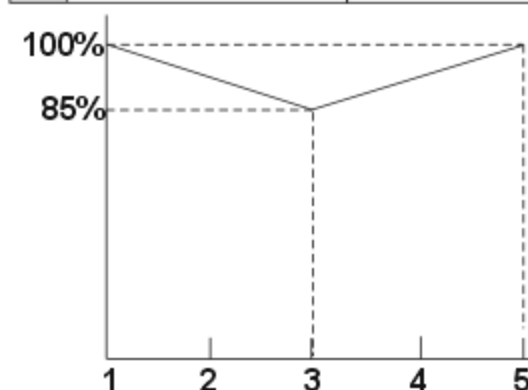

Throttle Curve (3D Flight)  
特技飛行模式油門曲線



1. Pitch range : Approx. ±15 degrees.
  2. If the pitch is set too high, it will result in shorter flight duration and poor motor performance.
  3. Setting the throttle to provide a higher speed is preferable to increasing the pitch too high.
1. 螺距(Pitch)總行程約 ±15°  
2. 過大螺距設定，會導致動力與飛行時間降低。  
3. 動力提昇以較高轉速的設定方式，優於螺距調大的設定。

**FEATURES 產品特色**

- 3Axis** **3-axis gyroscopic flybarless system to simulate the stability of mechanical flybar system, yet at the same time achieving agile 3D performance.**  
3軸陀螺儀無平衡翼系統，可模擬有平衡翼系統的穩定性，更有靈活的3D性能。
- SMM** **Utilizes Silicon Micro Machine (SMM) sensors for excellent stability.**  
採用S.M.M. Silicon Micro Machine技術感應器，具有極佳的穩定性。
- 12bit** **12 bit processors providing ultra high resolution, resulting in highly precise controls**  
採用12位元處理器，超高解析度，控制細膩精準。
- Easy** **Software upgradable through PC interface adapter (sold separately)**  
具備可升級程式化介面，可透過傳輸線更新軟體（傳輸線另購）。
- Energy** **Simplest setup process without the need of external devices. Setup is done through 5 steps and 2 sensitivity adjustments. Rudder setup is identical to GP780 gyro, minimizing learning curve.**  
設定簡單不需額外的介面，只需五個步驟、兩個感度調整即可完成所有設定，尾舵設定和GP780相同，設定輕鬆上手。
- Stable** **Flybarless system dramatically improves 3D power output and efficiency, resulting in reduced fuel or electricity consumption.**  
無平衡翼系統，可大幅降低3D大動作飛行能量消耗，提供直昇機更大的動力輸出且更加節省燃油或電力。
- Stable** **Highly sensitive gyroscopic sensors combined with advanced control detection routine providing higher hovering and aerobatic stability than other flybarless system.**  
高感度陀螺感測器及先進環路設計，可提供比一般平衡翼系統更佳的靜態及動態穩定性。
- T-REX 250-700** **Suitable for all CCPM and mechanical mixing system.**  
適用於任何比例之對稱式三伺服器CCPM系統及傳統十字盤系統。
- 300Hz** **Compatible with helicopter of all sizes from T-Rex 250 to T-Rex 700.**  
3G Flybarless電子設備相容迷你型直昇機至大型直昇機T-REX250~T-REX700。
- 300Hz** **Innovative pitch gauge as an aid to facilitate pitch adjustments.**  
創新設計的螺距量測器，藉以模擬有平衡翼系統之螺距量測。
- 3V~8.4V** **High frame rate signal output for faster and higher precision servo response.**  
高頻數位輸出訊號，使伺服器的反應更加精準、迅速。
- 25g** **Capable to operate between 3V to 8.4V, compatible with high voltage servos.**  
適用電壓3V~8.4V，支援高電壓伺服器。
- 25g** **Small footprint, light weight, minimalists and reliable design.**  
體積小、重量輕，構造簡單可靠，提供操控者高性能的飛行樂趣。

**3G FLYBARLESS SETUP INDICATORS 功能設定指示燈說明**

**Flybarless system setup mode 無平衡翼系統設定模式：**

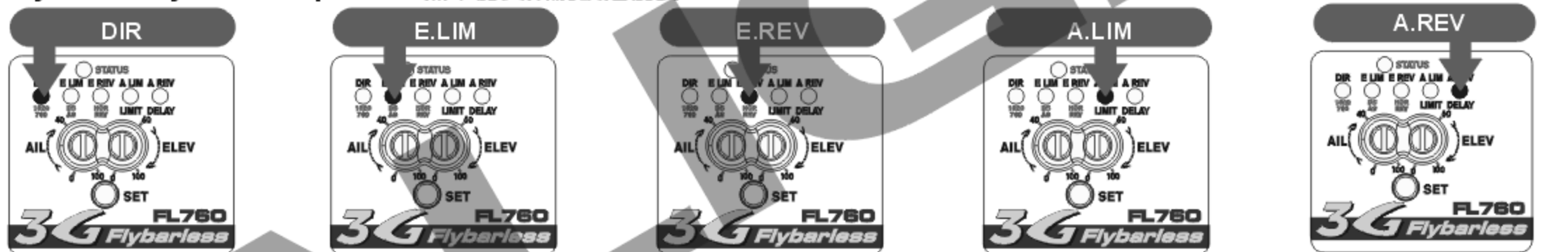

Direct mode bypassing gyro, for mechanical travel and neutral point setup.  
機械行程與中立點設定

Collective mixing type recognition and elevator endpoint settings  
混控辨識及升降舵行程設定

Elevator reverse settings  
升降舵正反向設定

Aileron endpoints settings  
副翼行程設定

Aileron reverse settings  
副翼正反向設定

**Rudder gyro setup mode 尾舵陀螺儀設定模式：**

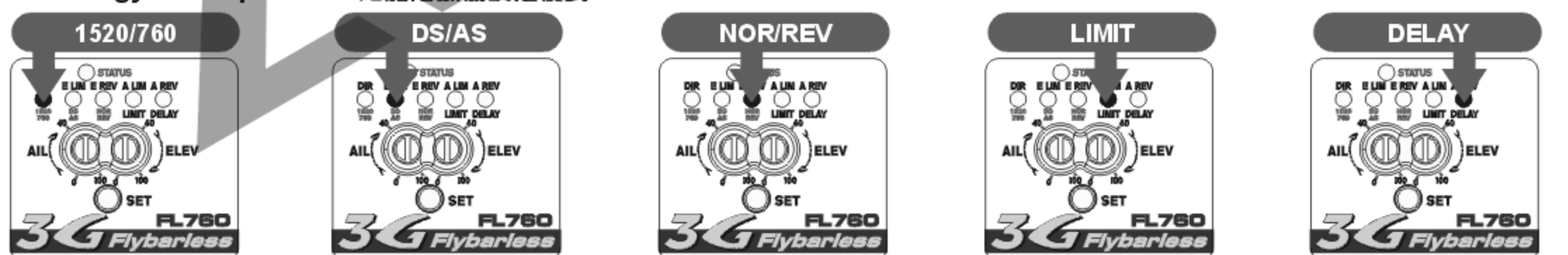

Servo frame rate settings (1520 μs and 760 μs)  
寬頻1520 μs及窄頻 760 μs 伺服器設定

Digital/Analog servo settings  
數位及類比伺服器設定

Rudder Servo Reverse settings  
尾舵陀螺儀正反向設定

Rudder endpoints settings  
尾舵行程設定

Rudder servo delay, and helicopter size settings  
尾舵延遲量及大小直昇機模式設定

**SETUP PRE-CHECK 設定前注意事項**



**While using 3G FBL system, be sure to turn off the following functions in the transmitter**  
使用3G系統若是遙控器有下列功能時請勿開啟功能  
\* Swash Ring \* Linkage Compensation \* Swash Mix  
\* Mixing \* Acceleration

1. Connect the receiver and servos to the flybarless control unit as per diagram found on page 19.
2. Digital servos must be used on cyclic to avoid damage to servos.  
Recommended servo spec: minimum speed 0.10 sec/60, torque 12kg.cm or higher.
3. Transmitter trim tabs must be centered before entering the setup process. It can be moved after setup is complete to trim the heli.
4. 3G Flybarless contains two independent power circuits to enable the use of different voltage sources through the receiver (For example, 7.4V to the cyclic servos, 5V to the gyro and rudder servo). If there is only one 7.4V power source, a step down voltage regulator is required (available separately) to prevent rudder servo from burning out.



**To prevent voltage instability, do not use step down voltage regulator if power source is already at 5V. Please consult your servo manuals and ensure proper voltage are supplied to the servos.**

5. When the 3G flybarless system is installed for the first time, a few simple setup steps and fly tests need to be performed in the flybarless setup mode. These steps need to be performed only during initial setup, and does not need to be repeated for subsequent flights. Just power up the system normally, check the proper servo operations, and fly. The initial setup procedure only need to be repeated after software upgrade, pitch range reset, or subtrims are added in the transmitter.

1. 將接收器及伺服器依接線示意圖連接 (請參照第 19 頁)。
2. 十字盤必須安裝數位伺服器，否則會造成伺服器損毀。  
建議規格：速度0.10秒/60° 以內；扭力12kg.cm以上。
3. 進入設定時必須將遙控器的外微調歸零，飛行時再根據飛行狀況調整微調。
4. 3G Flybarless的伺服器輸入電源具有兩組獨立迴路設計，可支援具有雙電源輸出的接收器分開供給不同電壓 (例如：十字盤伺服器輸出7.4V/陀螺儀、尾舵伺服器輸出5V)。當接收器電源僅有7.4V，無提供獨立尾舵5V電源時，可將尾舵伺服降壓器 (選購品) 依接線圖之方式接上，以防止尾舵伺服器因電壓過高而燒毀。  
**CAUTION 注意** 如原本接收器電源為5V，請勿接上尾舵伺服降壓器，以防止電壓不穩。  
各型號伺服器允許之工作電壓不盡相同，請依該伺服器所建議的電壓下使用。
5. 第一次安裝3G Flybarless無平衡翼系統時，必須進入無平衡翼設定模式，進行幾項簡易的安裝設定與飛行測試，完成後即不須再進入此設定模式，只要正常開機，檢查伺服器動作正確後即可飛行；除非要更新程式、重設螺距或有更動遙控器內微調(sub trim)時，必須進入設定模式重設無平衡翼系統。

## FLYBARLESS SYSTEM INITIAL SETUP STEPS 無平衡翼系統設定

### 1. DIR : Direct mode to bypass gyro for mechanical travel and neutral point setup

DIR機械行程與中立點設定模式

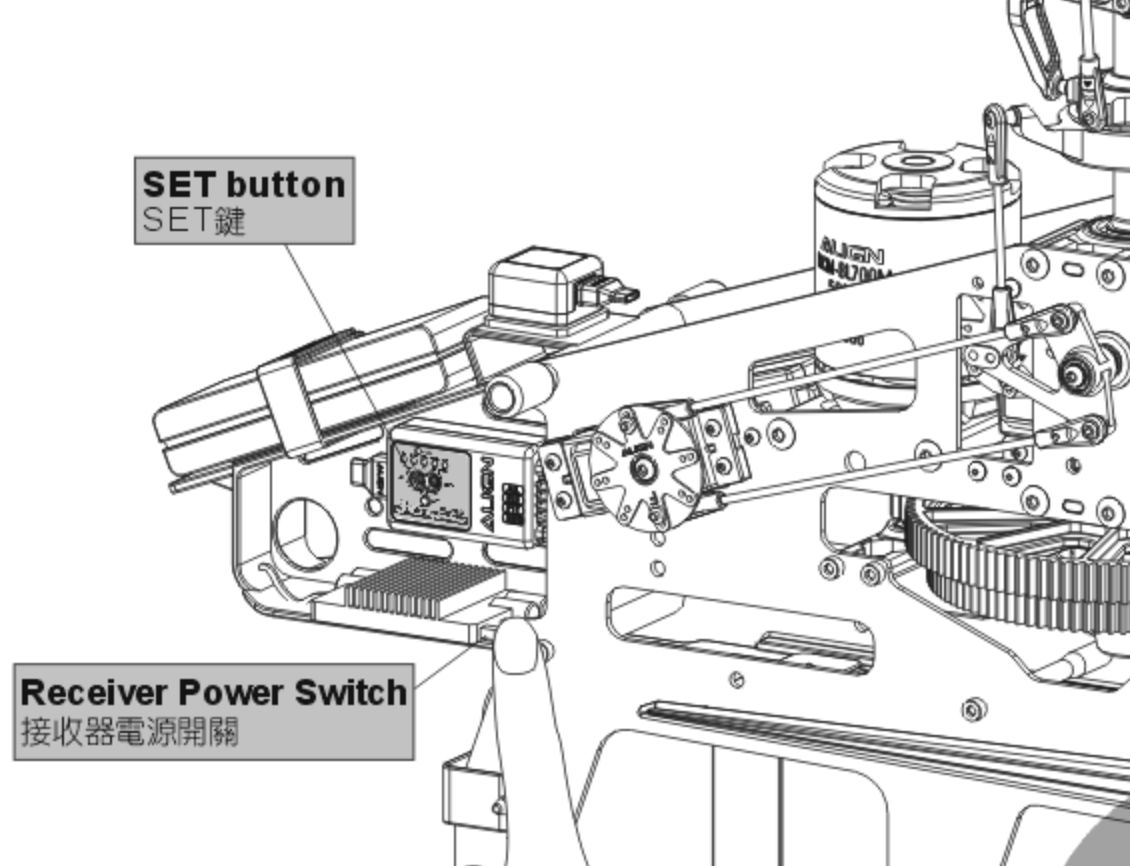

#### Step 1.1 : Enter the DIR settings 步驟1.1 : 進入DIR設定

Press and hold the SET button while powering up the receiver. Release the button when LED 1-5 begin to cycle. The DIR green LED will light up indicating the gyro has been bypassed for neutral and mechanical travel range setup.

按下"SET"鍵不放，並將接收器電源開啓，接著LED1~5(DIR~A.REV)會循序亮起，此時即可以放開按鍵，"DIR"綠燈亮起，則進入3G Flybarless 機械行程與中立點設定模式。



If "STATUS" led flashes in red indicating error entering DIR settings, check connections to the sensor and restart the process.

若"STATUS"亮紅燈閃爍，無法進入DIR模式時，請檢查感應器訊號線連接是否確實後，重新進入DIR設定。



### Transmitter function to servo mapping 遙控器對應伺服器關係

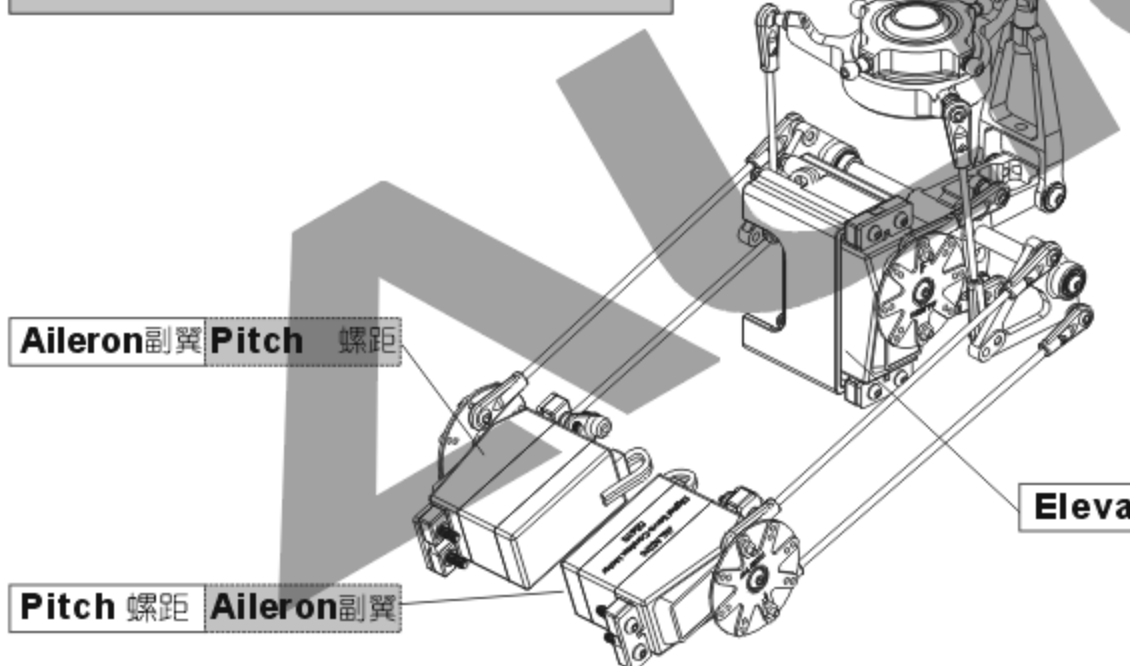

#### Step 1.2 : Swashplate function check 步驟2 : 十字盤作動確認

Verify the correct swashplate movements for PIT, AIL, and ELE inputs. 確認十字盤作動 PIT、AIL、ELE 是否正確。



In case of incorrect servo movement or no movement at all, please check for proper connection between 3G flybarless connection to servos, as well as proper setup on transmitter.

若作動錯誤或伺服器無動作，請檢查3G Flybarless 伺服器訊號線接線以及遙控器設定是否正確。

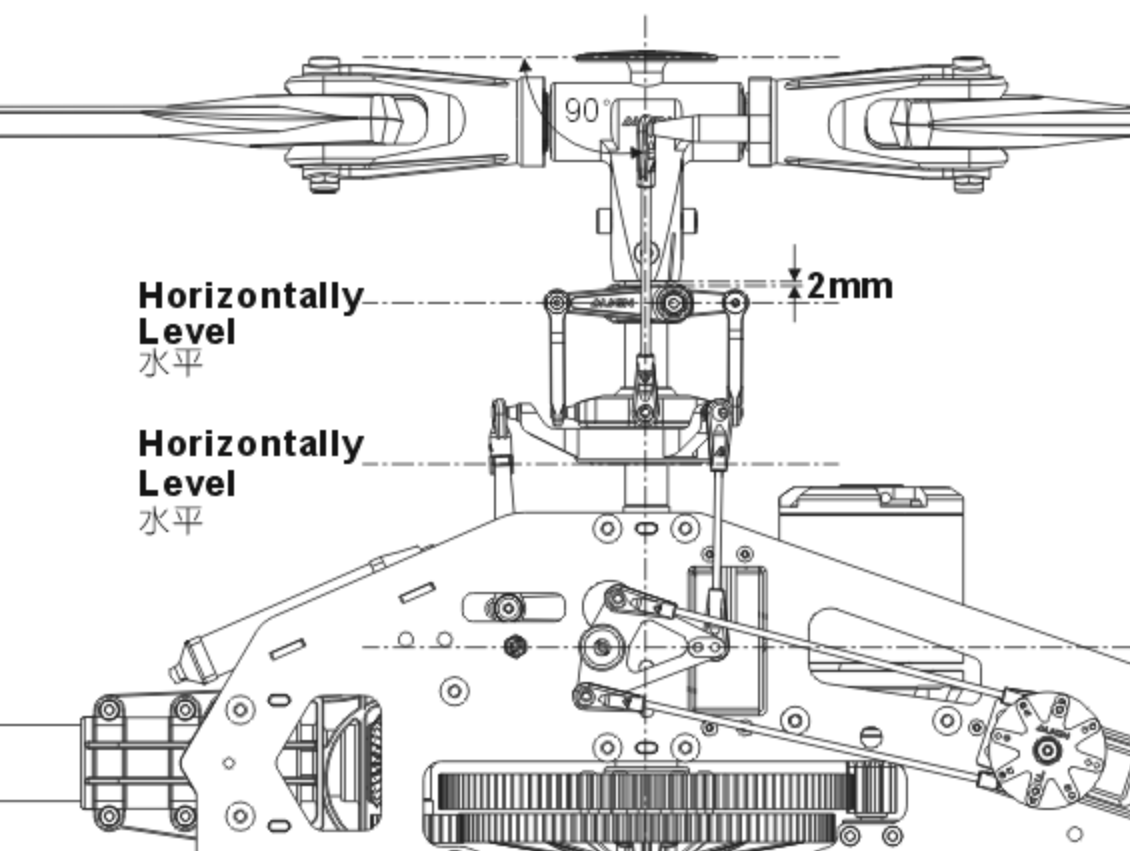

#### Step 1.3 : Mechanical Setup 步驟1.3 : 機械結構設定

Adjust the servo neutral point, mixing base position, and main blade pitch.

請調整伺服器中立點、向位器固定位置與主旋翼角度 (如圖示)。



Pay extra attention to these setup steps. Incorrect neutral points will affect flight stability, and worse lead to loss of control.

本步驟請確實設定，若中立點不正確，不但影響飛行穩定性，更可能造成失控的危險。

Adjust subtrims on transmitter so servo horn is horizontally level 伺服器中立點水平(Subtrim)



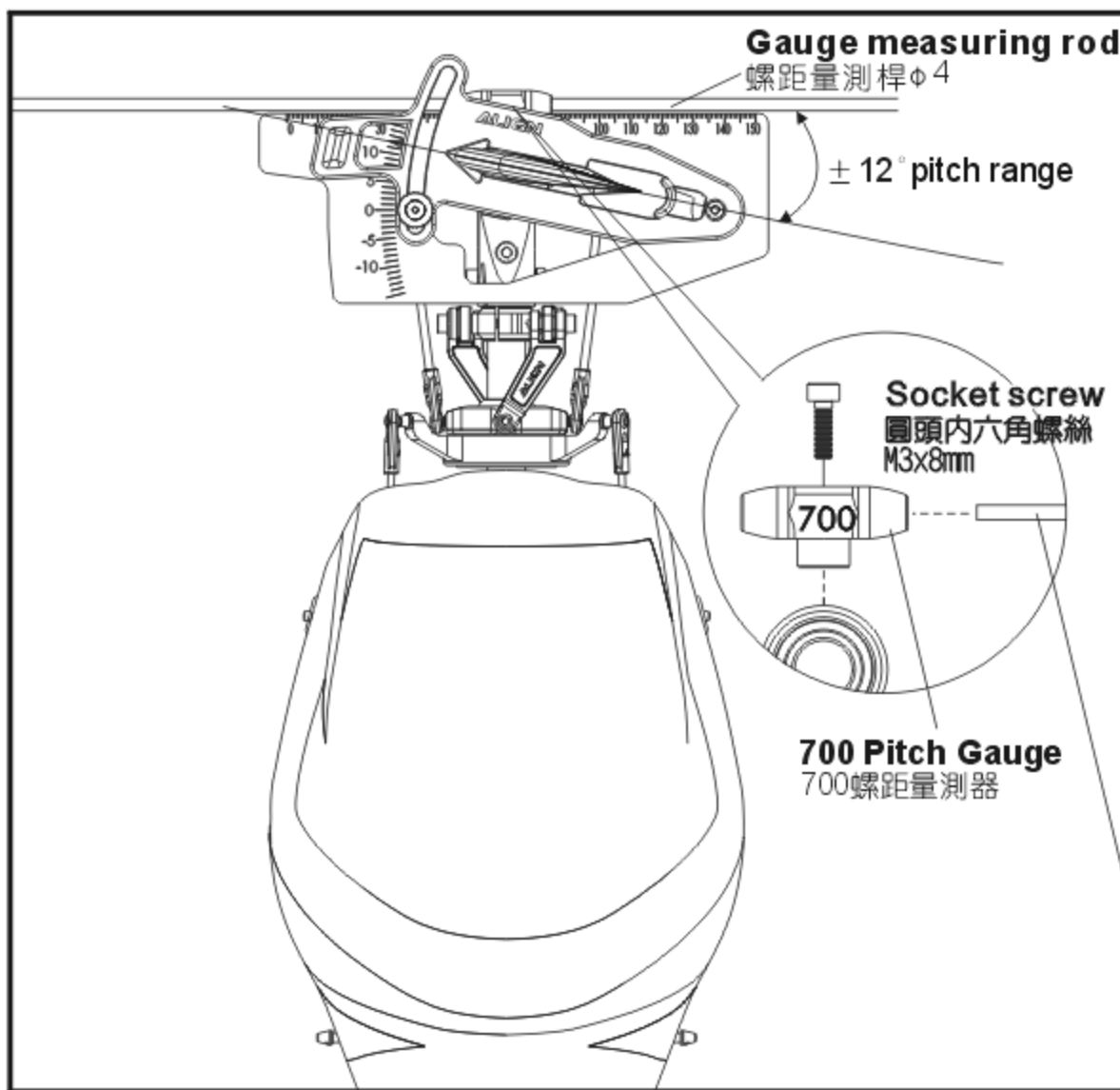

### Step 1.4 : Collective pitch setup 步驟1.4 : 主旋翼螺距(集體螺距)設定

Adjust the maximum collective pitch using the transmitter's swashplate mixing function (pitch swash AFR). Recommended pitch range  $\pm 12^\circ$ , maximum pitch range for advanced pilot shall not exceed  $\pm 14^\circ$ .  
建議螺距設定  $\pm 12^\circ$ ，高階使用者不超過  $\pm 14^\circ$  為限。



Do not adjust individual servos endpoints through the servo ATV/AFR function, use only swashplate mixing adjustments. Should any changes made to the endpoints or subtrims on the transmitter in the future, the flybarless system initial setup must be performed again.

CCPM系統調整行程量時，須從遙控器Swash十字盤混控比率 (Pitch swash AFR) 調整，勿去調整個別伺服器的ATV行程量。爾後遙控器的內微調如有變更，必須重新進行Flybarless各項設定。

**While using 3G FBL system, be sure to turn off the following functions in the transmitter**

使用3G系統若是遙控器有下列功能時請勿開啓功能

- \* Swash Ring
- \* Linkage Compensation
- \* Swash Mix
- \* Mixing
- \* Acceleration

Use the included pitch gauge and the Gauge measuring rod to aid the adjustment of pitch.

利用隨附的螺距量測器與螺距量測桿，模擬有平衡翼系統之螺距量測。

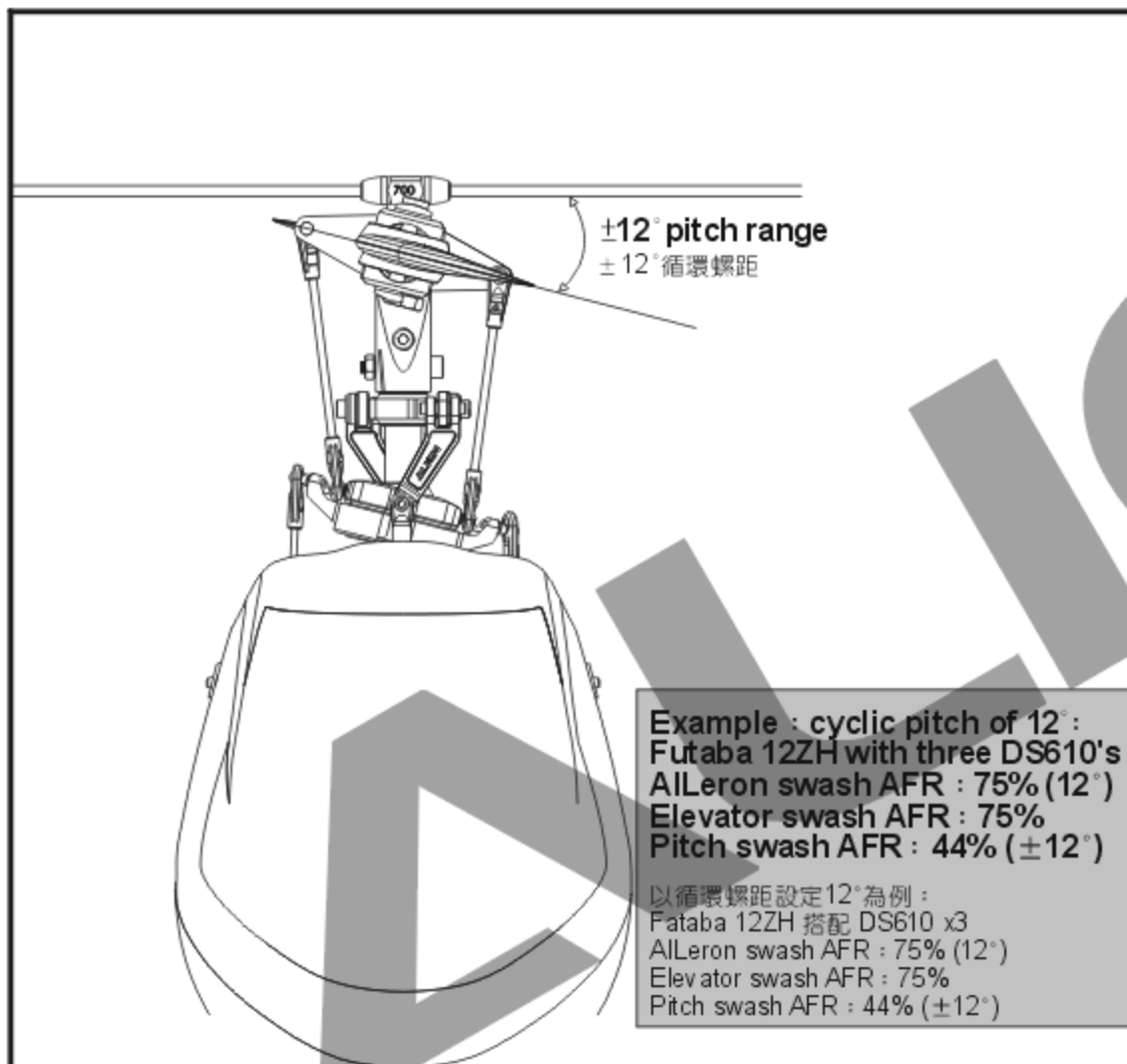
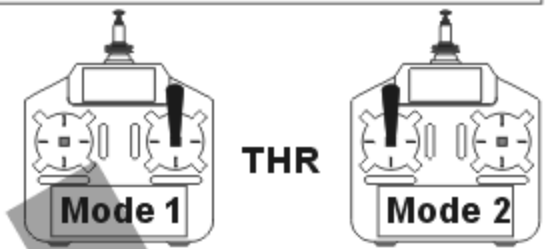

### Step 1.5 : Cyclic pitch setup 步驟1.5 : 循環螺距設定

**Maximum cyclic pitch setup: With main blade parallel to helicopter body, move the transmitter aileron stick all the way left, and adjust the AIL mixing percentage in SWASH settings until main blade pitch are 12 to 14 degrees.**

十字盤循環螺距最大角度設定：主旋翼方向與機體方向相同，油門搖桿置於主旋翼角度0度的位置不動，撥動副翼搖桿至最左，調整遙控器Swash中AIL比率，使主旋翼的攻角為原廠建議值  $\pm 12^\circ$ 。

※Recommended pitch range  $\pm 12^\circ$ , maximum pitch range for advanced pilot shall not exceed  $\pm 14^\circ$ .

※建議一般設12度、高階使用者不超過14度為限。



Adjustments to the CCPM servos endpoints should be done through transmitter's swashplate mixing function (AIL swash AFR). Do not adjust individual servos endpoints through the servo ATV/AFR function. Should any changes made to the endpoints or subtrims on the transmitter in the future, the flybarless system initial setup must be performed again.

CCPM系統調整行程量時，從遙控器Swash十字盤混控比率做調整，勿去調整個別伺服器的ATV行程量。爾後遙控器內微調如有變更，必須重新進行Flybarless各項設定。

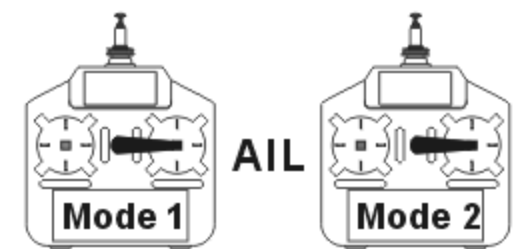

## 2.E.LIM swashplate mixing type recognition and elevator endpoint setup :

E.LIM十字盤混控辨識及升降舵行程量設定模式 :

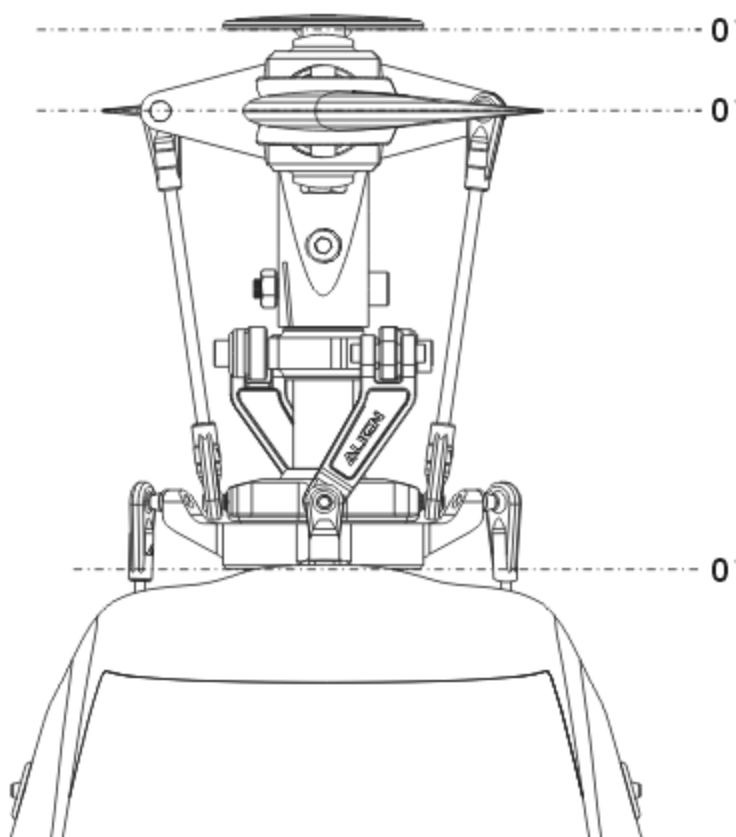

### Step 2.1 : Entering E.LIM setup mode 步驟2.1 : 進入E.LIM設定

While keeping swashplate level and main pitch at zero degrees, press the SET button to register the neutral point and enter E.LIM setup mode. The E.LIM LED will lit up after DIR turns off.

保持十字盤為水平、旋翼角度為零度的狀態下，接著按下"SET"鍵DIR燈將熄滅，E.LIM燈將會亮起，進入"E·LIM升降舵行程量"設定模式。



**The throttle stick position where main pitch is 0 degree must be maintained through this setup process.**

油門搖桿須置於主旋翼角度0度的位置，不可再移動。

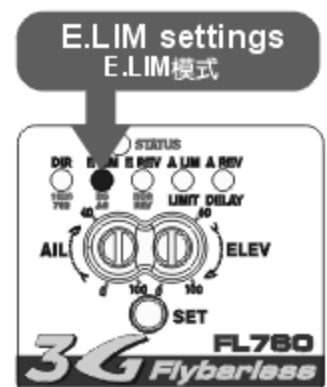

**Step2.2 : Swashplate mixing type recognition and elevator endpoint setup**

**步驟2.2 : 十字盤混控辨識與升降舵行程量設定**

With all channels stationary, move the transmitter elevator stick forward, and then back to center position. This completes the swashplate mixing type recognition process. The control unit will determine the CCPM mixing ratio or traditional mechanical mixing maximum elevator endpoints.

將遙控器升降舵推至最前方(請勿動到其他舵面動作), 再將升降舵搖桿放回中間位置, 完成此模式設定。

讓3G Flybarless解算CCPM混控比例或傳統十字盤模式及前後可用行程。



**Throttle stick position where main pitch is 0 degree must be maintained through this setup process.**

油門搖桿須置於主旋翼角度0度的位置, 不可再移動。

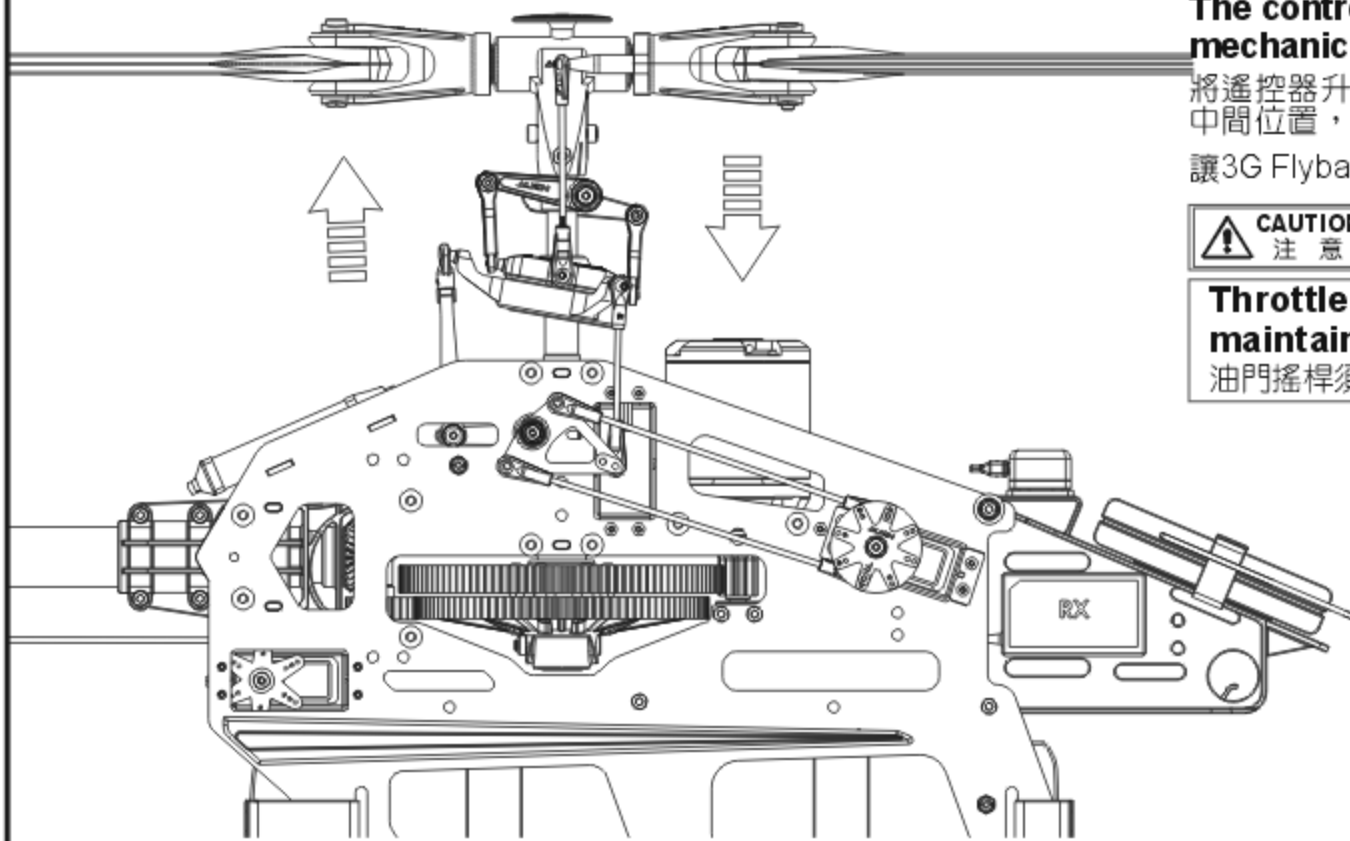

**Throttle stick must be maintained**  
油門搖桿固定

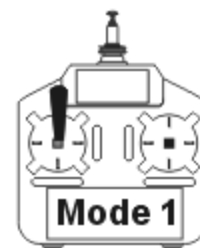

ELE

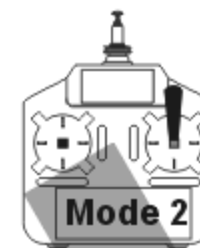

**E.LIM settings**  
E.LIM模式



**3. E.REV elevator reverse setup mode :  
E.REV升降舵陀螺儀正反向設定模式 :**

Press the SET button to enter E.REV setup mode. The E.REV LED will lit up after E.LIM turns off. This setup mode sets the elevator gyro direction

1. Tilt the helicopter forward as shown in diagram, and check if swashplate is tilting correctly toward the back.
2. If the swashplate is tilting at the wrong direction, move the transmitter elevator stick until STATUS LED changes color, and re-check the swashplate tilting direction.

接著按下"SET"鍵, 讓設定模式進入"E.REV 升降舵陀螺儀正反向"設定模式, 此時E.LIM燈熄滅, E.REV燈亮起, 此模式設定升降舵陀螺儀修正方向。

1. 如圖示, 將機身向前傾確認十字盤的修正方向是否正確。
2. 如果十字盤方向修正錯誤, 請撥動升降舵搖桿改變STATUS燈顏色後, 再次確認十字盤修正方向是否正確。

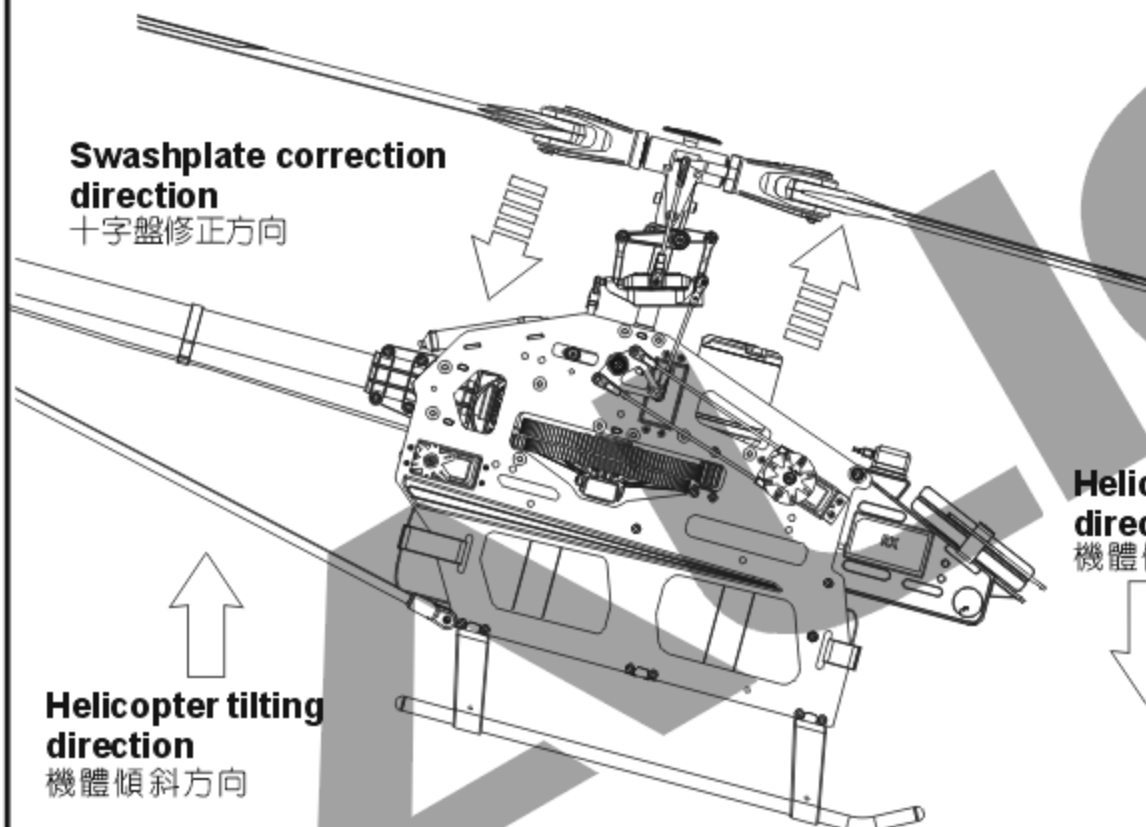

**Helicopter tilting direction**  
機體傾斜方向

**E.REV settings**  
E.REV模式

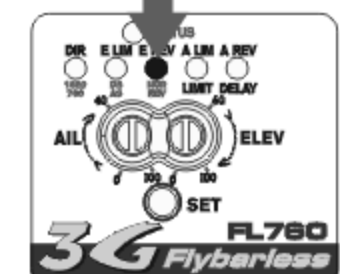

**4. A.LIM aileron endpoints setup :  
A.LIM副翼行程量設定模式 :**

Press the SET button to enter A.LIM setup mode. The A.LIM LED will lit up after E.REV turns off. With all channels stationary, move the transmitter aileron stick to the right, and then back to center position. This completes the aileron endpoint setup process. The control unit will determine the maximum aileron endpoints

接著按下"SET"鍵, 讓設定模式進入"A.LIM副翼行程量"設定模式, 此時E.REV燈熄滅, A.LIM燈亮起。將副翼搖桿向右推到底, 完成後將搖桿置中, 完成此模式設定, 讓3G Flybarless解算副翼可用行程。



**The throttle stick position where main pitch is 0 degree must be maintained through this setup process.**

油門搖桿須置於主旋翼角度0度的位置, 不可再移動。

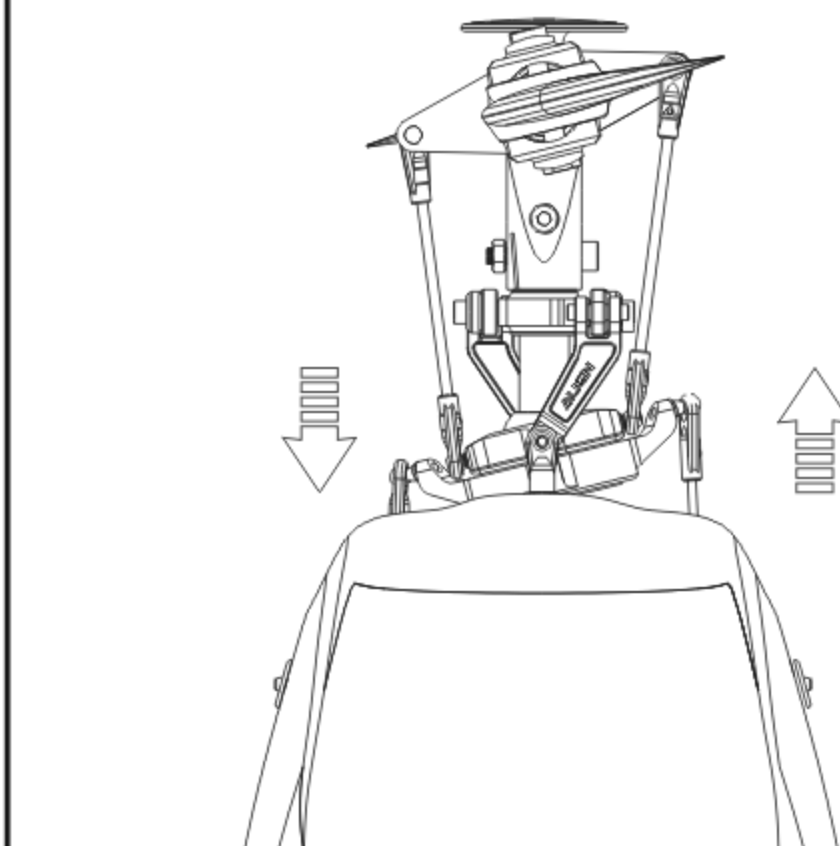

**Throttle stick must be maintained**  
油門搖桿固定

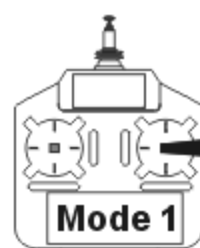

AIL

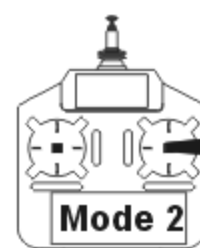

**A.LIM settings**  
A.LIM模式



**5. A.REV aileron reverse setup mode :**  
**A.REV 副翼陀螺儀正反向設定模式 :**

Press the SET button to enter A.REV setup mode. The A.REV LED will lit up after A.LIM turns off. Tilt the helicopter right as shown in diagram, and check if swashplate is tilting correctly toward the left. If the swashplate is tilting at the wrong direction, move the transmitter aileron stick until STATUS LED changes color, and re-check the swashplate tilting direction. Press the SET button again, and the control unit will restart with all LED's flashing. This completes the flybarless portion of the setup process.

接著按下"SET"鍵，讓設定模式進入"A.REV副翼陀螺儀正反向"設定模式，此時A.LIM燈熄滅，A.REV燈亮起。此模式設定副翼陀螺儀修正方向，如果將直昇機往右傾，3G Flybarless應將十字盤向左傾修正，如果反向，可向左或向右推動副翼搖桿，變換"STATUS"不同顏色燈號，更換陀螺儀修正方向。接著按下"SET"鍵完成無平衡翼系統設定，所有LED將閃動，重新開機。



**3G Flybarless system must remain stationary during startup. Do not move the helicopter until the swashplate jumps up and down slightly 3 times, indicating the completion of initialization. (please refer to page 31 step 3)**

3G Flybarless 開機時會進入初始化狀態，此時請勿移動機身，當初始化完成後，十字盤會保持水平上下小幅跳動3次，表示開機完成。(請參考第31頁 步驟3)

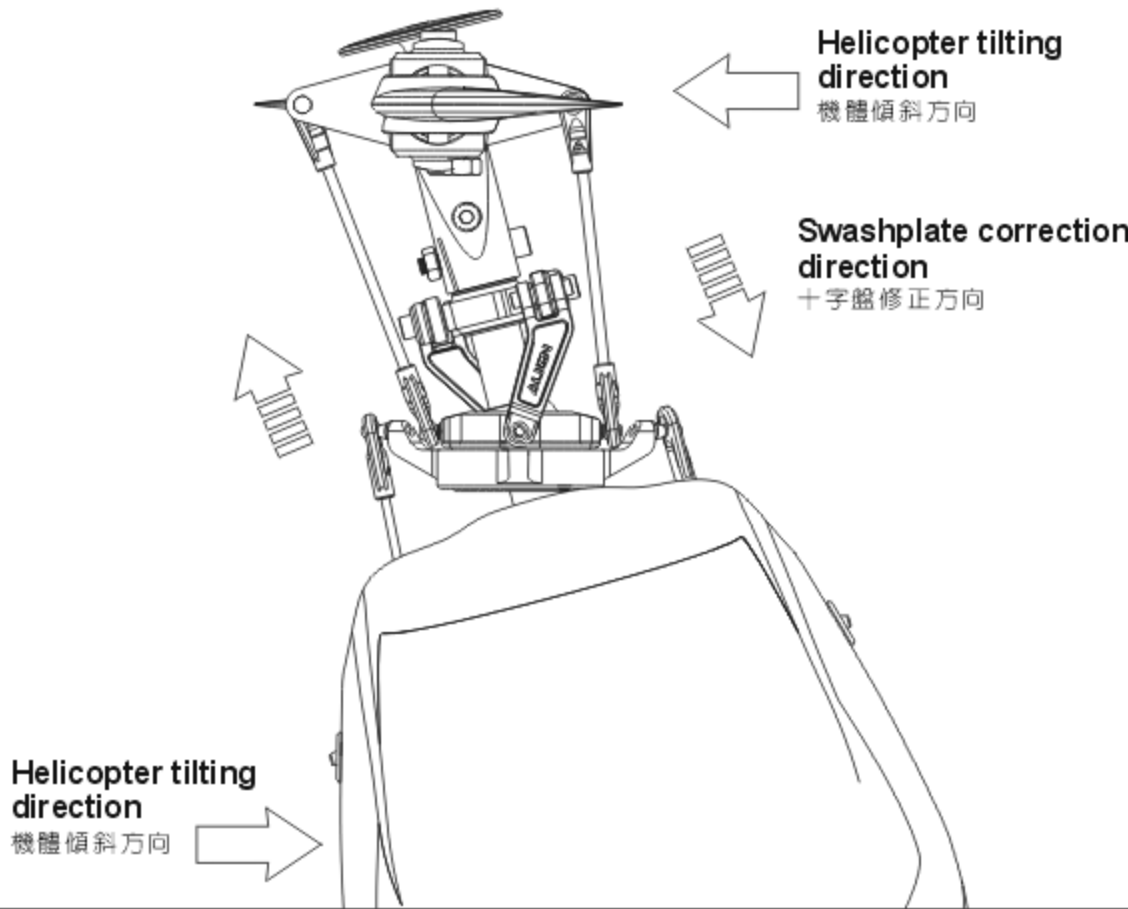
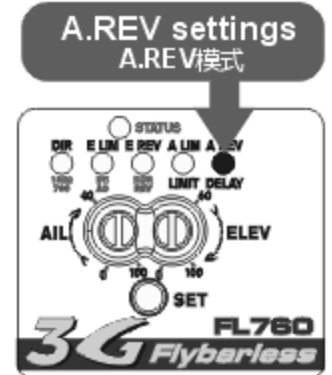

**RUDDER GYRO SETUP 尾舵陀螺儀設定**

After the system reboots, flybarless setup is completed. Now the rudder gyro needs to setup with similar procedure as Align's GP780 gyro. Push and hold the SET button for 2 seconds to enter the rudder gyro setup mode.

If your transmitter has the following settings, please disable it or set the value to zero.

完成開機後Flybarless部分已設定完成，接著要設定尾舵陀螺儀，所有設定如同GP780。於待機狀態下持按"SET"鍵2秒進入尾舵陀螺儀設定。如果您的遙控器有下列功能時，請設定為關閉(OFF)或數值設定為零。

- ATS
- Pilot authority mixing
- Throttle to rudder mixing
- Rudder to gyro mixing
- Pitch to rudder mixing
- Revolution mixing



**3G Flybarless rudder gyro has the factory setting of 1520  $\mu$ s and DS digital servo. Double check your servospec and change the gyro setting as needed to avoid damages to the servo.**

3G Flybarless 尾舵陀螺儀出廠設定值為：1520  $\mu$ s寬頻與DS數位伺服器模式，安裝時請確認您的伺服器規格，避免設定值不同而造成伺服器損壞。

**1. 1520  $\mu$ s (standard) or 760  $\mu$ s (narrow band) servo frame rate setup.**

1520  $\mu$ s (標準)或760  $\mu$ s (窄頻)伺服器設定

3G Flybarless system is compatible with both the 760  $\mu$ s narrow frame rate servos (such as Futaba S9256, S9251, BLS251), as well as the standard 1520  $\mu$ s frame rate servos (most others). Proper frame rate must be selected based on your servo's specifications.

To enter the setup mode : Press and hold the SET button for 2 seconds until STATUS LED flashes. The 1520/760 LED will light up indicating servo frame rate setup mode. Push the transmitter rudder stick left or right to select the frame rate. For example, if rudder is pushed to the left (or right) and STATUS LED turns green, the frame rate is set to 1520  $\mu$ s. To set it to 760  $\mu$ s, the rudder stick need to be pushed from the center to the opposing end 3 times for the STATUS LED to turn red, indicating frame rate set to 760  $\mu$ s.

3G Flybarless panel : Each setting value is labeled on the 3G flybarless control unit with either green or red lettering, which corresponds to the STATUS LED color. Subsequent setup mode is entered by a single press of the SET button. Setup mode will exit if no activity is detected in 10 seconds.

3G Flybarless相容兩種波寬控制系統，若您使用的伺服器屬於760  $\mu$ s系統 (如Futaba S9256、S9251、BLS251)，則必須將3G Flybarless設定於760的模式，其他未標示760  $\mu$ s規格的伺服器，一般皆為1520  $\mu$ s系統，須設定為1520的模式。

進入功能設定模式：持按面板上的"SET"設定鍵約2秒，此時"STATUS"狀態指示燈會開始閃爍，且"1520/760"的功能設定指示燈會亮起，表示進入標準/窄頻伺服器選項，利用遙控器方向舵搖桿的左右方向來選擇設定值，例如方向舵搖桿往左(或右)時，"STATUS"指示燈為綠色，表示設定值為1520  $\mu$ s系統；若要設定為窄頻760  $\mu$ s系統時，必須將搖桿由中立點往相反方向連續撥動3次，使"STATUS"指示燈亮紅色，才會進入760  $\mu$ s系統。

3G Flybarless的面板：標籤上已使用綠/紅色的字體提示"STATUS"燈色所代表的設定值。設定完成後按"SET"鍵一次可進入下一個設定，或是10秒內不做任何設定，系統會自動離開設定模式。

Green LED : 1520  $\mu$ s standard band  
 Red LED : 760  $\mu$ s narrow band  
 綠燈：1520  $\mu$ s寬頻伺服器  
 紅燈：760  $\mu$ s窄頻伺服器

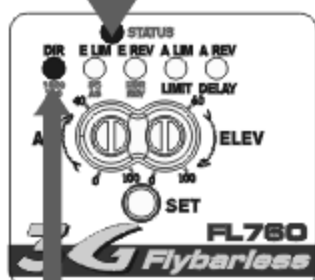

Standard/Narrow band mode  
 寬頻/窄頻模式

Select by moving the rudder stick left and right  
 左右撥動方向舵選擇

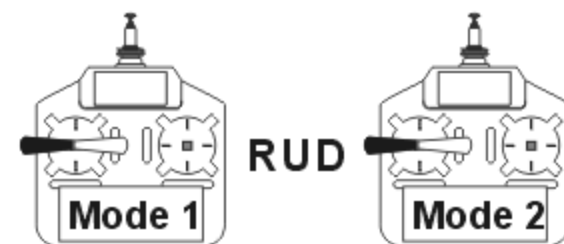

## 2. DS (digital) / AS (analog) servo selection

### DS數位/AS類比伺服器選擇

There is a direct correlation between servos' speed to gyro's performance. Faster servos are able to execute commands from the gyro at faster and higher precision. Due to the high performance gyro sensors used in the 3G flybarless system, premium high speed digital rudder servos are mandatory for optimal tail performance. Some of the recommended rudder servos include Align DS650, DS620, DS520, DS420, Futaba S9257, S9256, S9254, S9253, or other servos with similar specifications.

**Setup method :** Press and hold the SET button for 2 seconds to enter the setup mode, then press the SET button to select DS/AS setup mode, as indicated by the lighting of DS/AS LED. Using the transmitter's rudder stick, select either digital servo DS mode (STATUS LED is green), or analog servo AS mode (STATUS LED is red).

伺服器動作速度攸關陀螺儀的性能，伺服器動作愈快，就能立即反應陀螺儀送出的指令，發揮快速精準的效能；由於3G Flybarless具有相當快速的反應時間與靈敏度，所以建議您搭配高速型數位伺服器，如ALIGN DS650、DS620、DS520、DS420、Futaba S9257、S9256、S9254、S9253或其他相同規格伺服器，以獲得最佳效能。

**設定方式：**持按"SET"鍵2秒進入功能設定模式，再按"SET"鍵選擇DS/AS選項，(DS/AS指示燈亮起)，利用方向舵搖桿選擇數位DS (STATUS為綠燈)或類比AS (STATUS為紅燈)伺服器。

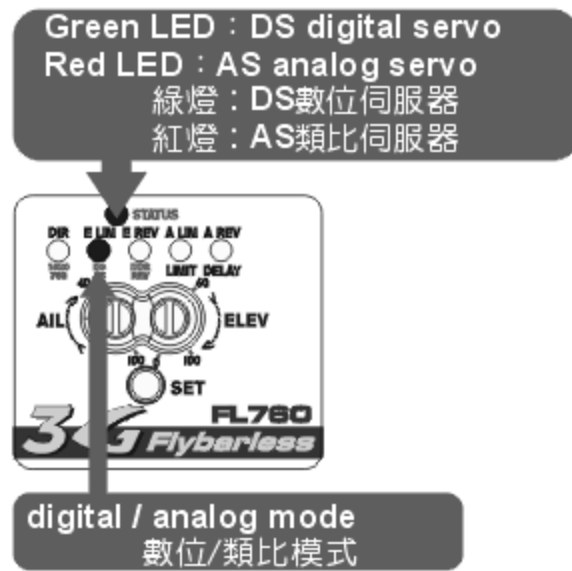

**Using an analog servo in DS mode will cause damages to the servo.**

在DS模式下連接"AS類比伺服器"將導致伺服器燒毀。

**Select by moving the rudder stick left and right**  
左右撥動方向舵選擇



## 3. Rudder servo direction check and link adjustment

### 檢查尾舵伺服器正逆轉方向與調整連桿

Move the transmitter rudder stick left/right, and check for the correct direction of the rudder servo. If needed, servo reverse is done from the transmitter's REV (reverse) function.

For tail pitch adjustment, center the rudder servo by either setting the 3G flybarless to normal rate mode (non-heading lock), or press and hold the SET button for 2 seconds. With the rudder servo centered and servo horn at 90 degrees, adjust the linkage length until tail pitch slider is centered on the tail output shaft as shown in diagram.

左右撥動尾舵搖桿，確認尾舵伺服器移動的方向是否正確，若不正确請更改遙控器上的尾舵伺服器正逆轉方向。

將3G Flybarless切換成非鎖定模式或持按"SET"鍵2秒，使尾舵伺服器保持在中立點的位置上，調整伺服舵片，盡可能使尾舵連桿與伺服擺臂呈90度，接著調整連桿長度使尾Pitch控制組置中。

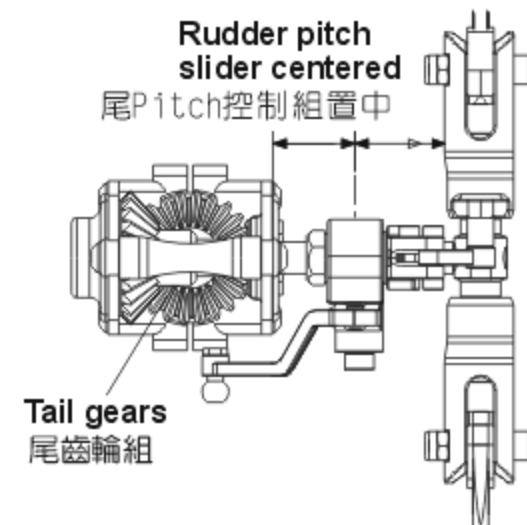
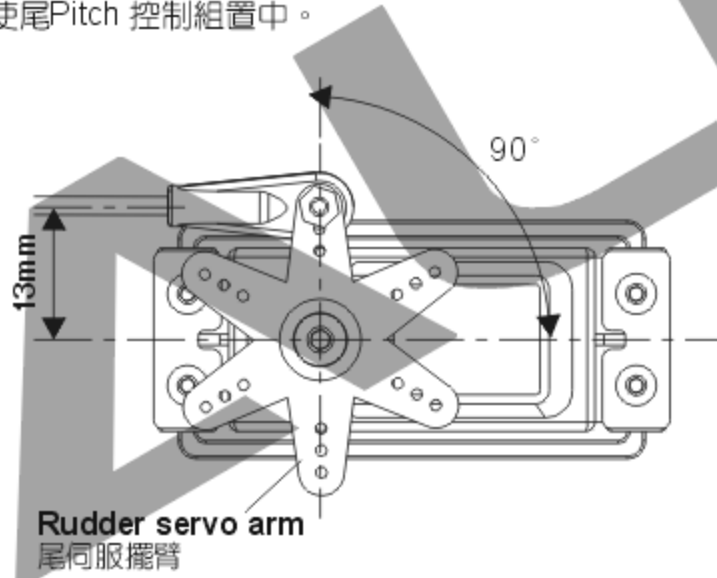

## 4. Gyro NOR/REV setting

### NOR/REV陀螺儀正反向開關設定

Lift up the helicopter by hand, and turn it to the left (yaw). Check if the rudder servo is applying correct compensation to the right. If reversed, set the NOR/REV setting as follow.

**Setup method :** Press and hold the SET button for 2 seconds to enter the setup mode, then press the SET button to select NOR/REV setup mode, as indicated by the lighting of NOR/REV LED. Using the transmitter's rudder stick, select either NOR (STATUS LED is green), or REV (STATUS LED is red).

提起直昇機，將機頭往左擺動，若尾舵伺服器的擺動方向與遙控器的方向舵搖桿打右舵同方向時，表示陀螺儀的動作方向設定正確，若不正确時請更改正反向設定。

**設定方式：**持按"SET"鍵2秒進入功能設定模式，選擇NOR /REV選項，以方向舵選擇NOR (STATUS為綠燈)或REV (STATUS為紅燈)。

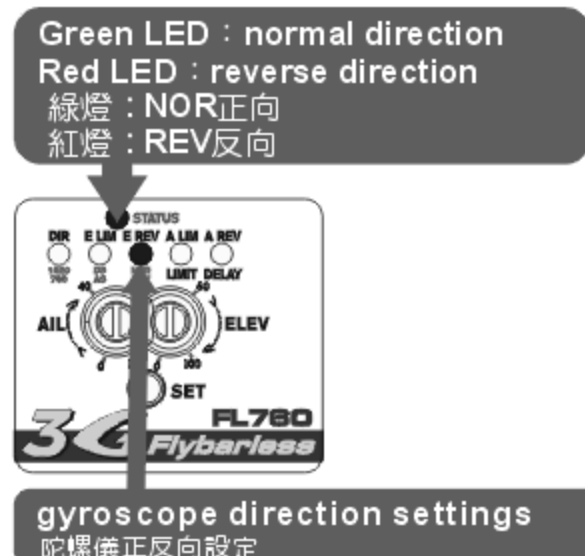

**Select by moving the rudder stick left and right**  
左右撥動方向舵選擇

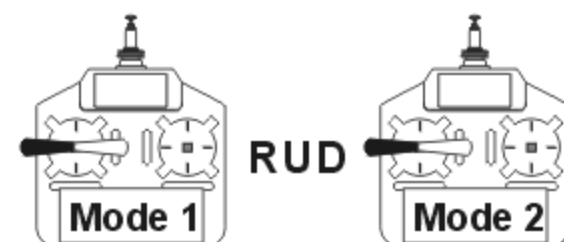

## 5. LIMIT rudder servo endpoint setting

### LIMIT尾舵伺服器行程量調整

Press and hold the **SET** button for 2 seconds to enter the setup mode, then press the **SET** button repeatedly to select **LIMIT** setup mode, as indicated by the lighting of **LIMIT LED**. Push the transmitter rudder stick left until tail pitch slider reaches the end, then center the rudder stick and wait 2 seconds for the **STATUS LED** to flash red. Then push the rudder stick right until tail pitch slider reaches the end, then center the rudder stick and wait 2 seconds for the **STATUS LED** to flash red. This completes the left and right endpoint limit adjustment of servo travel. Insufficient servo travel will degrade helicopter performance, while excessive travel will cause binding and damage rudder servo.

持按"SET"鍵2秒進入功能設定模式，此時尾伺服器會保持在中立點的位置上，選擇LIMIT選項，接著將方向舵搖桿慢慢的往左移動，使尾控制組達到該側的大行程限度後，將搖桿回歸中立點不動，待2秒後"STATUS"指示燈會亮紅燈閃爍，表示左側行程量已記憶；接著將尾舵搖桿向右移動至控制組最大行程限度後，再將搖桿回歸中立點不動，待2秒後"STATUS"指示燈亮紅燈閃爍，即完成左右行程量設定，行程量不足時會影響陀螺儀與直昇機的性能，行程量過大易造成伺服器損壞。

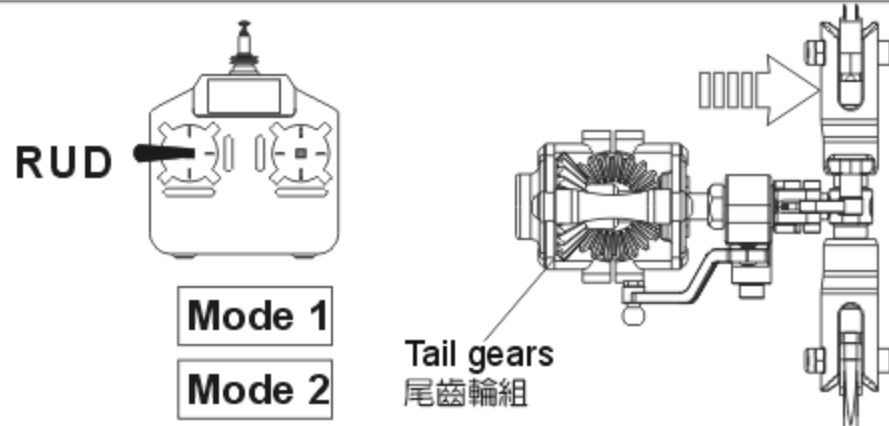

Push the transmitter rudder stick left until tail pitch slider reaches the end, then center the rudder stick and wait 2 seconds for the **STATUS LED** to flash red. This completes the rudder endpoint limit adjustment for the left side.

將方向舵慢慢往左撥動，使控制組達到左舵最大行程限度後，將搖桿回歸中立點不動，待2秒後"STATUS"紅燈閃爍表示左舵行程記憶量完成。

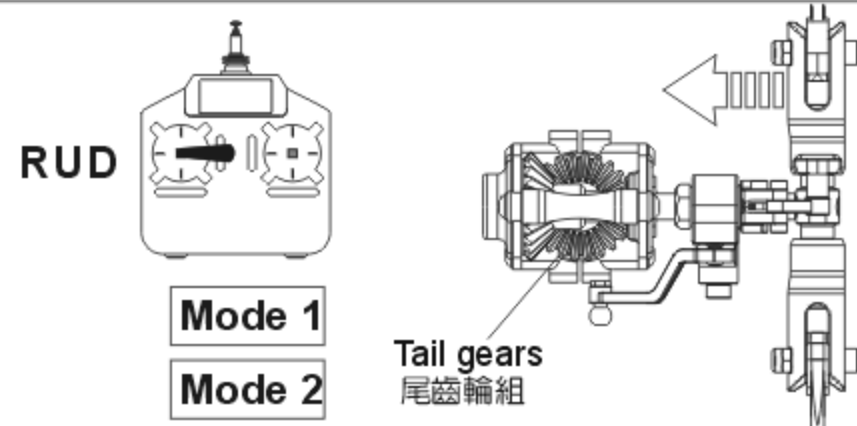

Push the rudder stick right until tail pitch slider reaches the end, then center the rudder stick and wait 2 seconds for the **STATUS LED** to flash red. This completes the rudder endpoint limit adjustment for the right side.

將方向舵慢慢往右撥動，使控制組達到右舵最大行程限度後，將搖桿回歸中立點不動，待2秒後"STATUS"指示燈表示右舵行程記憶量完成。

**Flashing red LED indicates settings have been registered**  
紅燈閃爍時表示記憶完成

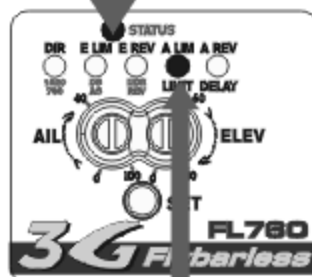

**Endpoint limit settings**  
行程量設定



**Rudder travel limit setting lower than 50% will not be registered. Mechanical fix (moving link ball closer to center of servo horn) is needed for excessive servo travel when LIMIT function is below 50%.**

尾舵行程量設定不可低於50%，否則3G Flybarless將不予記憶，若發生行程量設定後，尾控制組仍會超過最大行程，請將尾伺服臂的球頭向內移動，避免行程不足影響陀螺儀性能。

## 6. Helicopter size and DELAY settings

### 直昇機模式與DELAY控制延遲量調整

This setting includes two functions :

(1) For small helicopters such as T-Rex 250/450, set this setting to small helicopter (**STATUS LED** red). For larger helicopters such as T-Rex 500/600/700 set this setting to large helicopter (**STATUS LED** green).

此設定結合兩項功能：

(1) 3G Flybarless支援小型/迷你型室內電直，請依您直昇機的類型選擇適合的模式，如：T-REX250/450請選擇小型/迷你型模式（設定時"STATUS"指示燈為紅色）；T-REX500/600/700請選中大型直昇機模式（設定時"STATUS"指示燈為綠色）。

**Green LED: suitable for larger helicopters such as T-REX500/600/700**

**Red LED: suitable for smaller helicopter such as T-REX 250/450**

綠燈：適用T-REX500/600/700大型直昇機

紅燈：適用T-REX250/450小型直昇機

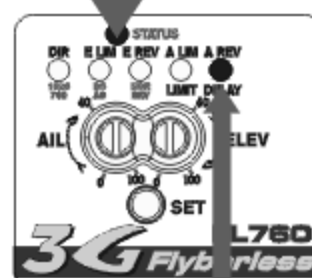

**Helicopter size selection and servo delay settings**  
大小直昇機模式與延遲量設定

**Select by moving the rudder stick left and right**  
左右撥動方向舵選擇

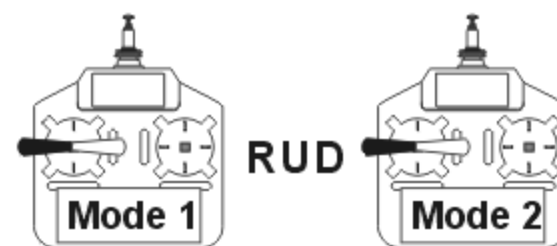

(2) The **DELAY** function is utilized when slower rudder servo causes tail hunting (wagging). This can be observed after a hovering pirouette comes to a stop. If tail hunting occurs, gradually increase **DELAY** value to eliminate it. For best performance, **DELAY** value should be kept as low as possible without tail hunting.

**Setup method** : Press and hold the **SET** button for 2 seconds to enter the setup mode, then press the **SET** button to select **DELAY** setup mode, as indicated by the lighting of **DELAY LED**. The choice of small or large helicopter is done by moving the transmitter rudder stick left or right while observing the color of the **STATUS LED**. For small helicopters **STATUS LED** will be red, and large helicopter will be green. The amount of servo delay is set by how far you push the rudder stick, followed by pushing the **SET** button.

(2) 使用速度較慢的尾舵伺服器較容易產生追蹤現象，當直昇機停懸時，打方向舵使直昇機快速自轉，當方向舵回到中立點使直昇機停止自轉時，此時若發生追蹤現象，請增加控制延遲的設定量，一般而言在不產生追蹤現象的原則下控制延遲的設定量愈小愈好，否則尾舵的動作會變得遲緩。

**設定方式**：持按"SET"鍵2秒進入功能設定模式，選擇至DELAY選項，以方向舵搖桿選擇小型/迷你型電直，

如：T-REX 250/450（STATUS為紅燈），或中大型直昇機如T-REX500/600/700（STATUS為綠燈），若要同時設定DELAY控制量時，則利用方向舵搖桿的位置來設定，搖桿由中立點推至"DELAY"燈開始閃爍時為0%，推至最大行程時控制量為100%，將搖桿推至所需的延遲量時保持不動，並按下"SET"鍵確認，即可同時設定直昇機模式與延遲量。

**Green LED for T-REX700**  
T-REX700設定為綠燈

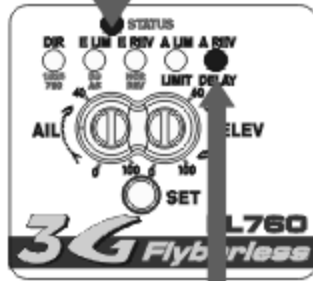

**0% when DELAY LED begins flashing**  
DELAY燈開始閃爍時為0%

**Green LED for T-REX700**  
T-REX700設定為綠燈

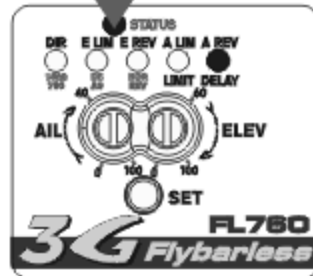

**Gradually move the transmitter rudder stick until DELAY LED begins to flash, the delay value is 0% at this point.**

輕推方向舵搖桿至"DELAY"燈開始閃爍時，延遲量為0%

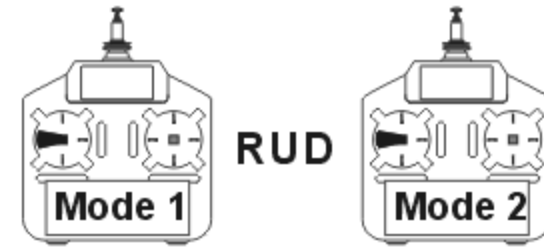

**Continue to move the rudder stick until desired delay value is needed, then press the SET button to register the setting. Maximum is 100% delay, with rudder stick pushed to the end.**

方向舵推至最大行程時，延遲量為100%，將搖桿推至所需的延遲量，按下"SET"鍵確認

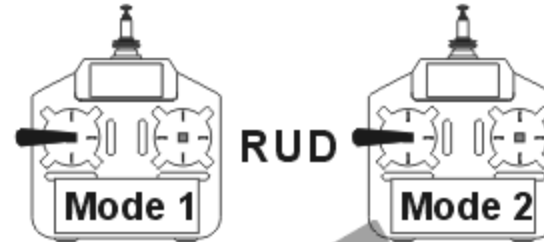

## 7. Sensitivity Adjustment 感度調整

For radio with built in gyro gain settings, gain can be adjusted directly. For example, 50%-100% setting on the radio translates to 0% - 100% gain in the heading lock mode; 50%-0% setting on the radio translates to 0%-100% gain in the normal (non-heading) lock mode.

Actual gain value differs amongst servos and helicopters. The goal is to find the maximum gain without tail hunting. This can only be done through actual flight tests.

The recommended starting point for transmitter's gyro gain setting should be 70~80% for hovering, 60~70% for idle-up. Value should be tuned under actual flight conditions by increasing to the maximum gain without tail hunting.

一般具有陀螺儀感度設定功能的遙控器，可直接進入GYRO功能選項進行感度值的設定，設定值50%則陀螺儀的感度為0，設定值50%~100%，則陀螺儀感度值為鎖定狀態的0~100%；設定值50%-0%，則陀螺儀感度值為非鎖定狀態的0~100%。

感度值的大小會隨著伺服器與直昇機的不同而有所差異，一般而言，在不產生追蹤現象（直昇機尾部出現左右搖擺的情況）的前提下感度值愈高愈好，所以只能透過實際飛行的狀況來進行調整。

進入遙控器感度設定的選項，剛開始停懸時建議先設定在70~80%左右，Idle up飛行時設定在60~70%左右，之後再依實際飛行的狀態再行修正，如果沒有追蹤現象發生時可再調整高感度，若發生追蹤現象時，則調低感度。



**For radios (IE Futaba) using 0-100% as heading lock gain scales, the recommended gain setting is 30% to 35%. For radio that uses the 50 -100% scale (such as JR and Hitec), the recommended gain setting is 70% to 75%.**

鎖定感度值為0~100%的遙控器，如Futaba，建議設定在30~35%左右；鎖定感度值為50~100%的遙控器，如JR、HITEC，建議感度值設定在70~75%左右。

## Specifications 產品規格

1. Operating voltage range : DC 3V~8.4V

2. Operating current consumption : <80mA @ 4.8V

3. Rotational detection rate : ±300°/sec

4. Rudder yaw detection rate : ±500°/sec

5. Sensor resolution : 12bit

6. Operating temperature : -20°C~65°C

7. Operating humidity : 0%~95%

8. Dimension/Weight :

Control unit : 42x26.5x14.5mm/16g

Sensor : 22.3x21.7x14mm/9g

●RoHS certification stamp

1. 適用電壓：DC 3V~8.4V

2. 消耗電流：<80mA @ 4.8V

3. 偵測側滾及前滾角速度：±300°/sec

4. 偵測尾舵角速度：±500°/sec

5. 感應器解析度：12bit(12位元)

6. 操作溫度：-20°C~65°C

7. 操作濕度：0%~95%

8. 尺寸/重量

控制器：42x26.5x14.5mm/16g

感應器：22.3x21.7x14mm/9g

●符合RoHS限用規章

## 15. RCM-BL700M 500KV POWER COLLOCATION REFERENCE 原裝動力數據參考表

ALIGN

BATTERY 電池：ALIGN Li-Poly 44.4V 5200mAh

Motor Pinion Gear 馬達齒輪	Main Rotor Blade 主旋翼規格	Pitch 螺距		Current(A) approx. 電流(A)大約值	Throttle Curve 油門曲線	RPM approx. 主旋翼轉速大約值
12T	690 Carbon Fiber Blades 690碳纖主旋翼	Hover 停懸	+5°	14	0/50/60/85/100%	1700~1800
		Idle	0°	18	85% Middle 中	2200
			0°	23	100/100/100/100/100%	2400 ⚠
			±12°	57		2200

NOTE: 1. Please use a pitch gauge to adjust the pitch value. Incorrect excess pitch setting will result poor helicopter performance and reduce ESC's life and battery's life.

⚠ 2. For the safeties of flight and helicopter structure, please do not equip the power of main blade over 2200 RPM.

註：1. 請務必使用螺距規來量測調整螺距，不正確的過大螺距設定不但無法發揮直昇機的特性，反會影響到無刷調速器與電池的壽命。

⚠ 2. 為了飛行安全與機體結構安全，主旋翼轉速設定禁止超過2200RPM。

## RCM-BL700M MOTOR RCM-BL700M 無刷馬達

### Specification 尺寸規格

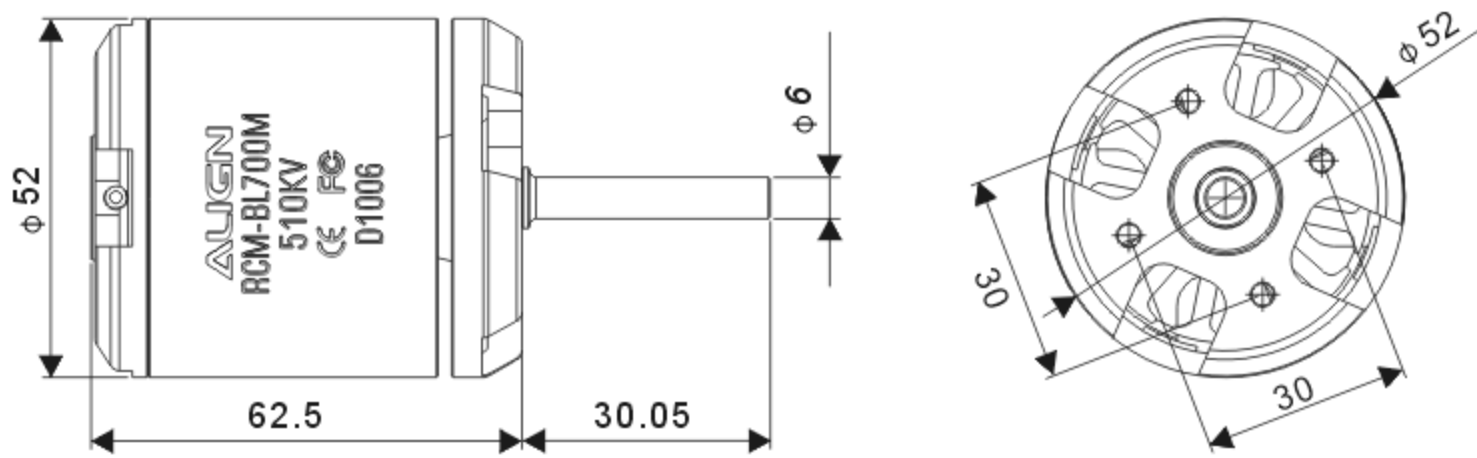

<b>KV</b>	KV值	510KV(RPM/V)	<b>Input voltage</b>	輸入電壓	DC 11.1~50.4V
<b>Stator Arms</b>	矽鋼片槽數	12	<b>Magnet Poles</b>	磁鐵極數	10
<b>Max continuous current</b>	最大持續電流	90A	<b>Max instantaneous current</b>	最大瞬間電流	150A(5sec)
<b>Max continuous power</b>	最大持續功率	4000W	<b>Max instantaneous power</b>	最大瞬間功率	6600W(5sec)
<b>Dimension</b>	尺寸	Shaft 6x52x62.5mm	<b>Weight</b>	重量	Approx. 460g

### Illustration 接線示意圖



The motor rotates in different direction with different brand ESCs. If the wrong rotating direction happens, please switch any two cables to make the motor rotates in right direction.

由於各品牌電子變速器的馬達啟動轉向不盡相同，若發生轉向錯誤時，請將馬達與電子變速器的接線任兩條對調即可。

## 16.SUGGESTIONS FOR ESC SETTING ESC 無刷調速器設定建議說明

ALIGN

**Suggested to use 12S Lipo HV (High Voltage) 80 Amp or higher ESC for T-REX 700E. Such as CASTLE ICE HV 80 ESC and KONTRONIK JIVE 80+HV. Suggested the maxium pitch: not exceed 13 degree. Under this circumstance will have a stable 3D flights and avoid the ESC overloading protect activate. Setting the pitch as 13~14 degree doesn't really enhance the efficiency but increasing current, temperature, and shorten the flight time.**

**If you want to set the maxium pitch to 13~14 degree, suggested to use CASTLE HV 110, CASTLE ICE HV 125, KONTRONIK POWERJIVE 120+HV, and higher ESC to make sure it works property.**

T-REX 700E 建議使用規格12S Lipo HV (High Voltage) 80 Amp以上之ESC，使用如CASTLE ICE HV 80 ESC KONTRONIK JIVE 80+HV,建議最大螺距設定勿超過13度，此設定下即有相當不錯的3D飛行特性而且可避免ESC啟動過載保護；最大螺距設定13~14度對整體動力並不會有顯著的提升，反而會增大電流、提高溫升、縮短飛行時間，若要將最大螺距設定至13~14度時，建議使用如 CASTLE HV 110, CASTLE ICE HV 125, KONTRONIK POWERJIVE 120+HV 以上之ESC，確保ESC正常工作

★ **For CASTLE ICE HV 80 series and higher ESC, please set with choice no. 2:Set current Limiting on "Insensitive", suitable for helicopter mode**

★ CASTLE ICE HV 80 系列以上ESC，請將程式設定第二項: Current Limiting 設定在 "Insensitive" 直昇機模式建議選項。

★ **For KONTRONIK JIVE 80+HV series and higher ESC, please set with Mode 10 "KSA Mode." If set as "Mode 4," the overloading protection may activate when pitch setting is bigger than 12 degree.**

★ KONTRONIK JIVE 80+HV 系列以上ESC,請將程式設定"Mode 10"KSA Mode，若設定於"Mode 4"，當Pitch 設定大於12度時可能會啟動過載保護。

**When choosing the ESC without build in BEC, you will need to external BEC (RCE-B6X) and 7.4V Lipo battery.**

選用無內建BEC的ESC時,須另外搭配外接式BEC (RCE-B6X)與7.4V Lipo電池

**Step1 步驟1**

**Turn on Transmitter, and then receiver power.**  
先開啓遙控器電源，再開啓接收器電源。

**Step2 步驟2**

**3G Flybarless system will go through initialization process, as indicated by flashing of all LED's. Do not move the helicopter or transmitter sticks until initialization process completes.**

此時3G Flybarless控制器指示燈STATUS及DIR~A.REV會閃動，請勿移動直昇機與撥動搖桿，以利陀螺儀感應器進入初始化程序。

**Step3 步驟3**

**The completion of initialization process is indicated by the rapid up and down motion of swashplate 3 times while remaining level. Should the swashplate jumps up and down at a tilted position, the flybarless system initial setup need to be performed again. (Refer to page 23 Flybarless system initial setup)**

**The pitch of helicopter will remain locked until successful initialization. If the initialization process is unable to complete, with STATUS LED blinking red, Re-check all connections, and perform another reboot with helicopter remain stationary.**

**Following successful initialization process, green STATUS LED indicates rudder is in heading lock mode, while red LED indicates normal non-heading mode. (Refer to page 29 Gain Adjustment)**

如左圖示，初始化完成後，十字盤會保持水平上下小幅跳動三次，表示完成開機程序；如十字盤為傾斜跳動三次，則表示設定錯誤，須進入無平衡翼系統重新設定。（參考第23頁 無平衡翼系統設定）

完成開機前直昇機螺距被固定無法動作，如果一直無法完成開機程序STATUS紅燈閃爍，請檢查開機時直昇機是否靜止或感應器訊號線未接妥，確認後重新開機。正常開機後，STATUS亮綠燈表示尾舵為鎖定模式，亮紅燈為非鎖定模式。（請參考第29頁 感度調整）

Green = rudder in heading lock mode  
Red = rudder in normal mode

綠燈為尾舵鎖定模式  
紅燈為尾舵非鎖定模式

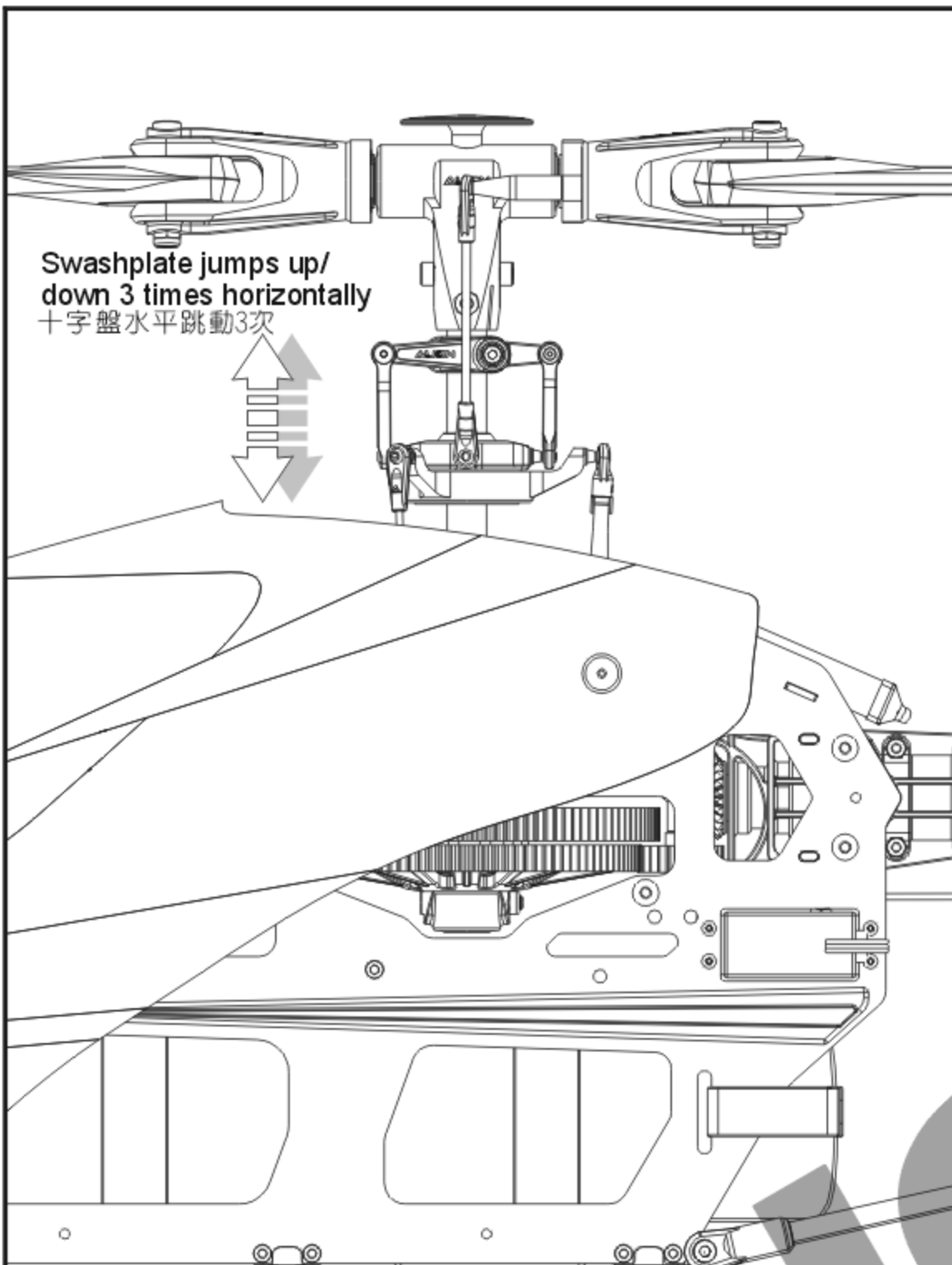
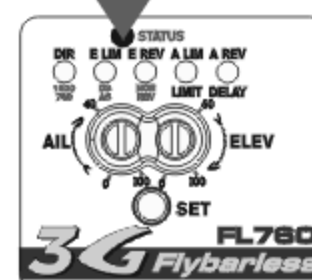

**Step4 步驟4**

**Tilt the helicopter forward and swashplate should tilt back to compensate. If reversed, perform the flybarless initial setup again and adjust the elevator reverse setting (Refer to page 25 E:REV setup)**

將直昇機往前傾，陀螺儀應將十字盤向後修正，如果反向，重新進入Flybarless設定模式設定升降舵陀螺儀修正方向。（請參考第25頁 E:REV升降舵陀螺儀正反向設定模式）

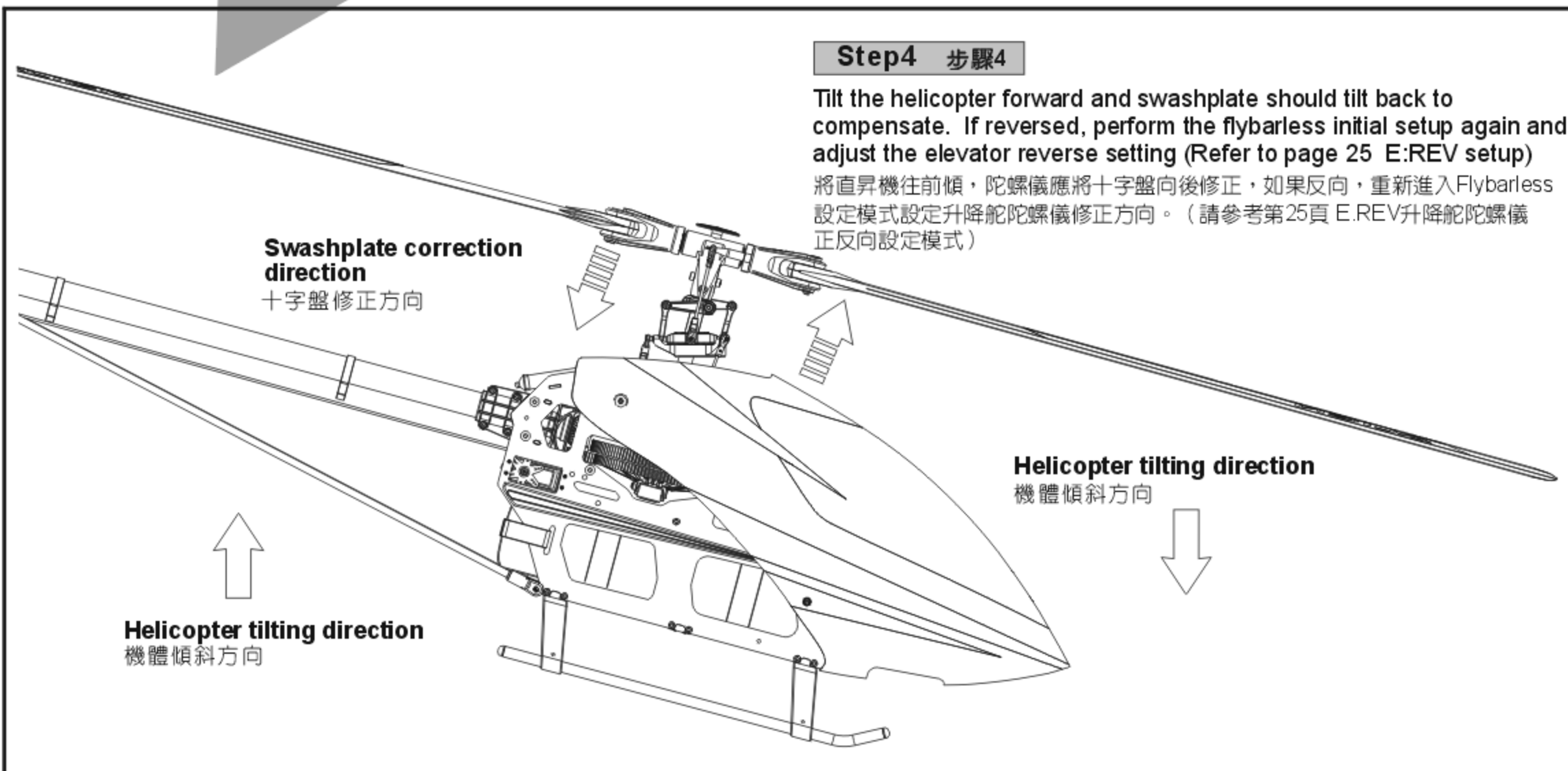



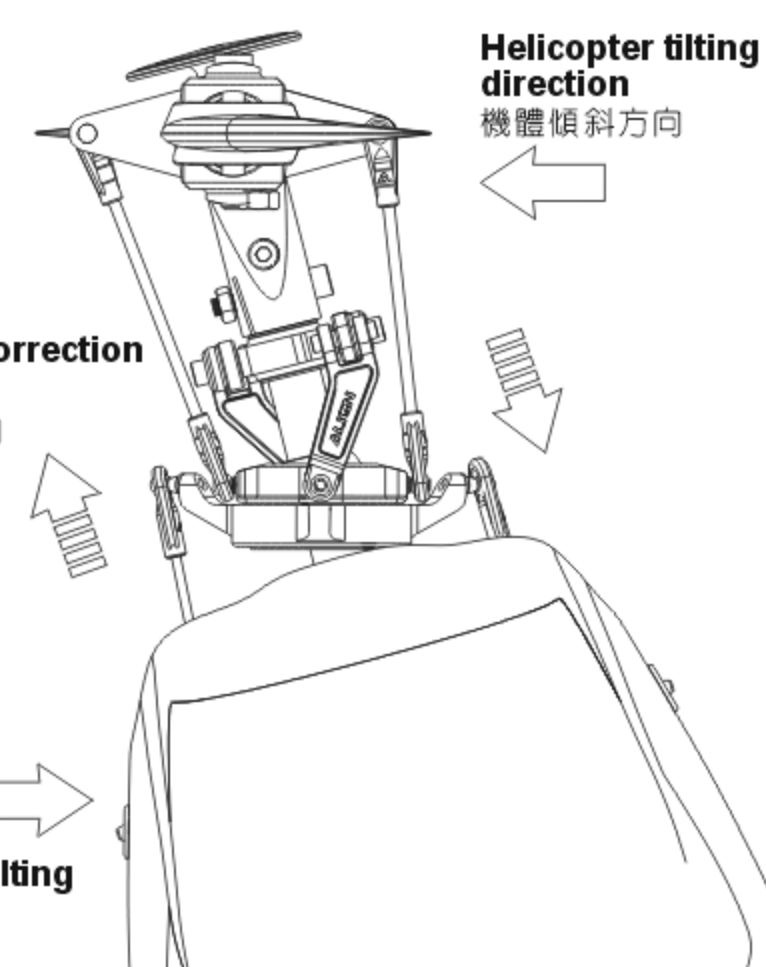

**Swashplate correction direction**  
十字盤修正方向

**Helicopter tilting direction**  
機體傾斜方向

**Helicopter tilting direction**  
機體傾斜方向

**Step5 步驟5**  
Tilt the helicopter to the right and swashplate should tilt left to compensate. If reversed, perform the flybarless initial setup again and adjust the aileron reverse setting (Refer to page26 A:REV setup) 將直昇機往右傾，陀螺儀應將十字盤向左修正，如果反向，重新進入Flybarless設定模式設定副翼陀螺儀修正方向。（如左圖所示：參考第26頁 A:REV副翼陀螺儀正反向設定模式）

**Step6 步驟6**  
With throttle stick all the way up (and down), and cyclic stick all the way left/right and up/down, check for any binding on the swashplate. If binding occurs, perform the flybarless initial setup again and adjust the endpoint limits. 將油門搖桿推到最高及最低，並將搖桿左右及前後推到底，十字盤動作是否流暢，如果不是必須重新進入 Flybarless設定模式裏設定行程。

**Step7 步驟7**  
Check the center of gravity (CG) and adjust component placement until CG point is right on the main shaft of the helicopter. 檢視直升機體重心是否適當請先調整直昇機體重心位置至主軸中心線下方位置。

**Step8 步驟8**  
With all above steps checked, restart the system and begin flight test. 確定所有功能正常，重新開機，完成開機程序後進入飛行測試。

**HELICOPTER CG CHECK PROCEDURE 直昇機機體重心檢視方式**

After installed the battery, hold the helicopter as shown. Once the helicopter stops rotating, the helicopter's CG can be seen at where the head is pointing relative to the main shaft.

電池固定後，將直昇機如圖示舉起，等待直昇機停止轉動後檢視機頭方向，正確重心應落在機身（主軸附近）位置。

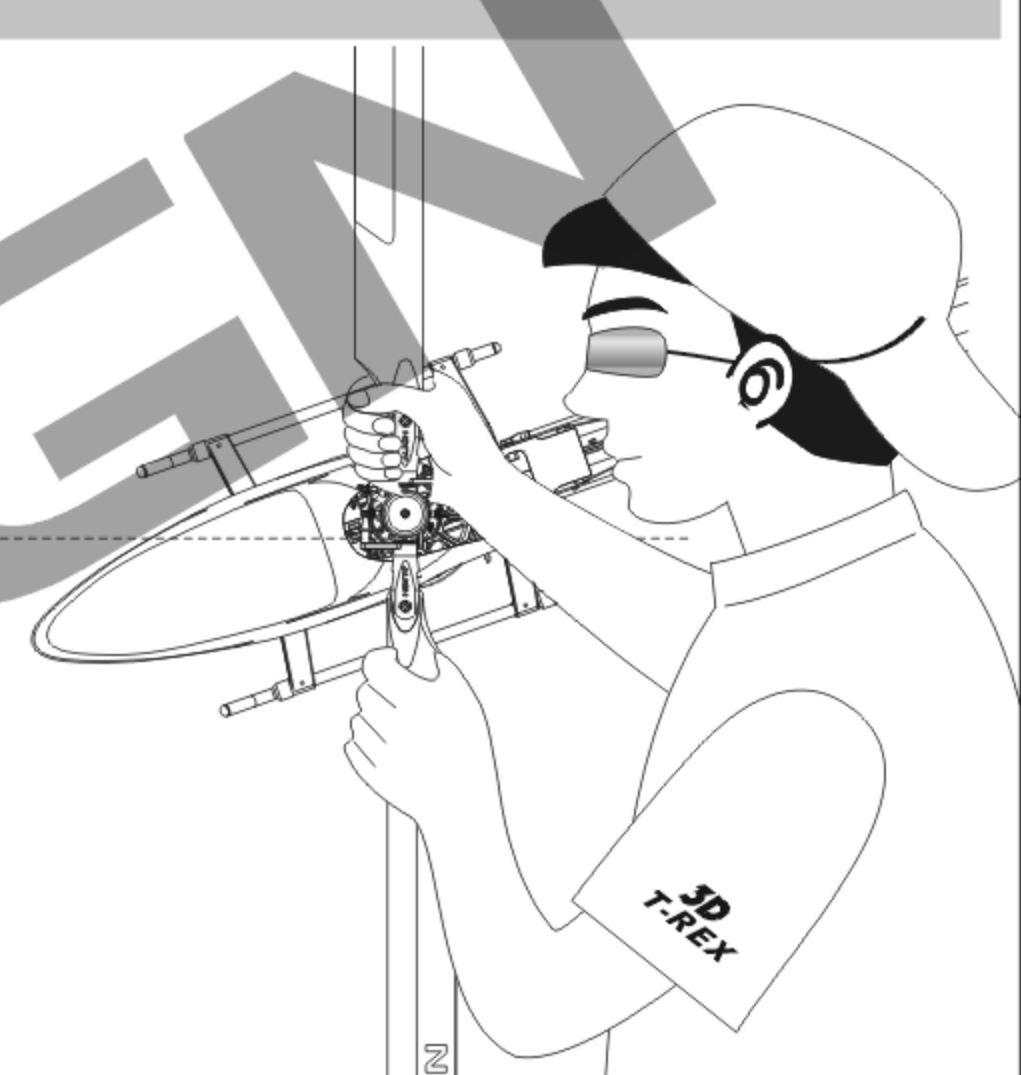

**Helicopter head should be level with main shaft, or slightly lower than the main shaft to ensure the center of gravity is maintained during flight.**  
機頭應與主軸中心線水平，或機頭略低主軸中心線，確保飛行重心。



**18.FLIGHT ADJUSTMENT AND SETTING 飛行動作調整與設定** **ALIGN**

**Please practice simulation flight before real flying 飛行前請事先熟練電腦模擬飛行**

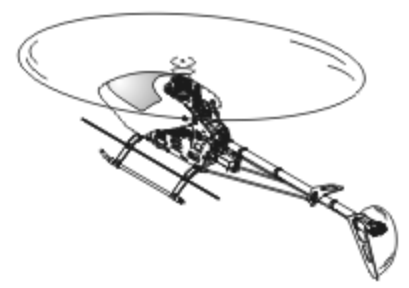





A safe and effective practice method is to use the transmitter flying on the computer through simulator software sold on the market. Do a simulation flight until you familiarize your fingers with the movements of the rudders, and keep practicing until the fingers move naturally.

1. Place the helicopter in a clear open field ( Make sure the power OFF ) and the tail of helicopter point to yourself.
2. Practice to operate the throttle stick (as below illustration) and repeat practicing "Throttle high/low", "Aileron left/right", "Rudder left/right", and "Elevator up/down".
3. The simulation flight practice is very important, please keep practicing until the fingers move naturally when you hear operation orders being call out.

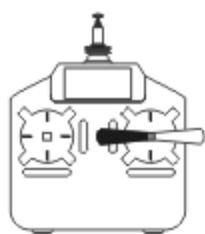
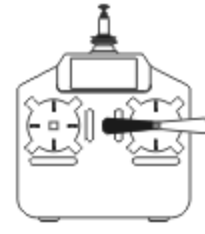
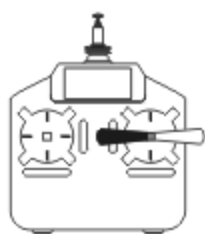
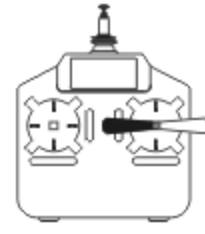
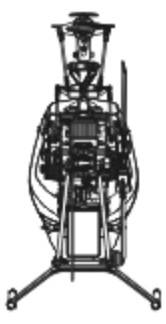
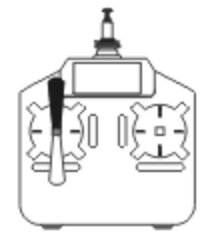
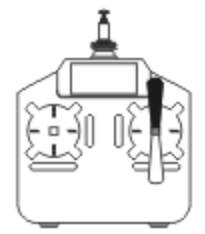
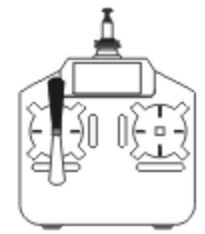
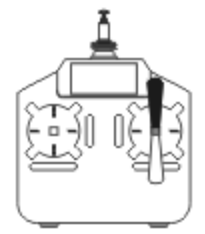
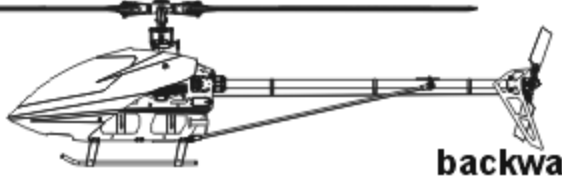
在還沒瞭解直昇機各動作的操控方式前，嚴禁實機飛行，請先進行電腦模擬飛行的練習，一種最有效、最安全的練習方式，就是透過市面販售的模擬軟體，以遙控器在電腦上模擬飛行，熟悉各種方向的操控，並不斷的重複，直到手指可熟練的控制各個動作及方向。

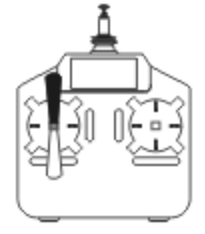
1. 將直昇機放在空曠的地方(確認電源為關閉)，並將直昇機的機尾對準自己。
2. 練習操作遙控器的各搖桿(各動作的操作方式如下圖)，並反覆練習油門高/低、副翼左/右、升降舵前/後及方向舵左/右操作方式。
3. 模擬飛行的練習相當重要，請重複練習直到不需思索，手指能自然隨著喊出的指令移動控制。

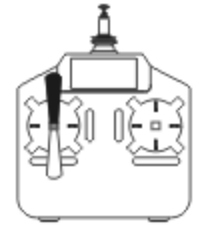
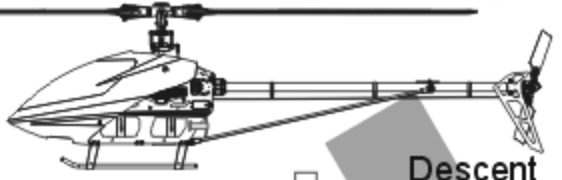
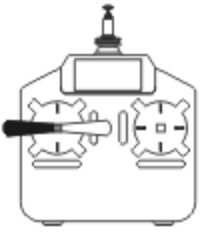
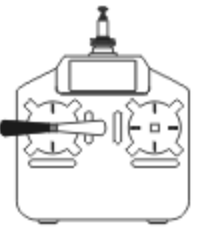
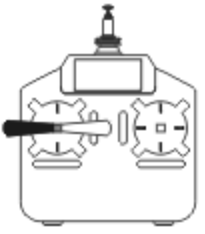
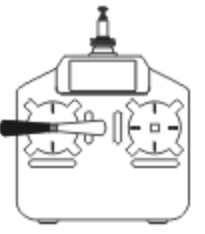
Mode 1	Mode 2	Illustration 圖示
 <b>Aileron 副翼</b> 	 <b>Aileron 副翼</b> 	 <b>Move left</b> 左移 ← <b>Rotate left</b> 左翻 ↶  <b>Move right</b> 右移 → <b>Rotate right</b> 右翻 ↷
 <b>Elevator 升降/前後</b> 	 <b>Elevator 升降/前後</b> 	 <b>Fly forward</b> 前進 ← <b>Forward rotate</b> 前翻 ↶  <b>Fly backward</b> 後退 → <b>backward rotate</b> 後翻 ↷
 <b>Throttle 油門</b> 	 <b>Throttle 油門</b> 	 <b>Ascent</b> 上升 ↑ <b>Descent</b> 下降 ↓
 <b>Rudder 方向</b> 	 <b>Rudder 方向</b> 	 <b>Turn right</b> 右旋 ↷ <b>Turn left</b> 左旋 ↶

### Flight adjustment and notice 飛行調整與注意



- ⊙ Check if the screws are firmly tightened.
- ⊙ Check if the transmitter and receivers are fully charged.
- ⊙ 再次確認→螺絲是否鎖固?
- ⊙ 發射器和接收器電池是否足夠。



If there are other radio control aircraft at the field, make sure to check their frequencies and tell them what frequency you are using. Frequency interference can cause your model, or other models to crash and increase the risk of danger.  
假使飛行場有其他遙控飛機，請確認他們的頻率，並告知他們你正在使用的頻率，相同的頻率會造成干擾導致失控和大大地增加風險。

### ★When arriving at the flying field.

★當抵達飛行場

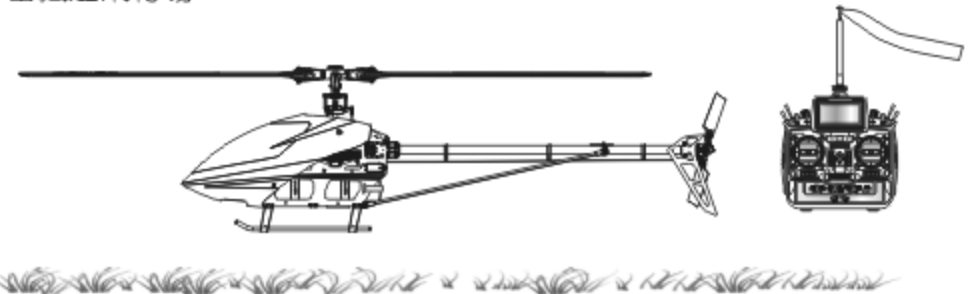

### STARTING AND STOPPING THE MOTOR 啟動和停止馬達



**First check to make sure no one else is operating on the same frequency. Then place the throttle stick at lowest position and turn on the transmitter.**

首先確認附近沒有其他相同頻率的使用，然後打開發射器將油門搖桿推到低點。

### ★Check the movement.

★動作確認



**ON! Step1**  
First turn on the transmitter.  
先開啟發射器



**Check if the throttle stick is set at the lowest position.**  
確認油門搖桿是在最低的位置。

Mode 1 Mode 2

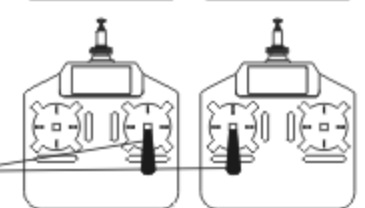

- ⊙ Are the rudders moving according to the controls?
- ⊙ Follow the transmitter's instruction manual to do a range test.
- ⊙ 方向舵是否隨著控制方向移動?
- ⊙ 根據發射器說明書進行距離測試。



**ON! Step2**  
Connect to the helicopter power  
接上直昇機電源

**OFF! Step3**  
Reverse the above orders to turn off.  
關閉電源時請依上述操作動作反執行。

**This procedure is best performed on soft surfaces such as grass. The use of rubber skid stopper is recommended on hard surface to prevent vibration feedback from the ground to flybarless sensors, resulting in over-corrections.**

將直升機置於柔軟地面上，建議硬地起飛腳架裝上避震墊圈。避免升空前腳架與過硬的地面震動太大反饋至機身上的無平衡翼感應器，影響無平衡翼系統升空前過度修正。

**Rubber skid stoppers installed**  
裝上避震墊圈

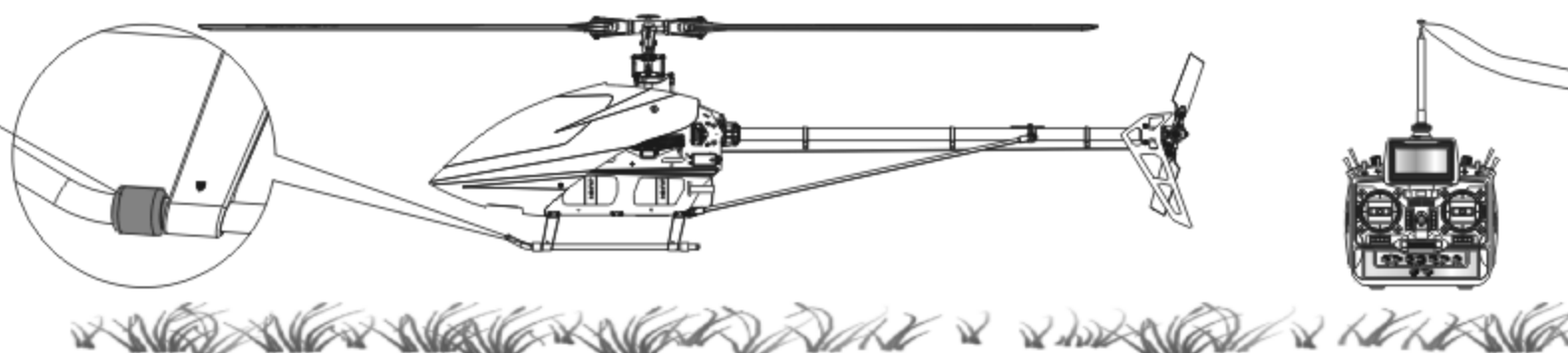

**If swashplate should tilt prior to lift off, do not try to manually trim the swashplate level. This is due to vibration feedback to the sensor, and will disappear once helicopter lifts off the ground. If manual trim is applied, helicopter will tilt immediately after liftoff.**  
直昇機離地前，十字盤可能因感應器受震動的反饋，使十字盤有傾斜的情形，此時請勿刻意將十字盤修正為水平狀態，此現象只要離地升空時立即解除，可平穩升空；若刻意將十字盤修正為水平時，反而會造成感應器過度修正，一離地即偏往修正方向的危險。

### Main rotor adjustments 主旋翼雙槳平衡調整

1. Before adjusting, apply a red piece of tape on one blade, or paint a red stripe with a marker or paint to identify on blade.
2. Raise the throttle stick slowly and stop just before the helicopter lifts-off ground. Look at the spinning blades from the side of the helicopter.
3. Look at the path of the rotor carefully. If the two blades rotate in the same path, it does not need to adjustment. If one blade is higher or lower than the other blade, adjust the tracking immediately.

1. 調整前先在其中一支主旋翼的翼端，貼上有顏色的貼紙或畫上顏色記號，方便雙槳調整辨識。
2. 慢慢的推起油門搖桿到高點並且停止，在飛機離開地面前，從飛機側邊觀察主旋翼轉動。
3. 仔細觀察旋翼軌跡(假如兩支旋翼移動都是相同軌跡，則不需要調整;可是如果一支旋翼較高或較低產生“雙槳”的情形時，則必須立刻調整軌跡)。

**A. When rotating, the blade with higher path means the pitch too big. Please shorten pitch linkage rod (A) for regular trim.**  
**B. When rotating, the blade with lower path means the pitch too small. Please lengthen pitch linkage rod (A) for regular trim.**

- A. 旋翼轉動時較高軌跡的主旋翼表示螺距(PITCH)過大，請調短連桿(A)修正。
- B. 旋翼轉動時較低軌跡的主旋翼表示螺距(PITCH)過小，請調長連桿(A)修正。



**Tracking adjustment is very dangerous, so please keep away from the helicopter at a distance of at least 10m.**  
調整軌跡非常危險，請於距離飛機最少10公尺的距離。

**Incorrect tracking may cause vibrations. Please repeat adjusting the tracking to make sure the rotor is correctly aligned. After tracking adjustment, please check the pitch angle is approx. +5~6° when hovering.**  
不正確的旋翼軌跡會導致震動，請不斷重複調整軌跡，使旋翼軌跡精準正確。在調整軌跡後，確認一下Pitch角度在停旋時應為大約+5~6°。



### FLIGHT ADJUSTMENT AND NOTICE 飛行調整與注意

- ⊙ During the operation of the helicopter, please stand approximately 10m diagonally behind the helicopter.
- ⊙ 飛行時，請站在直昇機後方最少10公尺。



- ⊙ Make sure that no one or obstructions in the vicinity.
- ⊙ For flying safety, please carefully check if every movement and directions are correct when hovering.
- ⊙ 確認鄰近地區沒有人和障礙物。
- ⊙ 為了飛行安全，您必須先確認停懸時各項操控動作是否正常。

**WARNING 警告 Do not attempt until you have some experiences with the operation of helicopter.**  
嚴禁無熟練操控飛行經驗者操控飛行。

### STEP 1 THROTTLE CONTROL PRACTICE 油門控制練習

- ⊙ When the helicopter begins to lift-off the ground, slowly reduce the throttle to bring the helicopter back down. Keep practicing this action until you control the throttle smoothly.
- ⊙ 當直昇機開始離地時，慢慢降低油門將飛機降下。持續練習飛機從地面上升和下降直到你覺得油門控制很順。

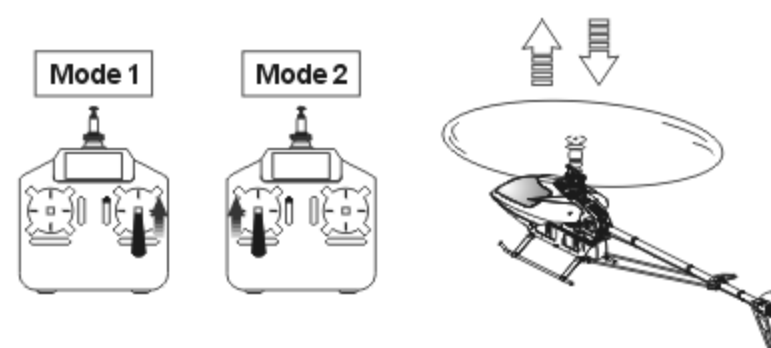

## STEP 2 AILERON AND ELEVATOR CONTROL PRACTICE 副翼和升降控制練習

1. Raise the throttle stick slowly.
2. Move the helicopter in any direction back, forward, left and right, slowly move the aileron and elevator sticks in the opposite direction to fly back to its original position.

1. 慢慢升起油門搖桿。
2. 使直昇機依指示：移動向後/向前/向左/向右，慢慢的反向 移動副翼和升降搖桿 並將直昇機開回到原來位置。

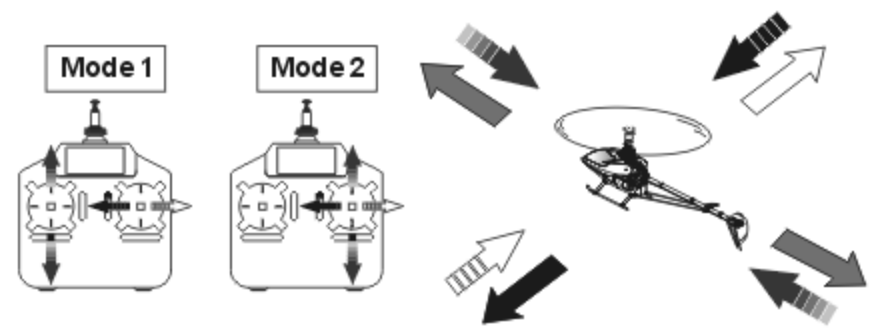

- ⊙ If the nose of the helicopter moves, please lower the throttle stick and land the helicopter. Then move your position diagonally behind the helicopter 10m and continue practicing.
- ⊙ If the helicopter flies too far away from you, please land the helicopter and move your position behind 10m and continue practicing.

- ⊙ 當直昇機機頭偏移時，請降低油門並且降落，然後移動自己的位置到直昇機的正後方10公尺再繼續練習。
- ⊙ 假如直昇機飛離你太遠，請先降落直昇機，並到直昇機後10公尺再繼續練習。

## STEP 3 RUDDER CONTROL PRACTICING 方向舵操作練習

1. Slowly raise the throttle stick.
2. Move the nose of the helicopter to right or left, and then slowly move the rudder stick in the opposite direction to fly back to its original position.

1. 慢慢升起油門搖桿。
2. 將直昇機機頭移動左或右，然後慢慢反向移動方向舵搖桿並將直昇機飛回原本位置。

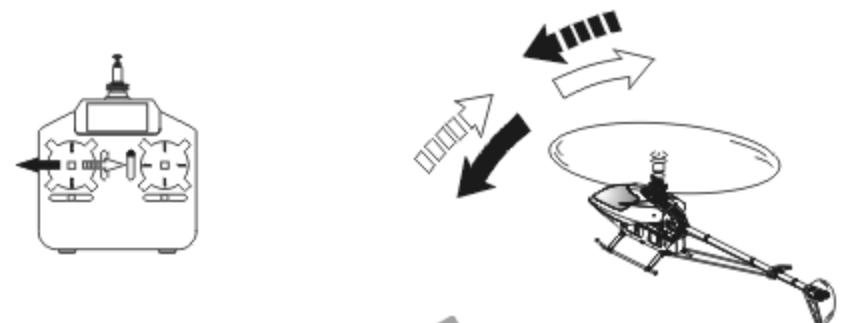

## STEP 4

After you are familiar with all actions from Step1 to 3, draw a circle on the ground and practice within the circle to increase your accuracy.

- ⊙ You can draw a smaller circle when you get more familiar with the actions.

當你覺得 step1~3 動作熟悉了，在地上畫圈圈並在這個圈圈的範圍內練習飛行，以增加你操控的準確度。

- ⊙ 當你更加習慣操作動作，你可以畫更小的圈圈。

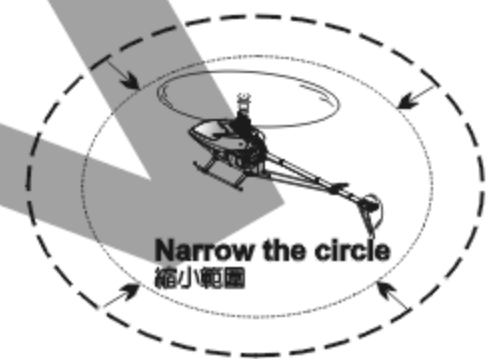

## STEP 5 DIRECTION CHANGE AND HOVERING PRACTICE 改變直昇機方向和練習停懸

After you are familiar with Step1 to 4, stand at side of the helicopter and continue practicing Step1 to 4. Then repeat the Step1 to 4 by standing right in front of the helicopter.

當你覺得step1~4動作熟悉了，站在面對直昇機側邊並繼續練習step1~4。之後，站在直昇機機頭右邊重複步驟練習。

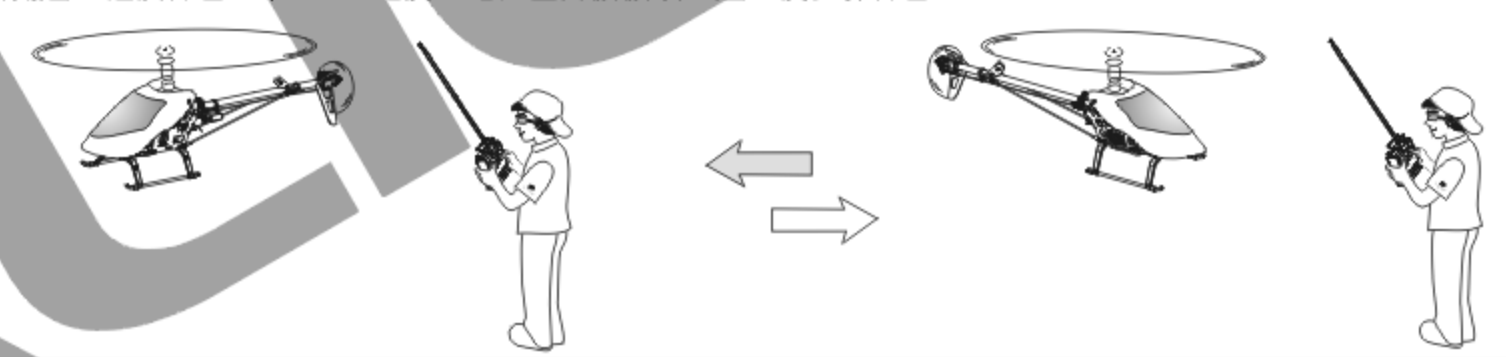

## ADJUSTMENT OF EACH TRIM 飛行動作微調

Slowly raise the throttle stick and just as the helicopter lift-off the ground, you can use the trim to correct the action if the helicopter leans in a different direction.

慢慢升起油門搖桿，當直昇機剛剛離開地面時，若直昇機傾向不同方向，可使用微調修正動作。

### 1. Adjustment of rudder trim

Just before the helicopter lift-off, the nose lean left/right...

When leans right, adjust the trim to left side.

When leans left, adjust the trim to right side.

調整方向舵微調

在直昇機正要起飛時，機頭朝左/右方向偏移...

向右偏移時，微調向左調整。

向左偏移時，微調向右調整。

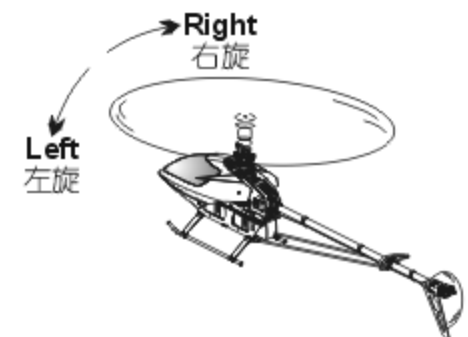
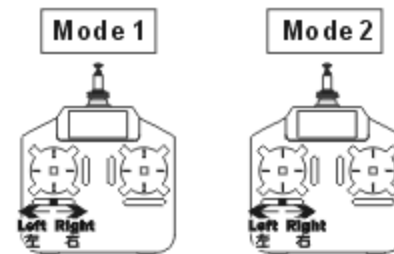

### 2. Adjustment of elevator trim

Just before the helicopter lift-off, the nose lean forward/backward...

When leans forward, adjust the trim down.

When leans backward, adjust the trim up.

調整升降舵微調

在直昇機正要起飛時，機頭朝前/後方向偏移...

向前偏移時，微調向下調整。

向後偏移時，微調向上調整。

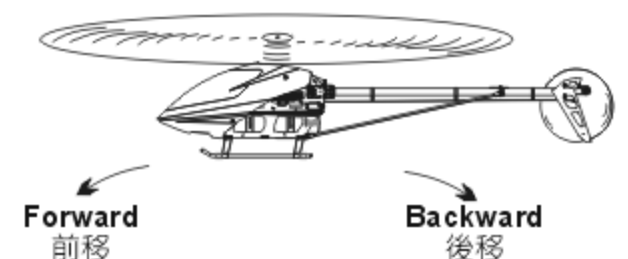
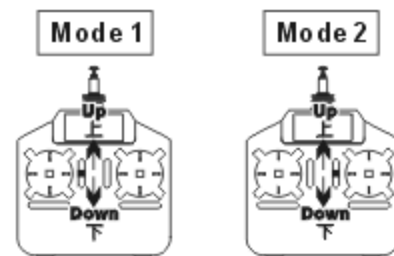

### 3. Adjustment of Aileron trim

Just before the helicopter lift-off, the body lean left/right...

When leans right, adjust the trim to left side.

When leans left, adjust the trim to right side.

調整副翼微調

在直昇機正要起飛時，機身朝左/右方向偏移...

向右偏移時，微調向左調整。

向左偏移時，微調向右調整。

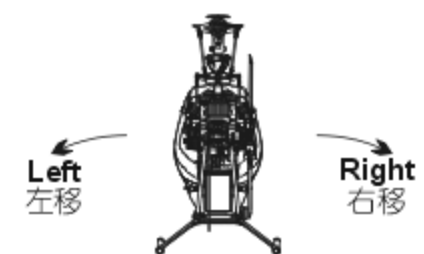
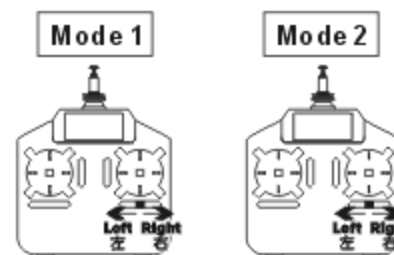

With the helicopter hovering, observe for any rapid left/right or forward/aft oscillations. If forward/aft oscillation is observed, land the helicopter, turn the ELE gain dial counterclockwise gradually, and test again. Do this until oscillation disappears.

先將直昇機以停懸飛行，觀察直昇機左右及前後是否有不正常快速抖動現象，如果前後有抖動情形，則逆時針調降升降舵感度調整旋鈕，以減少陀螺儀前後修正感度。

Set the dial to 12 o'clock position as starting point

建議初次飛行設於12點鐘方向

Elevator gain adjustment dial  
升降舵感度調整旋鈕

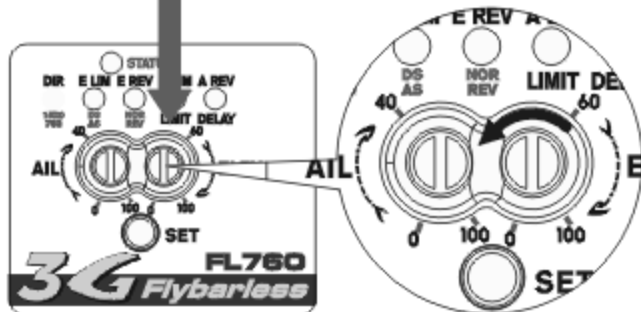

Decrease ELE gain  
調降ELE感度



Forward/back oscillation  
前後晃動



If left/right oscillation is observed, land the helicopter, turn the AIL gain dial counterclockwise gradually, and test again. Do this until oscillation disappears.

如果為左右抖動，逆時針調降副翼感度調整旋鈕，以減少陀螺儀左右修正感度。

Set the dial to 12 o'clock position as starting point

建議初次飛行設於12點鐘方向

Aileron gain adjustment dial  
副翼感度調整旋鈕

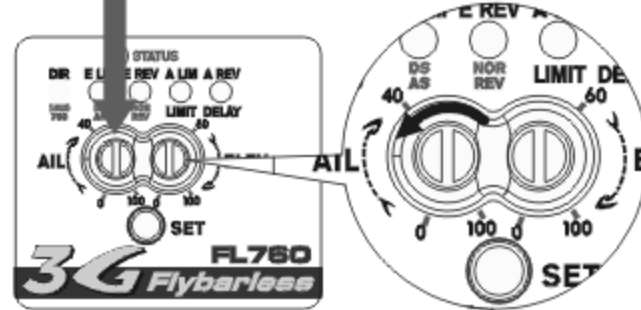

Decrease AIL gain  
調降AIL感度

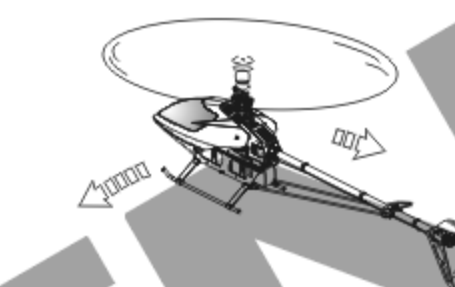

Left/right oscillation  
左右晃動



FORWARD STRAIGHT LINE FLIGHT 前進直線航道飛行

Put the helicopter into fast forward flight from hovering. If similar oscillation is observed, reduce the elevator gyro gain. If the helicopter pitches up, or responds slowly, increase the elevator gyro gain. Repeat test until the oscillation is eliminated. Similar method is used for aileron gyro gain. After gyro gain adjustments are completed, the helicopter cyclic rate can be tuned using transmitter's swash AIL and ELE mixing ratio. Higher the percentage, faster the roll/flip rate. Exponential can also be added on the transmitter to soften the sensitivity for stable hover.

停懸完後可快速前進飛行，同樣的如果有不正常抖動時，請將升降舵感度調小，飛行時如果有機頭向上仰起或反應緩慢現象時，請將感度調大，重複測試將感度調整至最理想值，同樣方式可調整副翼感度旋鈕。調整完陀螺儀感度，可依據飛行習慣調整Swash AIL及ELE比率，比率調整越大，前後及左右滾轉速度越快，使用者也可依據個人經驗調整舵面EXP以增加停旋穩定性。完成所有調整後，就可享受Flybarless所提供低速飛行的穩定性及高速時的靈活性。



Forward Flight  
前進飛行



Using Futaba 12ZH transmitter as an example 以Futaba 12ZH遙控器為例

	With emphasis on stability 穩定特性	With emphasis on agility 靈活特性
Main blade pitch Settings(Collective Pitch Settings) 主旋翼螺距設定 (集體螺距設定)	Main blade pitch : 10°~12° 主旋翼螺距 : 10°~12° swash pitch : 38%~44%	Main blade pitch : 12°~14° 主旋翼螺距 : 12°~14° swash pitch : 44%~50%
Cyclic pitch settings (Adjust while in DIR mode using AIL/ELE swash AFR) 循環螺距設定 (須在DIR模式下設定)	Cyclic Pitch 10° 循環螺距10° swash Aileron : 65% Elevator : 65%	Cyclic Pitch 12° 循環螺距12° swash Aileron : 75% Elevator : 75%
Aileron and Elevator swashplate mixing ratio settings 副翼與升降舵滾轉速率設定	swash Aileron : ≤ 65% Elevator : ≤ 65%	swash Aileron : ≤ 75% Elevator : ≤ 75%
Aileron and Elevator gyro gain settings 副翼與升降舵鎖定感度設定	12 o'clock direction(50%) 12點鐘方向(50%)	11 o'clock direction(40%) 11點鐘方向(40%)



While in DIR setup mode, the transmitter's CCPM swash mixing values for aileron and elevator represent CYCLIC pitch values. These values affect the cyclic roll rates on the aileron and elevator in flying condition. Higher values translate to faster cyclic roll rates. If cyclic roll rate is not improved with increased swash mixing values, this is due to insufficient cyclic pitch. When this happens, cyclic pitch can be increased through the flybarless setup procedure. Maximum cyclic pitch should be limited at 14 degrees.

遙控器上的CCPM十字盤混控SWASH於"DIR"模式設定循環螺距時，Aileron與Elevator比率值的大小代表循環螺距角度的大小，比率愈高循環螺距的角度愈大；而在飛行模式下Aileron與Elevator比率值的大小代表滾轉速率的大小，比率愈高滾轉速率愈快，但若比率調高仍無法提升滾轉速率時表示循環螺距不足，請進入無平衡翼系統設定模式，將循環螺距加大，但以不超過14°為限。

	Problem 狀況	Cause 原因	Solution 對策
<b>Blade Tracking</b> 雙槳平衡	<b>Tracking is Off</b> 雙槳	<b>Pitch linkage rods are not even length</b> PITCH連桿長度調整不平均	<b>Adjust length of pitch linkage rods (A)</b> 調整連桿(A)長度
<b>Hover</b> 停懸	<b>Head speed too low</b> 主旋翼轉速偏低	<b>Excessive pitch</b> 主旋翼的PITCH偏高	<b>Adjust pitch linkage rods (A) to reduce pitch by 4 to 5 degrees. Hovering head speed should be around 1700~1800RPM.</b> 調整連桿(A)調低Pitch約+4~5度 (停懸時主旋翼需為約1700~1800RPM)
		<b>Hovering throttle curve is too low</b> 停懸點油門曲線過低	<b>Increase throttle curve at hovering point on transmitter (around 60%)</b> 調高停懸點油門曲線(約60%)
	<b>Head speed too high</b> 主旋翼轉速偏高	<b>Not enough pitch</b> 主旋翼的PITCH偏低	<b>Adjust pitch linkage rods (A) to increase pitch by 4 to 5 degrees. Hovering head speed should be around 1700~1800RPM.</b> 調整連桿(A)調高Pitch約+4~5度 (停懸時主旋翼需為約1700~1800RPM)
		<b>Hovering throttle curve is too high</b> 停懸點油門曲線過高	<b>Decrease throttle curve at hovering point on transmitter (around 60%)</b> 調低停懸點油門曲線(約60%)
<b>Rudder Response</b> 尾舵反應	<b>Drifting of tail occurs during hovering, or delay of rudder response when centering rudder stick.</b> 停懸時尾翼向某一邊偏移，或撥動方向舵並回復到中立點時，尾翼產生延遲，無法停頓在所控制位置上。	<b>Rudder neutral point improperly set</b> 尾中立點設定不當	<b>Reset rudder neutral point</b> 重設尾中立點
	<b>Tail oscillates (hunting, or wags) at hover or full throttle</b> 停懸或全油門時尾翼左右來回搖擺。	<b>Rudder gyro gain too low</b> 尾舵陀螺儀感度偏低	<b>Increase rudder gyro gain</b> 增加尾舵陀螺儀感度
		<b>Rudder gyro gain too high</b> 尾舵陀螺儀感度偏高	<b>Reduce rudder gyro gain</b> 降低尾舵陀螺儀感度
<b>Oscillation during flight</b> 飛行抖動	<b>Forward/aft oscillation when elevator is applied</b> 升降舵打舵動作時，機體前後抖動	<b>Elevator gyro gain too high.</b> 升降舵陀螺感度偏高，產生追蹤現象	<b>Turn the ELE gain dial on control box counterclockwise, 10 degrees at a time until oscillation is eliminated.</b> 逆時針調整控制器上的升降舵感度調整旋鈕，以每次調整約10度的方式，調整至適當位置
	<b>Helicopter front bobbles (nods) during forward flight.</b> 直線飛行時，機頭點頭		<b>Worn servo, or slack in control links</b> 伺服器老化，控制結構有虛位
	<b>Left/right oscillation when aileron is applied</b> 副翼打舵動作時，機體左右抖動	<b>Aileron gyro gain too high</b> 副翼陀螺感度偏高，產生追蹤現象	<b>Turn the AIL gain dial on control box counterclockwise, 10 degrees at a time until oscillation is eliminated.</b> 逆時針調整控制器上的副翼感度調整旋鈕，以每次調整約10度的方式，調整至適當位置
	<b>Elevator input causes helicopter to drift</b> 升降舵動作飄移		<b>Worn servo, or slack in control links</b> 伺服器老化，控制結構有虛位
<b>Drifting during flight</b> 飛行飄移	<b>Helicopter pitches up during forward flight</b> 直線飛行機頭上揚	<b>Elevator gyro gain too low</b> 升降舵陀螺感度偏低	<b>Turn the ELE gain dial on control box clockwise, 10 degrees at a time until drifting is eliminated.</b> 順時針調整控制器上的升降舵感度調整旋鈕，以每次調整約10度的方式，調整至適當位置
	<b>Aileron input causes helicopter to drift</b> 副翼動作飄移	<b>Aileron gyro gain too low</b> 副翼陀螺感度偏低	<b>Turn the AIL gain dial on control box clockwise, 10 degrees at a time until drifting is eliminated.</b> 順時針調整控制器上的升降舵感度調整旋鈕，以每次調整約10度的方式，調整至適當位置
<b>Control Response</b> 動作反應	<b>Slow Forward/Aft/Left/Right input response</b> 前後左右飛行動作反應偏慢	<b>Roll rate too low</b> 滾轉速率偏低	<b>Increase the swashplate AFR in transmitter</b> 調整遙控器內Swash AFR值，提高滾轉速率
		<b>Roll rate still slow after swash afr adjustment, cyclic pitch too low</b> 已經調整滾轉速率仍然滾動偏慢，循環角度偏低	<b>Go back through the DIR setup procedure and increase the cyclic pitch.</b> 重新進入DIR模式，設定較大的循環螺距角度
	<b>Sensitive Forward/Aft/Left/Right input response</b> 前後左右飛行動作反應偏快	<b>Roll rate too high</b> 滾轉速率偏快	<b>Decrease the swashplate AFR in transmitter</b> 調整遙控器內Swash AFR值，降低滾轉速率
		<b>Roll rate still too fast after swash afr adjustment, cyclic pitch too high</b> 已經調整滾轉速率仍然滾動偏快，循環角度偏高	<b>Go back through the DIR setup procedure and decrease the cyclic pitch.</b> 重新進入DIR模式，設定較小的循環螺距角度

If above solution does not resolve your issues, please check with experienced pilots or contact your Align dealer.

※在做完以上調整後，仍然無法改善情況時，應立即停止飛行並向有經驗的飛手諮詢或連絡您的經銷商。

**Q&A 1** **Pitches up during fast forward flight.**  
 (1) Elevator gyro gain too low, increase the elevator gain by gradually turning the ELE dial clockwise.  
 (2) Elevator trim not centered. Check if helicopter is tilting backwards during hover.

快速飛行時直昇機機頭會上揚？

- (1) ELE感度不足，請稍微將ELE感度旋鈕順時針方向調高。
- (2) ELE中立點不對，請測試停懸時，直昇機中立點是否朝後。

**Q&A 2** **Insufficient gain during flight, but increasing gain results in oscillation.**  
 (1) Check and resolve possible mechanical vibration from helicopter.  
 (2) Use softer sensor mounting foam, or double up the stock sensor foam.  
 (3) Relocate the sensor to location less prone to vibration.

飛行時感度不足，將感度調高直昇機卻會抖動？

- (1) 檢查直昇機是否有異常震動，如果是請先修復機體。
- (2) 用材質較軟或兩片雙面膠泡棉固定三軸陀螺儀感應器。
- (3) 將感應器換裝於直昇機較不震動的位置。

**Q&A 3** **Drifting during 3D maneuvers.**  
 (1) Increase AIL and ELE gain by turning both dials clockwise.  
 (2) Check if cyclic servos are too slow (minimum 0.1sec / 60 degrees)

3D飛行時有飄移現象？

- (1) 將升降與副翼感度旋鈕順時針方向調高。
- (2) 檢查推動十字盤的伺服器是否過慢（建議選擇動作速度0.1sec/60度以內規格）。

**Q&A 4** **Unstable hover, control inputs are too sensitive.**  
 Decrease the aileron and elevator ATV (AFR) value on the transmitter. For CCPM machines, decrease swashplate mixing percentage on the transmitter. In addition, exponential can be added to aileron and elevator channels.

停懸時不穩定，有動作過靈敏現象？

可調低遙控器AIL及ELE的ATV (AFR) 值 (CCPM 模式，請調降Swash比率)，並增加EXP的設定，以提高停懸的穩定性。

**Q&A 5** **After increasing the ATV (AFR) of aileron and elevator, 3D roll rates are still not enough.**  
 Go back through the DIR setup procedure and use larger cyclic pitch.

已調高AIL及ELE的ATV (AFR)，但3D飛行的滾轉速率卻無法提高？

重新進入DIR模式，設定較大的循環螺距角度。

**Q&A 6** **Helicopter oscillates after fast forward flight or after tumbles.**  
 (1) Gradually reduce both AIL and ELE gain by turning them counterclockwise, 10 degrees at a time.  
 (2) Use harder head dampener.

直昇機高速飛行或滾轉後停止時，機身會有輕微抖動現象？

- (1) 逆時針調整控制器上的升降舵感度調整旋鈕，以每次調整約10度的方式，調整至適當位置。
- (2) 主旋翼橫軸及主軸連結的橡膠過軟，請換用較硬的橡膠。

**Q&A 7** **While in flybarless setup mode, unable to complete ELE/AIL endpoint and reverse settings.**  
 Disable all trims/subtrims on the transmitter.

進入Flybarless設定，無法順利完成ELE、AIL行程、ELE或AIL的REV燈號？

未取消遙控器的內外微調。

**Q&A 8** **Incorrect CCPM mixing after initial flybarless setup.**

(1) Trim/subtrims not zeroed out on transmitter.

(2) After any trim adjustments are done on transmitter, the initial flybarless setup procedure need to be performed again.

(3) Please turn off the swash ring, Linkage Compensation, Swash Mix, Mixing, Acceleration and other collective mixing functions in the transmitter.

完成Flybarless設定，但CCPM混控動作不正常？

- (1) 進入Flybarless設定時未將外微調歸零。
- (2) 遙控器變更內微調，未重新進行Flybarless設定。
- (3) 請關閉遙控器內Swash ring、Linkage Compensation、Swash Mix、Mixing、Acceleration等混控功能。

**Q&A 9** **3G flybarless system unable to power up.**  
 (1) Check proper voltage source.  
 (2) Check AIL/ELE/PIT connections between flybarless control unit and receiver.  
 (3) Check for connection between flybarless control unit and sensor.

3G Flybarless無法開機？

- (1) 檢查系統電源是否正確。
- (2) 檢查AIL、ELE及PIT的訊號線和接收器是否正確連接。
- (3) 檢查感應器與控制器訊號線是否正確連接。

**Q&A 10** **3G flybarless system powers up with LED flashing, but swashplate did not jump 3 times, pitch is locked, unable to complete the initialization process.**

(1) Possible movement during initialization process. Make sure helicopter is absolutely stationary.

(2) If STATUS LED flashes red, check the connection between flybarless controller and sensor.

3G Flybarless開機後閃燈正常，十字盤未跳動，PIT被鎖定，無法順利完成開機動作？

- (1) 開機時直昇機必須完全靜止，才可順利開機。
- (2) 檢查如果STATUS紅綠燈號一直閃爍，請檢查控制器和感應器之間是否連接良好。

**Q&A 11** **I noticed swashplate tilts slightly at extreme pitch due to servo interactions, should I make efforts to level it out?**  
 No. Level the swashplate at 0 degrees using subtrims ONLY in DIR setup mode. (please refer to page 23 step 1.3)  
 End point swashplate interactions are automatically compensated by the 3G system while in flight.

十字盤移動到最高與最低位置時會有些微傾斜，我能嘗試將它修正調整到水平嗎？

否。在DIR模式時利用內微調(Subtrims)將十字盤0度時調整至水平(參閱第23頁 步驟1.3)，實際飛行時，3G系統會自動修正十字盤的混控位差。

**Q&A 12** **I want to trim the heli differently for different flight conditions.**  
 After initial DIR setup is complete, the trim tabs on your TX can be used to trim the heli. Use your TX's flight condition functions to have multiple trim settings. Do not adjust the subtrim unless you are in the DIR setup mode!

如何針對不同飛行模式做個別的微調設定？

在DIR模式設定完成後，依個別飛行模式(一般/3D/F3C)，使用遙控器外微調調整停懸時的水平，非DIR模式下，不可調整內微調(Subtrims)。

**Q&A 13** **What adjustments can I make on the transmitter after the DIR setup has been completed?**  
 You can adjust the trim tabs, dual rates, exponential, collective pitch, and ail/elev swash AFR (for roll rate). Again do NOT adjust the subtrims unless followed by repeating of DIR setup steps.

在離開DIR模式後，有哪些調整功能是我能使用的？

一般開機模式下，你仍然可以使用以下幾個功能調整直升機：外微調(trim tabs)、舵面大小動(dual rates, exponential)、集體螺距(collective pitch)、升降/副翼混控速率(ail/elev swash AFR (for roll rate))。

**Q&A 14** **During step 5 of DIR setup mode, only aileron swash mixing was mentioned. Should I set elevator swash mixing as well?**  
 No. The 3G system automatically calculates a cyclic ring based on the aileron swash mix percentage. Setting of elevator swash mix has no affect on the 3G system. Set the cyclic pitch by the aileron swash mix & just use the same value for elevator.

在步驟五-循環螺距設定時，為何只測量副翼的角度？

3G系統在實際飛行時，會自動給定十字盤一個限圍運行，所以在測量副翼循環螺距角度後，設定相同數值的升降循環角度即可。

# ALIGN

## Specifications & Equipment/規格配備:

Length/機身長: 1328mm

Height/機身高: 408mm

Main Blade Length/主旋翼長: 690mm

Main Rotor Diameter/主旋翼直徑: 1562mm

Tail Rotor Diameter/尾旋翼直徑: 281mm

Motor Drive Gear/馬達齒輪: 12T

Main Drive Gear/主齒輪: 115T

Autorotation Tail Drive Gear/尾驅動主齒: 104T

Drive Gear Ratio/齒輪傳動比: 1:9.58:4.33

Weight(With Motor)/空機重(含馬達): 2830g

Flying Weight/全配重: Approx. 4700g

