

T-REX Nitro Pro 700

INSTRUCTION MANUAL

使用說明書

KX018001TA



Contents	
1	INTRODUCTION 前言
1~2	SAFETY NOTES 安全注意事項
3	EQUIPMENT REQUIRED FOR ASSEMBLY 自備設備
4	SAFETY CHECK BEFORE FLYING 飛行前安全檢查
5~22	ASSEMBLY SECTION 組裝說明
23	EQUIPMENT INSTALLATION 各項設備配置圖
24	SERVO AND LINKAGE ROD SETTING ILLUSTRATION 伺服器與連桿設定視圖
24	CANOPY ASSEMBLY 機頭罩安裝
25	ELECTRIC EQUIPMENT ILLUSTRATION 電子設備建議配置圖示
26	SERVO SETTING AND ADJUSTMENT 伺服器設定調整
26	ADJUSTMENTS FOR GYRO AND TAIL NEUTRAL SETTING 陀螺儀與尾翼中立點調整
27	PITCH AND THROTTLE SETTING 主旋翼螺距與油門設定
28~29	GOVERNOR INSTRUCTION MANUAL 定速器安裝使用說明
30	2 IN 1 VOLTAGE REGULATOR INSTRUCTION MANUAL 2合1降壓器安裝使用說明
31~35	FLIGHT ADJUSTMENT AND SETTING 飛行動作調整與設定
36~46	PART NAMES AND OPTIONAL PART LIST 各部零件名稱與選購備品明細



Thank you for buying ALIGN products. The **T-REX 700Nitro PRO** is the latest technology in Rotary RC models. Please read this manual carefully before assembling and flying the new **T-REX 700Nitro PRO** helicopter. We recommend that you keep this manual for future reference regarding tuning and maintenance.

承蒙閣下選用亞拓遙控世界系列產品，謹表謝意。進入遙控世界之前必須告訴您許多相關的知識與注意事項，以確保您能夠在學習的過程中較得心應手。在開始操作之前，請務必詳閱本說明書，相信一定能夠給您帶來相當大的幫助，也請您妥善保管這本說明書，以作為日後參考。

Thank you for buying ALIGN Products. The T-REX 700N Helicopter is designed as an easy to use, full featured Helicopter R/C model capable of all forms of rotary flight. Please read the manual carefully before assembling the model, and follow all precautions and recommendations located within the manual. Be sure to retain the manual for future reference, routine maintenance, and tuning. The T-REX 700N is a new product developed by ALIGN. It provides flying stability for beginners, full aerobatic capability for advanced fliers, and unsurpassed reliability for customer support.

感謝您選購亞拓產品，為了讓您容易方便的使用 T-REX 700N 直昇機、請您詳細的閱讀完這本說明書之後再進行組裝以及操作這台直昇機，同時請您妥善的保存這本說明書、作為日後進行調整以及維修的參考。T-REX 700N 是由亞拓自行研發的新產品，不論你是需求飛行穩定性的初學者或是追求性能的飛行愛好者。T-REX 700N 將是你最佳的選擇。

THE MEANING OF SYMBOLS 標誌代表涵義

 WARNING 警告	Mishandling due to failure to follow these instructions may result in damage or injury. 因為疏忽這些操作說明，而使用錯誤可能造成財產損失或嚴重傷害。
 CAUTION 注意	Mishandling due to failure to follow these instructions may result in danger. 因為疏忽這些操作說明，而使用錯誤可能造成危險。
 FORBIDDEN 禁止	Do not attempt under any circumstances. 在任何禁止的環境下，請勿嘗試操作。

IMPORTANT NOTES 重要聲明

R/C helicopters, including the T-REX 700N are not toys. R/C helicopter utilize various high-tech products and technologies to provide superior performance. Improper use of this product can result in serious injury or even death. Please read this manual carefully before using and make sure to be conscious of your own personal safety and the safety of others and your environment when operating all ALIGN products.

Manufacturer and seller assume no liability for the operation or the use of this product.

Intended for use only by adults with experience flying remote control helicopters at a legal flying field. After the sale of this product we cannot maintain any control over its operation or usage.

T-REX 700N 遙控直昇機並非玩具，它是結合了許多高科技產品所設計出來的休閒用品，所以商品的使用不當或不熟悉都可能造成嚴重傷害甚至死亡，使用之前請務必詳讀本說明書，勿輕忽並注意自身安全。注意!任何遙控直昇機的使用，製造商和經銷商是無法對使用者於零件使用的損耗異常或組裝不當所發生之意外負任何責任，本產品是提供給有操作過模型直昇機經驗的成人或有相當技術的人員在旁指導於當地合法遙控飛行場飛行，以確保安全無虞下操作使用，產品售出後本公司將不負任何操作和使用控制上的任何性能與安全責任。

We recommend that you obtain the assistance of an experienced pilot before attempting to fly our products for the first time. A local expert is the best way to properly assemble, setup, and fly your model for the first time. The Helicopter requires a certain degree of skill to operate, and is a consumer item. Any damage or dissatisfaction as a result of accidents or modifications are not covered by any warranty and cannot be returned for repair or replacement. Please contact our distributors for free technical consultation and parts at discounted rates when you experience problems during operation or maintenance.

模型商品屬於需高操作技術且為消耗性之商品，如經拆裝使用後，會造成不等情況零件損耗，任何使用情況所造成商品不良或不滿意，將無法於保固條件內更換新品或退貨，如遇有使用操作維修問題，本公司全省分公司或代理商將提供技術指導、特價零件供應服務。

2. SAFETY NOTES 安全注意事項



Fly only in safe areas, away from other people. Do not operate R/C aircraft within the vicinity of homes or crowds of people. R/C aircraft are prone to accidents, failures, and crashes due to a variety of reasons including, lack of maintenance, pilot error, and radio interference. Pilots are responsible for their actions and damage or injury occurring during the operation or as of a result of R/C aircraft models.

遙控模型飛機、直昇機屬高危險性商品，飛行時務必遠離人群，人為組裝不當或機件損壞、電子控制設備不良，以及操控上的不熟悉、都有可能導致飛行失控損傷等不可預期的意外，請飛行者務必注意飛行安全，並需了解自負疏忽所造成任何意外之責任。



LOCATE AN APPROPRIATE LOCATION 遠離障礙物及人群

R/C helicopters fly at high speed, thus posing a certain degree of potential danger. Choose an a legal flying field consisting of flat, smooth ground without obstacles. Do not fly near buildings, high voltage cables, or trees to ensure the safety of yourself, others and your model. For the first practice, please choose a legal flying field and can use a training skid to fly for reducing the damage. Do not fly your model in inclement weather, such as rain, wind, snow or darkness.

直昇機飛行時具有一定的速度，相對的也潛在著危險性，場地的選擇也相對的重要，請需遵守當地法規到合法遙控飛行場地飛行。必須注意周遭有沒有人、高樓、建築物、高壓電線、樹木等等，避免操控的不當造成自己與他人財產的損壞。初次練習時，務必選擇在空曠合法專屬飛行場地並適當搭配練習架練習飛行，這對飛行失誤所造成的損傷將會大幅的降低。請勿在下雨、打雷等惡劣天候下操作，以確保本身及機體的安全。



PREVENT MOISTURE 遠離潮濕環境

R/C models are composed of many precision electrical components. It is critical to keep the model and associated equipment away from moisture and other contaminants. The introduction or exposure to water or moisture in any form can cause the model to malfunction resulting in loss of use, or a crash. Do not operate or expose to rain or moisture.

直昇機內部也是由許多精密的電子零組件組成，所以必須絕對的防止潮濕或水氣，避免在浴室或雨天時使用，防止水氣進入機身內部而導致機件及電子零件故障而引發不可預期的意外！



PROPER OPERATION 勿不當使用本產品

Please use the replacement of parts on the manual to ensure the safety of instructors. This product is for R/C model, so do not use for other purpose.

請勿自行改造加工，任何的升級改裝或維修，請使用亞拓產品目錄中的零件，以確保結構的安全。請確認於產品限界內操作，請勿過載使用，並勿用於安全、法令外其它非法用途。



OBTAIN THE ASSISTANCE OF AN EXPERIENCED PILOT 避免獨自操控

Before turning on your model and transmitter, check to make sure no one else is operating on the same frequency. Frequency interference can cause your model, or other models to crash. The guidance provided by an experienced pilot will be invaluable for the assembly, tuning, trimming, and actual first flight. (Recommend you to practice with computer-based flight simulator.)

至飛行場飛行前，需確認是否有相同頻率的同好正進行飛行，因為開啓相同頻率的發射機將導致自己與他人立即干擾等意外危險。遙控飛機操控技巧在學習初期有著一定的難度，要盡量避免獨自操作飛行，需有經驗的人士在旁指導，才可以操控飛行。(勤練電腦模擬器及老手指導是入門必要的選擇)



SAFE OPERATION 安全操作

Operate this unit within your ability. Do not fly under tired condition and improper operation may cause in danger.

請於自己能力內及需要一定技術範圍內操作這台直昇機，過於疲勞、精神不佳或不當操作，意外發生風險將可能會提高。



ALWAYS BE AWARE OF THE ROTATING BLADES 遠離運轉中零件

During the operation of the helicopter, the main rotor and tail rotor will be spinning at a high rate of speed. The blades are capable of inflicting serious bodily injury and damage to the environment. Be conscious of your actions, and careful to keep your face, eyes, hands, and loose clothing away from the blades. Always fly the model a safe distance from yourself and others, as well as surrounding objects. Never take your eyes off the model or leave it unattended while it is turned on. Immediately turn off the model and transmitter when you have landed the model.

當直昇機主旋翼與尾旋翼運轉時，切勿觸摸並遠離任何物件，以避免造成危險及損壞。



KEEP AWAY FROM HEAT 遠離熱源

R/C models are made up various forms of plastic. Plastic is very susceptible to damage or deformation due to extreme heat and cold climate. Make sure not to store the model near any source of heat such as an oven, or heater. It is best to store the model indoors, in a climate-controlled, room temperature environment.



遙控飛機多半是以 PA 纖維或聚乙烯、電子商品為主要材質，因此要盡量遠離熱源、日曬，以避免因高溫而變形甚至熔毀損壞的可能。



RADIO TRANSMITTER AND ELECTRONIC EQUIPMENT REQUIRED FOR ASSEMBLY 自備遙控及電子設備

 Transmitter (7-channel or more, helicopter system) 發射機(七動以上直昇機模式遙控器)	 Receiver(7-channel or more) 接收機(七動以上)	 Standard Servo x 4pcs 標準伺服器 x 4
 Head Lock Gyro x 1 pc 鎖定式陀螺儀 x 1	 Specialized Servo x 1 pc 尾舵控制專用伺服器 x 1	 Dial Pitch Gauge x 1pc 旋轉式螺距規 x 1
 Engine Starter/Starter Shaft x 1pc 啟動器/啟動棒 x 1	 11.1~14.8V Li-Po 2500mAh Starter Battery x 1pc 11.1-14.8V Li-Po 2500mAh 啟動電池 x 1	 Fuel Pump x 1 pc 加油器 x 1
 Engine Fuel x 1 pc 引擎燃油 x 1	 2 In 1 Voltage Regulator Combo 二合一降壓器 Combo	 91 Engine x 1 pc 91引擎 x 1
 690~710 Blade x 1set 690-710主旋翼 x 1組	 90 Muffler x 1 pc 90高效加速管 x 1	

ADDITIONAL TOOLS REQUIRED FOR ASSEMBLY 自備工具

 Scissors 剪刀	 Cutter Knife 刀子	 Diagonal Cutting Pliers 斜口鉗	 Needle Nose Pliers 尖嘴鉗
 Oil 潤滑油	 CA 瞬間膠	 Hexagon Screw Driver 六角螺絲起子 3mm/2.5mm/2mm/1.5mm	 Philips Screw Driver 十字螺絲起子 φ 3.0/φ 1.8mm

CAREFULLY INSPECT BEFORE REAL FLIGHT 實機飛行前請嚴格執行飛行前檢查義務

- ☆ **Before flying, please check to make sure no one else is operating on the same frequency for the safety.**
 - ☆ **Before flight, please check if the batteries of transmitter and receiver are enough for the flight.**
 - ☆ **Before turn on the transmitter, please check if the throttle stick is in the lowest position. IDLE switch is OFF.**
 - ☆ **When turn off the unit, please follow the power on/off procedure. Power ON- Please turn on the transmitter first, and then turn on receiver. Power OFF- Please turn off the receiver first and then turn off the transmitter. Improper procedure may cause out of control, so please to have this correct habit.**
 - ☆ **Before operation, check every movement is smooth and directions are correct. Carefully inspect servos for interference and broken gear.**
 - ☆ **Check for missing or loose screws and nuts. See if there is any cracked and incomplete assembly of parts. Carefully check main rotor blades and rotor holders. Broken and premature failures of parts possibly cause resulting in a dangerous situation.**
 - ☆ **Check all ball links to avoid excess play and replace as needed. Failure to do so will result in poor flight stability.**
 - ☆ **Check the battery and power plug are fastened. Vibration and violent flight may cause the plug loose and result out of control.**
- ★ 每次飛行前應先確認所使用的頻率是否會干擾他人，以確保你自身與他人的安全。
- ★ 每次飛行前確定您發射機與接收機電池的電量是在足夠飛行的狀態。
- ★ 開機前確認油門搖桿是否位於最低點，熄火降落開關，定速開關(IDLE)是否於關閉位置。
- ★ 關機時必須遵守電源開關機的程序，開機時應先開啓發射機後，再開啓接收機電源；關機時應先關閉接收機後，再關閉發射機電源。不正確的開關程序可能會造失控的現象，影響自身與他人的安全，請養成正確的習慣。
- ★ 開機請先確定直昇機的各個動作是否順暢，及方向是否正確，並檢查伺服器的動作是否有干涉或崩齒的情形，使用故障的伺服器將導致不可預期的危險。
- ★ 飛行前確認沒有缺少或鬆脫的螺絲與螺帽，確認沒有組裝不完整或損毀的零件，仔細檢查主旋翼是否有損壞，特別是接近主旋翼夾座的部位。損壞或組裝不完整的零件不僅影響飛行，更會造成不可預期的危險。注意：對損耗、有裂痕零件更新及定期保養檢查的重要性。
- ★ 檢查所有的連桿頭是否有鬆脫的情形，過鬆的連桿頭應先更新，否則將造成直昇機無法操控的危險。
- ★ 確認電池及電源接頭是否固定牢靠，飛行中的震動或激烈的飛行，可能造成電源接頭鬆脫而造成失控的危險。

Standard Equipment 標準配備

 700NC	 700NB	 700NB1	 700NB2	 700NB3	 700NB4	 700NB5
 700NH	 700NG	 700NT1	 700NT2	 700NT3	 700NZ	 RCE-G600 Governor RCE-G600定速器

When you see the marks as below, please use glue or grease to ensure flying safety.

標有下符號之組裝步驟，請配合上膠或上油，以確保使用之可靠度。



- CA: Apply CA Glue to fix.**
- R48: Apply Anaerobics Retainer to fix.**
- T43: Apply Thread Lock to fix.**
- OIL: Add Grease.**
- CA: 使用瞬間膠固定
- R48: 使用金屬管狀固定缺氧膠固定
- T43: 使用螺絲膠
- OIL: 添加潤滑油

When assembling ball links, make sure the "A" character faces outside.

各項塑膠製連桿頭扣接時，A字請朝外。



Grease
潤滑油



R48
綠色



T43
藍色



Self-furnished
瞬間膠(自備)

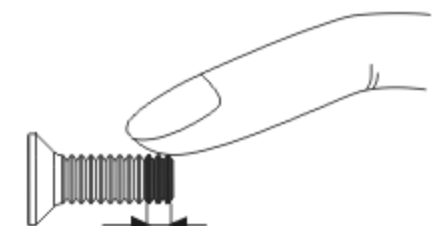

T43 Glue width: approx. 1mm
T43上膠寬度約1mm

R48 metal tubular adhesive (eg. Bearings). T43 thread lock, apply a small amount on screws or metal parts and wipe surplus off.

When disassembling, recommend to heat the metal joint about 15 Seconds.(NOTE: Keep plastic parts away from heat.)

R48 為強力金屬管狀(如軸承)接著劑，T43為螺絲膠，膠合螺絲或金屬內外徑請務必少量使用，必要時請用手去除多餘膠量，欲拆卸時可於金屬接合部位熱烤約15秒。(注意！塑膠件避免接近熱源)

700NH1A

Apply a little amount of T43 thread lock when fixing a metal part.
螺絲鎖附於金屬件請使用適量T43(螺絲膠)

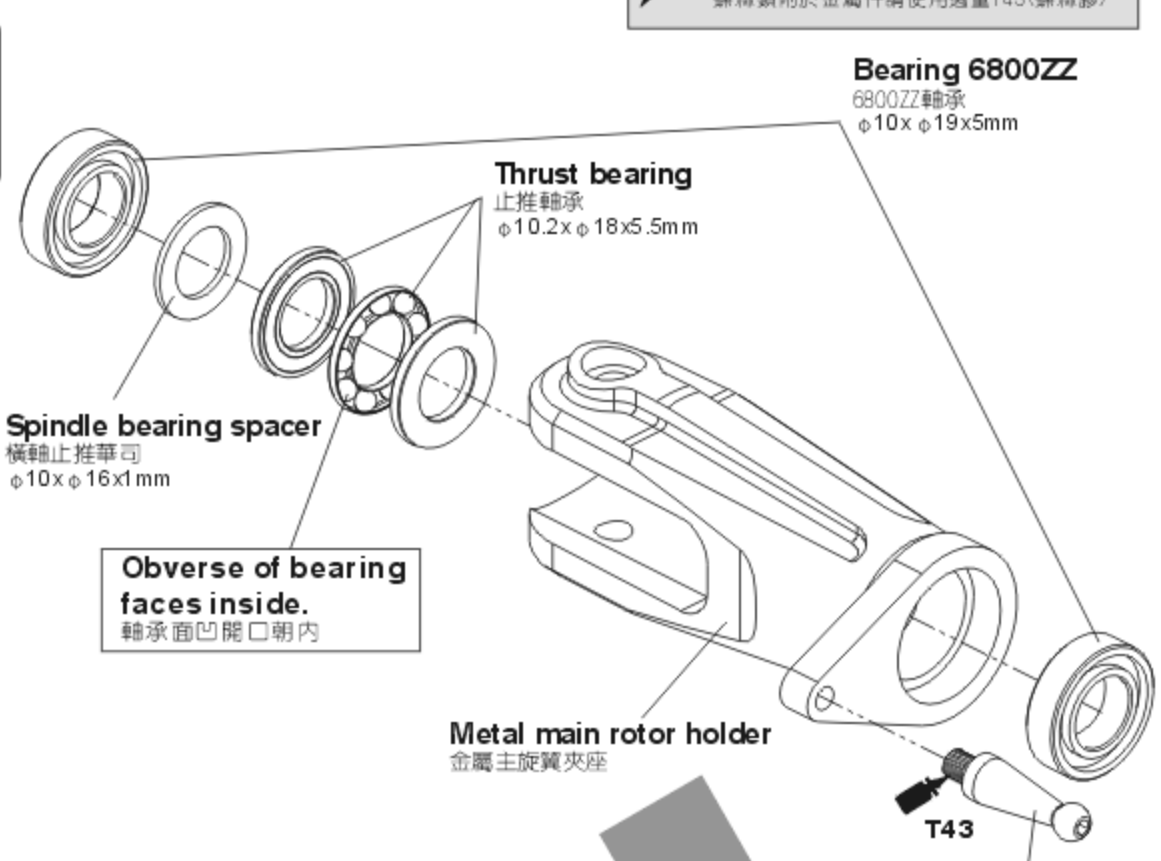
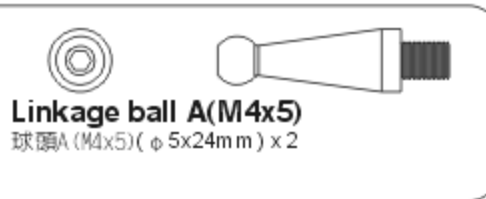
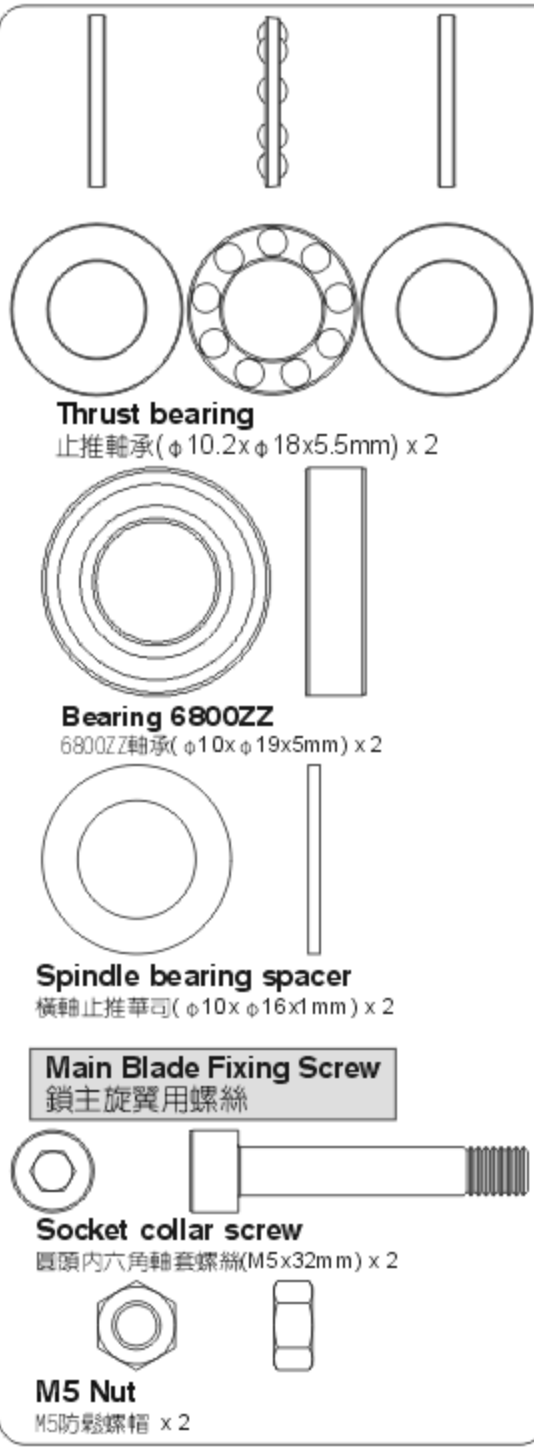

CAUTION 注意

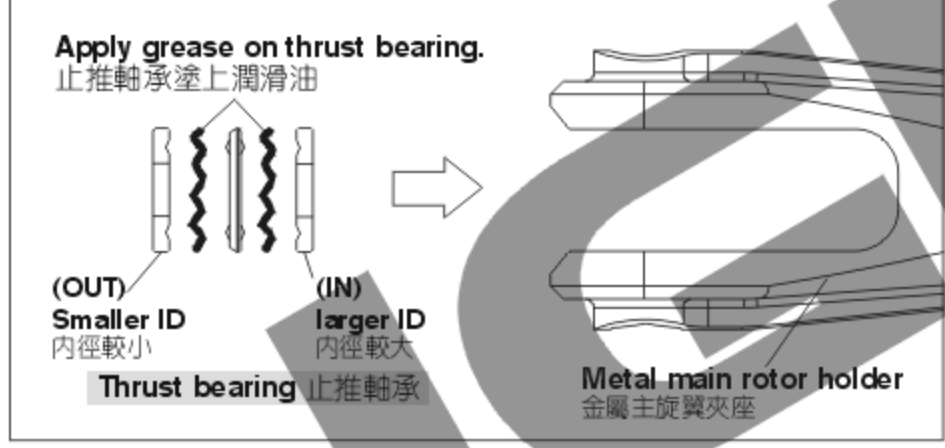

CAUTION 注意

Already assembled by Factory.
Before flying, please check if the screws are fixed with glue.
原裝組裝完成品，每一次飛行前請先確認螺絲是否已上膠不會鬆動。

700NH1A

Apply a little amount of T43 thread lock when fixing a metal part.
螺絲鎖附於金屬件請使用適量T43(螺絲膠)

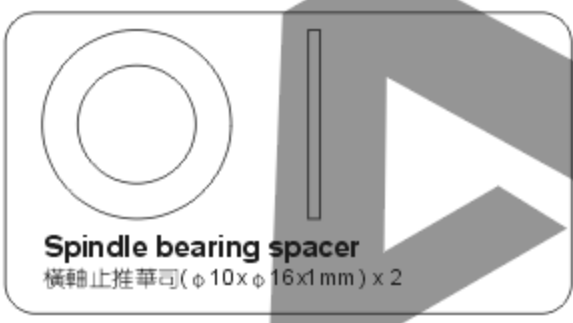

700NH2

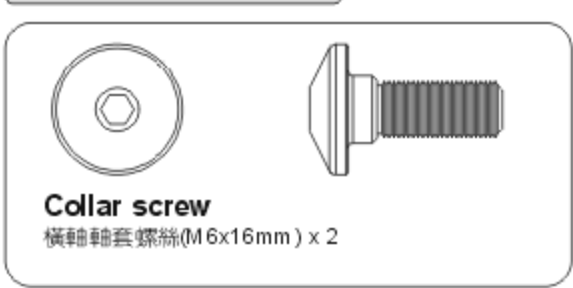

700NH2A

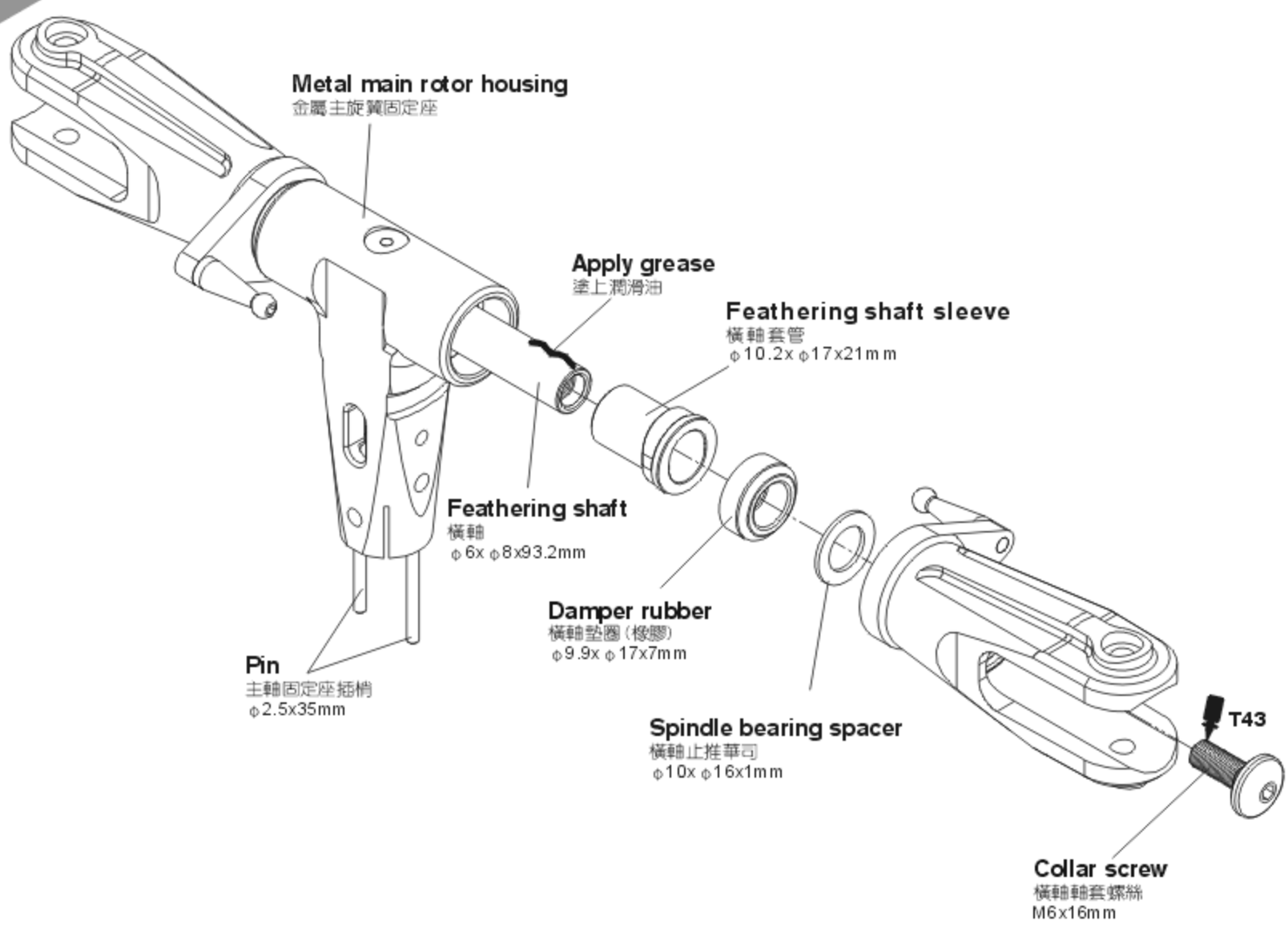
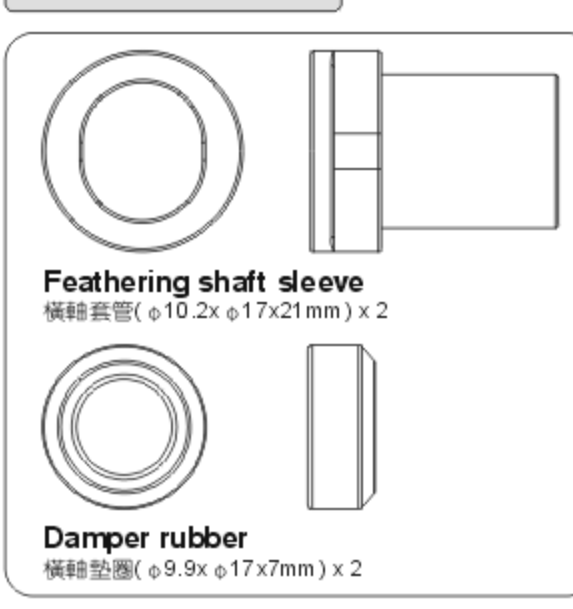

700NH2



Bearing MR104ZZ
MR104ZZ軸承(φ4xφ10x4mm) x 2



Bearing 683ZZ
683ZZ軸承(φ3xφ7x3mm) x 4



Bearing MF105ZZ
MF105ZZ軸承(φ5xφ11.2xφ10x4mm) x 2



Collar
擺臂軸承襯套(φ3xφ4.8x1.5mm) x 2



Linkage ball C(M3x3.5)
球頭C(M3x3.5)(φ5x8.5mm) x 4



Socket button head screw
半圓頭內六角螺絲(M3x12mm) x 2



M4 collar screw
M4雙層軸套螺絲(M4x10mm) x 2



Washer
華司(φ3xφ4.8x0.3mm) x 4

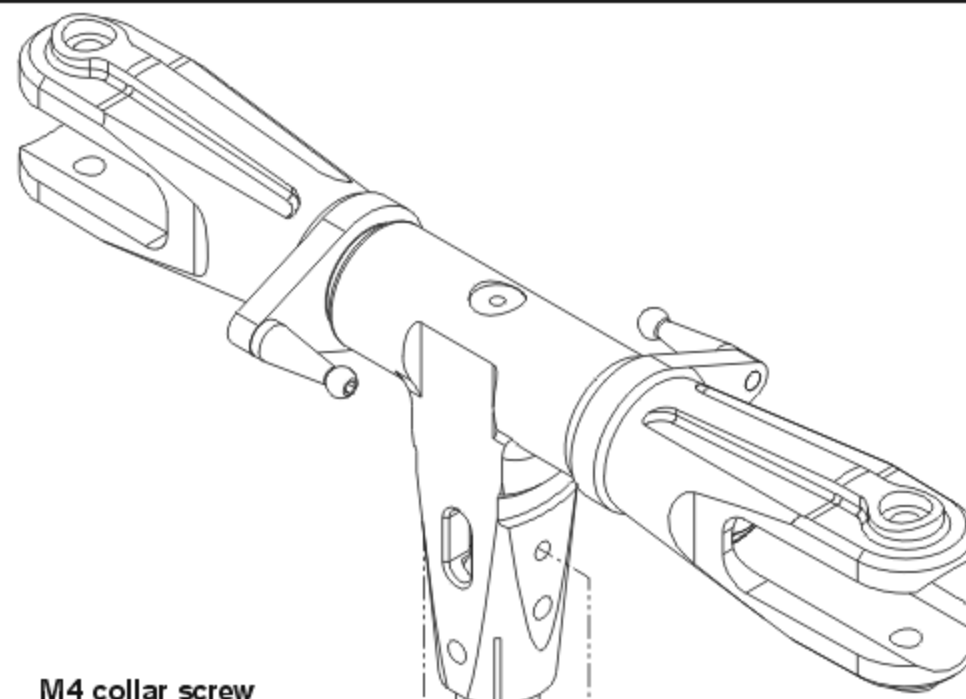

M4 collar screw
M4雙層軸套螺絲
M4x10mm

Metal flybar seesaw holder
金屬平衡桿固定座

Collar
擺臂軸承襯套
φ3xφ4.8x1.5mm

Bearing 683ZZ
683ZZ軸承
φ3xφ7x3mm

Washer
華司
φ3xφ4.8x0.3mm

Socket button head screw
半圓頭內六角螺絲
M3x12mm

Bearing MR104ZZ
MR104ZZ軸承
φ4xφ10x4mm

Bearing MF105ZZ
MF105ZZ軸承
φ5xφ11.2xφ10x4mm

Washer
華司
φ3xφ4.8x0.3mm

Linkage ball C(M3x3.5)
球頭C(M3x3.5)
φ5x8.5mm

Metal SF Mixing arm
金屬SF控制搖臂

700NH3



Socket screw
圓頭內六角螺絲(M3x6mm) x 4



M4 Set screw
M4止洩螺絲(M4x4mm) x 2



Linkage rod(B)
連桿(B) φ1.96x22mm x 2



Ball link
連桿頭 x 4

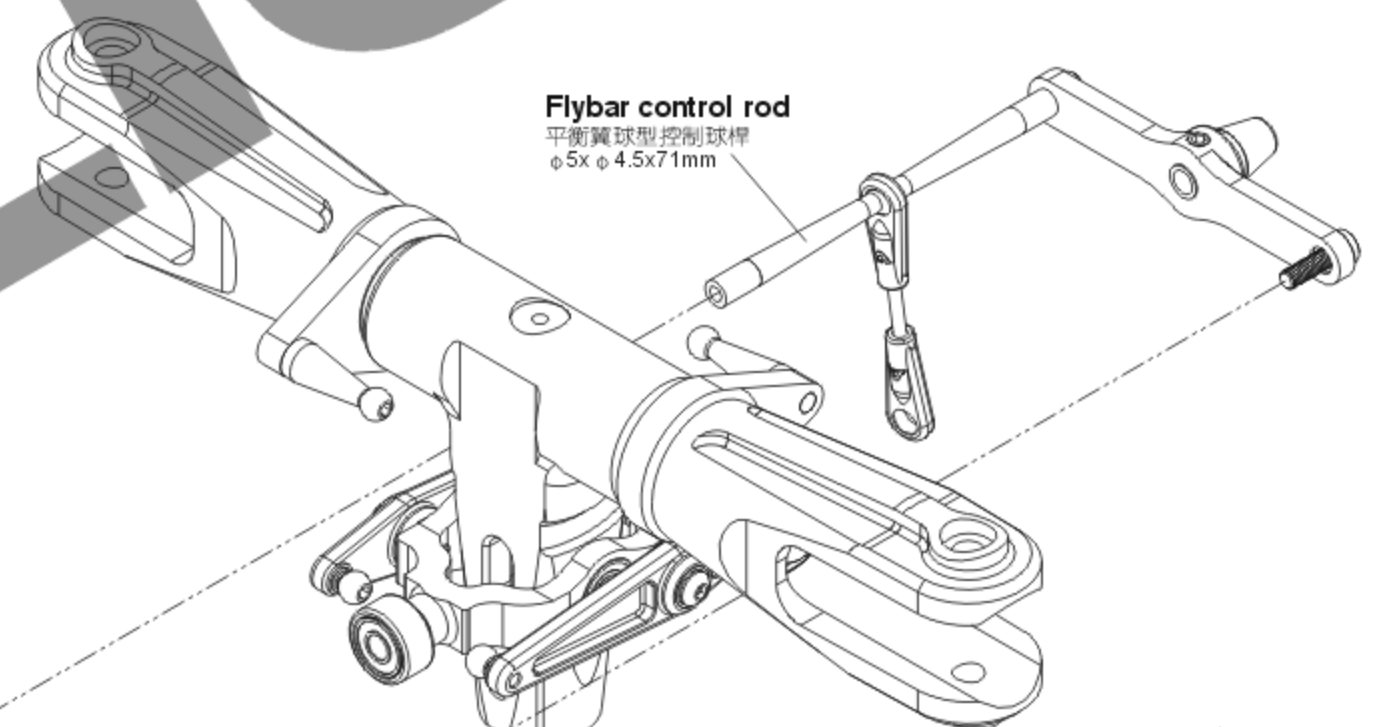

Flybar control rod
平衡翼球型控制球桿
φ5xφ4.5x71mm

Flybar rod
平衡桿
φ4x570mm

700NT3B

M4 Set screw
M4止洩螺絲
M4x4mm

Metal flybar control arm
金屬平衡翼控制臂

Socket screw
圓頭內六角螺絲
M3x6mm

Assemble linkage rod (B) before assembling flybar control set.
組裝平衡翼控制組先將連桿裝入。

Linkage rod(B)
Approx 45mm x 2
連桿(B)約45mm x 2

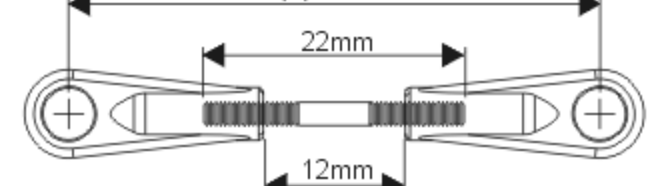

700NH4

Apply a little amount of T43 thread lock when fixing a metal part.
螺絲鎖附於金屬件請使用適量T43(螺絲膠)



Bearing 683ZZ

683ZZ軸承(φ3xφ7x3mm) x 4



Bearing FMR52ZZ

FMR52ZZ軸承(φ2xφ5x2.3mm) x 4



Socket screw

圓頭內六角螺絲(M2x5mm) x 4



Socket button head screw

半圓頭內六角螺絲(M3x12mm) x 2



Washer

華司(φ3xφ4.8x0.3mm) x 4



Collar

擺臂軸承襯套(φ3xφ4.8x1.5mm) x 2

Socket screw
圓頭內六角螺絲
M4x8mm

Socket collar screw
圓頭內六角軸套螺絲
M4x24mm

Socket screw
圓頭內六角螺絲
M4x8mm

M4 Nut
M4防鬆螺帽
M4

Main shaft
主軸
φ8xφ12x212.5mm

700NH4A



Linkage ball B(M3x4)

球頭B(M3x4)(φ5x12mm) x 2



Socket screw

圓頭內六角螺絲(M4x8mm) x 2

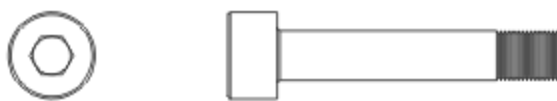

Socket collar screw

圓頭內六角軸套螺絲(M4x24mm) x 1



M4 Nut

M4防鬆螺帽 x 1

700NH5A



Linkage ball B(M3x4)

球頭B(M3x4)(φ5x12mm) x 7

Bearing FMR52ZZ
FMR52ZZ軸承
φ2xφ5x2.3mm

Socket screw
圓頭內六角螺絲
M2x5mm

Washer
華司
φ3xφ4.8x0.3mm

Metal washout base
金屬向位器

Collar
擺臂軸承襯套
φ3xφ4.8x1.5mm

Linkage ball B(M3x4)
球頭B(M3x4)
φ5x12mm

Radius arm
Radius連桿

T43

Washer
華司
φ3xφ4.8x0.3mm

Bearing 683ZZ
683ZZ軸承
φ3xφ7x3mm

Metal washout control arm
金屬穩定控制搖臂

Socket button head screw
半圓頭內六角螺絲
M3x12mm

Linkage ball B(M3x4)
球頭B(M3x4)
φ5x12mm

700NH5



CAUTION
注意

Already assembled by Factory.
Before flying, please check if
the screws are fixed with glue.
原裝相裝完成品，每一次飛行前請
先確認螺絲是否已上膠不會鬆動。

700NZ2

Linkage rod(A)
連桿(A) $\phi 1.96 \times 14 \text{mm} \times 2$

Linkage rod(C)
連桿(C) $\phi 1.96 \times 56 \text{mm} \times 2$

700NZ2A

Ball link
連桿頭 $\times 8$

700NH2A

Socket screw
圓頭內六角螺絲(M3x10mm) $\times 1$

700NH3

M3 Set screw
M3止洩螺絲(M3x6mm) $\times 2$

Apply a little amount of T43 thread lock when fixing a metal part.
螺絲鎖附於金屬件請使用適量T43(螺絲膠)

Socket screw
圓頭內六角螺絲
M3x10mm

Head stopper
旋翼頭制動器

Linkage rod(A)
Approx. 33mm $\times 2$
連桿(A)約33mm $\times 2$

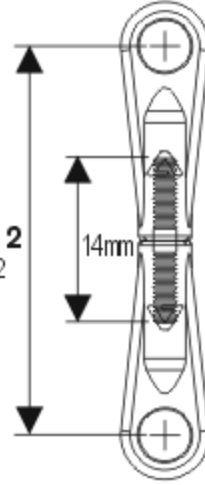

M3 Set screw
M3止洩螺絲
M3x6mm

Flybar paddle
平衡翼

Linkage rod(C)
Approx. 75.5mm $\times 2$
連桿(C)約75.5mm $\times 2$

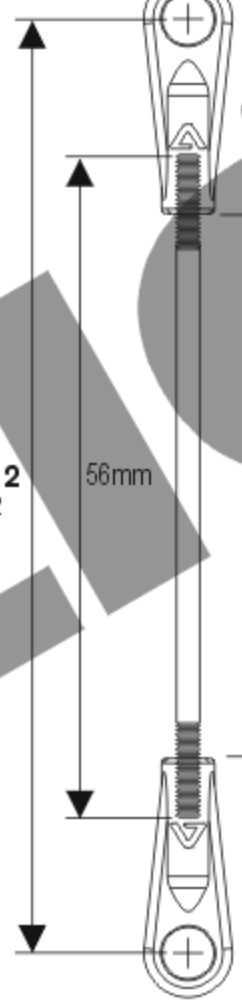

Linkage rod(B)
Approx. 43mm $\times 2$
連桿(B)約43mm $\times 2$

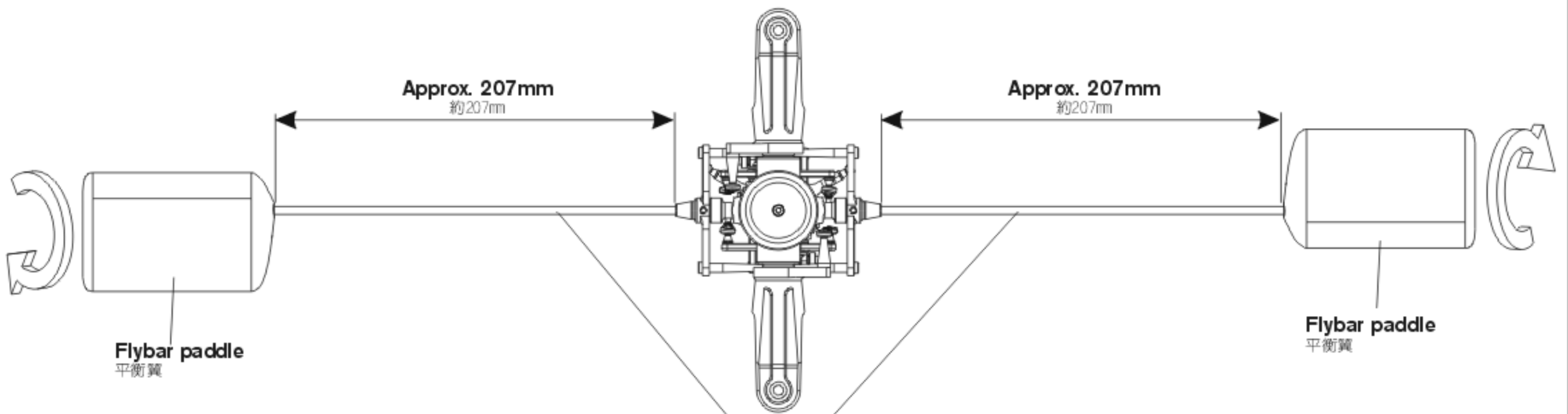
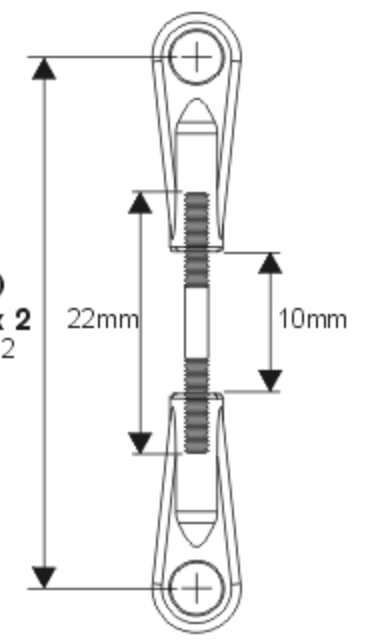

Make sure both sides are equal in length.
請保持平衡桿兩邊長度相等。

700NB3

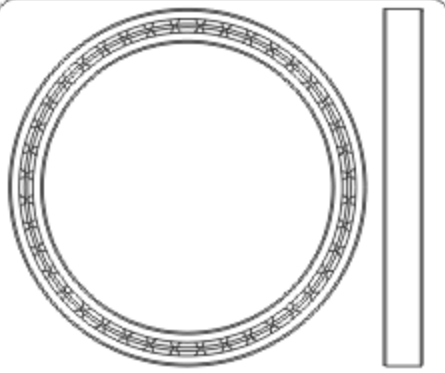

Bearing 6702ZZ
6702ZZ軸承(φ15xφ21x4mm) x 2

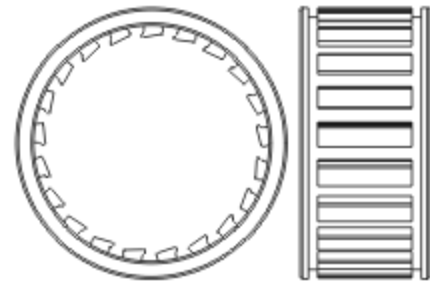

One-way bearing
單向軸承(φ15xφ23x11mm) x 1



Socket screw
圓頭內六角螺絲(M2.5x8mm) x 6



Socket button head screw
半圓頭內六角螺絲(M3x6mm) x 6

Socket button head screw
半圓頭內六角螺絲
M3x6mm

One-way bearing shaft
單向軸承套
φ12xφ15x41.5mm

One-way bearing cover
單向軸承上蓋
φ21xφ15.8x26mm

Bearing 6702ZZ
6702ZZ軸承
φ15xφ21x4mm

One-way bearing mount
單向軸承下座
φ21xφ6.5x33.1mm

One-way bearing collar
單向軸承外環
φ6xφ23x11.6mm

Main drive gear
主齒盤
164T

Apply grease
塗上潤滑油

Autorotation tail drive gear
尾驅動齒
150T

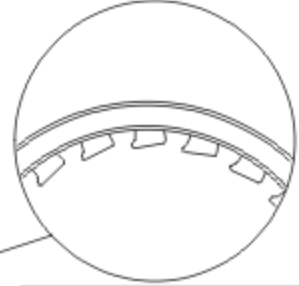

Please note the direction of bearing.
請注意軸承方向

Socket screw
圓頭內六角螺絲
M2.5x8mm

Before tightening the screw, please rotate the bearing and check the concentricity of the bearing. Then apply some glue evenly on the screw and tighten it firmly, to avoid the bearing stuck or heavy load at one side and cause slip.

上緊螺絲前請試轉動確認軸承同心度良好後，才能將螺絲平均上膠鎖緊，以避免造成卡死或單向重負載可能產生的打滑。

CAUTION
注意

Already assembled by Factory. Before flying, please check if the screws are fixed with glue.
原裝組裝完成品，每一次飛行前請先確認螺絲是否已上膠不會鬆動。

700NB4A



M4 Set screw
M4止洩螺絲(M4x4mm) x 2

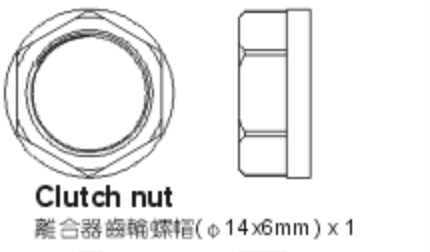

Clutch nut
離合器齒輪螺帽(φ14x6mm) x 1



Bearing 695ZZ
695ZZ軸承(φ5xφ13x4mm) x 2

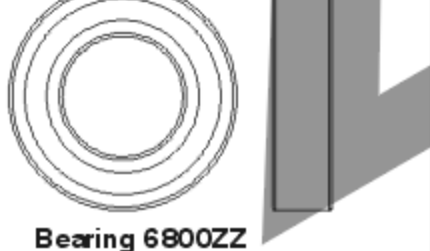

Bearing 6800ZZ
6800ZZ軸承(φ10xφ19x5mm) x 2

Socket screw
圓頭內六角螺絲
M3x8mm

Hex mounting bolt
六角機身鉚柱
φ2.5x60.5mm

M3 Nut
M3防鬆螺帽

Bearing 695ZZ
695ZZ軸承
φ5xφ13x4mm

M4 Set screw
M4止洩螺絲
M4x4mm

Starter coupling
六角啓動頭
φ8xφ10x18mm

M4 Set screw
M4止洩螺絲
M4x4mm

Clutch nut
離合器齒輪螺帽
φ14x6mm

Bearing 6800ZZ
6800ZZ軸承
φ10xφ19x5mm

Socket screw
圓頭內六角螺絲
M3x8mm

M3 Nut
M3防鬆螺帽

Clutch gear
離合器齒輪
φ7xφ15.4x40.9mm

Clutch bearing block
離合器軸承座

Option equipment: Magnet (Governor sensor)
另購：定速感應磁鐵

700NB4B



Socket screw
圓頭內六角螺絲(M3x8mm) x 2



M3 Nut
M3防鬆螺帽 x 2

Clutch bell
離合器齒
φ51xφ56x20.5mm

R48

Bearing 695ZZ
695ZZ軸承
φ5xφ13x4mm

Clutch liner
離合器來令片
1x9x158mm

Already assembled by factory, please note to check again.
已組裝完成，請務必自行再確認。

Clutch/Start shaft
啓動軸
φ5xφ12x82mm

700NB1A



Socket button head collar screw
半圓頭內六角軸套螺絲(M3x8mm) x 2



Socket button head screw
半圓頭內六角螺絲(M3x12mm) x 1



Socket screw
圓頭內六角螺絲(M3x8mm) x 2



Linkage ball C(M3x3.5)
球頭C(M3x3.5)(φ5x8.5mm) x 2



M3 Specialty washer
M3特殊華司(φ3xφ8x2mm) x 2



Washer
華司(φ3xφ4.8x0.3mm) x 2

700NB5A



Socket button head self tapping screw
半圓頭內六角自攻螺絲(T2.6x6mm) x 3



Socket screw
圓頭內六角螺絲(M3x12mm) x 1



Washer
華司(φ3xφ8x1mm) x 1

700NB1



Socket screw
圓頭內六角螺絲(M3x14mm) x 1

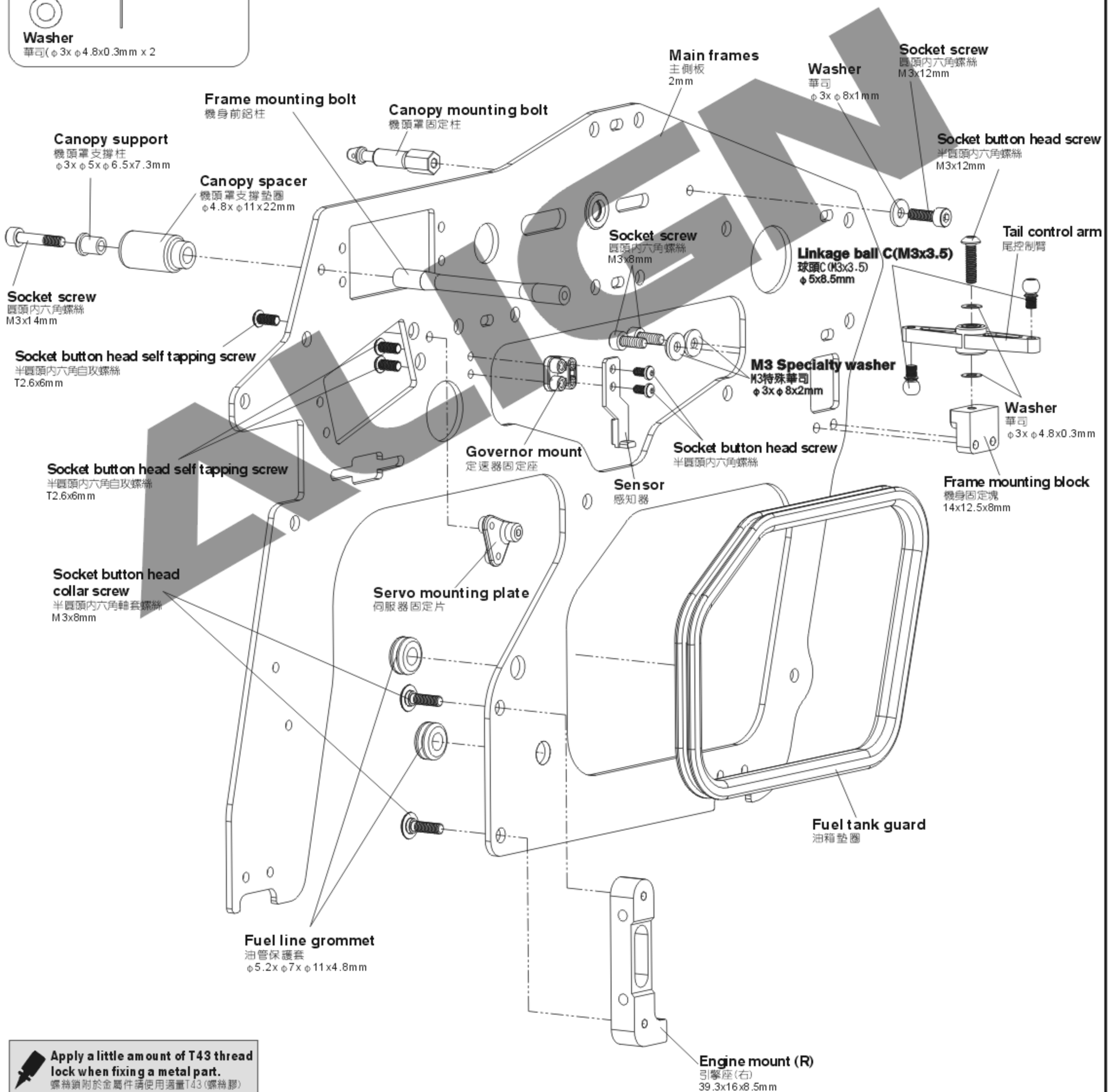

Apply a little amount of T43 thread lock when fixing a metal part.
螺絲鎖附於金屬件請使用適量T43(螺絲膠)

700NB1



Socket screw
圓頭內六角螺絲(M3x14mm) x 1



Socket button head collar screw
半圓頭內六角軸套螺絲(M3x8mm) x 8

700NB1A



Socket button head collar screw
半圓頭內六角軸套螺絲(M3x8mm) x 12

700NB5A

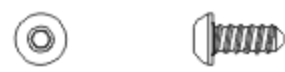

Socket button head self tapping screw
半圓頭內六角自攻螺絲(T2.6x6mm) x 1



Socket screw
圓頭內六角螺絲(M3x12mm) x 1



M3 Set screw
M3止洩螺絲(M3x15mm) x 2



Socket button head collar screw
半圓頭內六角軸套螺絲(M3x8mm) x 6



Washer
華司(φ3xφ8x1mm) x 1

700NB4B



Socket button head collar screw
半圓頭內六角軸套螺絲(M3x8mm) x 4

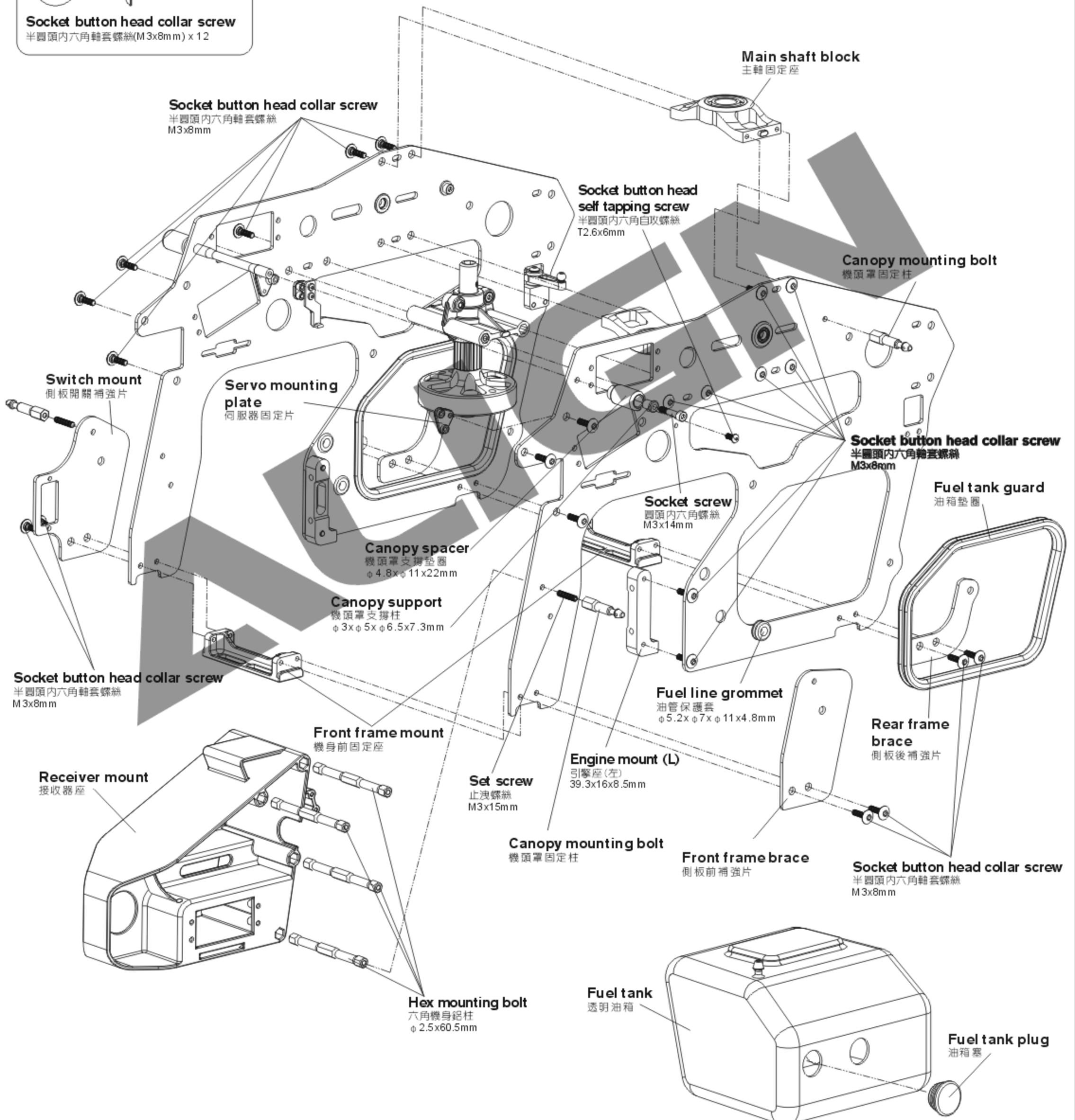

700NB4A



Socket screw

圓頭內六角螺絲(M3x12mm) x 2



Socket head spring screw

圓頭內六角彈簧螺絲(M4x8mm) x 2



Socket button head screw

半圓頭內六角螺絲(M4x5mm) x 4

700NB4B



Socket button head collar screw

半圓頭內六角軸套螺絲(M3x8mm) x 4

Socket button head collar screw
半圓頭內六角軸套螺絲
M3x8mm

700NB1A



Socket screw

圓頭內六角螺絲(M4x16mm) x 4



M4 Washer

M4華司(φ4xφ10x1mm) x 4

M4 Washer

M4華司
φ4xφ10x1mm

Socket screw

圓頭內六角螺絲
M4x16mm

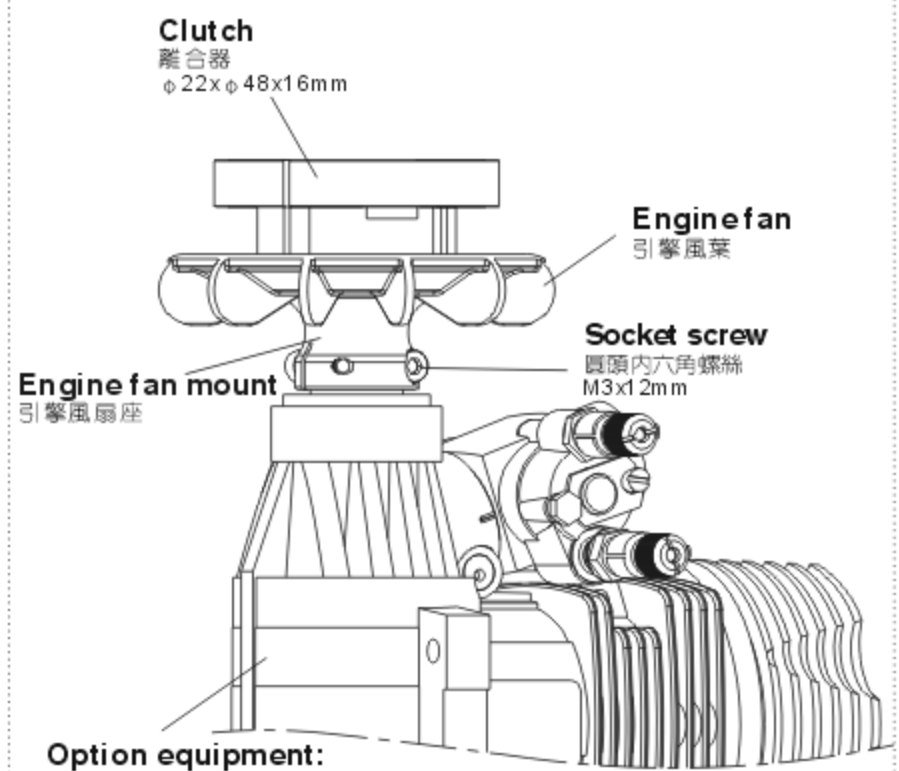
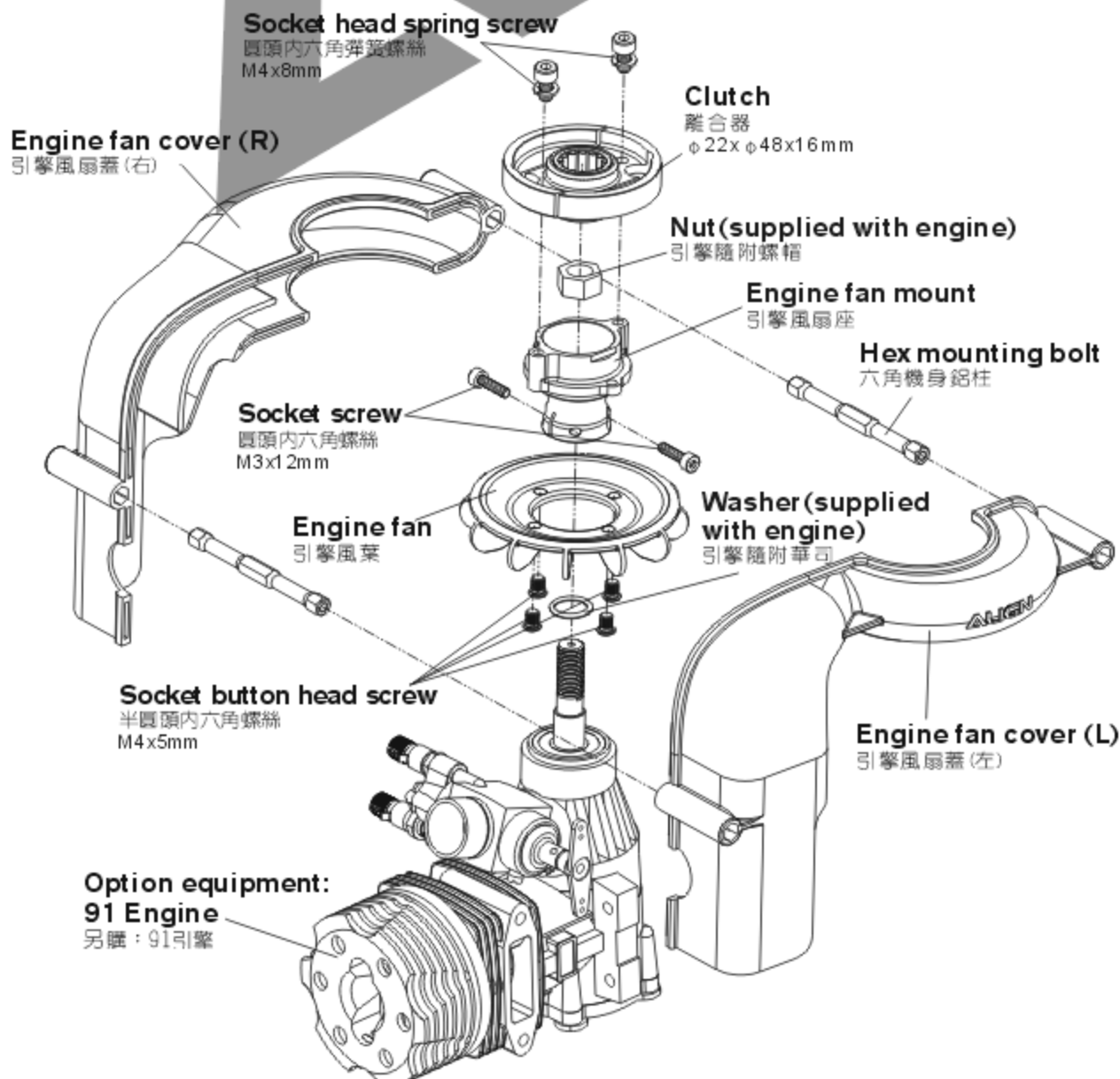

Option equipment:
91 Engine
另購: 91引擎

After install the engine into the model, please loosen the fixing screw and adjust the carburetor and the engine are at an angle of 90°(Vertical).

引擎裝入機體後請鬆開固定螺絲將化油器調成與引擎垂直。

Apply a little amount of T43 thread lock when fixing a metal part.
螺絲鎖附於金屬件請使用適量T43(螺絲膠)

Main frame assembly point:

First do not fully tighten the screws of main frames and put two bearings through the main shaft to check if the movements are smooth. The bottom bracket must be firmly touched the level table top (glass surface); please keep the smooth movements on main shaft and level bottom bracket, then slowly tighten the screws. This assembly can help for the power and flight performance.

機身側板組立重點：
側板螺絲先不完全鎖緊，放入主軸貫穿二顆軸承確認上下移動必需滑順，主體底板必須與水平桌面（玻璃平面）踏實緊貼；請保持主軸滑順與底板平行桌面後慢慢鎖緊螺絲。正確側板的組裝對動力與飛行性能有顯著幫助。

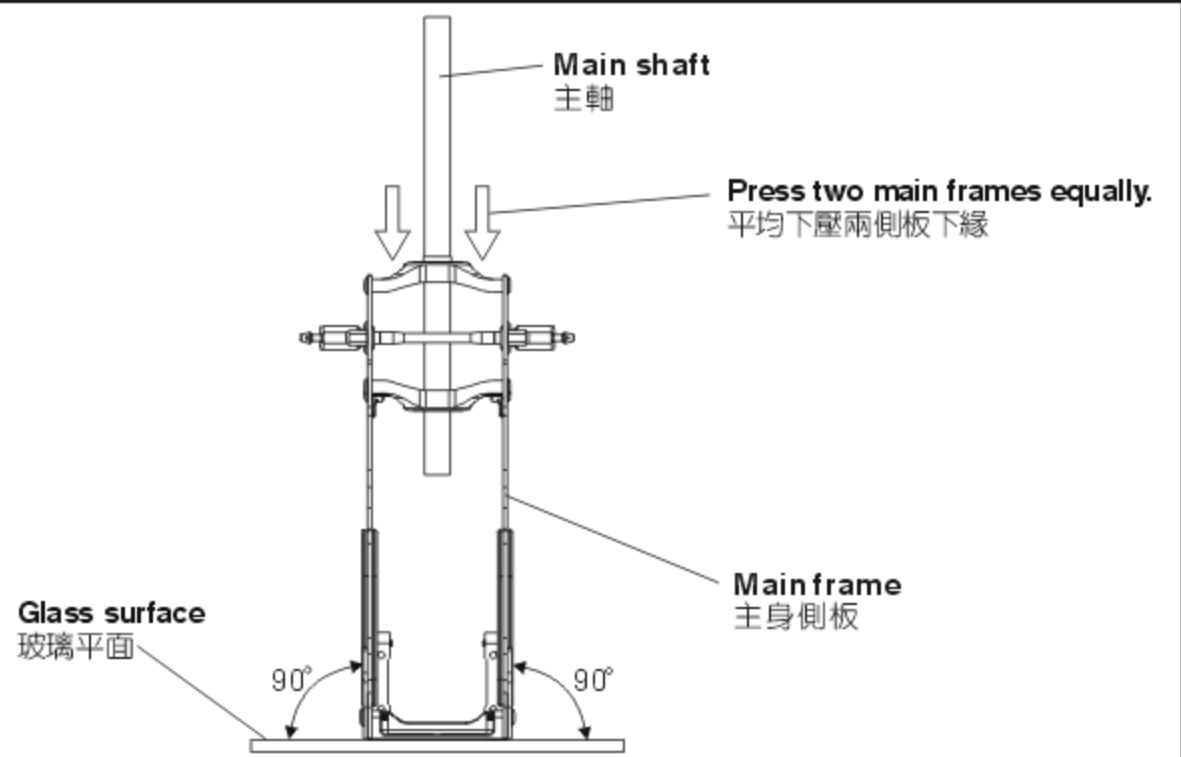

700NB1A



700NG1

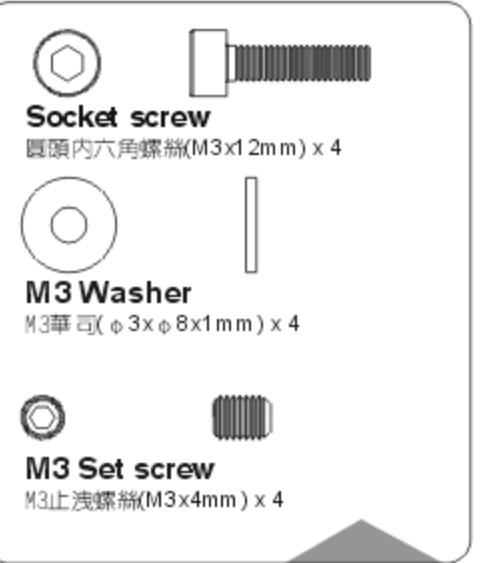

Apply a little amount of T43 thread lock when fixing a metal part.
螺絲鎖附於金屬件請使用適量T43(螺絲膠)

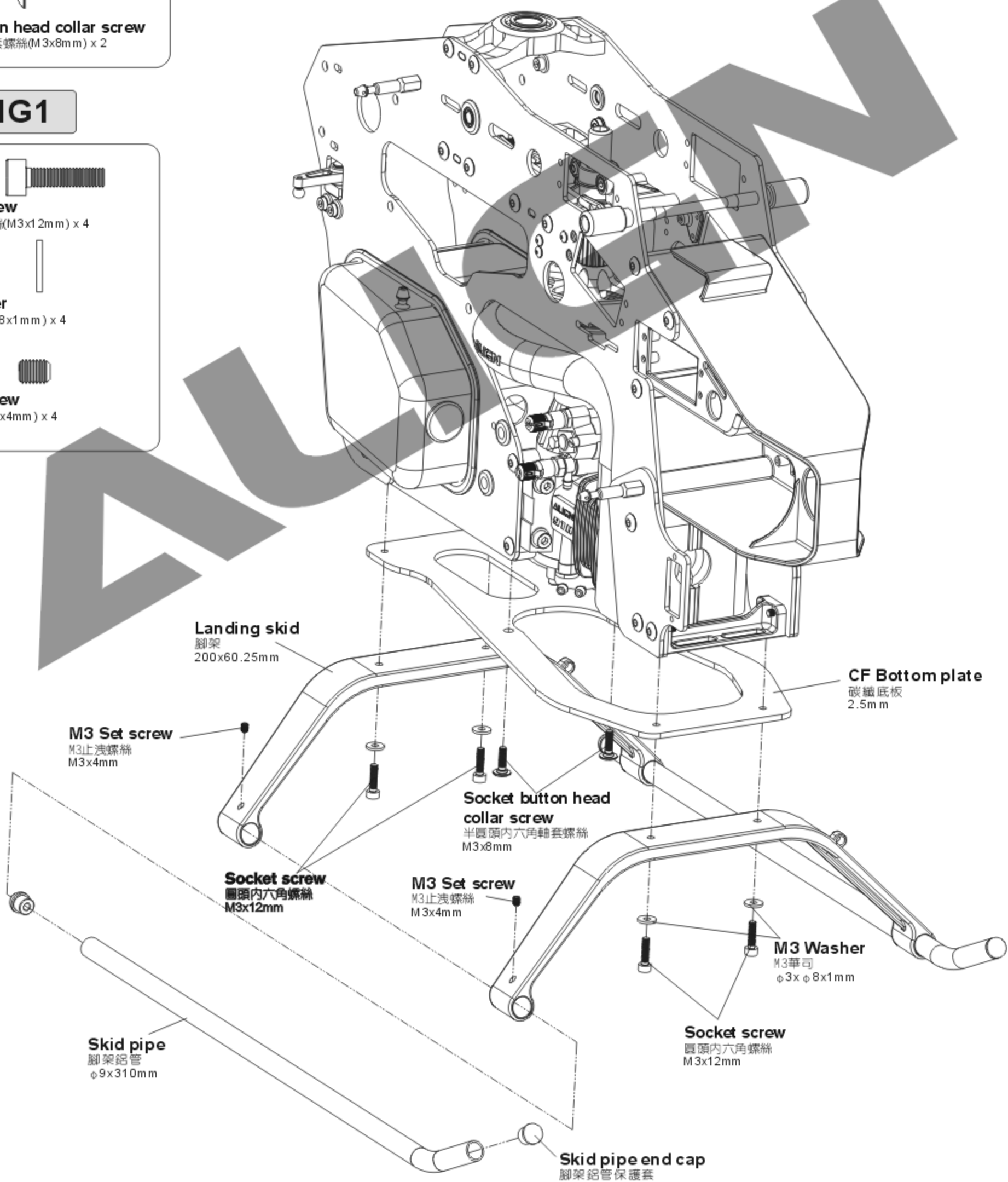

700NZ4

700NB5A

700NT3BA

- Linkage ball C(M2x5)**
球頭C(M2x5)(φ5x10mm) x 5
- Socket button head self tapping screw**
半圓頭內六角自攻螺絲(T2.6x14mm) x 12
- M2 Nut**
M2螺帽 x 5

- Socket button head self tapping screw**
半圓頭內六角自攻螺絲(T2.6x14mm) x 4

- Ball link**
連桿頭 x 2

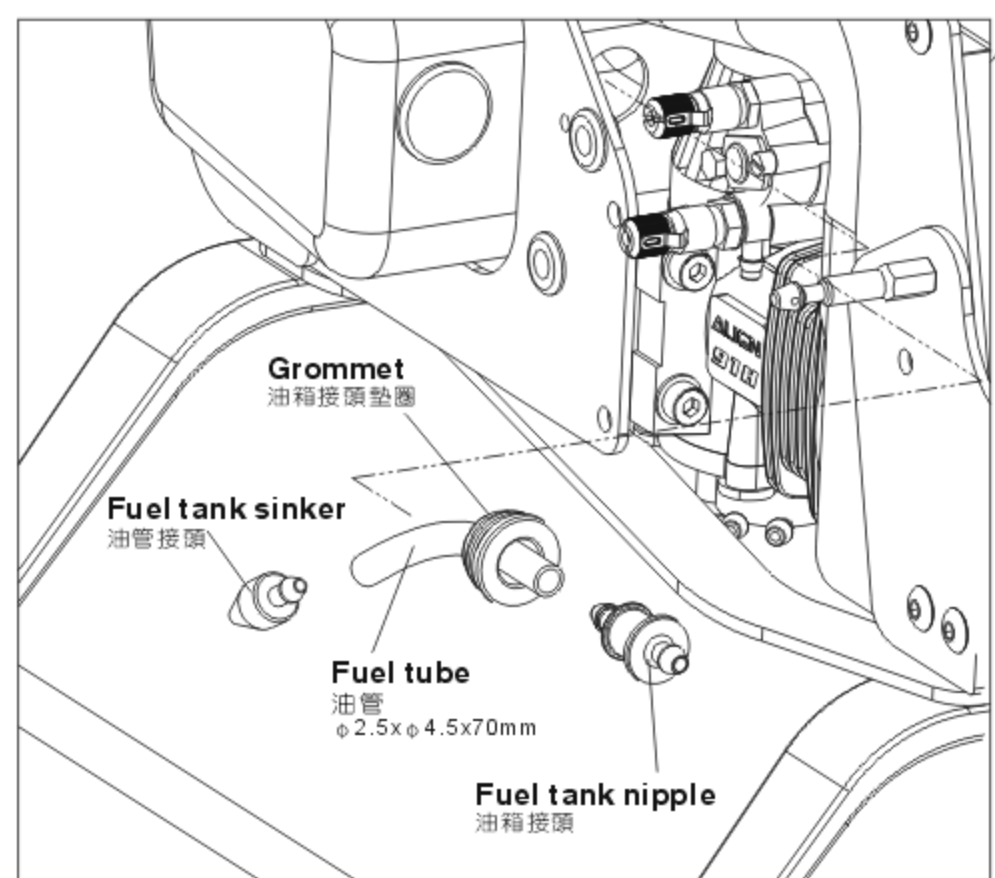
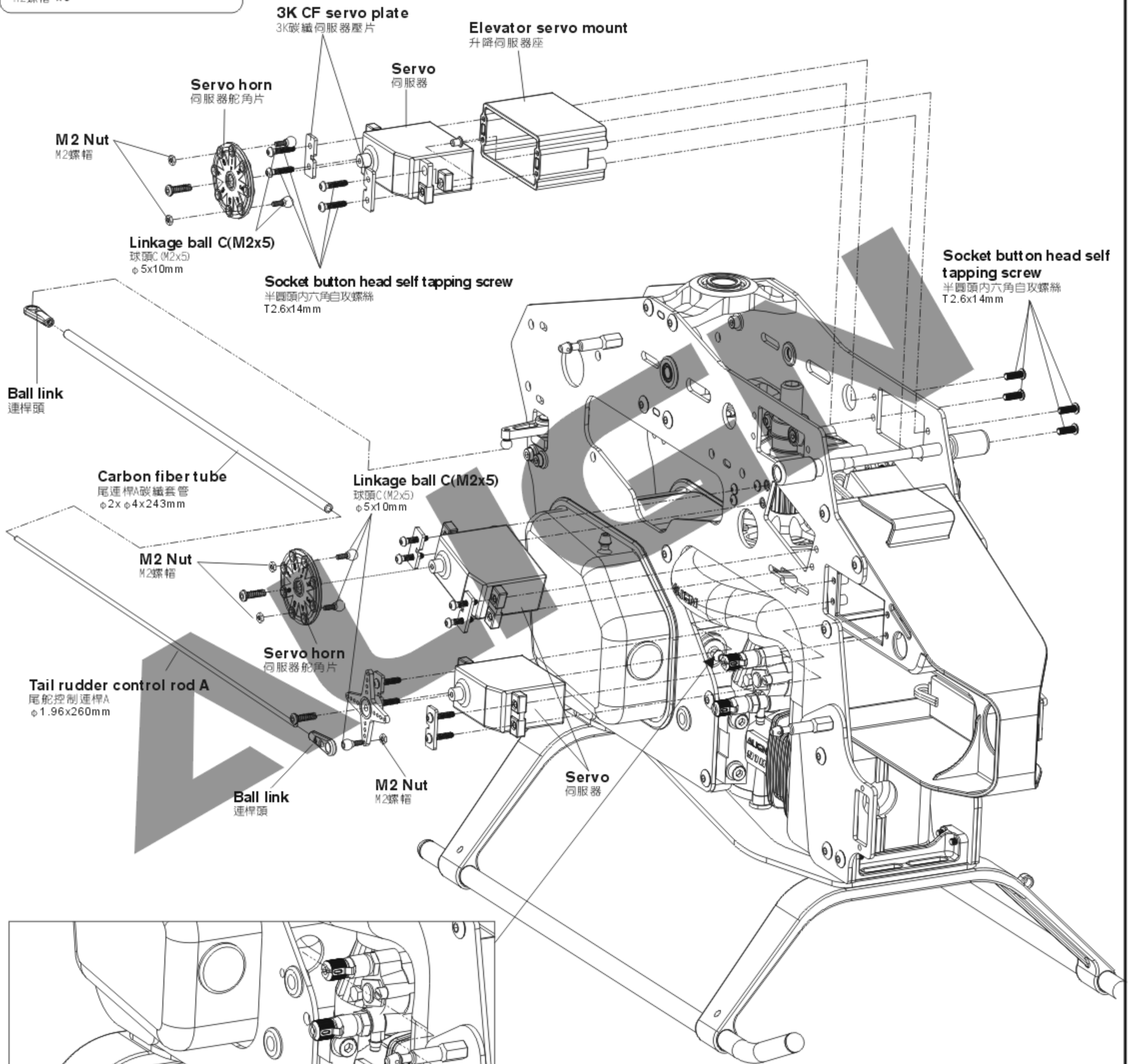

700NZ4

 
Linkage ball C (M2x5)
 球頭C (M2x5) (φ5x10mm) x 4

 
Socket button head self tapping screw
 半圓頭內六角自攻螺絲(T2.6x14mm) x 8

 
M2 Nut
 M2螺帽 x 4

Recommend sanding the marked position as below illustration with a waterproof abrasive paper (#800-1000) to avoid the wires of electric parts to be cut.
 建議於下圖色塊標示處，使用#800-1000水砂紙打磨，可防止電子設備電線被割破。

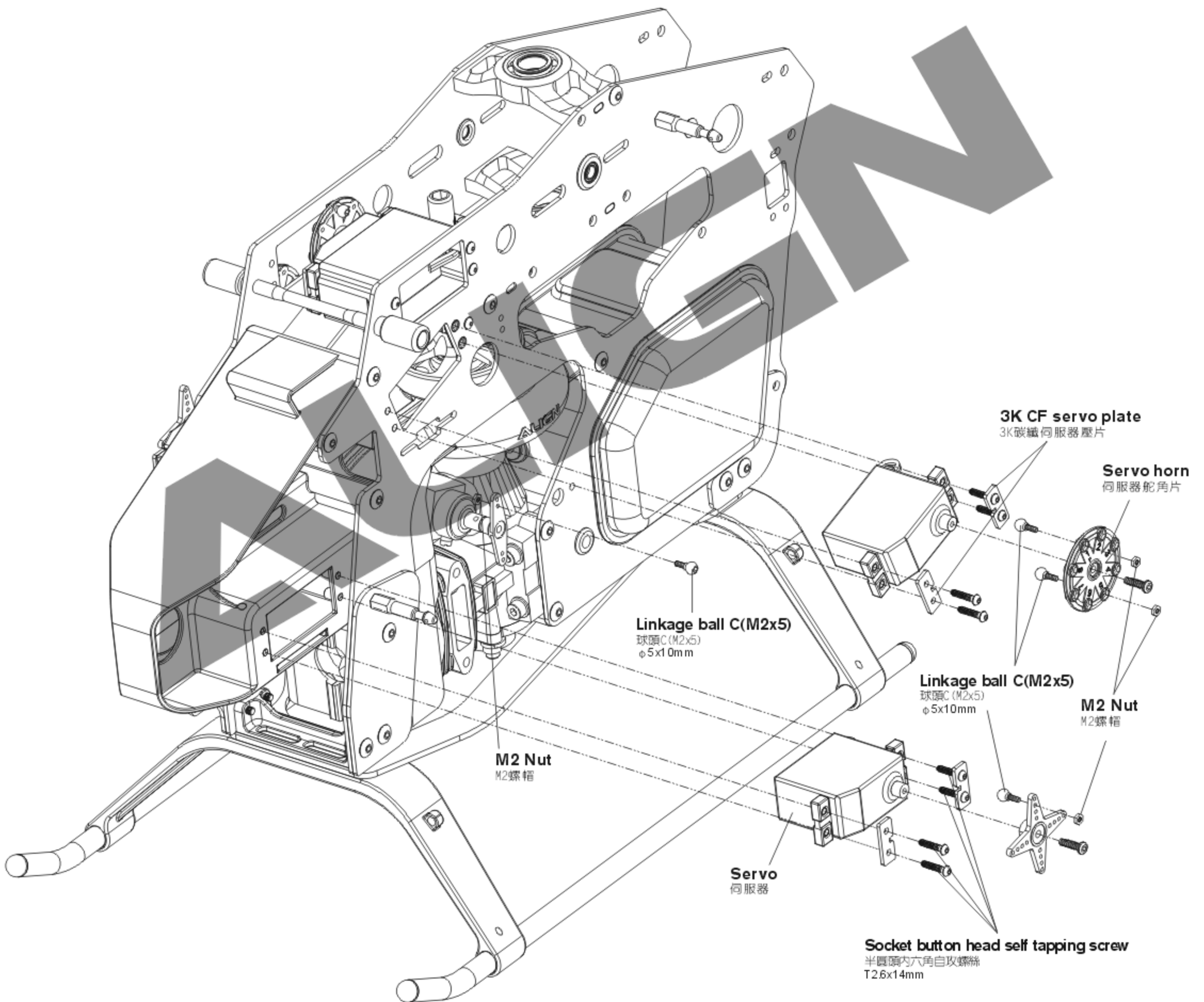
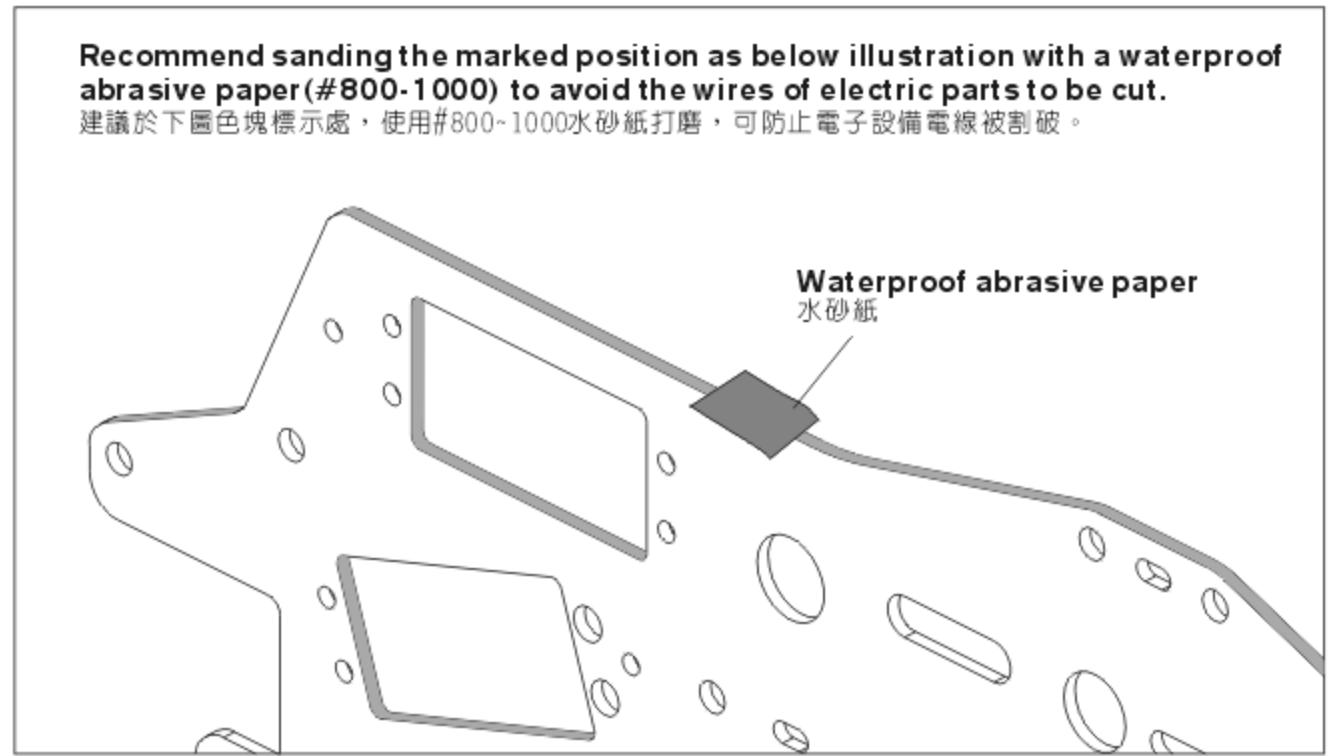

700NB1



Bearing MR95ZZ
MR95ZZ軸承(φ5xφ9x3mm) x 4



Socket button head screw
半圓頭內六角螺絲(M3x6mm) x 2



Socket button head screw
半圓頭內六角螺絲(M3x8mm) x 2



Bearing F683ZZ
F683ZZ軸承(φ3xφ7x3mm) x 2

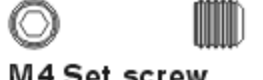

M4 Set screw
M4止洩螺絲(M4x4mm) x 1



Control shaft collar
運動桿套圈(φ5xφ7.5x3mm) x 2

700NB1A



Linkage ball C(M3x3.5)
球頭C(M3x3.5)(φ5x8.5mm) x 8



Socket screw
圓頭內六角螺絲(M3x12mm) x 1



Washer
華司(φ3xφ5.5x0.3mm) x 2



Elevator ball link
升降臂連桿頭

700NZ2A



Ball link
連桿頭 x 12

700NZ2

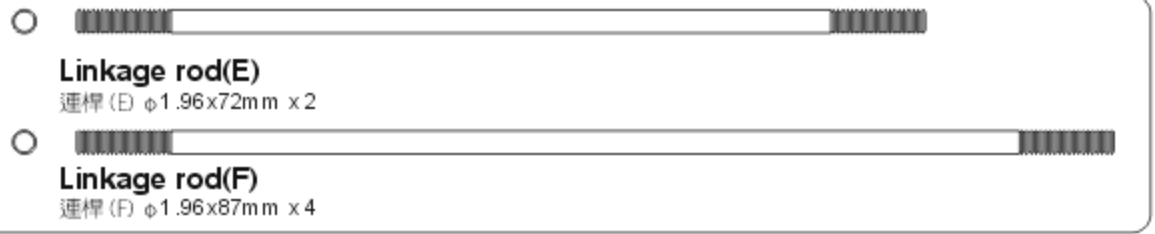

Linkage rod(E)
連桿(E) φ1.96x72mm x 2

Linkage rod(F)
連桿(F) φ1.96x87mm x 4

Linkage rod(E)
Approx. 92mm x 2
連桿(E)約92mm x 2

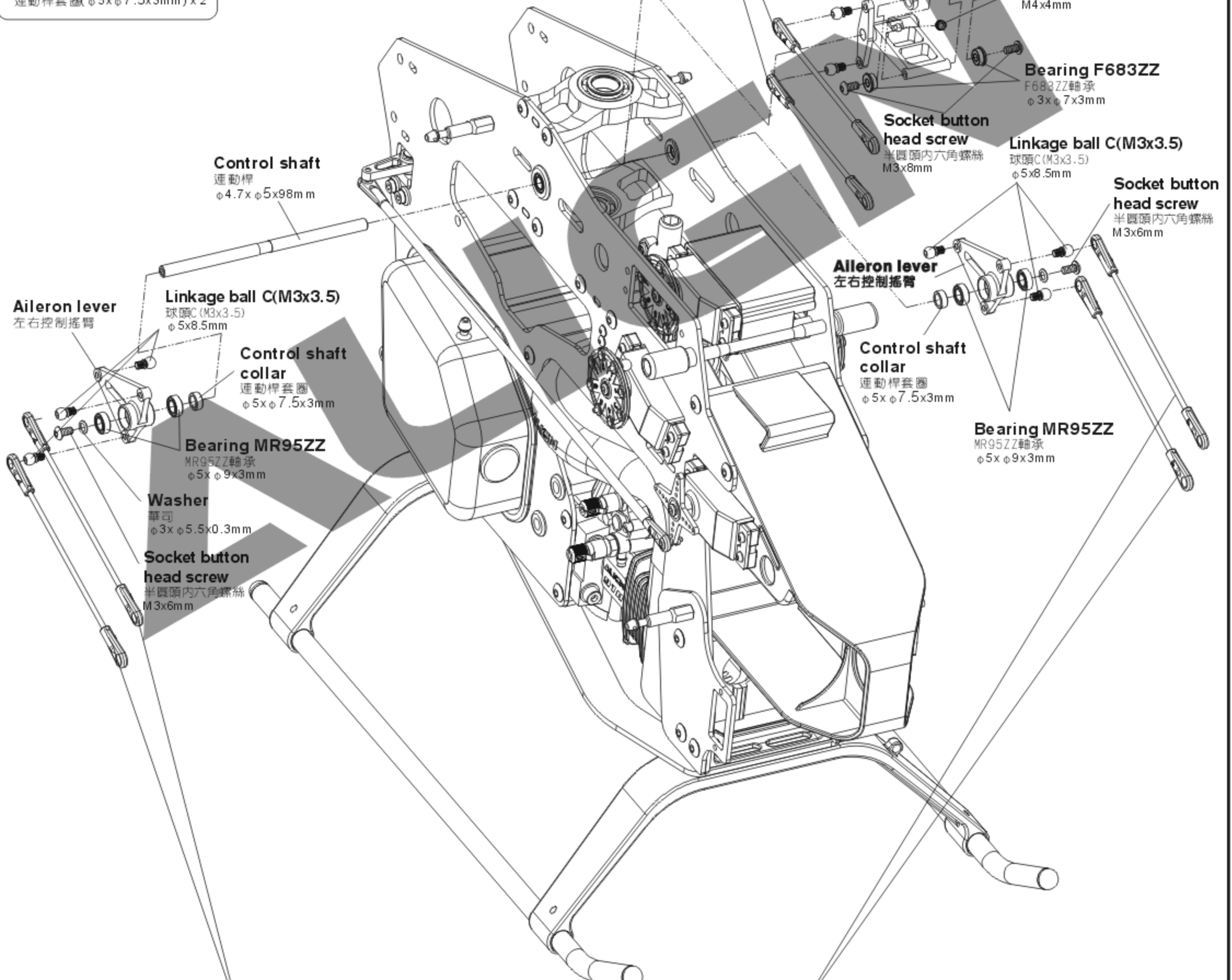

Linkage rod(F)
Approx. 108mm x 4
連桿(F)約108mm x 4



Fan cover fixing Tip
風扇罩固定要領

Before fixing the engine fan cover, please use a starter to rotate the fan and move the fan cover. This is to make sure no any interference, and then secure the fan cover with a fixing screw.

鎖緊固定引擎散熱風罩前，請先使用啟動棒轉動風扇，並移動風扇罩，確認在風扇無碰觸風扇罩後才鎖緊風扇罩固定螺絲。

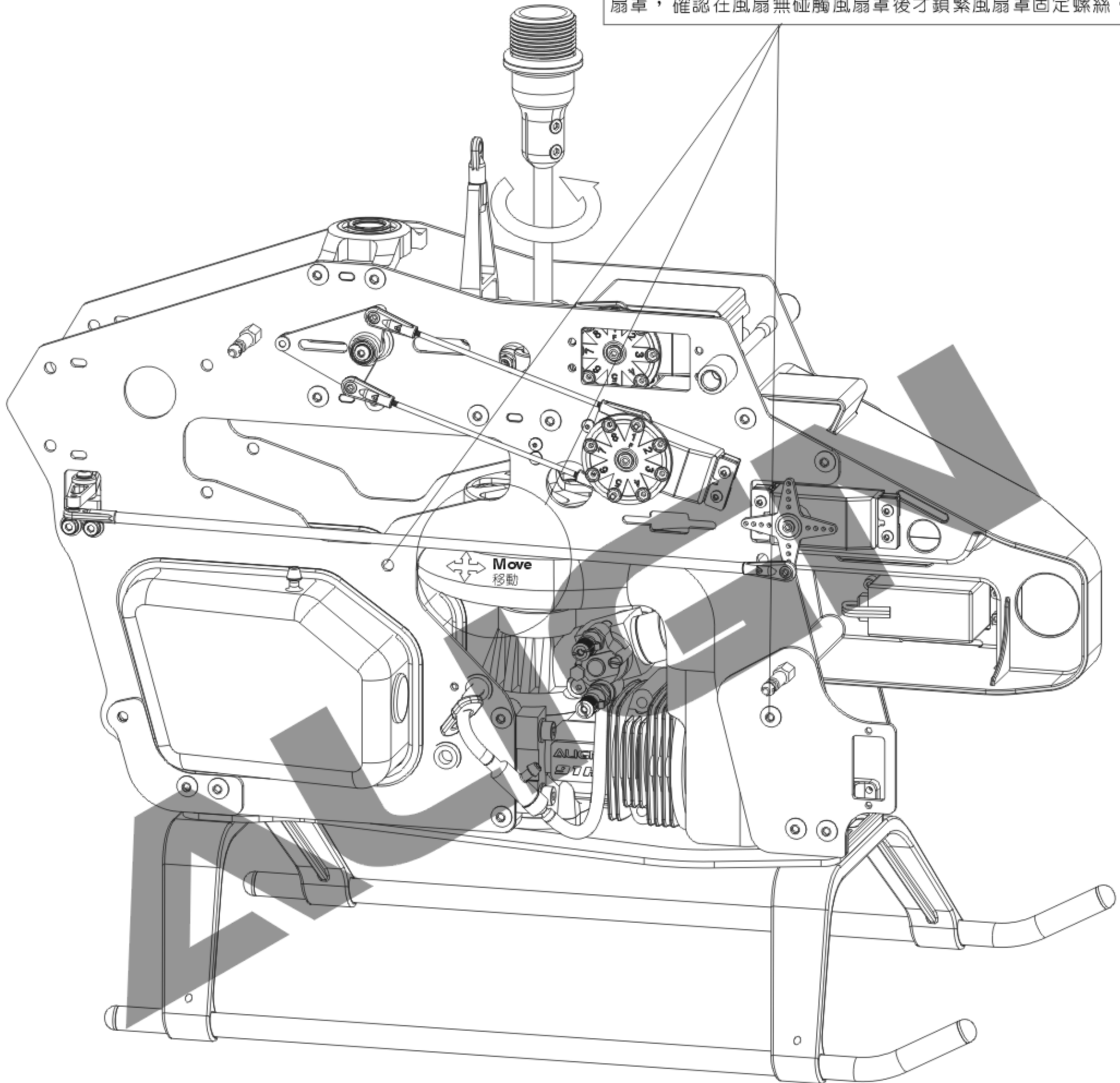

FUEL TUBE CLIP B ILLUSTRATION 油管夾片B使用說明

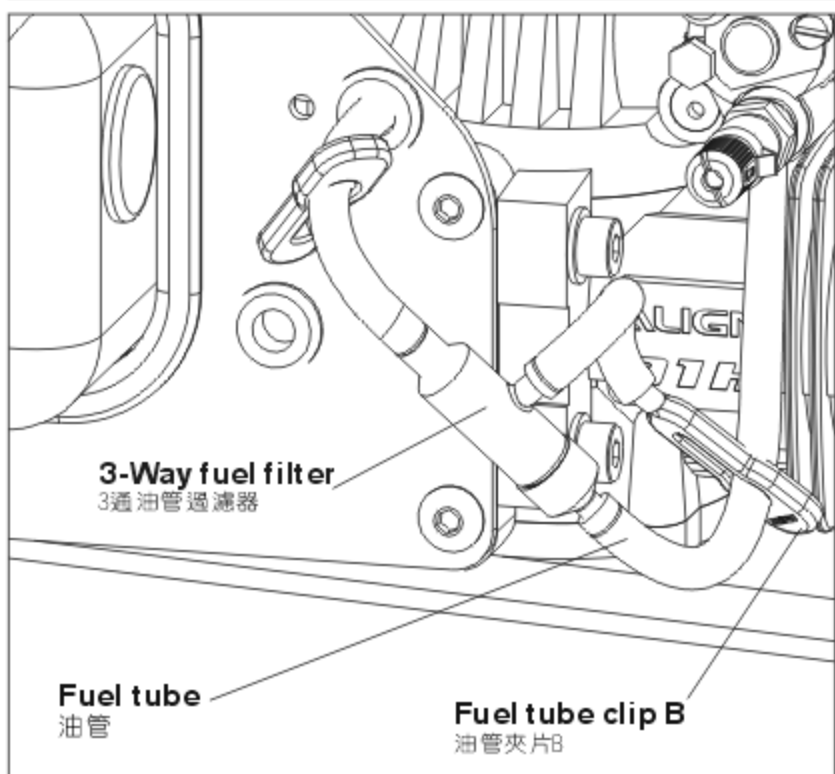

FUEL TUBE CLIP ILLUSTRATION 油管夾片使用方法

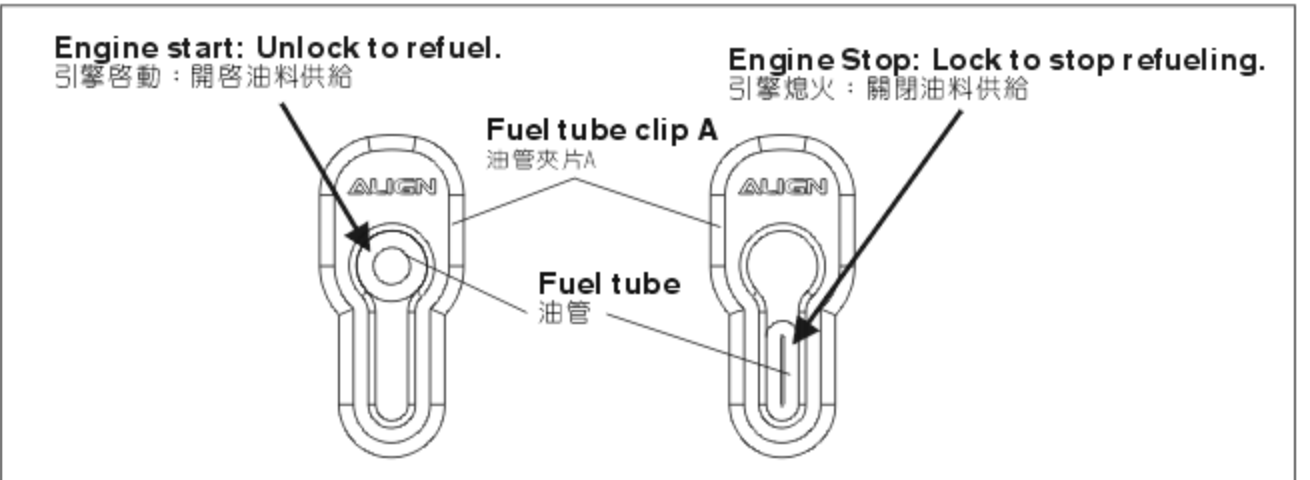

700NT1

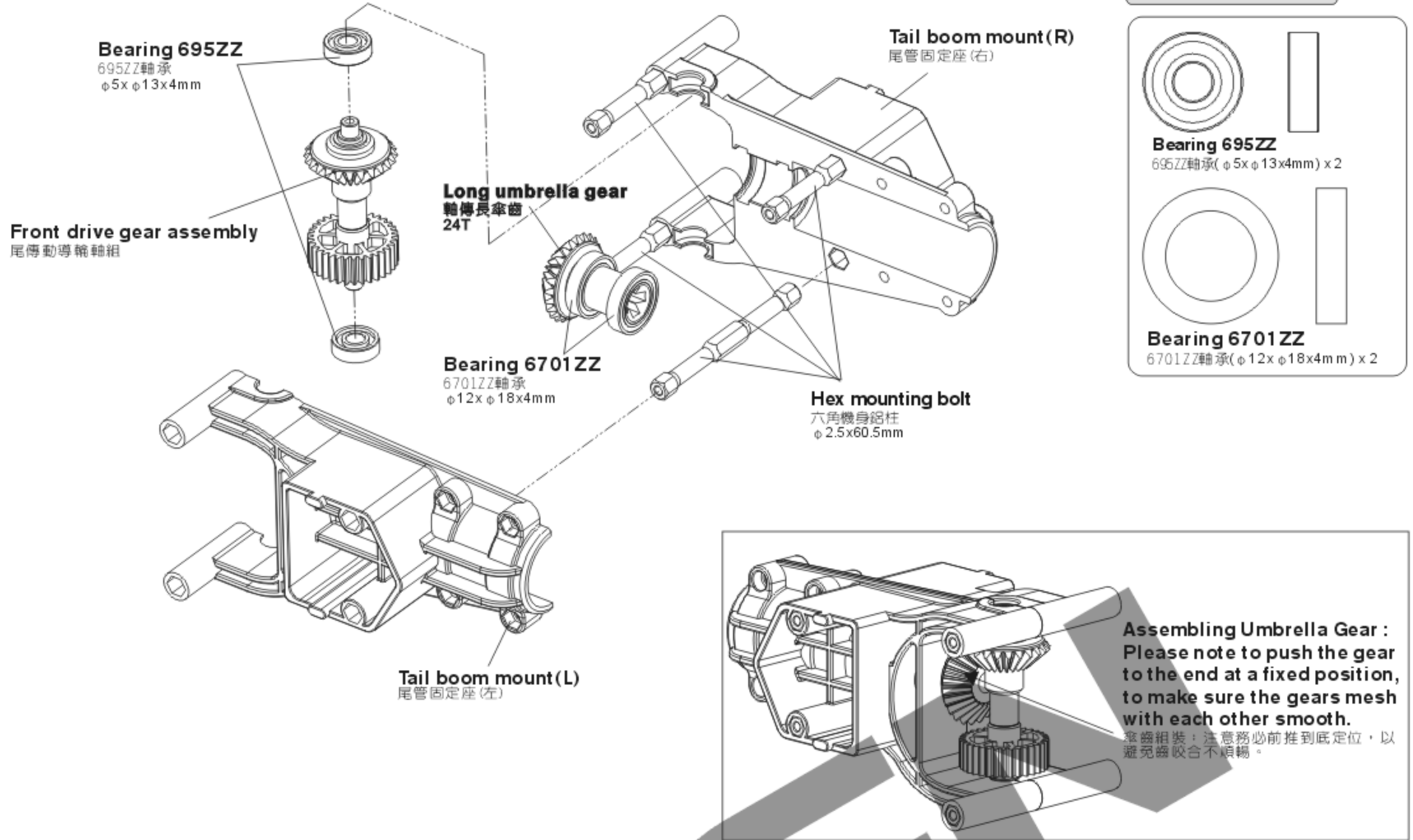

700NT2A

Apply a little amount of T43 thread lock when fixing a metal part.
螺絲鎖劑於金屬件請使用適量T43(螺絲膠)

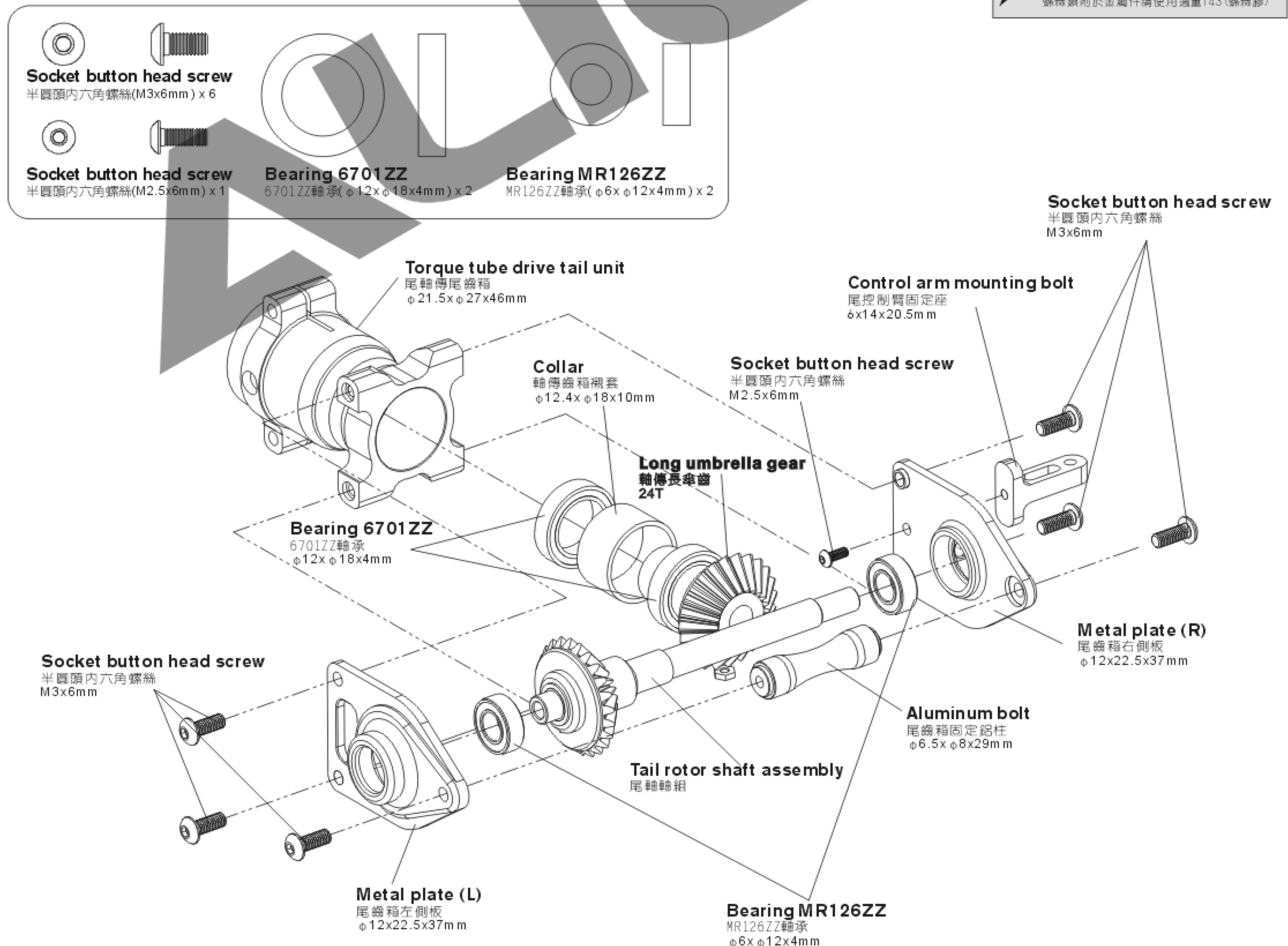

700NT2B



700NT2C

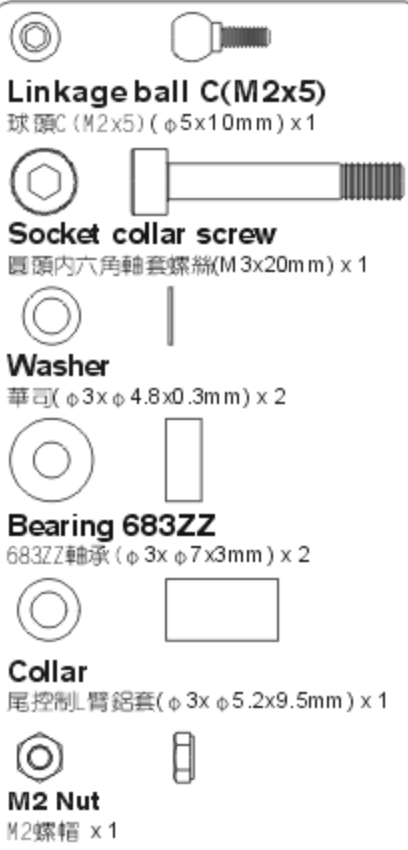

700NT2D



Apply a little amount of T43 thread lock when fixing a metal part.
螺絲鎖附於金屬件請使用適量T43 (螺絲膠)

CAUTION
注意

Aim tail rotor hub at the concave of tail rotor shaft and fix it, please apply a little glue on the set screw.
尾旋翼T型座瞄準尾橫軸的凹刻並鎖上，請確認止洩螺絲上膠。

Assembling Umbrella Gear : Please note to push the gear to the end at a fixed position, to make sure the gears mesh with each other smooth.
傘齒組裝：注意務必前推到底定位，以避免齒咬合不順暢。

CAUTION
注意

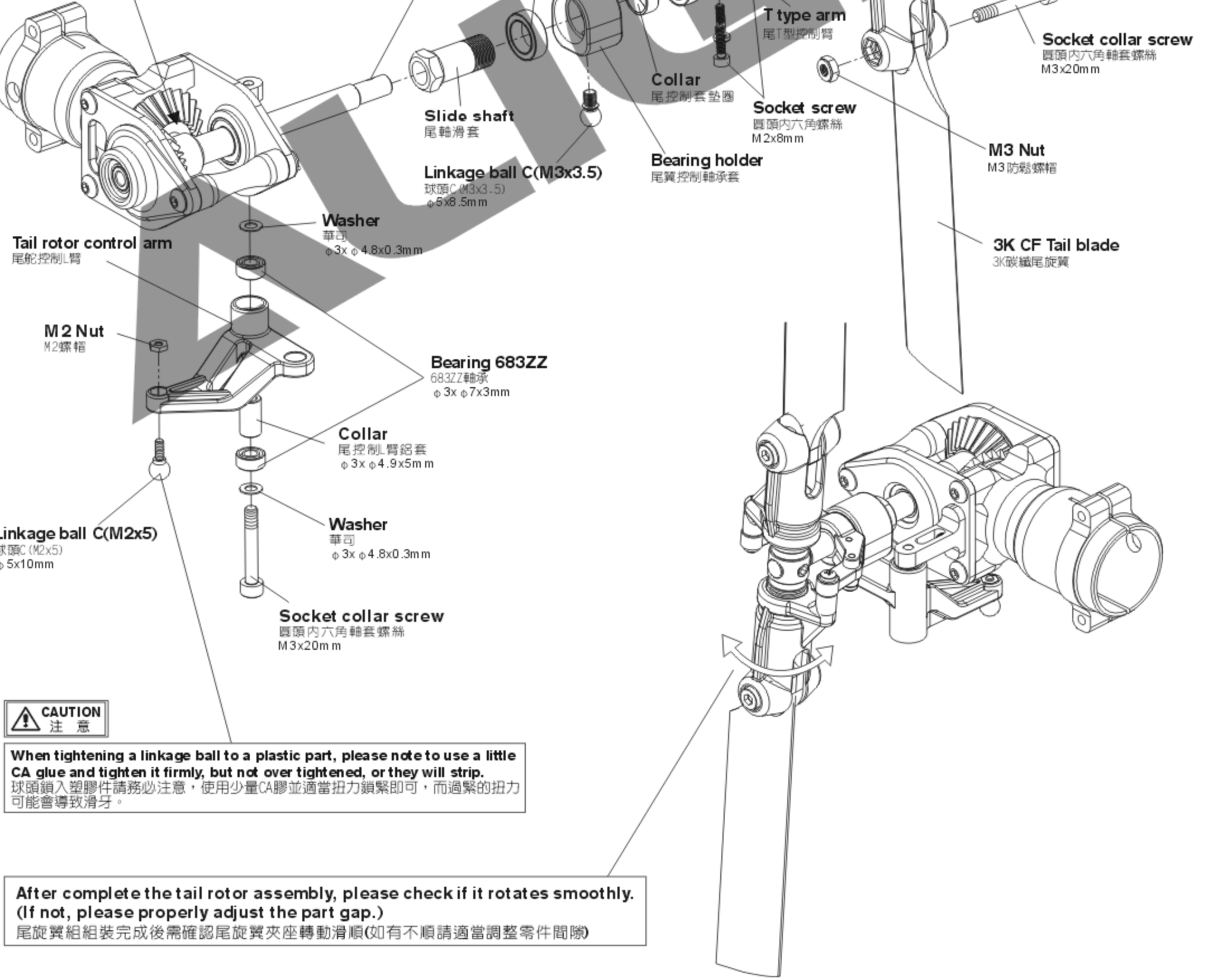
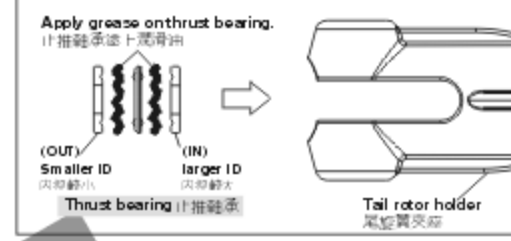

CAUTION
注意

When tightening a linkage ball to a plastic part, please note to use a little CA glue and tighten it firmly, but not over tightened, or they will strip.
球頭鎖入塑膠件請務必注意，使用少量CA膠並適當扭力鎖緊即可，而過緊的扭力可能會導致滑牙。

After complete the tail rotor assembly, please check if it rotates smoothly. (If not, please properly adjust the part gap.)
尾旋翼組裝完成後需確認尾旋翼夾座轉動滑順(如有不順請適當調整零件間隙)

Already assembled by factory,
please note to check again.
已組裝完成，請務必自行再確認。

Socket screw
圓頭內六角螺絲
M3x14mm

When assembling into the tail boom, please
apply some oil on the surface, to make it smooth
during the assembling and keep it vertical with
the torque tube for smooth rotation.
插入尾管內時，外表抹些潤滑油，以確保平順壓入尾管中並與尾
傳動軸保持垂直，讓尾軸傳動順暢。

When assembling
the tail boom,
please aim at the
fixing hole $\phi 5$.
裝入尾管時請注意孔
對準尾管 $\phi 5$ 固定孔

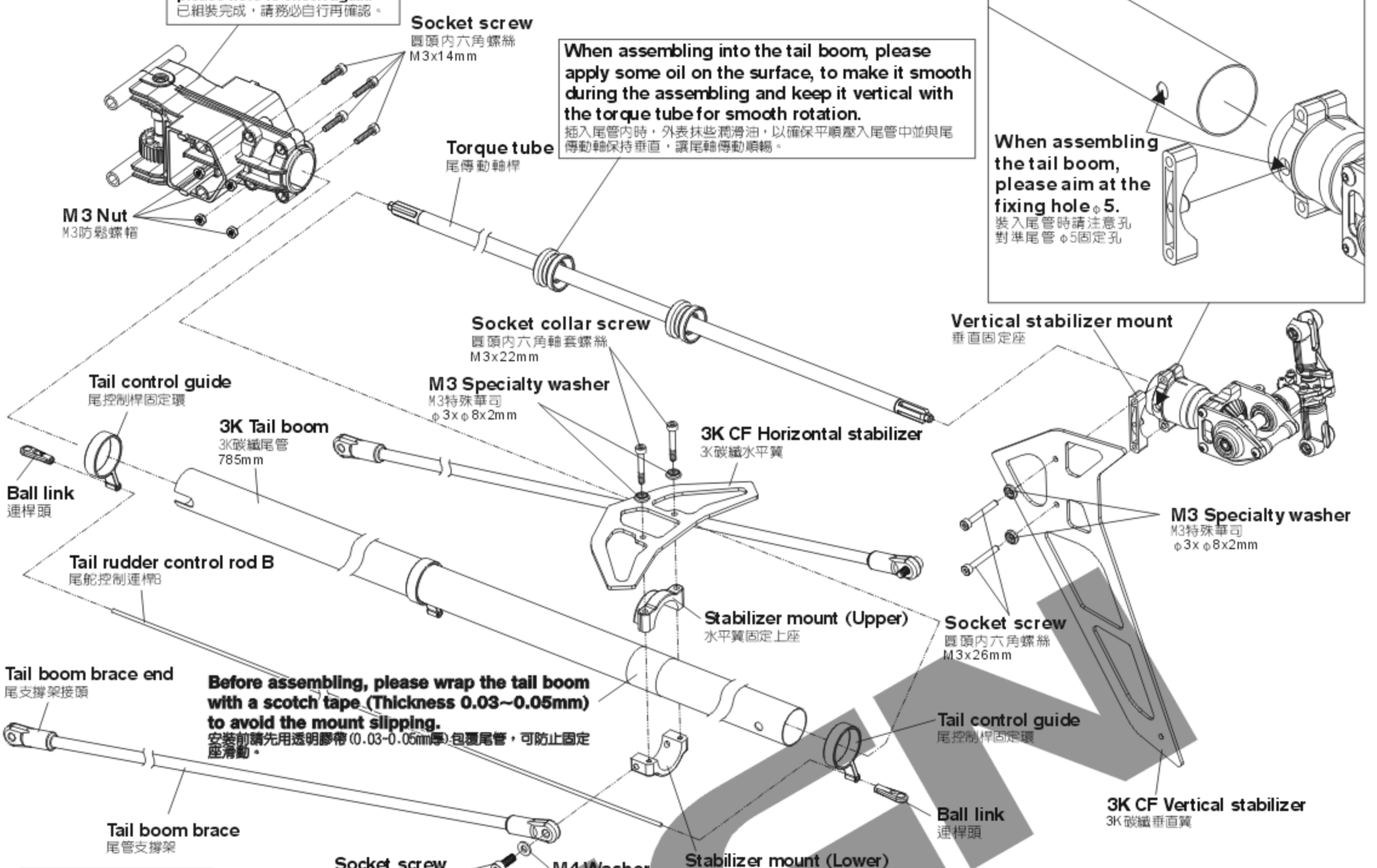

Before assembling, please wrap the tail boom
with a scotch tape (Thickness 0.03~0.05mm)
to avoid the mount slipping.
安裝前請先用透明膠帶(0.03~0.05mm厚)包覆尾管，可防止固定
座滑動。

700NT1A

- Socket screw
圓頭內六角螺絲(M3x14mm) x 4
- M3 Nut
M3防鬆螺帽 x 4

700NT2A

- Socket screw
圓頭內六角螺絲(M3x26mm) x 2
- M3 Specialty washer
M3特殊華司($\phi 3 \times \phi 8 \times 2 \text{mm}$) x 2

700NT2EA

- Socket screw
圓頭內六角螺絲(M4x12mm) x 2
- Socket collar screw
圓頭內六角軸套螺絲(M3x22mm) x 2
- M3 Specialty washer
M3特殊華司($\phi 3 \times \phi 8 \times 2 \text{mm}$) x 2
- M4 Washer
M4華司($\phi 4 \times \phi 10 \times 1 \text{mm}$) x 2

Tip to fix the torque tube 傳動軸軸承固定位要領

Please apply some CA glue to fix MR148 bearing on the torque tube, avoid CA glue adhering to the
dust cover or it may cause the bearing stuck. When assembling into the tail boom, please apply
some oil on the bearing holder and press the holder into the tail boom horizontally.
請以少量CA將MR148軸承固定於尾傳動軸上，避免CA沾到軸承的防塵蓋而導致軸承卡死，插入尾管內時，尾傳動軸承墊圈外表抹些
潤滑油，將尾傳動軸承墊圈平行壓入尾管中不可歪斜。

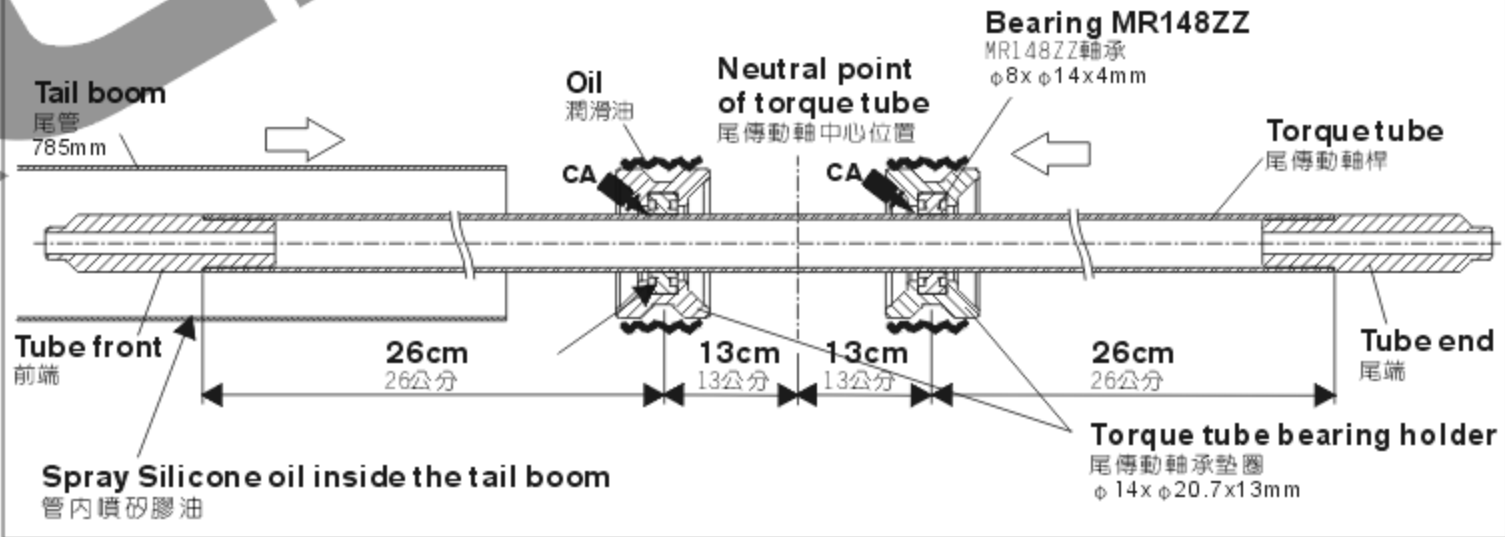

700NT3BA

- Ball link
連桿頭 x 2

700NT1A



700NZ2



700NZ2A



700NB1

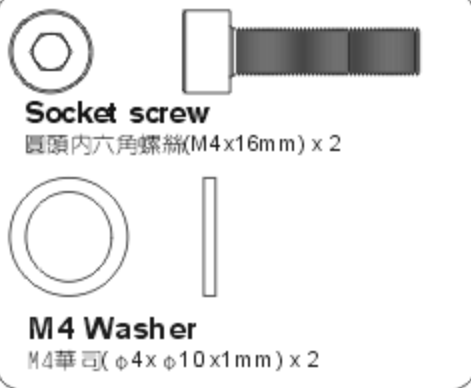

Please assemble the G linkage rods inside the servo horns to avoid any interference caused by the canopy.
G連桿請裝於伺服臂內側確保動作時不碰觸機頭罩

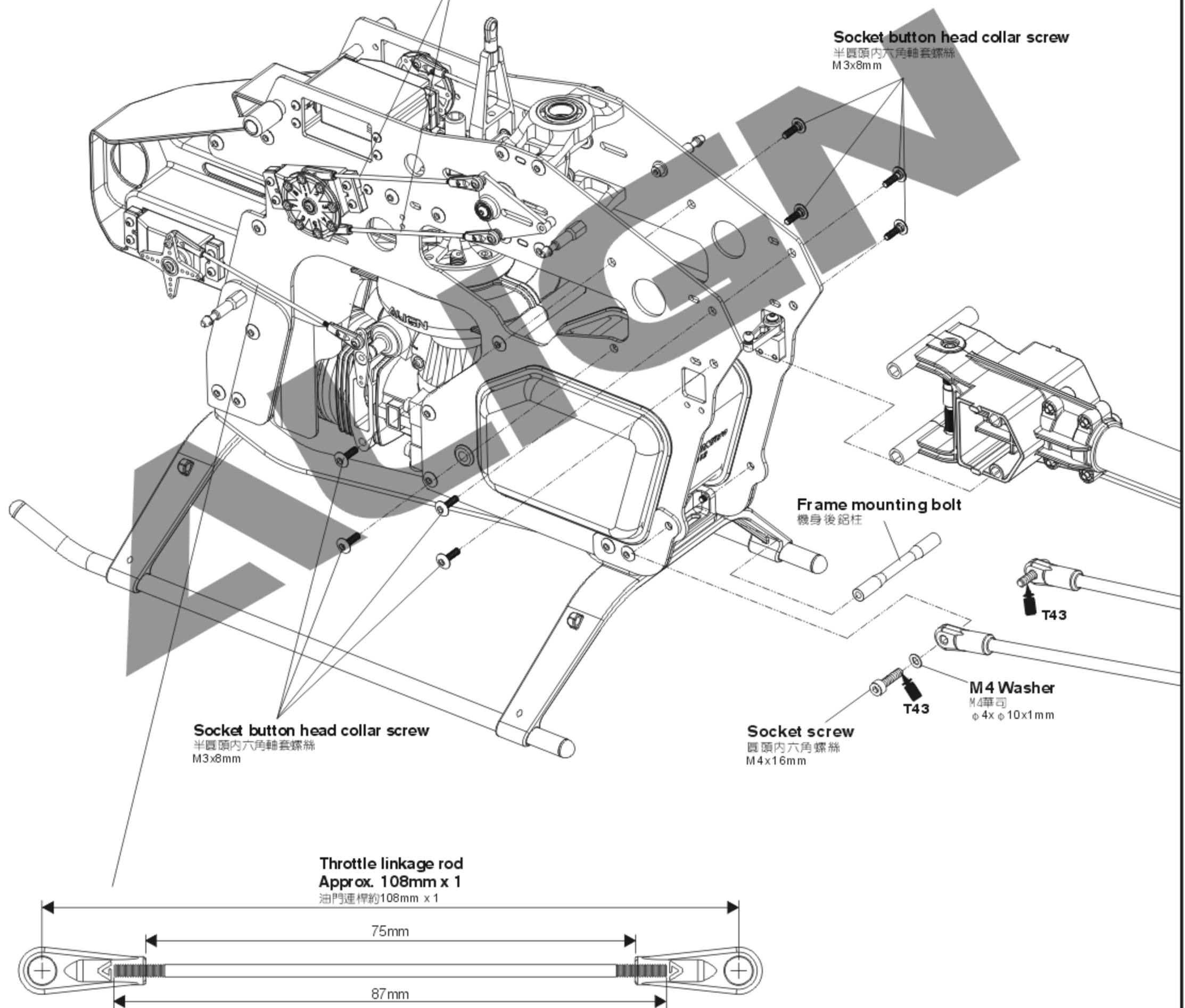

When tightening a screw to a plastic part, please tighten it firmly, but not over tightened, or they will strip.
螺絲鎖入塑膠件請務必注意，適當扭力鎖緊即可，而過緊的扭力可能會導致滑牙。

700NB3

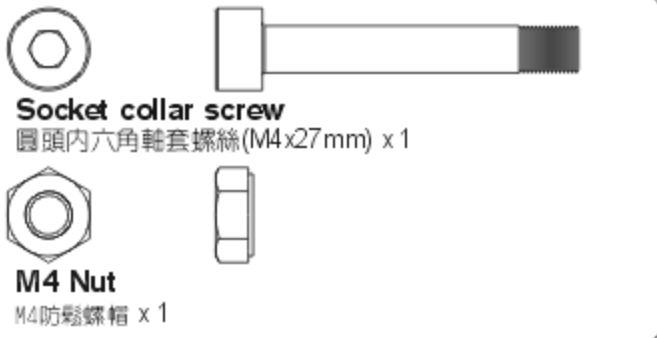

When tightening the main blade fixing screw, please tighten it firmly, but not over tighten, or it may cause the damage of main blade holder and result in danger.
鎖緊主旋翼螺絲須注意適當緊度即可，過緊可能導致主旋翼夾座受損，飛行意外發生。

Socket collar screw
圓頭內六角軸套螺絲
M5x32mm

700NH1A

700NH4A

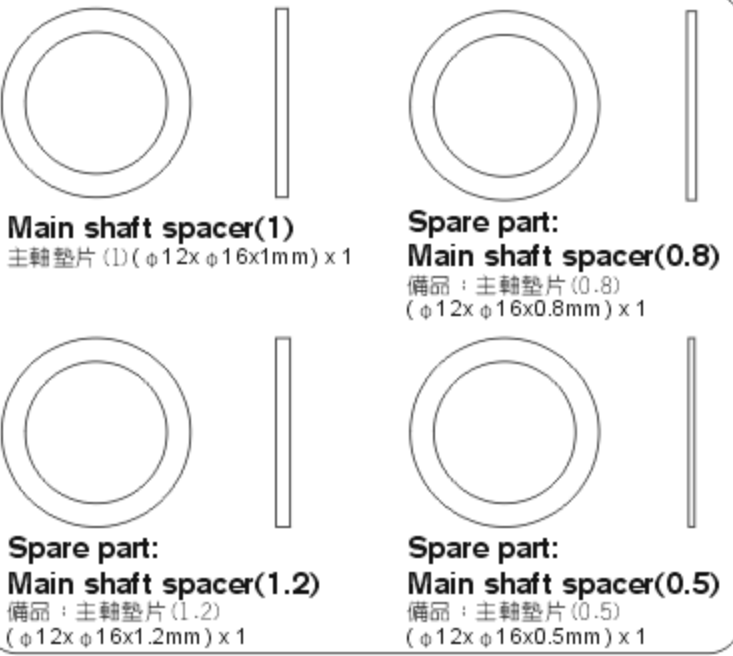

Option equipment: 690~710 Blade
另購：690-710主旋翼

M5 Nut
M5防鬆螺帽

700NZ2A



700NZ2



Linkage rod(D)
Approx. 67.2mm x 2
連桿(D)約67.2mm x 2

44mm
34.2mm

Standard Equipment: Main shaft spacer(1)
標準品：主軸墊片(1)
φ12xφ16x1mm

Spare part: Main shaft spacer(1.2)
Main shaft spacer(0.8)
Main shaft spacer(0.5)
備品：主軸墊片(1.2) φ12xφ16x1.2mm
主軸墊片(0.8) φ12xφ16x0.8mm
主軸墊片(0.5) φ12xφ16x0.5mm

Main drive gear set
主齒輪組

M4 Nut
M4防鬆螺帽

Socket screw
圓頭內六角軸套螺絲
M4x27mm

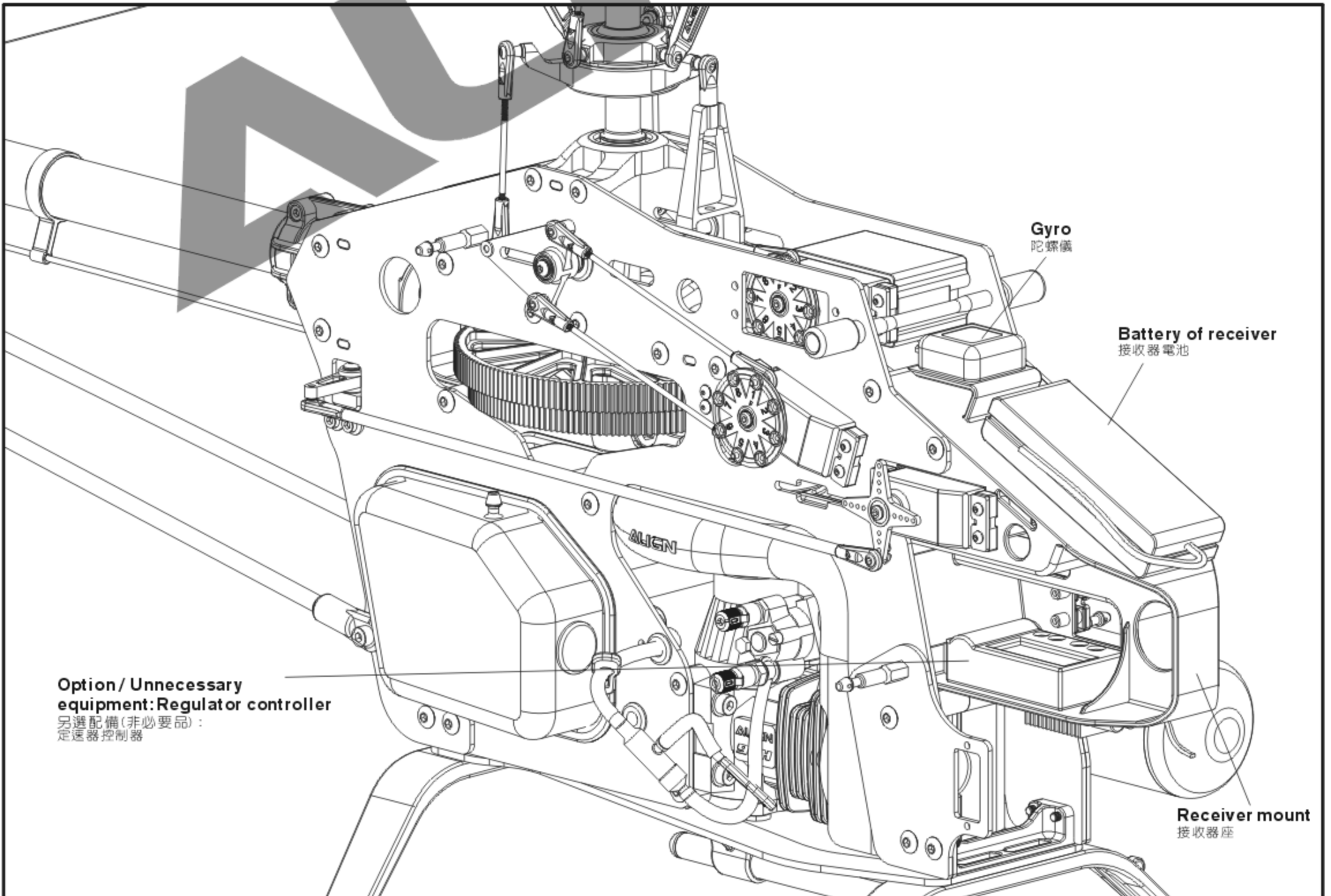
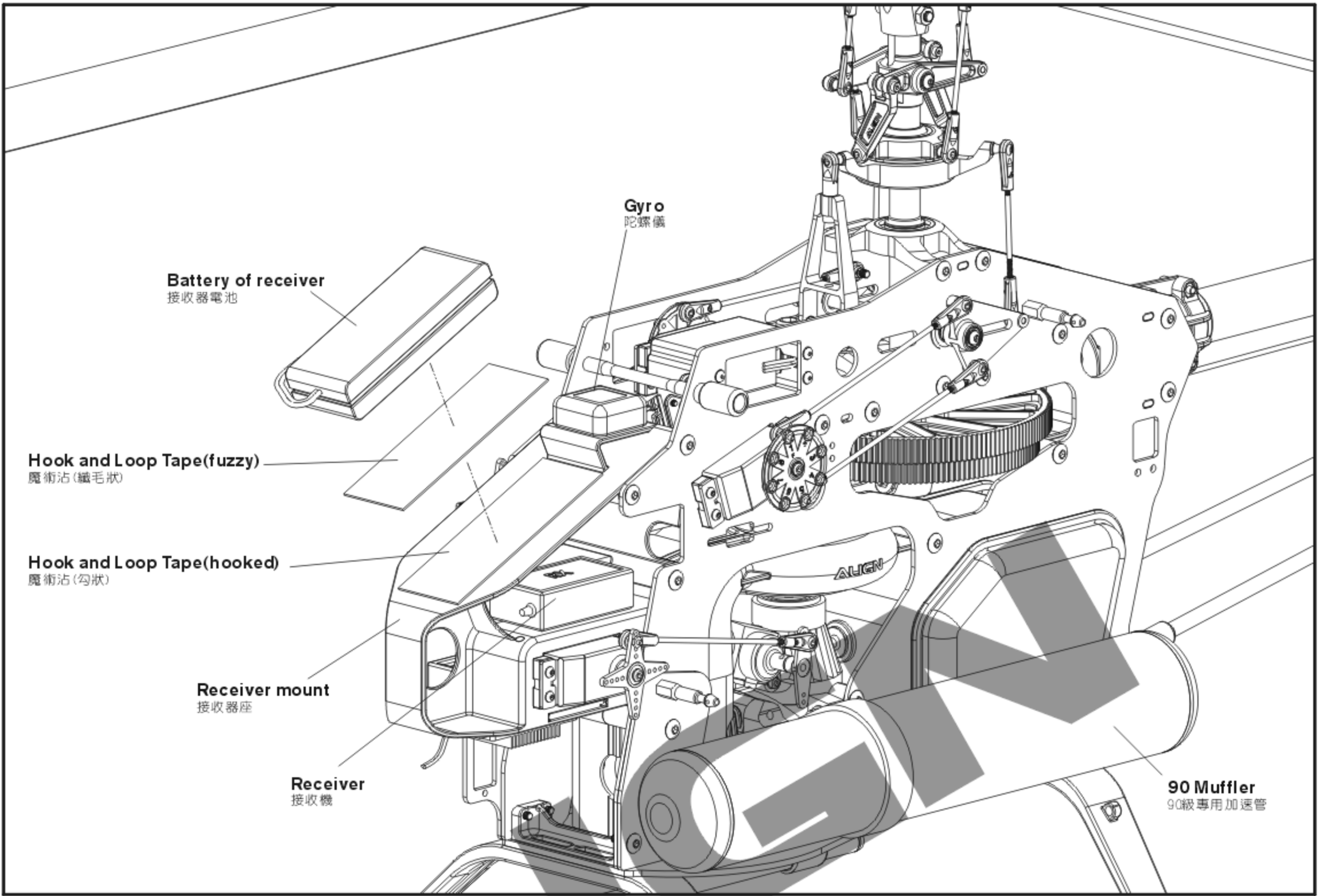

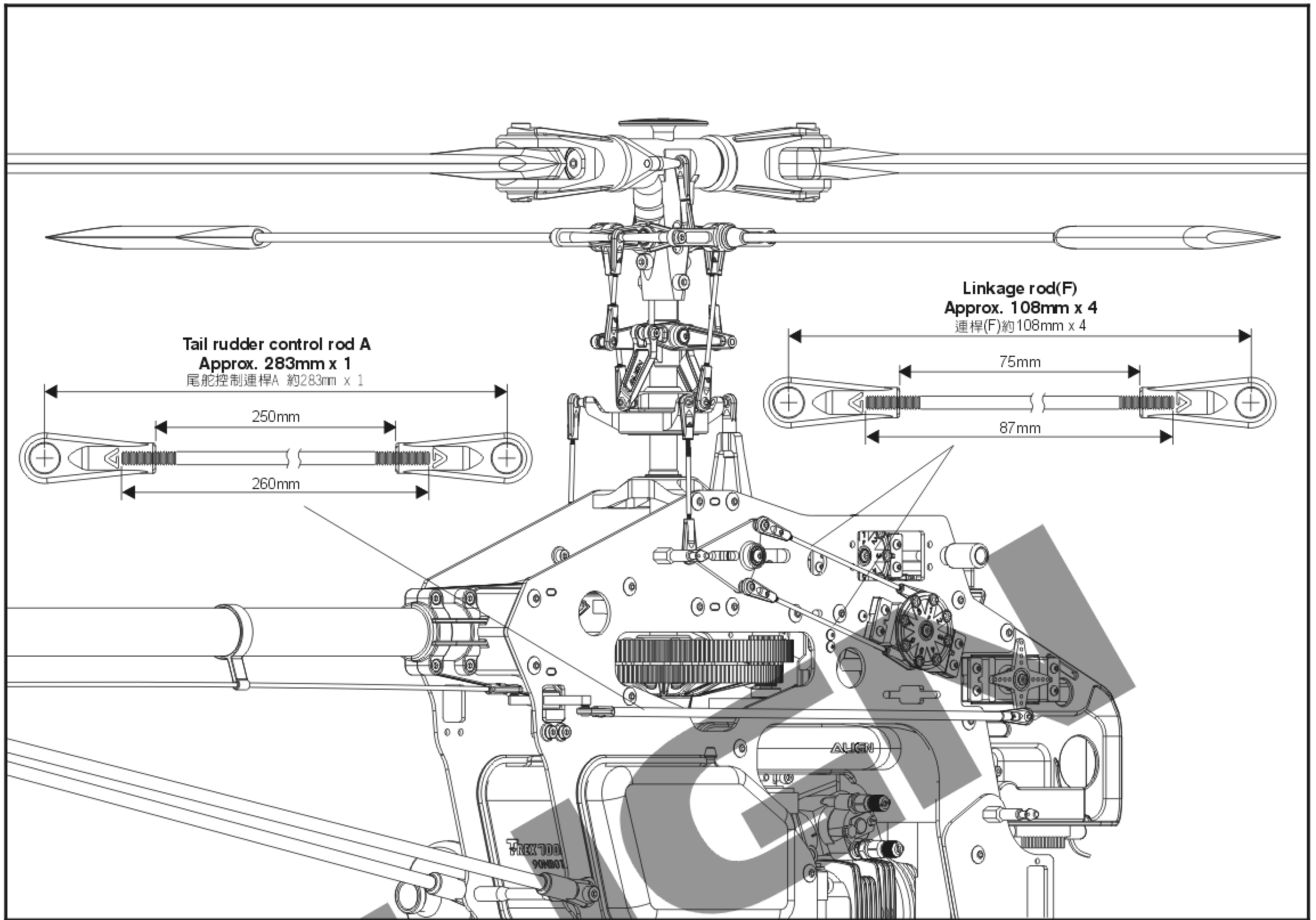

8.CANOPY ASSEMBLY 機頭罩安裝

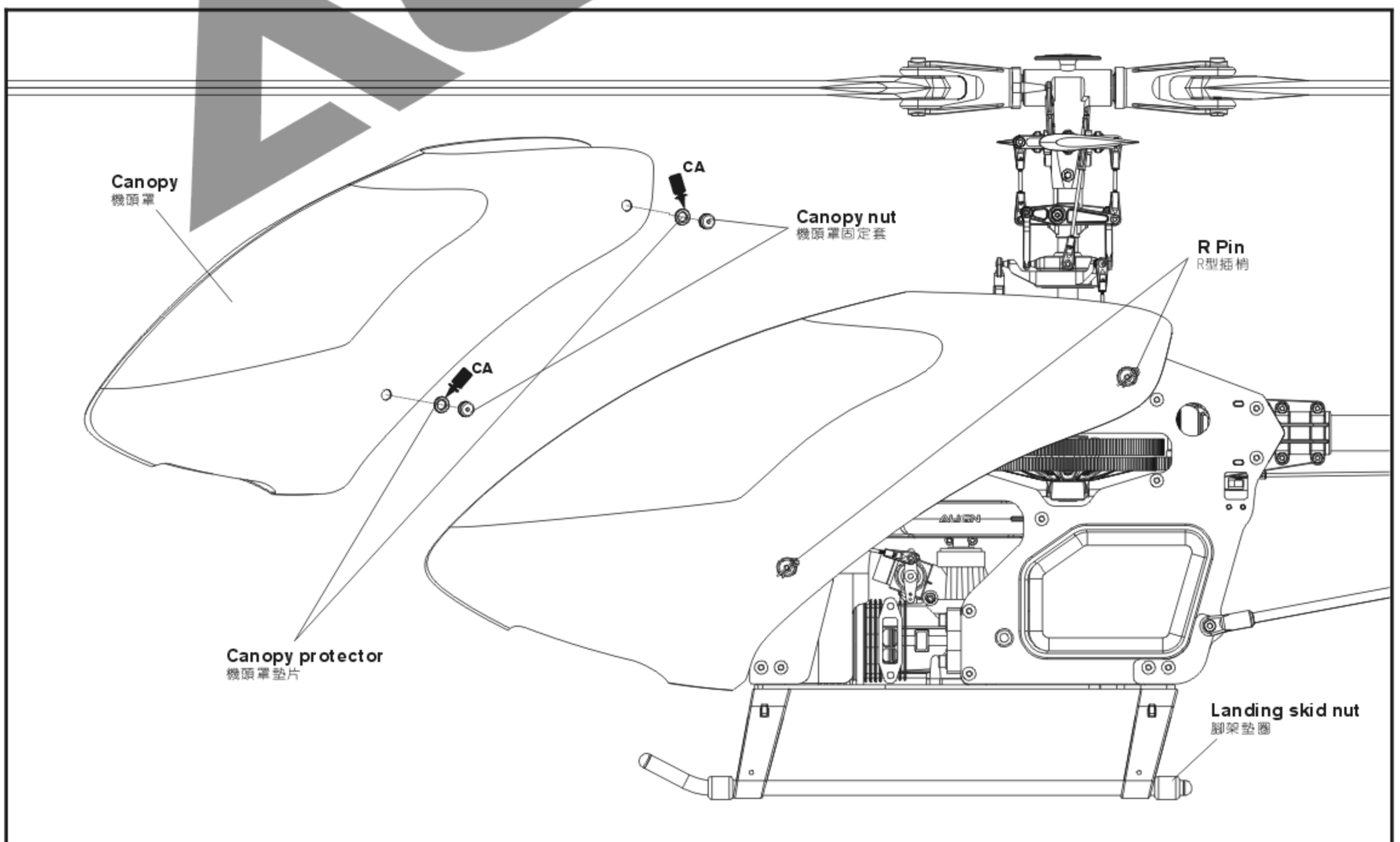

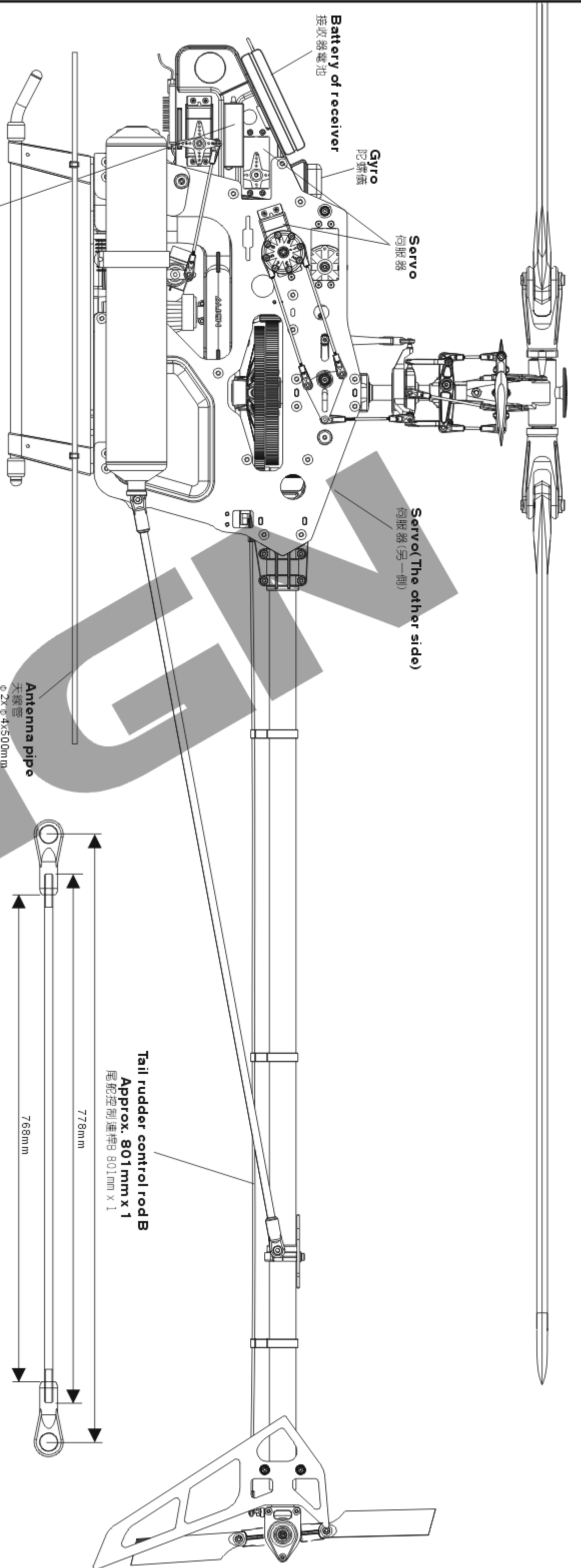

Option / Unnecessary equipment: Regulator controller
另選配備(非必要品): 定速器控制器

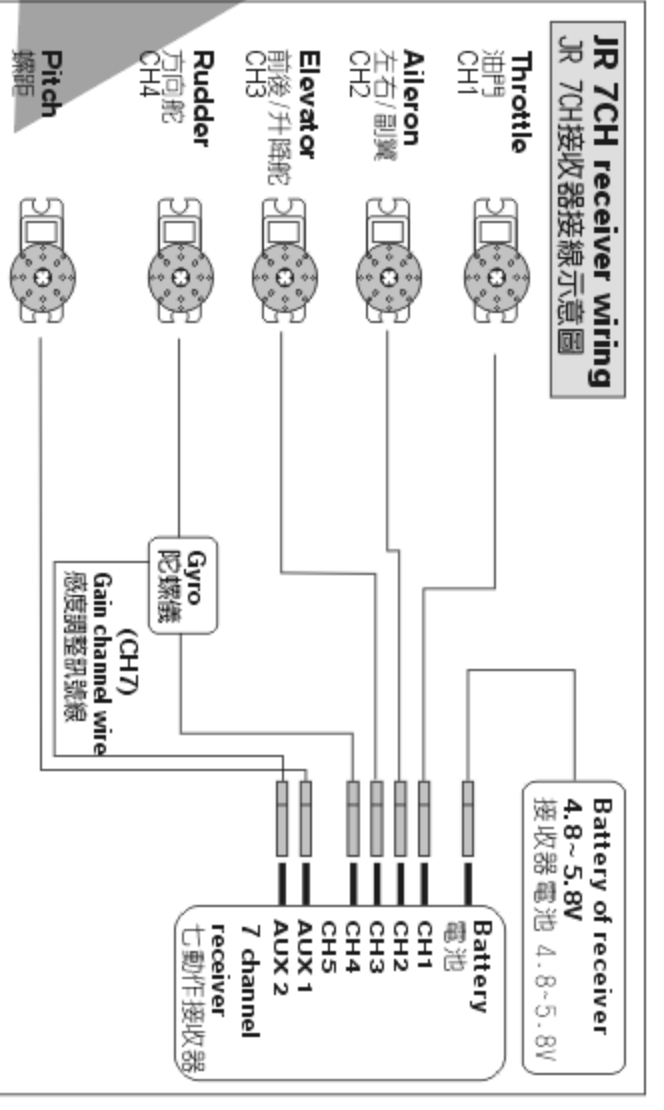
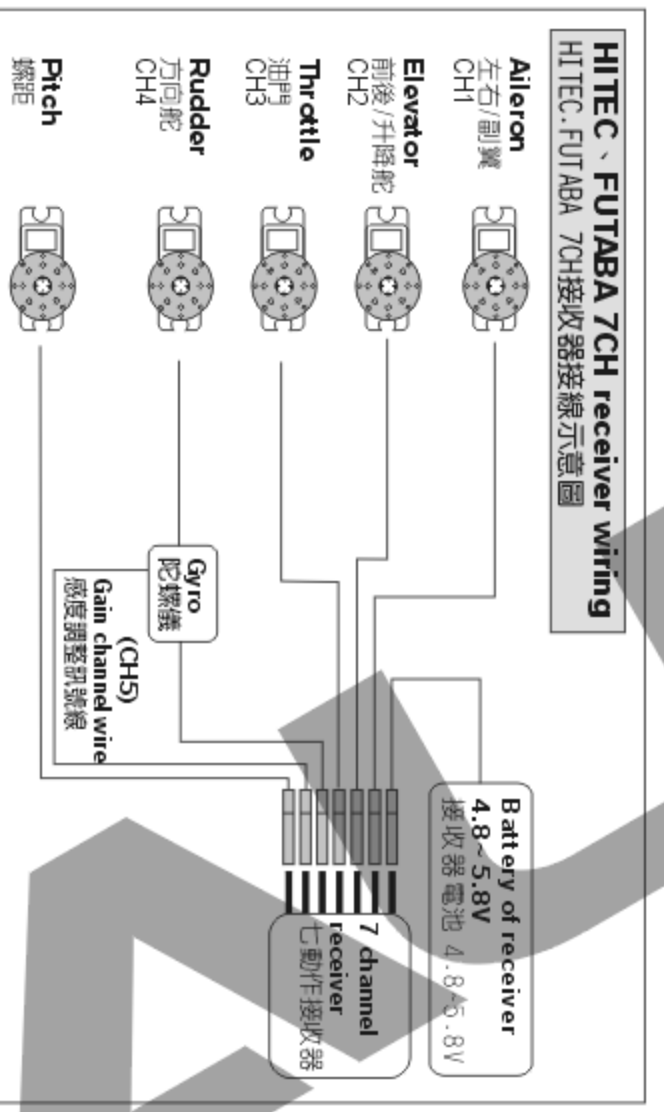

7-Channel Receiver is adequate for the requirements of the T-REX heli. You will need the following channels at a minimum: Throttle, Rudder, Elevator, Aileron, and especially Pitch(CH6) and Gyro(CH5) controls. 七動作的接收器已足夠應對T-REX遙控直升機的頻道需求，除了油門、方向舵、升降舵、副翼等基本動作外，亦可以對應具備感度調整的陀螺儀(CH5)與螺距(CH6)。

7-Channel Receiver is adequate for the requirements of the T-REX heli. You will need the following channels at a minimum: Throttle, Rudder, Elevator, Aileron, and especially Pitch(AUX 1) and Gyro(AUX 2) controls. 七動作的接收器已足夠應對T-REX遙控直升機的頻道需求，除了油門、方向舵、升降舵、副翼等基本動作外，亦可以對應具備感度調整的陀螺儀(AUX 2)與螺距(AUX 1)。

To set this option is to turn on the transmitter and connect to BEC power.
此項設定只要開啓發射器，接上BEC電源即可進行操作。

JR Transmitter/Servo
JR遙控器對應伺服器關係

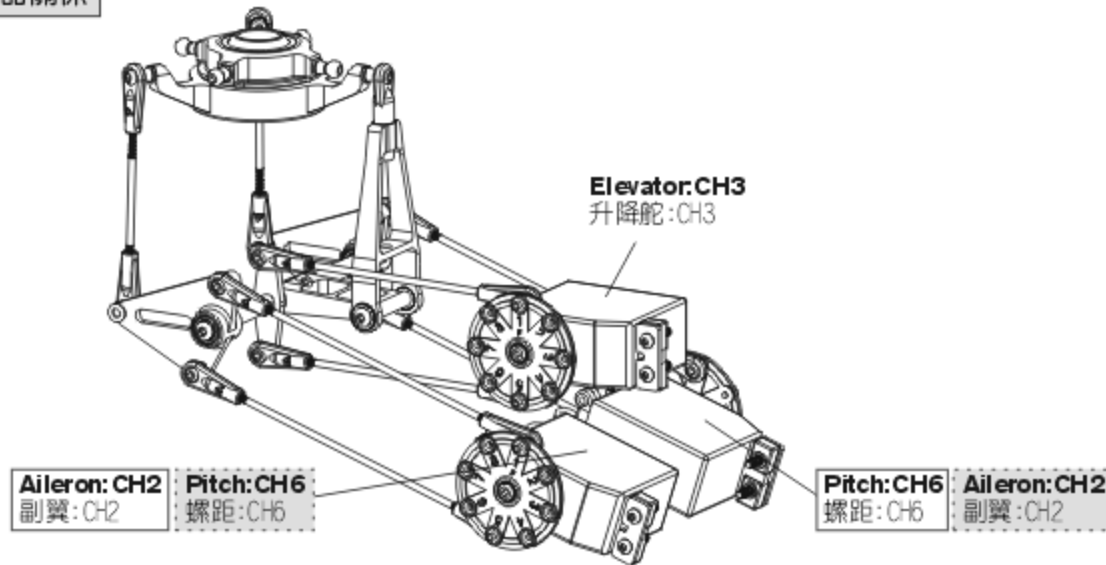

Positions of CH2、CH6 are exchangeable, After assembling as photo (Note: Set the transmitter under CCPM 120 degrees mode), pull throttle stick (pitch) upward. If one swashplate servo (or two servos) moves downward, adjust reverse switch (REV) on the transmitter to make it moves upward. If three servo move downward, adjust the travel value (+) of SWASH CH6 on the transmitter to make them move upward. When the actions of Aileron and Elevator are opposite, adjust travel values of SWASH CH2 and Ch3.

CH2、CH6可互換配置，依圖連結後(注意:遙控器須設定於CCPM 120°十字盤模式)，將油門搖桿(Pitch)往上推，若十字盤伺服器有1個或2個往下移時，請調整搖控器的反轉開關(REV)使伺服器往上，若3個伺服器同時往下移時，請調整遙控器 SWASH CH6 行程量的正負值，使伺服器同時往上升移，副翼與前後動作相反時，同樣調整 SWASH CH2、CH3 行程量正負值。

FUTABA/HITEC Transmitter/Servo
FUTABA/HITEC遙控器對應伺服器關係

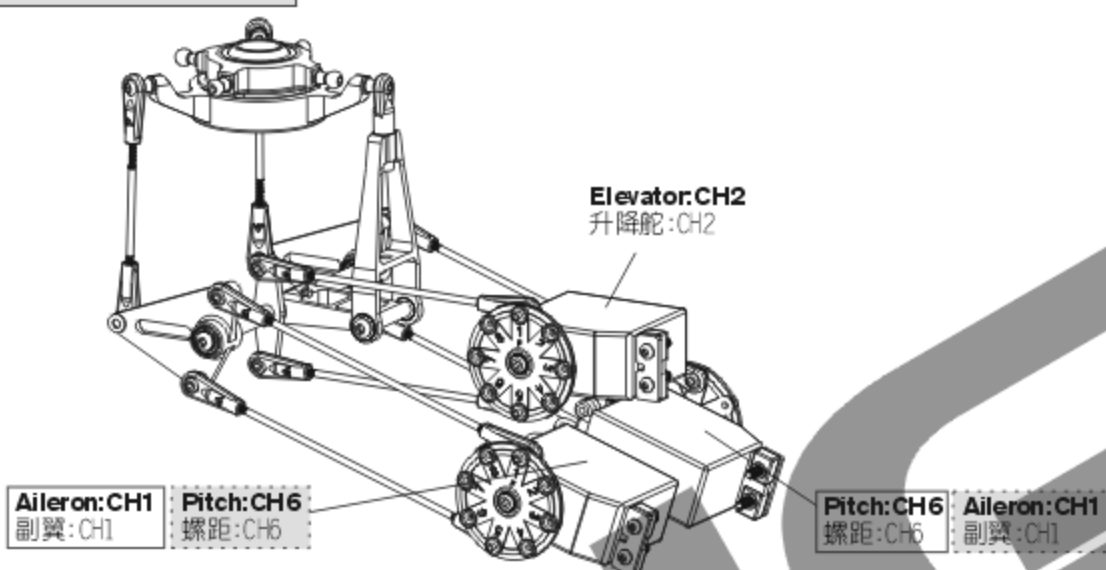

Positions of CH1、CH6 are exchangeable, After assembling as photo (Note: Set the transmitter under CCPM 120 degrees mode), pull throttle stick (pitch) upward. If one swashplate servo (or two servos) moves downward, adjust reverse switch (REV) on the transmitter to make it moves upward. If three servo move downward, adjust the travel value (+) of SWASH CH6 on the transmitter to make them move upward. When the actions of Aileron and Elevator are opposite, adjust travel values of SWASH CH1 and Ch2.

CH1、CH6可互換配置，依圖連結後(注意:遙控器須設定於CCPM 120°十字盤模式)，將油門搖桿(Pitch)往上推，若十字盤伺服器有1個或2個往下移時，請調整搖控器的反轉開關(REV)使伺服器往上，若3個伺服器同時往下移時，請調整遙控器 SWASH CH6 行程量的正負值，使伺服器同時往上升移，副翼與前後動作相反時，同樣調整 SWASH CH1、CH2 行程量正負值。

11.ADJUSTMENTS FOR GYRO AND TAIL NEUTRAL SETTING 陀螺儀與尾翼中立點設定調整

Recommend to choose Head Lock type for Gyro and turn off Revolution mixing(RVMX) mode on the transmitter, then set the gain switch on the transmitter and the gyro to Head lock mode. The gain setting is about 70%, and after transmitter setting, connect to BEC power to work on tail neutral setting. Note: When turn on BEC power, please do not touch tail rudder stick and the helicopter. Then wait for 3 seconds, make tail servo arm and tail servo at a right angle(90 degrees), tail pitch assembly must be correctly fixed about in the middle of the travel of tail rotor shaft for standard neutral setting.

陀螺儀選擇，建議選用鎖定式陀螺儀，其發射器內陀螺儀設定請關閉根軸混控模式，並將發射器上的感度開關與陀螺儀切至鎖定模式，感度設約 70% 左右，發射器設定完成後接上BEC接收電源，即可進行尾中立點設置。注意:當啓動BEC電源時請勿撥動尾舵搖桿或碰觸機體，待3秒陀螺儀鎖定後尾伺服器與尾Pitch控制組約成 90°，尾旋翼控制組須正確置於尾橫軸行程約中間位置，即為標準尾中立點設定。

TAIL NEUTRAL SETTING 尾中立點設定

After setting Head Lock mode, correct setting position of tail servo and tail pitch assembly is as photo. If the tail pitch assembly is not at the neutral position, please adjust the length of rudder control rod to trim.

陀螺儀鎖定後尾伺服器與尾 Pitch控制組正確擺置位置。若尾 Pitch控制組未置中時請調整尾控制連桿的長度來修正。

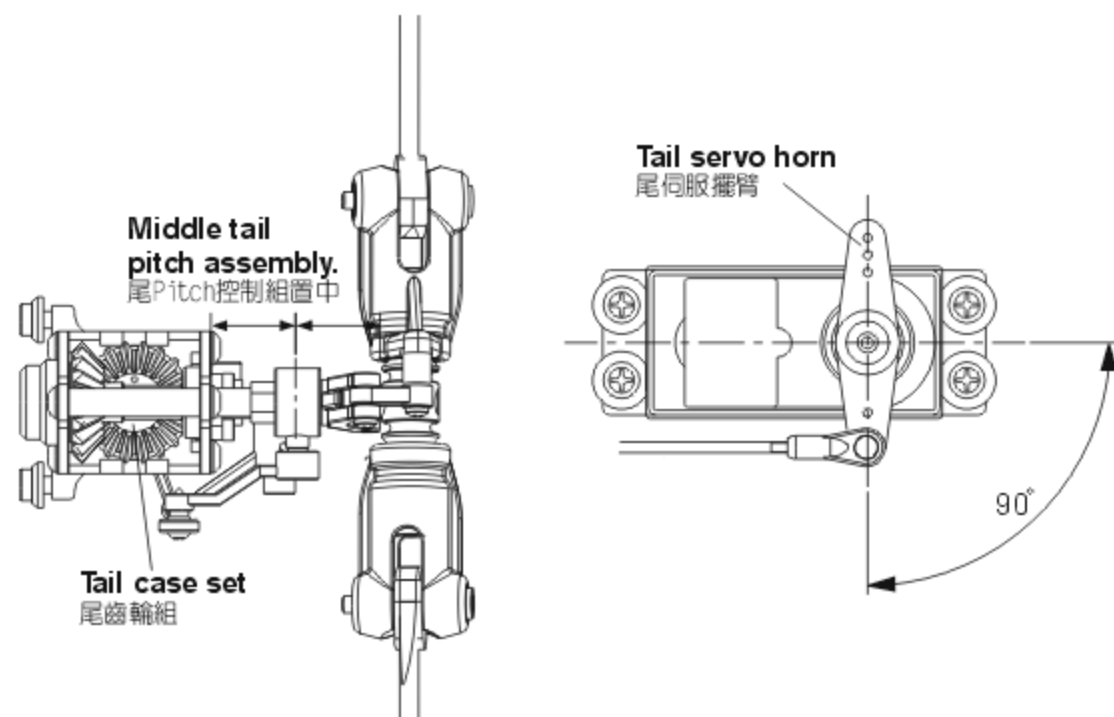

HEAD LOCK DIRECTION SETTING OF GYRO 陀螺儀鎖定方向設定

To check the head lock direction of gyro is to move the tail counterclockwise and the tail servo horn will be trimmed clockwise. If it trims in the reverse direction, please switch the gyro to "REVERSE".

陀螺儀鎖定方向確認，當手搖尾部反時鐘擺動，尾伺服器應順時鐘修正，反向時請切換陀螺儀上"鎖定反向"開關修正。

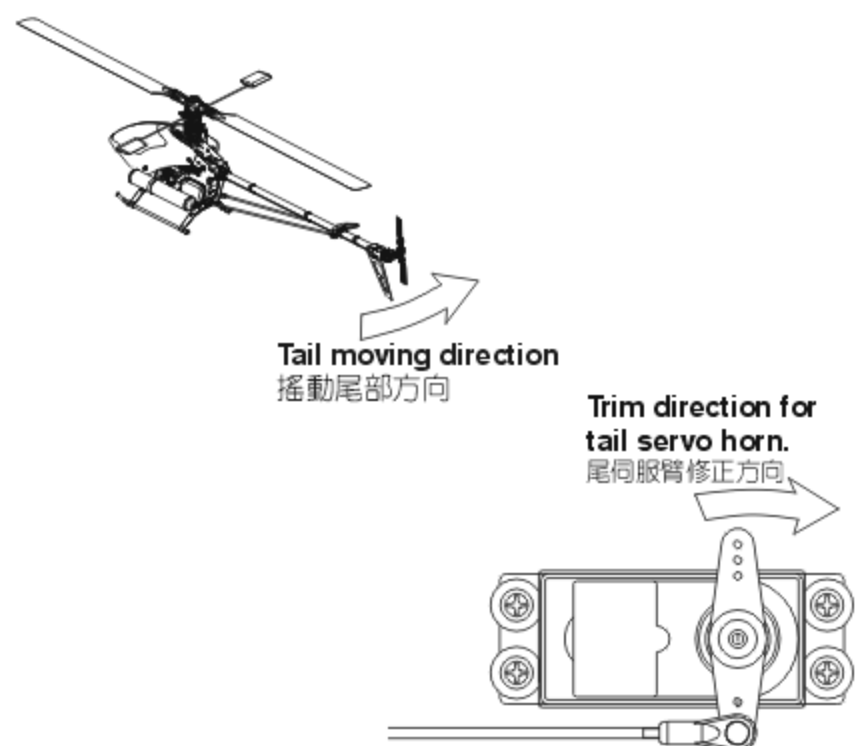

GENERAL FLIGHT 一般飛行模式

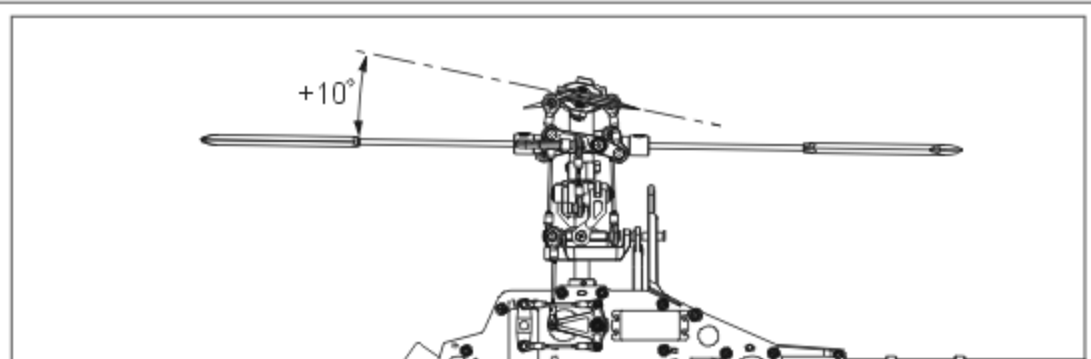

Stick position at high/Throttle 100%/Pitch +10°
搖桿高速/油門100%/Pitch+10°

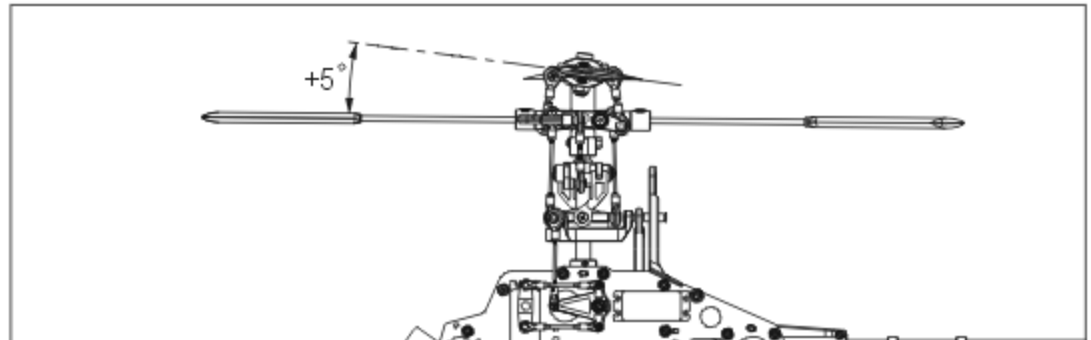

Stick position at Hovering/Throttle 60%/Pitch +5°
搖桿停懸/油門60%/Pitch+5°

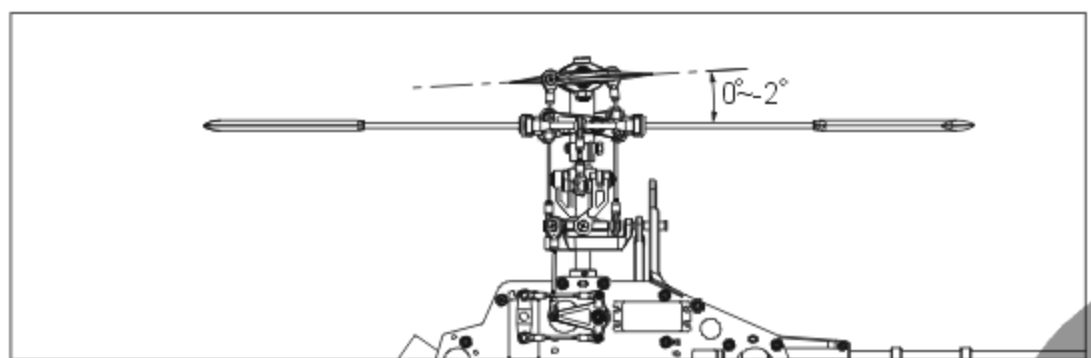

Stick position at low/Throttle 0%/Pitch 0°~-2°
搖桿低速/油門0%/Pitch 0°~-2°

GENERAL FLIGHT 一般飛行模式

	Throttle 油門	Pitch 螺距
5	100% High speed 100% 高速	+10°
4	80%	
3	60% Hovering 60% 停懸	+5°
2	40%	
1	0% Low speed 0% 低速	0°~-2°

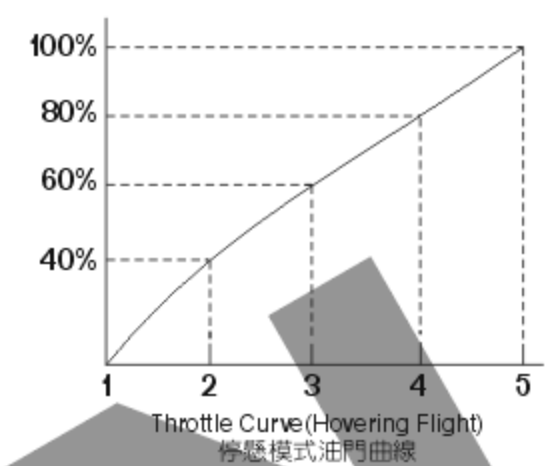

3D FLIGHT 3D特技飛行模式

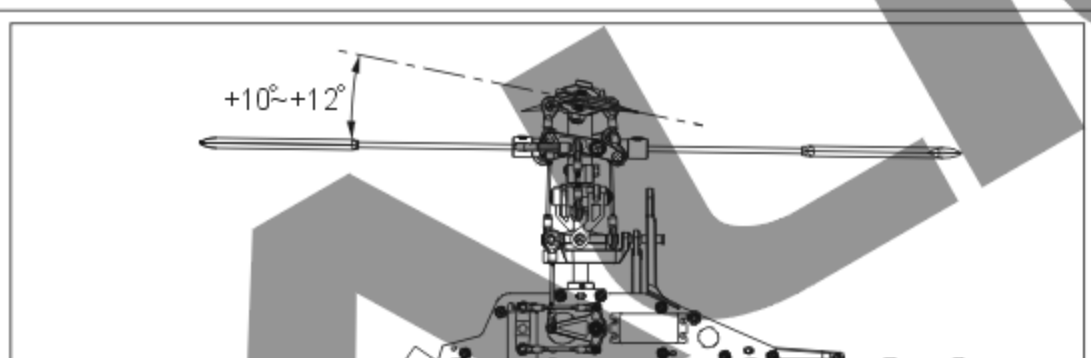

Stick position at high/Throttle 100%/Pitch +10°~+12°
搖桿高速/油門100%/Pitch+10°~+12°

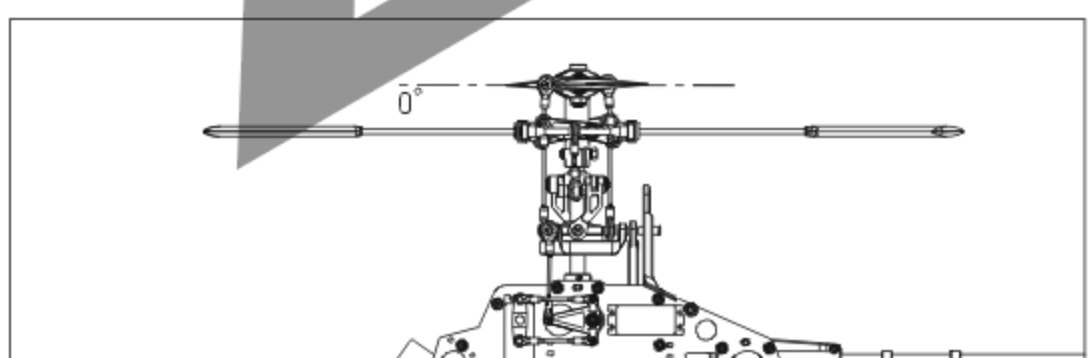

Stick position at middle/Throttle 85%/Pitch 0°
搖桿中速/油門60%-65%/Pitch 0°

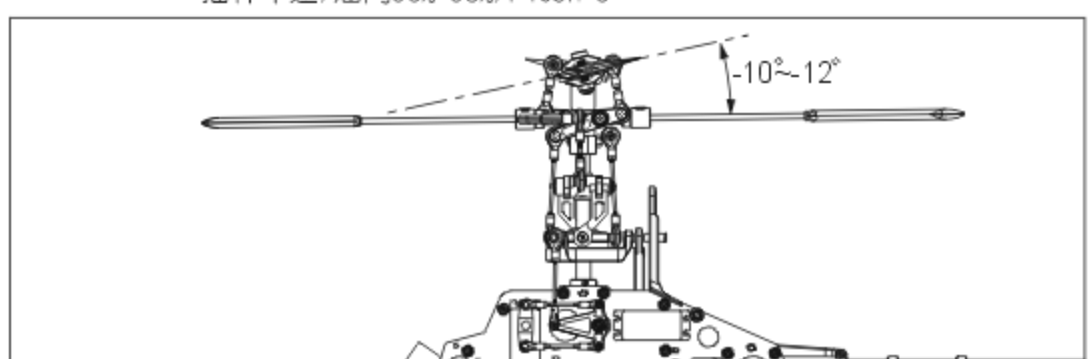

Stick position at low/Throttle 100%/Pitch -10°~-12°
搖桿低速/油門100%/Pitch -10°~-12°

IDLE 1: SPORT FLIGHT

	Throttle 油門	Pitch 螺距
5	100%	+10°~+12°
4	75%	
3	60%	+5°
2	65%	
1	70%	-5°

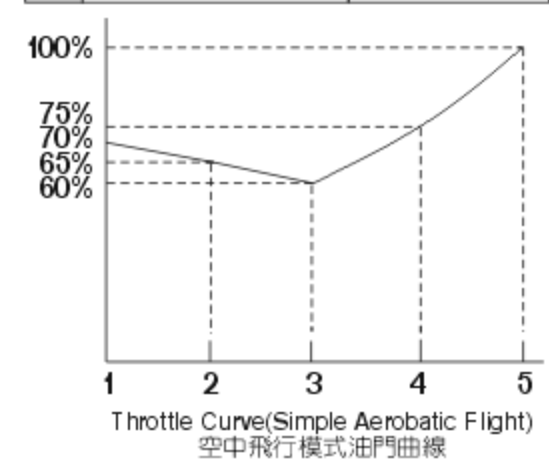

IDLE 2: 3D FLIGHT

	Throttle 油門	Pitch 螺距
5	100% High 100% 高	+10°~+12°
3	60%~65% Middle 60%-65% 中	0°
1	100% Low 100% 低	-10°~-12°

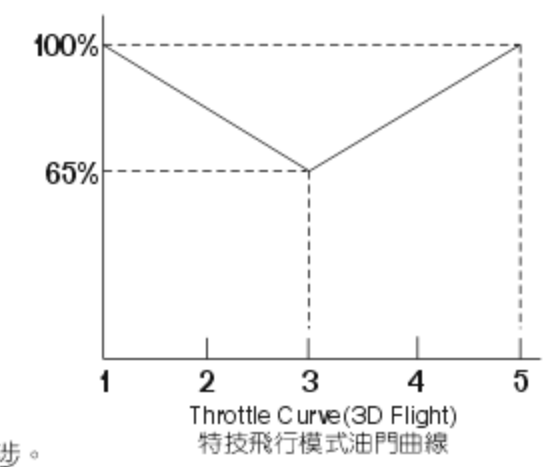

1. Pitch range: Approx ±13 degrees.
2. Hint: Do not exceed ±12 degrees pitch range. Doing so may cause motor overload and binding of certain head components.
3. Hint: Do not tilt swashplate more than 9 degrees. Doing so may cause motor overload and binding of certain head components.



1. 螺距 (Pitch) 總行程約 ±13°。
2. 建議：螺距設定勿超過 ±12°，過大螺距設定，可能導致引擎過載及旋翼頭旋轉干涉。
3. 建議：十字盤傾斜角度設定勿超過 9°，過大螺距設定，可能導致引擎過載及旋翼頭旋轉干涉。

Features 功能說明

1. Compact design, easy use, simple setting with great speed control performance.
2. Speed resolution: 0.1RPM
3. Speed stability accuracy: within 1% (Steady State)
4. Not apply to S9251、S9256 and other 760 μs servos.

1. 造型精巧操作簡易，不需繁雜的設定，同樣有優異的定速表現。
2. 轉速解析度0.1 RPM。
3. 轉速控制精度1%以內 (steady state)。
4. 不適用S9251、S9256等760 μs伺服器。

Specifications 產品規格/配件

1. Operating voltage: DC 4.5V-6V
2. Consumption current: <20mA@4.8V
3. Direct detection of engine rotation speed
4. Speed control range: 10500~21000RPM
5. Servo RWM output pulse width: 1~2ms, not apply to S9251, S9256, other 760 μs servos.
6. Operating temperature range: -20°C~85°C
7. Operating moisture range: 0%~95%
8. Case size (body): 28.5x26.2x9mm
9. Signal wire length: 160mm
10. Sensor wire length: 250mm
11. Weight: 10g (including wires)
12. Accessories: Magnet x 2pcs
Screw (T2.6x6) x 2pcs
Governor mount x 1pc

1. 工作電壓: DC 4.5V-6V。
2. 消耗電流: <20mA@4.8V。
3. 直接偵測引擎轉速。
4. 定速範圍: 10500~21000RPM。
5. 伺服器PWM輸出波寬1~2ms，不適用 S9251、S9256等760 μs 伺服器。
6. 工作溫度範圍-20°C~85°C。
7. 工作濕度範圍: 0%~95%。
8. 本體外殼尺寸: 28.5x26.2x9mm。
9. 訊號線長: 160mm。
10. 轉速感應線長: 250mm。
11. 重量: 10g (含線組)。
12. 配件: 轉速感應磁鐵x2pcs。
半圓頭內六角螺絲 (T2.6x6) x2pcs。
定速器固定座x1pc。

Instruction 安裝使用說明

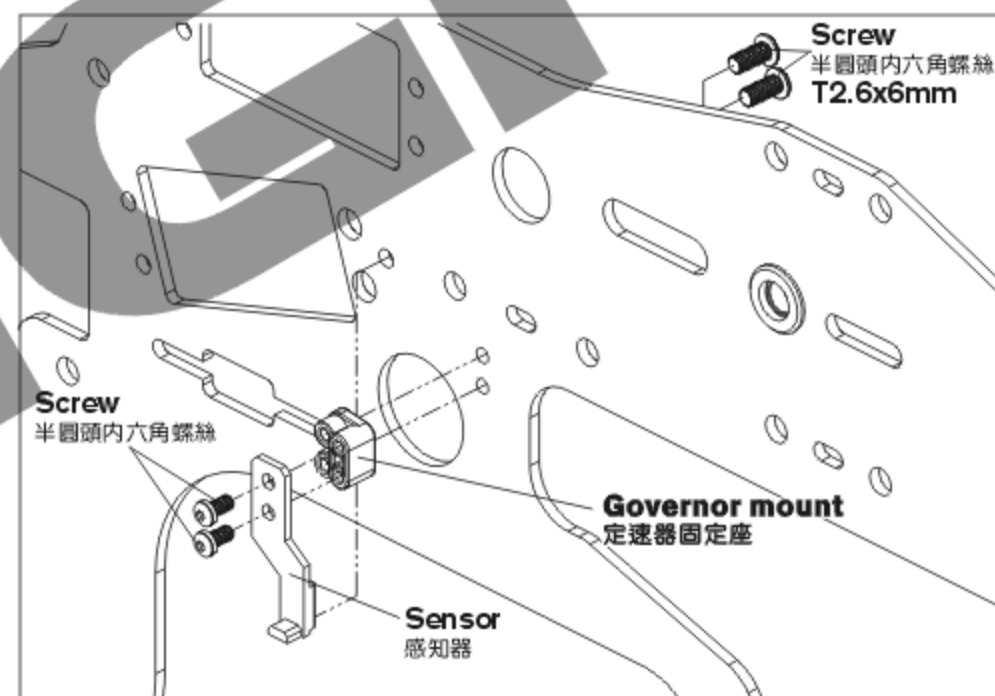
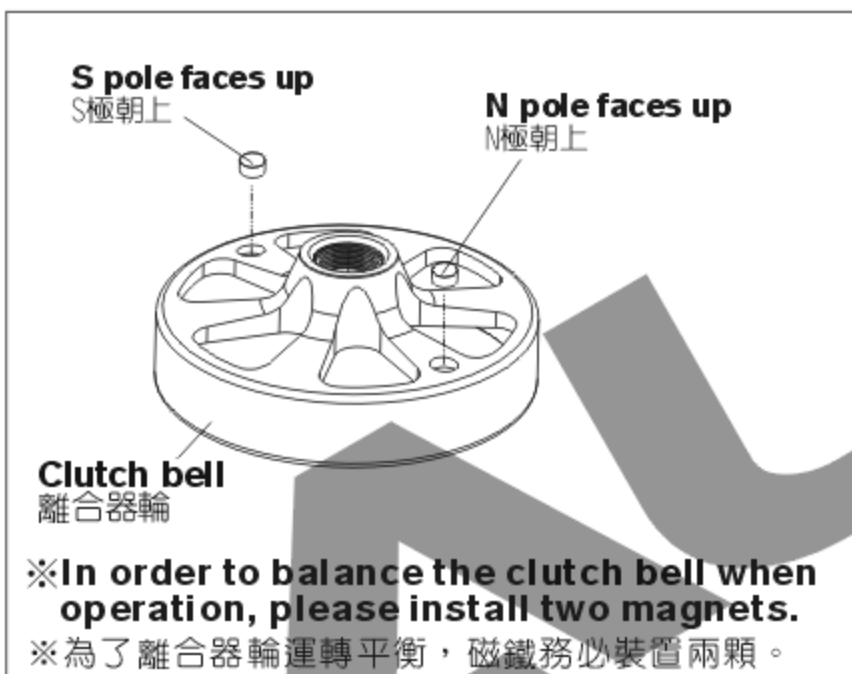

1. See Fig. 1, first install two magnets on the mounting hole of the Clutch bell with CA glue or R48 glue, the north pole of one magnet (mark N) faces up and the north pole of the other magnet faces down.
NOTE: Magnets must be firmly secured. If the magnet falls from the engine fan during the flight, the governor will automatically cut out the speed control function.
2. See Fig. 2, install the sensor on the main frame, and check if any interference caused by the clutch bell.
3. Before connecting to the governor, first please check the rotation direction (clockwise/anti-clockwise) of throttle servo and travel range are correct.
4. Choose an un-used switch for governor ON/OFF switch. Connect the yellow sign wire of the governor to the receiver's channel. Then connect the governor to the power and make sure that turning on the switch is for Governor ON and off is for Governor OFF. (Green LED light is governor ON mode, and Red LED light is governor OFF mode)
5. When connecting the governor to the power, LED light is on. When the magnet is lapped over the sensor, the LED light will be off. (If the LED isn't off, please check the polarity of the magnet and check if the wire is well connected and check for the distance between the sensor and the magnet.)
6. Adjustment of throttle travel: First place the throttle stick at the lowest position, and then turn on the transmitter. After that turn on the receiver. When the LED light is on, press "Throttle Travel Setting" button on the governor for 3 seconds. While the LED light flash, please place the throttle stick at the highest position. Then the LED light will be off and later be on again, it means the setting is completed.
NOTE: Do not run the engine before completing the throttle limit setting, to avoid the throttle travel error or servo reversion.
7. When normal, the throttle curve is straight (0%/50%/100%). When Idle, the throttle curve cannot be lower than 50%. When the governor fails, it will go back to the governor OFF mode. Therefore, even though you have installed the governor, the throttle curve of transmitter must be set as regular setting.
8. Two conditions- Governor will be enabled:
(1) Turn on the governor switch, and LED light is green. (2) Throttle position > 30% and more.
9. When the governor turns on, the rotation speed of the engine is controlled by the ATV (%) which is the channel chosen on the 4th step. The following chart is ATV setting and engine rotation speed for Futaba and JR transmitters. The rotation speed of main blade is converted according to the engine ratio of original helicopter.

1. 如圖一先將轉速感應磁鐵一顆 N 極朝上 (作記號的面為 N 極)，一顆 N 極朝下，以 CA 或 R48 黏著在離合器輪預留的磁鐵座上。
※注意: 磁鐵須固定牢靠，若飛行中磁鐵不慎脫落，定速器將自動取消定速功能。
2. 如圖二標示之位置將轉速感知器安裝於側板上，並檢查是否與離合器輪產生干涉的情形。
3. 連接定速器前，先確定油門伺服器正逆轉及機械行程是否正確。
4. 選一個遙控器上未使用的通道開關，作為定速與非定速的切換開關，並將定速器的黃色訊號線接到接收器上對應此開關的通道，接著將定速器接上電源後撥動此開關，以確定開啓是定速模式，及關閉是非定速模式 (於定速模式時定速器上的 LED 為綠燈，非定速模式 LED 為紅燈)。
5. 定速器接上電源後，LED 恆亮，當磁鐵與感知器重合時，LED 會熄滅。
(如 LED 未熄滅，需檢查磁鐵極性是否正確？線路連接是否正確？感知器及磁鐵距離是否正確？)
6. 油門行程的校正：先將油門置於最低點的位置，將發射機電源打開，開啓接收機電源，當 LED 亮起後按定速器上的設定鍵三秒後，此時 LED 會閃爍，接著將油門撥桿推到最高點位置，稍等 LED 會先熄滅後重新亮起，即完成設定作業。
※注意: 未執行定速器油門行程設定前切勿發動引擎，以免油門行程錯誤或發生伺服器反向之情形。
7. 油門曲線在 normal 時為直線 (0%/50%/100%)，idle 油門曲線最低點不可低於 50%，即使有安裝定速器，遙控器的油門曲線仍要依照正常的模式來設定，因為當定速器失效時會返回非定速模式。
8. 定速器的啓動條件有二項: (1) 定速器開關開啓，LED 亮綠燈。(2) 油門位置 >30% 以上。
9. 當啓動定速功能時，引擎的轉速即交由第 4 步驟所選定通道的行程量 (ATV) 百分比 (%) 來進行控制，下表為 Futaba 與 JR 遙控器 ATV 設定值與引擎轉速的對照表，主旋翼的轉速請依原廠直昇機的引擎齒比換算。

ATV	FUTABA PCM 1024Z		FUTABA T14MZ/T12FG/T12Z		JR PCM10S/9X/9XII	
	Engine speed 引擎轉速	T-REX 700N Main blade speed 8.2:1 主旋翼轉速 8.2:1	Engine speed 引擎轉速	T-REX 700N Main blade speed 8.2:1 主旋翼轉速 8.2:1	Engine speed 引擎轉速	T-REX 700N Main blade speed 8.2:1 主旋翼轉速 8.2:1
10%	10500	1280	10500	1280	10500	1280
20%	10500	1280	10500	1280	10500	1280
30%	12000	1463	10800	1317	10500	1280
40%	13700	1670	12000	1463	11200	1366
50%	15400	1878	13300	1622	12400	1512
60%	17070	2082	14550	1774	13600	1658
70%	18760	2288	15800	1927	14850	1811
80%	20410	2489	17100	2085	16000	1951
90%	21000	2560	18340	2237	17200	2098
100%	21000	2560	19700	2402	18450	2250
110%	21000	2560	20860	2544	19640	2395
120%	21000	2560	21000	2560	20760	2532
130%	21000	2560	21000	2560	21000	2560
140%	21000	2560	21000	2560	21000	2560
150%	21000	2560	21000	2560	21000	2560

NOTE: If the LED light is off, please check if the magnet is lapped over the sensor. Please turn the magnet position of clutch bell to let the LED light on.

註: 如開機時定速器燈沒亮，有可能是磁鐵跟感知器重合，請轉動離合器輪磁鐵位置，讓指示燈亮起。

Features 功能說明

1. Due to the unique 2 in 1 design, the regulator's functions provide power to the receiver, servos, and the internal glow plug ignition system that does not require you to remove the clip lead.
2. The linear regulator design results in no interference to the receiver. The required input power may only consist of a 2 cell Li-ion or a Li-Poly battery.
3. When the integrated power switch is moved to the on position, the voltage indicating LED's and ignition indicating LED's will illuminate displaying the status of the battery voltage, and of the plug ignition function.

1. 獨特的二合一設計，除了具備(BEC)降/穩壓系統，以提供接收器與伺服器電源的功能外，還內建一組火星塞的點火裝置，省卻傳統電夾插拔的麻煩。
2. 本產品採用線性設計，輸入電源為2CELL的Li-ion或Li-Poly電池，其優點為不會像交換式設計的BEC會產生干擾接收器的情形，免於摔機的恐懼。
3. 具備電源開關、電壓指示燈及點火指示燈功能，可由燈號判定電池殘量與火星塞的點火狀態。

Specifications 產品規格/配件

1. Input Voltage: DC 7.4V 2 cell Lithium or Li-Poly battery
2. Output Voltage: DC 5.8V(BEC)/1.5V(Glow Plug)
3. Max. Continuous Current: 6A
4. Weight: 53.5g (including wires)
5. Regulator size: 80x30x13.3mm
Control board size: 35x24x10mm

1. 輸入電壓: DC 7.4V 2CELL 鋰電
2. 輸出電壓: DC 5.8V (BEC) / 1.5V (Glow Plug)
3. 最大連續輸出電流: 6安培
4. 重量: 53.5g (含線組)
5. 尺寸: 降壓器 80x30x13.3mm
控制板 35x24x10mm

Instruction 安裝使用說明**Receiver and Servo Voltage Regulating Functions:**

1. The Auto-detecting voltage LED's will display a series of lights when turned on. If the entire five-light array is illuminated then the battery is fully charged. When the voltage drops below 7.6V the three green lights will turn off. USE CAUTION: Once the green lights are no longer illuminated the battery can only be safely used for a single flight. When only the single red LED is lit, DO NOT ATTEMPT TO OPERATE THE MODEL The battery voltage has been drained too low, and must be recharged before its next use.
2. It is important to note that not all servos are designed to operate on 6 volts, such as Futaba servo models 9241, 9251, 9253, 9254, 9255, 9256 and other digital servo are not capable of handling 6V. Please check with the manufacturing specifications of the servo before attempting to operate. A separate 5.1V inline voltage Step-Down may be purchased and is recommended for use between the gyro and the tail servo, and any servos that are not designed to handle 6V. Please note that some servos are designed for running on 6V and may not require a voltage step-down.

接收器與伺服器電源部份:

1. 本產品具電壓指示功能，當接入充飽的電池時五顆指示燈全亮，表示電池在Full電量充足狀態下：使用中當電壓降低至7.6V時(3顆綠燈熄滅)，尚可完成單趟飛行即須對電池充電或更換新電池；而如果僅亮紅燈時表示Empty電量不足，不應該再使用囉！
2. 部份的伺服器如:Futaba 9241, 9251, 9253, 9254, 9255, 9256等，此類型的伺服器不適合於較高的電壓下操作，所以使用此類型的伺服器時請另外加裝5.1V降壓調整器於陀螺儀與尾舵伺服器間，避免伺服器損壞；規格標標準許6V輸入的伺服器則不須使用調整器。

Glow Plug Ignition System Functions:

1. Start by connecting the wires using the included diagram as a reference. Once completed connect the battery and move the power switch to the on position. Depress the "START" button on the control board. The green and the orange lights will illuminate. When this happens the glow plug is being ignited for a period of 15 seconds. After 15 seconds, the control board will stop igniting the glow plug. If the engine has not yet been started, the process can be repeated by simply repressing the "START" button. The Ignition system is designed to automatically shut off once the engine starts running. To ensure that the system is operating properly, check to make sure that the orange and green lights have shut off once the engine starts running. In the event that the lights are still illuminated once the engine is running, it may be necessary to remove the lead clip from the engine.
2. If the orange light is not illuminated after pressing "START" then this means that the glow plug is not being ignited. Please check to see if the element of the glow plug has burned out, or if the lead clip is not properly connected to the glow plug.
3. If the Glow plug is short-circuited or the lead clip has contacted the outer case of the engine, the red (SHORT) light will be illuminated approx. 1 second after pressing the "START" button. If the "SHORT" light illuminates the system will automatically shut off the power to the output leads.

火星塞點火器部分:

1. 依接線示意圖完成接線後，開啓電源開關，接著按下控制電路板上的"START"鍵，此時點火指示燈的綠燈與橘燈同時亮起，表示火星塞已正常點火中，每次點火時間約為15秒，15秒後自動關閉，如需再次點火時，則再按一次"START"鍵；由於點火裝置會自動關閉，所以引擎啟動後，確認橘色、綠色指示燈於15秒後熄滅，即不須將鱷魚夾移除。
2. 若按下"START"鍵時，橘燈不亮，表示火星塞未正常點火，請檢查火星塞加熱線圈是否開路損壞，或是鱷魚夾未確實夾在火星塞電極端上。
3. 如果火星塞發生短路或是鱷魚夾(電源正端)與引擎外殼接觸時，當按下"START"鍵，紅色(SHORT)指示燈會亮起，約1秒後熄滅並隨即關閉電源輸出，請檢查火星塞是否損壞或檢查鱷魚夾是否接觸到引擎外殼。

NOTE: Please use double-sided foam tape or hook & loop tap to fix the regulator on the helicopter. Please do not tighten the wires of regulator hard to avoid the wires loose or broken caused by the vibration during the operation of the helicopter.

注意: 請使用泡綿雙面膠或魔術沾將降壓器與直昇機固定，降壓器的各線組請勿繃緊固定，以免直昇機運轉時因震動造成接頭鬆脫或斷線。

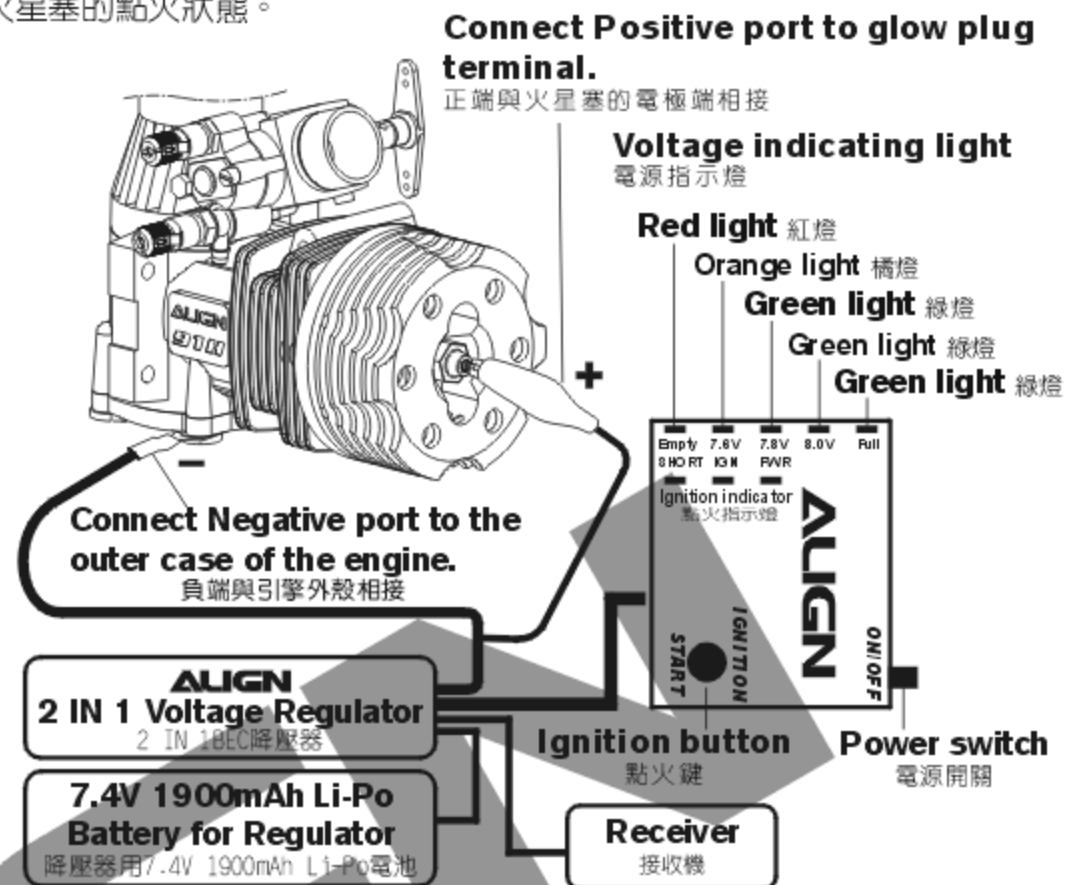

Please practice simulation flight before real flying 飛行前請事先熟練電腦模擬飛行

A safe and effective practice method is to use the transmitter flying on the computer through simulator software sold on the market. Do a simulation flight until you familiarize your fingers with the movements of the rudders, and keep practicing until the fingers move naturally.

1. Place the helicopter in a clear open field (Make sure the power OFF) and the tail of helicopter point to yourself.
2. Practice to operate the throttle stick(as below illustration) and repeat practicing "Throttle high/low", "Aileron left/right", "Rudder left/right", and "Elevator up/down".
3. The simulation flight practice is very important, please keep practicing until the fingers move naturally when you hear operation orders being call out.

在還沒瞭解直昇機各動作的操控方式前，嚴禁實機飛行，請先進行電腦模擬飛行的練習，一種最有效、最安全的練習方式，就是透過市面販售的模擬軟體，以遙控器在電腦上模擬飛行，熟悉各種方向的操控，並不斷的重複，直到手指可熟練的控制各個動作及方向。

1. 將直昇機放在空曠的地方(確認引擎為熄火狀態)，並將直昇機的機尾對準自己。
2. 練習操作遙控器的各搖桿(各動作的操作方式如下圖)，並反覆練習油門高/低、副翼左/右、升降舵前/後及方向舵左/右操作方式。
3. 模擬飛行的練習相當重要，請重複練習直到不需思索，手指能自然隨著喊出的指令移動控制。

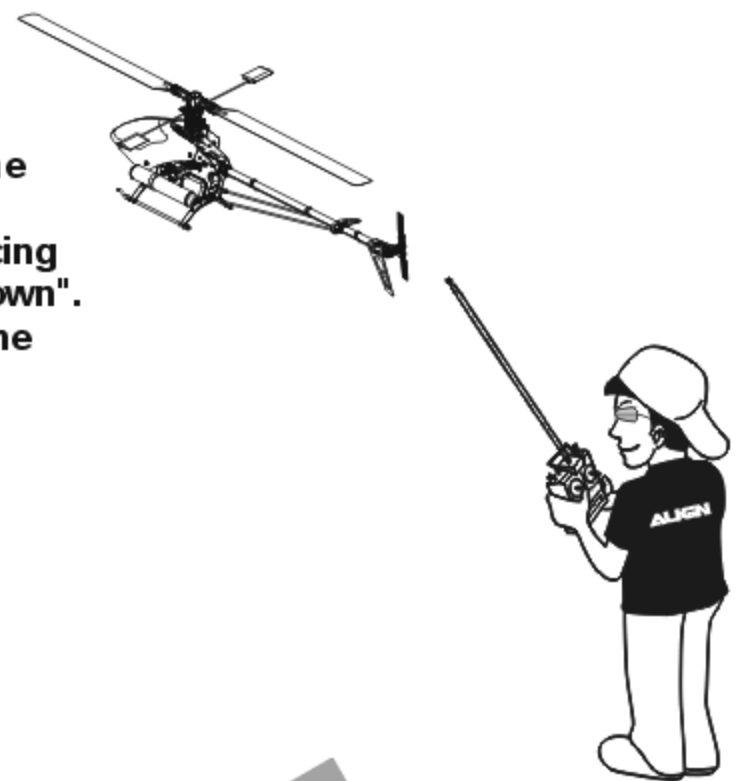

Mode 1	Mode 2	Illustration 圖示
 Aileron 副翼	 Aileron 副翼	 Move left 左移 Move right 右移 Rotate left 左翻 Rotate right 右翻
 Elevator 升降/前後	 Elevator 升降/前後	 Fly forward 前進 Fly backward 後退 Forward rotate 前翻 backward rotate 後翻
 Throttle 油門	 Throttle 油門	 Ascent 上升 Descent 下降
 Rudder 方向	 Rudder 方向	 Turn right 右旋 Turn left 左旋

Flight adjustment and notice 飛行調整與注意



- Check if the screws are firmly tightened.
- Check if the transmitter and receivers are fully charged.
- 再次確認→螺絲是否鎖固?
- 發射器和接收器電池是否足夠。

- ★ When arriving at the flying field.
- ★ 當抵達飛行場



If there are other radio control aircraft at the field, make sure to check their frequencies and tell them what frequency you are using. Frequency interference can cause your model, or other models to crash and increase the risk of danger.
假使飛行場有其他遙控飛機，請確認他們的頻率，並告知他們你正在使用的頻率，相同的頻率會造成干擾導致失控和大大地增加風險。

Engine start preparation 引擎啟動事前準備

Separate the fuel tube and the joint and start to refuel. Please be careful to avoid the dust entering the tube. When the fuel tank is full, please stop refueling and reconnect the tube and the joint.
將油管與其接頭分離，並開始補給燃料。請小心避免灰塵砂粒進入管子內。當油箱已滿，請停止補給燃料並再將管子和接頭接合。

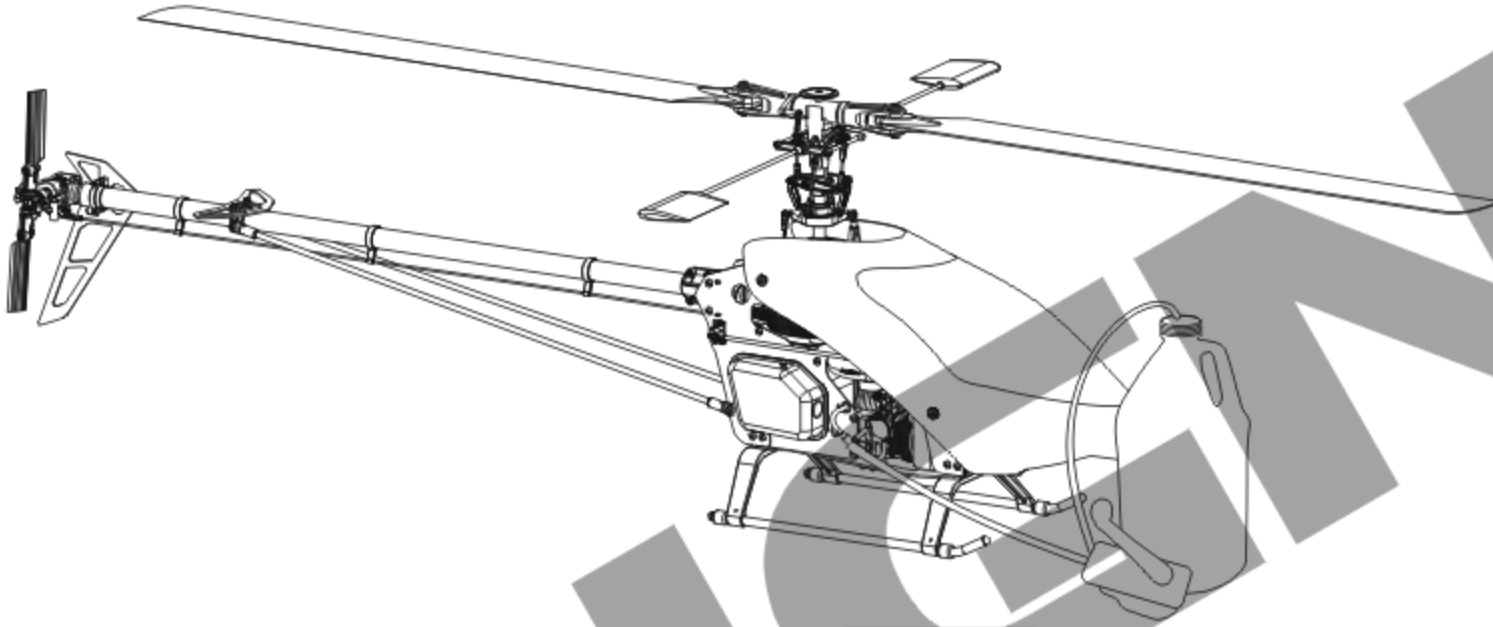

First check to make sure no one else is operating on the same frequency. Then place the throttle stick at lowest position and turn on the transmitter.
首先確認附近沒有其他相同頻率的使用，然後打開發射器將油門搖桿推到低點。



Check if the throttle stick is set at the lowest position and check if engine throttle is at low speed.
確認油門搖桿是在最低的位置，並確認引擎油門置於低速。

Mode 1

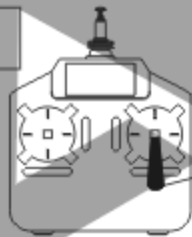

Mode 2

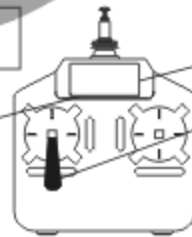

Glow plug ignition method 火星塞點火方式

Method 1
方式一

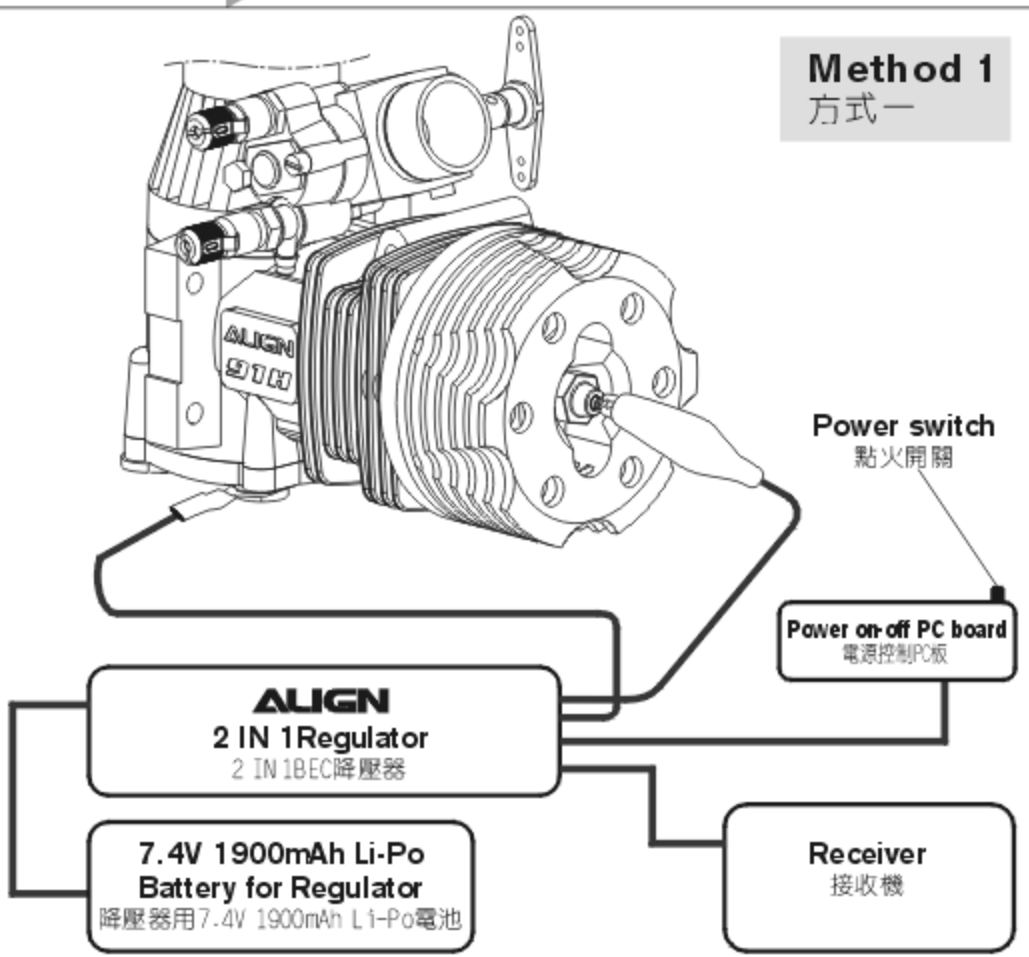

Method 2
方式二

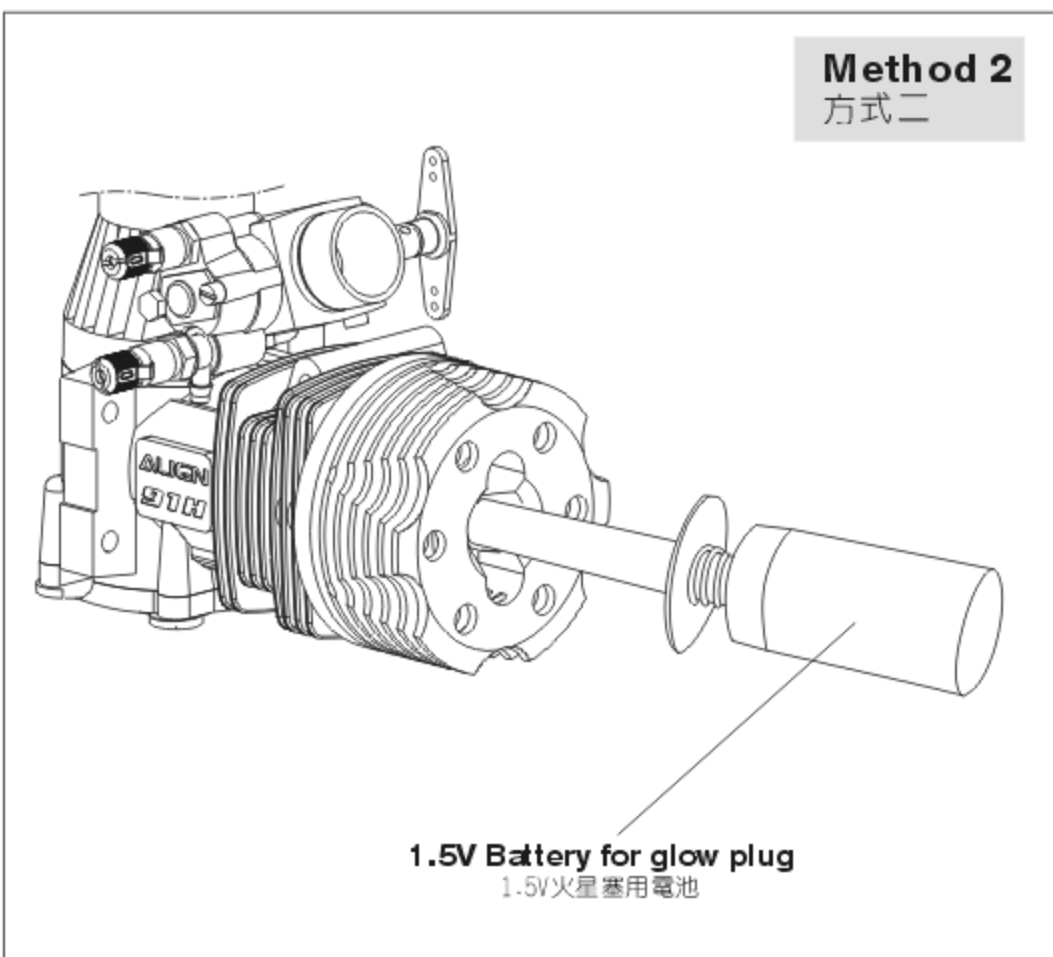

Engine start and stop 引擎啟動和熄火

1. Connect the battery to the starter and check the rotation direction. Insert the starter shaft into the starter completely.
2. Tightly hold the main rotor head, and insert the starter shaft into the starter coupling. Then turn the starter to start the engine.
3. When the engine starts, stop the starter and remove it from the starter coupling. Please keep holding the main rotor head tightly.
4. Hold the main rotor head tightly, and turn off the power of glow plug or remove the power.
5. Still hold the main rotor head tightly, turn throttle trim at the lowest position, and keeping engine in lowest regular running.
6. If you want to stop the engine, please set the throttle trim (beside the throttle stick) at the lowest position. If the engine cannot stop, please put the Fuel Clip into lock position to stopping refueling.

1. 將啟動電池連接到啟動器並確認其轉動方向。將啟動軸完全插入啟動器。
2. 緊緊抓住主旋翼頭部，將啟動軸插入引擎啟動頭並以啟動器啟動引擎。
3. 當引擎啟動後，停止啟動器並將啟動頭上的啟動器移開。請保持繼續緊緊抓住主旋翼頭部。
4. 仍然緊緊抓住主旋翼頭部，將火星塞點火電池關閉或移開。
5. 仍然緊緊抓住主旋翼頭部，請保持油門於最低點時，引擎能保持於低怠速下正常運轉。
6. 欲將引擎熄火時，只需將油門搖桿旁的油門微調調至最低即可；如果引擎仍無法停止，請將油管夾片推至鎖定位置，關閉油料供給。

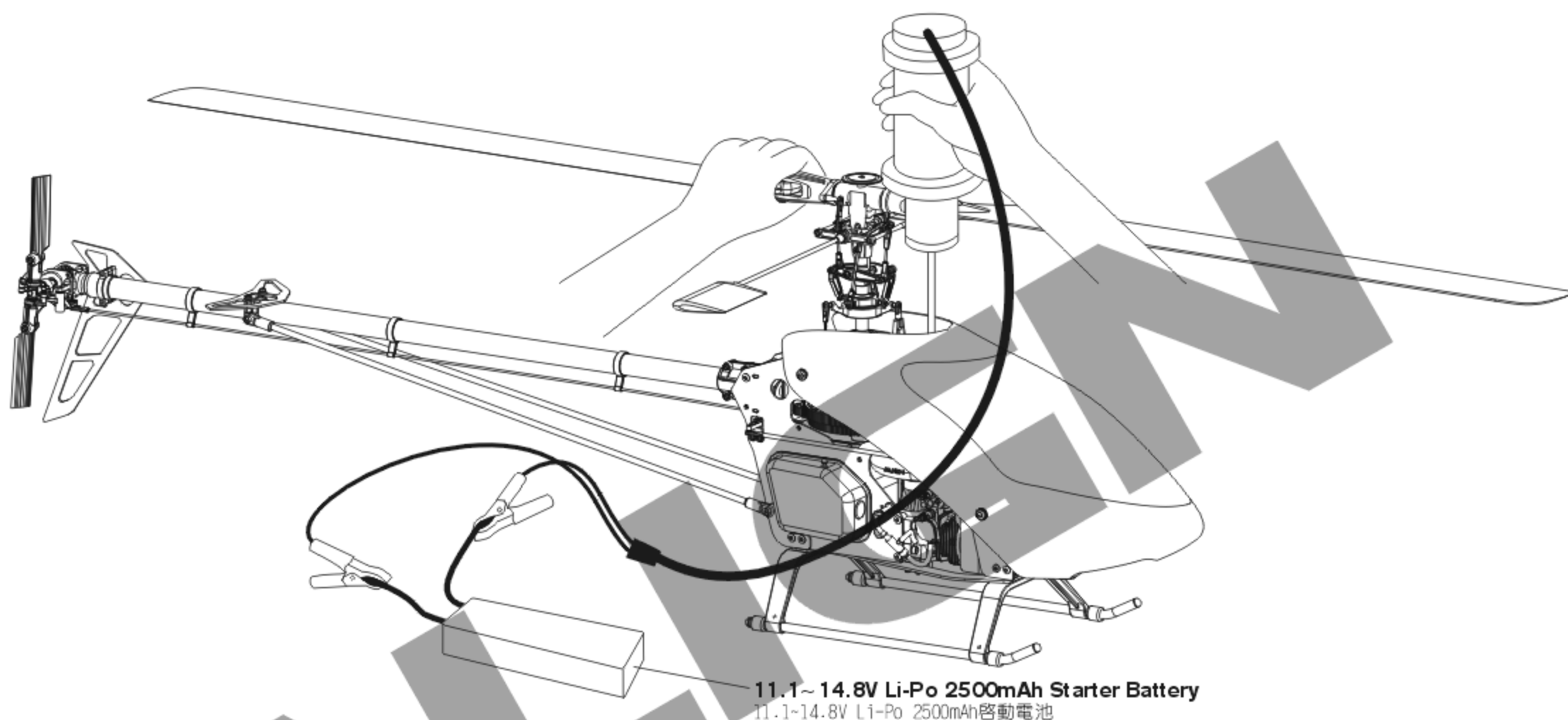

Main rotor adjustments 主旋翼雙槳平衡調整



Tracking adjustment is very dangerous, so please keep away from the helicopter at a distance of at least 10m.
調整軌跡非常危險，請於距離飛機最少10公尺的距離。

1. Before adjusting, apply a red piece of tape on one blade, or paint a red stripe with a marker or paint to identify on blade.
2. Raise the throttle stick slowly and stop just before the helicopter lifts-off ground. Look at the spinning blades from the side of the helicopter.
3. Look at the path of the rotor carefully. If the two blades rotate in the same path, it does not need to adjustment. If one blade is higher or lower than the other blade, adjust the tracking immediately.
4. Linkage rod (A): Regular pitch trim (For large variations). Linkage rod (C): Slight pitch trim (For slight variations).

1. 調整前先在其中一支主旋翼的翼端，貼上有顏色的貼紙或畫上顏色記號，方便雙槳調整辨識。
2. 慢慢的推起油門搖桿到高点並且停止，在飛機離開地面前，從飛機側邊觀察主旋翼轉動。
3. 仔細觀察旋翼軌跡(假如兩支旋翼移動都是相同軌跡，則不需要調整；可是如果一支旋翼較高或較低產生“雙槳”的情形時，則必須立刻調整軌跡)。
4. 連桿(A)為一般螺距調整(雙槳翼大時使用)。連桿(C)為螺距微調調整(雙槳微幅差異時使用)。

A. When rotating, the blade with higher path means the pitch too big. Please lengthen pitch linkage rod (A) for regular trim or shorten linkage rod (C) for slight pitch trim.

B. When rotating, the blade with lower path means the pitch too small. Please shorten pitch linkage rod (A) for regular trim or lengthen linkage rod (C) for slight pitch trim.

- A. 旋翼轉動時較高軌跡的主旋翼表示螺距(PITCH)過大，請調長連桿(A)修正，或需要更小的螺距微調時，請調短連桿(C)修正。
- B. 旋翼轉動時較低軌跡的主旋翼表示螺距(PITCH)過小，請調短連桿(A)修正，或需要更小的螺距微調時，請調長連桿(C)修正。



Incorrect tracking may cause vibrations. Please repeat adjusting the tracking to make sure the rotor is correctly aligned. After tracking adjustment, please check the pitch angle is approx. 5° when hovering.

不正確的旋翼軌跡會導致震動，請不斷重複調整軌跡，使旋翼軌跡精準正確。
在調整軌跡後，確認一下Pitch角度在停旋時應為大約5°。



FLIGHT ADJUSTMENT AND NOTICE 飛行調整與注意



- ◎ Make sure that no one or obstructions in the vicinity.
- ◎ For flying safety, please carefully check if every movement and directions are correct when hovering.
- ◎ 確認鄰近地區沒有人和障礙物。
- ◎ 為了飛行安全，你必須先確認停懸時各項操控動作是否正常。

- ◎ During the operation of the helicopter, please stand approximately 10m diagonally behind the helicopter.
- ◎ 飛行時，請站在直昇機後方10公尺。



Do not attempt until you have some experiences with the operation of helicopter.
嚴禁無熟練操控飛行經驗者操控飛行。



STEP 1 THROTTLE CONTROL PRACTICE 油門控制練習

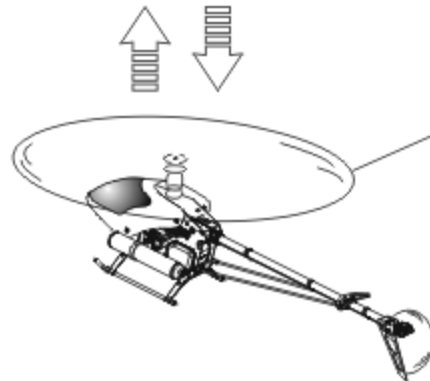
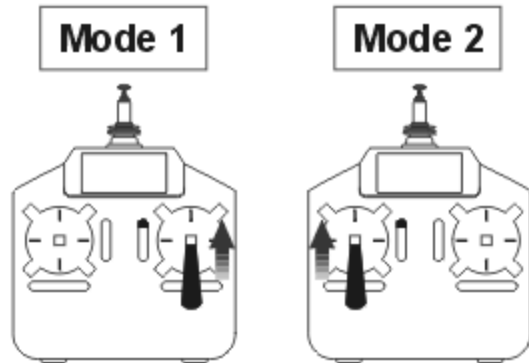

- ◎ When the helicopter begins to lift-off the ground, slowly reduce the throttle to bring the helicopter back down. Keep practicing this action until you control the throttle smoothly.
- ◎ 當直昇機開始離地時，慢慢降低油門將飛機降下。持續練習飛機從地面上升和下降直到你覺得油門控制很順。

STEP 2 AILERON AND ELEVATOR CONTROL PRACTICE 副翼和升降控制練習

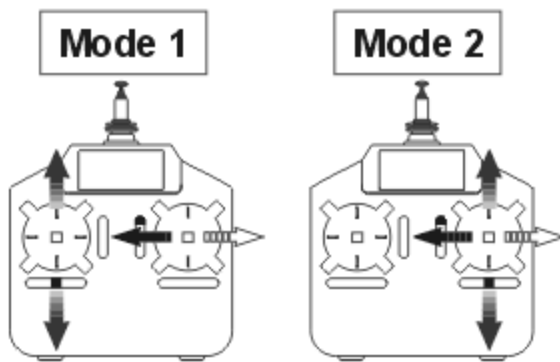

1. Raise the throttle stick slowly.
2. Move the helicopter in any direction back, forward, left and right, slowly move the aileron and elevator sticks in the opposite direction to fly back to its original position.

1. 慢慢升起油門搖桿。
2. 使直昇機依指示：移動向後/向前/向左/向右，慢慢的反向移動副翼和升降搖桿並將直昇機開回到原來位置。



- ◎ If the nose of the helicopter moves, please lower the throttle stick and land the helicopter. Then move your position diagonally behind the helicopter 10m and continue practicing.
- ◎ If the helicopter flies too far away from you, please land the helicopter and move your position behind 10m and continue practicing.
- ◎ 當直昇機機頭偏移時，請降低油門並且降落，然後移動自己的位置到直昇機的正後方10公尺再繼續練習。
- ◎ 假如直昇機飛離你太遠，請先降落直昇機，並到直昇機後10公尺再繼續練習。

STEP 3 RUDDER CONTROL PRACTICING 方向舵操作練習

1. Slowly raise the throttle stick.
2. Move the nose of the helicopter to right or left, and then slowly move the rudder stick in the opposite direction to fly back to its original position.

1. 慢慢升起油門搖桿。
2. 將直昇機機頭移動左或右，然後慢慢反向移動方向舵搖桿並將直昇機飛回原本位置。

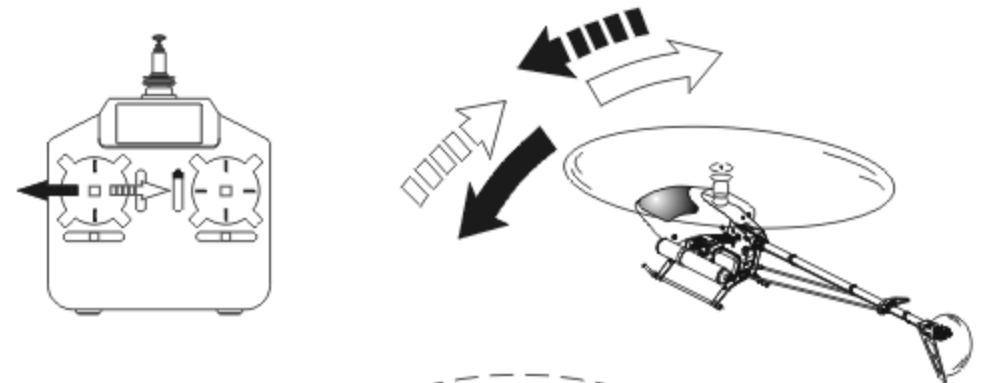

STEP 4

After you are familiar with all actions from Step1 to 3, draw a circle on the ground and practice within the circle to increase your accuracy.

當你覺得 step1-3 動作熟悉了，在地上畫圈圈並在這個圈圈的範圍內練習飛行，以增加你操控的準確度。

- ◎ You can draw a smaller circle when you get more familiar with the actions.
- ◎ 當你更加習慣操作動作，你可以畫更小的圈圈。

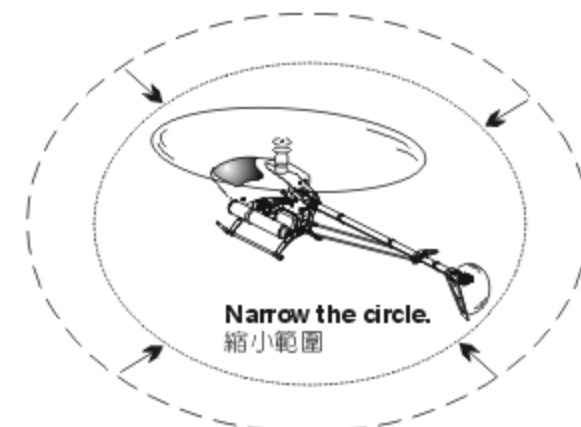

STEP 5 DIRECTION CHANGE AND HOVERING PRACTICE 改變直昇機方向和練習停旋

After you are familiar with Step1 to 4, stand at side of the helicopter and continue practicing Step1 to 4.

Then repeat the Step1 to 4 by standing right in front of the helicopter.

當你覺得step1-4動作熟悉了，站在面對直昇機側邊並繼續練習step1-4。之後，站在直昇機機頭右邊重複步驟練習。

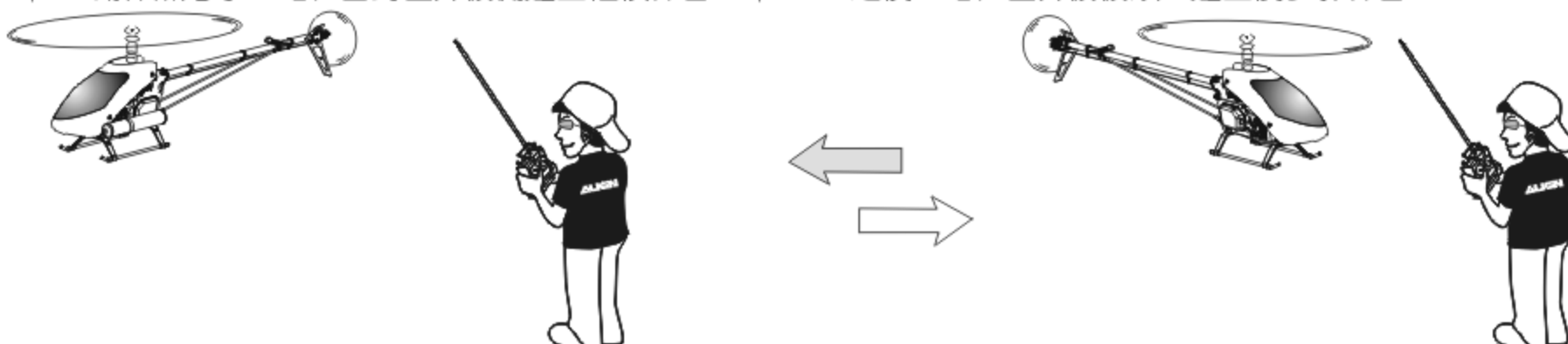

ADJUSTMENT OF EACH TRIM 飛行動作微調

Slowly raise the throttle stick and just as the helicopter lift-off the ground, you can use the trim to correct the action if the helicopter leans in a different direction.
慢慢升起油門搖桿，當直昇機剛剛離開地面時，若直昇機傾向不同方向，可使用微調修正動作。

1. Adjustment of rudder trim 調整方向舵微調

Just before the helicopter lift-off, the nose lean left/right...

When leans right, adjust the trim to left side.
When leans left, adjust the trim to right side.

在直昇機正要起飛時，機頭朝左/右方向偏移...
向右偏移時，微調向左調整。
向左偏移時，微調向右調整。

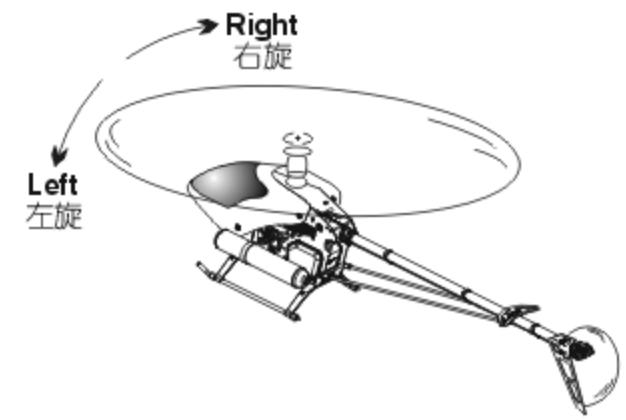
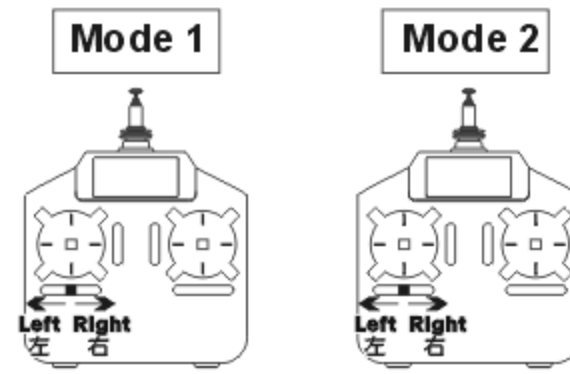

2. Adjustment of elevator trim 調整升降舵微調

Just before the helicopter lift-off, the nose lean forward/backward...

When leans forward, adjust the trim down.
When leans backward, adjust the trim up.

在直昇機正要起飛時，機頭朝前/後方向偏移...
向前偏移時，微調向下調整。
向後偏移時，微調向上調整。

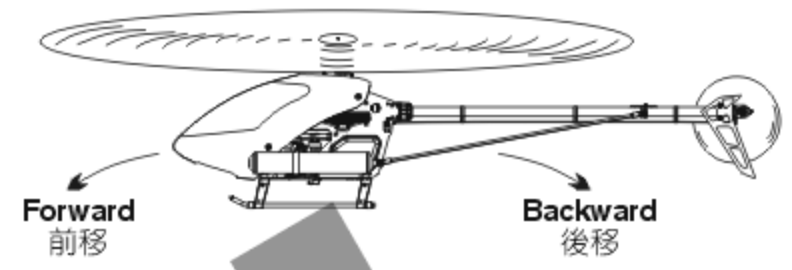
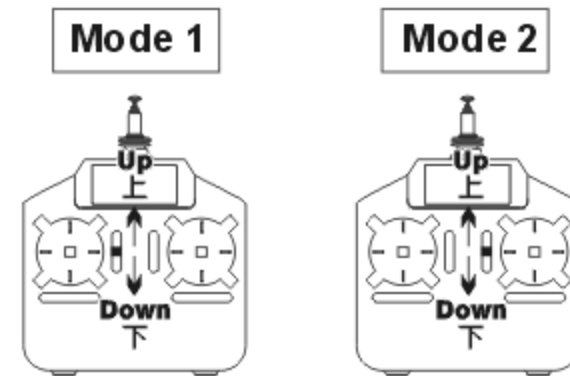

3. Adjustment of Aileron trim 調整副翼微調

Just before the helicopter lift-off, the body lean left/right...

When leans right, adjust the trim to left side.
When leans left, adjust the trim to right side.

在直昇機正要起飛時，機身朝左/右方向偏移...
向右偏移時，微調向左調整。
向左偏移時，微調向右調整。

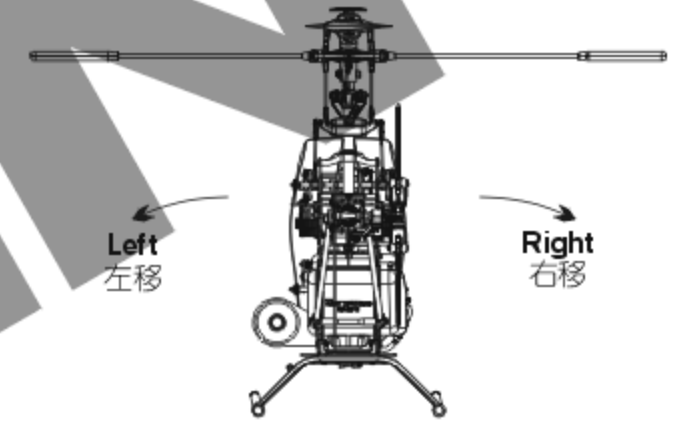
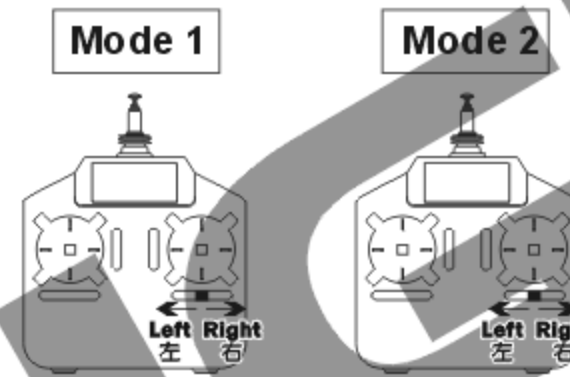

TROUBLE SHOOTING DURING FLIGHT 如何排除飛行中的狀況

	Situation 狀況	Cause 原因	Way to deal 對策
Blade Tracking 雙槳平衡	Out of tracking 雙槳	Adjustment of pitch rod has not been done. PITCH連桿長度調整不平均	Adjust the length of linkage rod(A)→Regular trim Adjust the length of linkage rod(C)→Slight trim 調整連桿(A)長度→一般調整 調整連桿(C)長度→微調整
During Hovering 停旋	Low rotation of the rotor 主旋翼轉速偏低	★ Pitch of main blade is high. ★ 主旋翼的PITCH偏高 ★ Throttle curve is too low during hovering. ★ 停旋點油門曲線過低	★ Lower the pitch about 4~5 during hovering(The rotation should be about 1,600rpm during hovering). ★ 調低Pitch停旋Pitch約4-5 (停旋時主旋翼需為約1600RPM) ★ Heighten the throttle curve during hovering. ★ 調高停旋點油門曲線
	High rotation of the rotor 主旋翼轉速偏高	★ Pitch of main blade is low. ★ 主旋翼的PITCH偏低 ★ Throttle curve is too high during hovering. ★ 停旋點油門曲線過高	★ Adjust the pitch rod <A> (The rotation should be about 1,600rpm during hovering). ★ 調整連桿 <A> (停旋時主旋翼需為約1600RPM) ★ Lower the throttle curve during hovering. ★ 調低停旋點油門曲線
Sensitivity of the gyro 陀螺儀敏感度	The tail leans to one side during hovering, or when trim the rudder and return to the neutral, the tail lags and cannot stay in a control position. 停旋時尾翼向某一邊偏移，或撥動方向舵並回復到中立點時，尾翼產生延遲，無法停頓在所控制位置上。	★ Failure setting of tail neutral point. ★ 尾中立點設定不當 ★ The sensitivity of the gyro is low. ★ 陀螺儀敏感度偏低	★ Reset tail neutral point. ★ 重設尾中立點 ★ Increase the sensitivity. ★ 增加敏感度
	The tail wags left and right during flight at hovering or full speed. 停懸或全油門時尾翼左右來回快速搖擺。	The sensitivity of the gyro is high. 陀螺儀敏感度偏高	Decrease the sensitivity. 降低敏感度

※If the problem is still there even after tried above, stop flying and consult to your seller or experienced pilot.

※在做完以上調整後，仍然無法改善情況時，應立即停止飛行並向您的經銷商或有經驗的飛手諮詢。

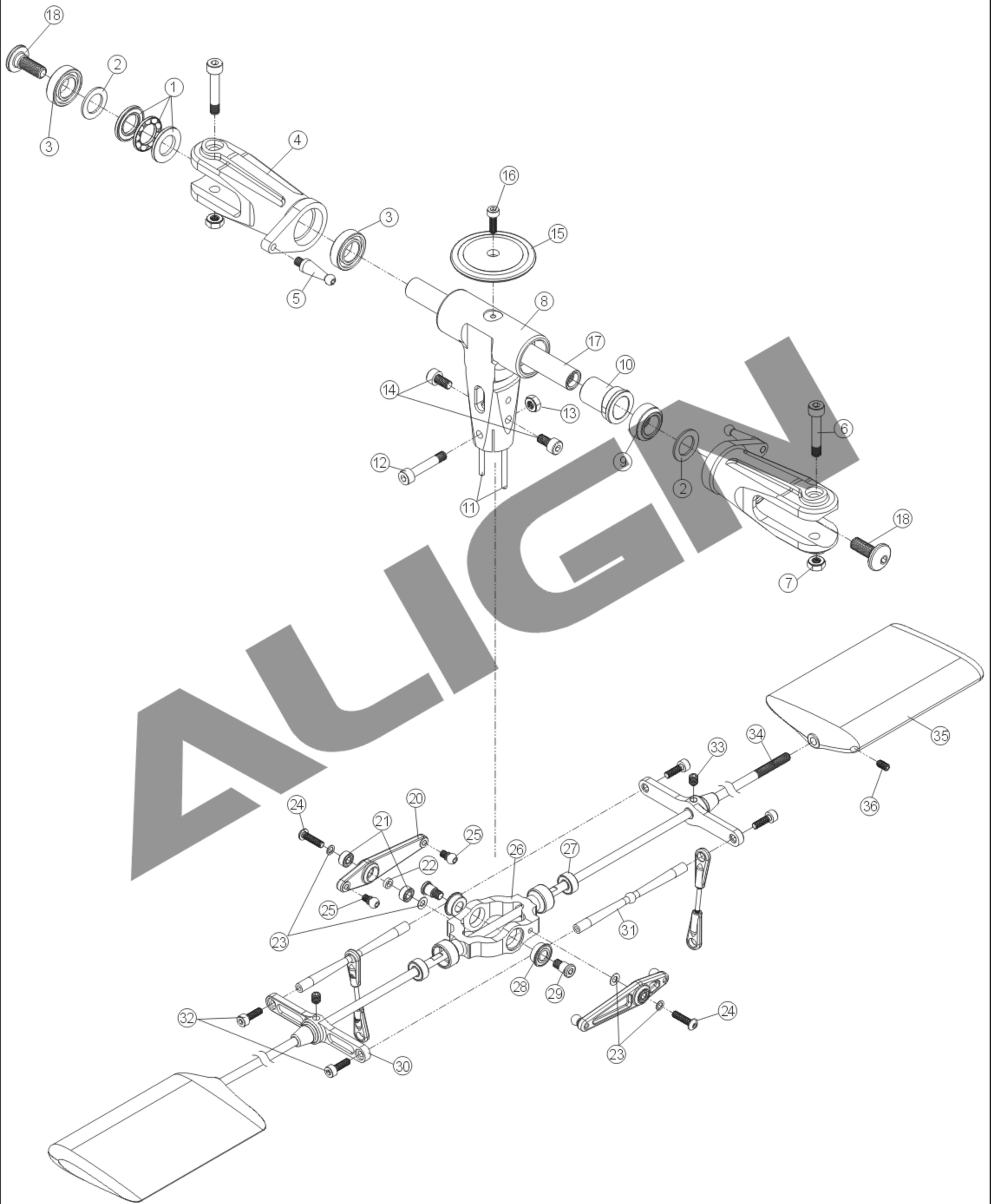

No.	Code No.	Name	Specification	Quantity	Remarks
1	HF10-18M	Thrust bearing 止推軸承	φ 10.2x φ 18x5.5mm	2	
2	90NH024	Spindle bearing spacer 橫軸止推華司	φ 10x φ 16x1mm	4	
3	50B6800ZZ-2	Bearing 6800ZZ 6800ZZ軸承	φ 10x φ 19x5mm	4	
4	90NH002	Metal main rotor holder 金屬主旋翼夾座		2	
5	90NZ001	Linkage ball A(M4x5) 球頭A (M4x5)	φ 5x24mm	2	
6	T65032	Socket collar screw 圓頭內六角軸套螺絲	M5x32mm	2	
7	N10050-3	M5 Nut M5防鬆螺帽	M5	2	
8	90NH003	Metal main rotor housing 金屬主旋翼固定座		1	
9	90NH013	Damper rubber 橫軸墊圈	φ 9.9x φ 17x7mm	2	
10	90NH005	Feathering shaft sleeve 橫軸套管	φ 10.2x φ 17x21mm	2	
11	90NH026	Pin 主軸固定插銷	φ 2.5x35mm	2	
12	90NZ006	Socket collar screw 圓頭內六角軸套螺絲	M4x24mm	1	
13	N14001	M4 Nut M4防鬆螺帽	M4	1	
14	T64008	Socket screw 圓頭內六角螺絲	M4x8mm	2	
15	90NH001	Metal head stopper 金屬旋翼頭制動器	φ 40x7.5mm	1	
16	T63010	Socket screw 圓頭內六角螺絲	M3x10mm	1	
17	90NH004	Feathering shaft 橫軸	φ 7x φ 10x106.5mm	1	
18	90NZ005	Collar screw 橫軸軸套螺絲	M6x16mm	2	
20	90NH011	Metal SF Mixing arm 金屬SF控制搖臂	φ 7x7.5x57.5mm	2	
21	50H683ZZ	Bearing 683ZZ 683ZZ軸承	φ 3x φ 7x3mm	4	
22	50H024	Collar 擺臂軸承襯套	φ 3x φ 4.8x1.5mm	2	
23	50H022-2	Washer 華司	φ 3x φ 4.8x0.3mm	4	
24	T53012-1	Socket button head screw 半圓頭內六角螺絲	M3x12mm	2	
25	90NZ003	Linkage ball C(M3x3.5) 球頭C (M3x3.5)	φ 5x8.5mm	4	
26	90NH007	Metal flybar seesaw holder 金屬平衡桿固定座	φ 10x φ 12.5x69mm	1	
27	HMR104ZZ	Bearing MR104ZZ MR104ZZ軸承	φ 4x φ 10x4mm	2	
28	HMF105ZZ	Bearing MF105ZZ MF105ZZ軸承	φ 5x φ 11.2x φ 10x4mm	2	
29	90NH023	M4 collar screw M4雙層軸套螺絲	M4x10mm	2	
30	90NH008	Metal flybar control arm 金屬平衡翼控制臂	φ 4x17x58mm	2	
31	90NH009	Flybar control rod 平衡翼球型控制球桿	φ 5x φ 4.5x71mm	2	
32	T63006	Socket screw 圓頭內六角螺絲	M3x6mm	4	
33	T74004	M4 Set screw M4止洩螺絲	M4x4mm	2	
34	90NH025	Flybar rod 平衡翼桿	φ 4x570mm	1	
35	90NH033	Flybar paddle 平衡翼		1set	
36	T73006	M3 Set screw M3止洩螺絲	M3x6mm	2	

Specifications, contents of parts and availability are subject to change, Align RC is not responsible for inadvertent errors in this publications.
 本說明書內的材質、規格或零件包裝之內容物僅供參考。本公司將不對此印刷物之異動負責，也無法主動通知消費者，任何更新或異動，請以亞拓網頁為主。

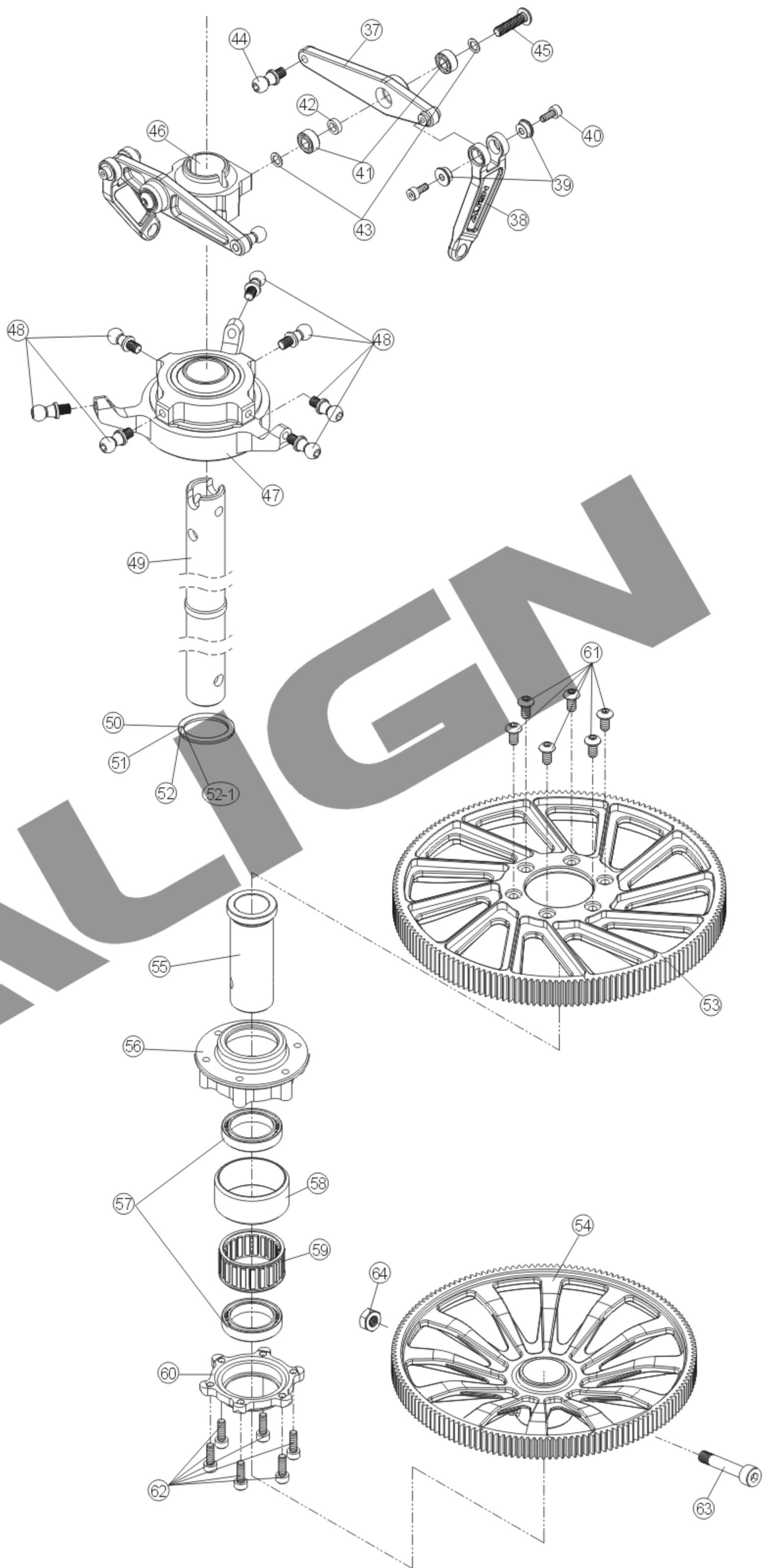

No.	Code No.	Name	Specification	Quantity	Remarks
37	90NH012	Metal washout control arm 金屬穩定控制搖臂	φ7x6.7x59.5mm	2	
38	90NH015	Radius arm Radius連桿		2	
39	FMR52ZZ	Bearing FMR52ZZ FMR52ZZ軸承	φ2xφ5x2.3mm	4	
40	T52005	Socket screw 圓頭內六角螺絲	M2x5mm	4	
41	50H683ZZ	Bearing 683ZZ 683ZZ軸承	φ3xφ7x3mm	4	
42	50H024	Collar 擺臂軸承襯套	φ3xφ4.8x1.5mm	2	
43	50H022-2	Washer 華司	φ3xφ4.8x0.3mm	4	
44	90NZ002	Linkage ball B(M3x4) 球頭B(M3x4)	φ5x12mm	2	
45	T53012-1	Socket button head screw 半圓頭內六角螺絲	M3x12mm	2	
46	90NH010	Metal washout base 金屬向位器	φ14.5x22x21mm	1	
47		CCPM Metal Swashplate 金屬CCPM十字盤組		1set	
48	90NZ002	Linkage ball B(M3x4) 球頭B(M3x4)	φ5x12mm	7	
49	90NH012	Main shaft 主軸	φ8xφ12x212.5mm	1	
50	90NH036	Main shaft spacer(1) 主軸墊片(1)	φ12xφ16x1mm	1	
51	90NH037	Main shaft spacer(1.2) 主軸墊片(1.2)	φ12xφ16x1.2mm	1	
52	90NH038	Main shaft spacer(0.8) 主軸墊片(0.8)	φ12xφ16x0.8mm	1	
52-1	90NH039	Main shaft spacer(0.5) 主軸墊片(0.5)	φ12xφ16x0.5mm	1	
53	90NB037	Main drive gear(164T) 主齒盤(164T)	164T	1	
54	90NB038	Autorotation tail drive gear(150T) 尾驅動主齒(150T)	150T	1	
55	90NB043	One-way bearing shaft 單向軸承套	φ12xφ15x41.5mm	1	
56	90NB040	One-way bearing cover 單向軸承上蓋	φ21xφ15.8x26mm	1	
57	H6702ZZ	Bearing 6702ZZ 6702ZZ軸承	φ15xφ21x4mm	2	
58	90NB042	One-way bearing collar 單向軸承外環	φ6xφ23x11.6mm	1	
59	HFE423Z	One-way bearing 單向軸承	φ15xφ23x11mm	1	
60	90NB041	One-way bearing mount 單向軸承下蓋	φ21xφ6.5x33.1mm	1	
61	T53006	Socket button head screw 半圓頭內六角螺絲	M3x6mm	6	
62	T62508	Socket screw 圓頭內六角螺絲	M2.5x8mm	6	
63	T64027	Socket collar screw 圓頭內六角軸套螺絲	M4x27mm	1	
64	N14001	M4 Nut M4防鬆螺帽	M4	1	

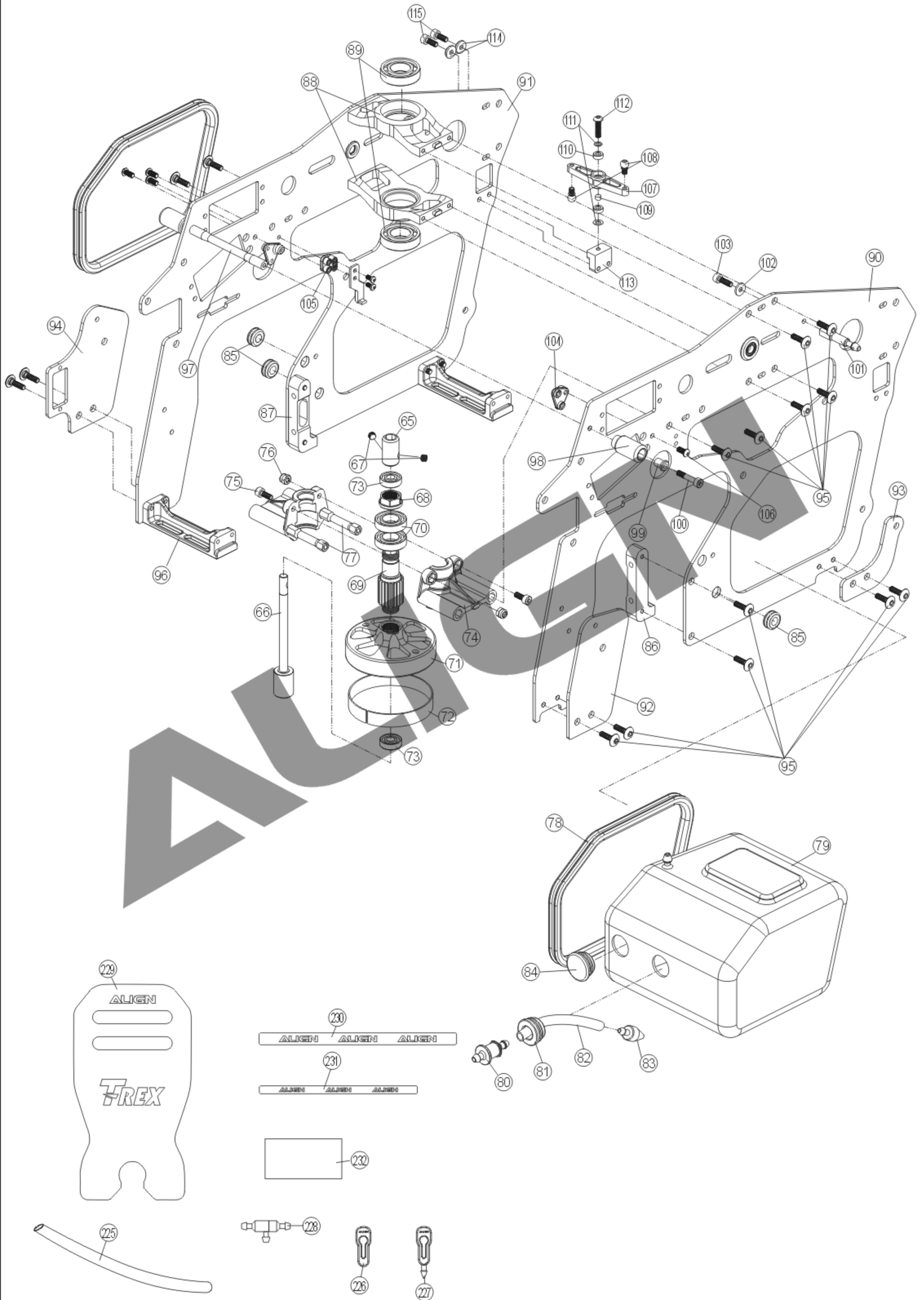

No.	Code No.	Name	Specification	Quantity	Remarks
65	50NB010	Starter coupling 六角啓動頭	φ 8x φ 10x18mm	1	
66	90NB022	Clutch/Start shaft 啓動軸	φ 5x φ 12x82mm	1	
67	T74004	M4 Set screw M4止洩螺絲	M4x4mm	2	
68	90NB021	Clutch nut 離合器齒輪螺帽	φ 14x6mm	1	
69	90NB020	Clutch gear 離合器齒輪	φ 7x φ 15.4x40.9mm	1	
70	50B6800ZZ-2	Bearing 6800ZZ 6800ZZ軸承	φ 10x φ 19x5mm	2	
71	90NB007	Clutch bell 離合器輪	φ 51x φ 56x20.5mm	1	
72	90NB047	Clutch liner 離合器來令片	1x9x158mm	1	
73	50NB695ZZ	Bearing 695ZZ 695ZZ軸承	φ 5x φ 13x4mm	2	
74	90NB014	Clutch bearing block 離合器軸承座		2	
75	T63008	Socket screw 圓頭內六角螺絲	M3x8mm	2	
76	N10030	M3 Nut M3防鬆螺帽	M3	2	
77	90NB033	Hex mounting bolt 六角機身鋁柱	φ 2.5x60.5mm	2	
78	90NB013	Fuel tank guard 油箱墊圈		2	
79	90NB012	Fuel tank 油箱		1	
80	50NB026	Fuel tank nipple 油箱接頭		1	
81	50NB030	Grommet 油箱接頭墊圈		1	
82	90NB044	Fuel tube 油管	φ 2.5x φ 4.5x70mm	1	
83	50NB027	Fuel tank sinker 油管接頭		1	
84	90NB052	Fuel tank plug 油箱塞		1	
85	50NB037	Fuel line grommet 油管保護套	φ 5.2x φ 7x φ 11x4.8mm	3	
86	90NB026	Engine mount (L) 引擎座(左)	39.3x16x8.5mm	1	
87	90NB027	Engine mount (R) 引擎座(右)	39.3x16x8.5mm	1	
88	90NH028	Main shaft block 主軸固定座		2	
89	H6901ZZ	Bearing 6901 ZZ 6901ZZ軸承	φ 12x φ 24x6mm	2	
90	90NB001	Main frame(L) 主體側板(左)		1	
91	90NB001	Main frame(R) 主體側板(右)		1	
92	90NB004	Front frame brace 側板前補強片		1	
93	90NB005	Rear frame brace 側板後補強片		2	
94	90NB003	Switch mount 側板開關補強片		1	
95	T53008-3	Socket button head collar screw 半圓頭內六角軸套螺絲	M3x8mm	24	
96	90NB025	Front frame mount 機身前固定座		2	
97	90NB032	Frame mounting bolt 機身前鋁柱		1	
98	50NB039	Canopy spacer 機頭罩支撐墊圈	φ 4.8x φ 11x22mm	2	
99	50NB038	Canopy support 機頭罩支撐柱	φ 3x φ 5x φ 6.5x7.3mm	2	
100	T53014-2	Socket screw 圓頭內六角螺絲	M3x14mm	2	
101	90NB053	Canopy mounting bolt 機頭罩固定柱		2	
102	W10030	M3 Washer M3華司	φ 3x φ 8x1mm	2	
103	T63012	Socket screw 圓頭內六角螺絲	M3x12mm	2	
104	90NB015	Servo mounting plate 伺服器固定片		2	
105	90NB017	Governor mount 定速器固定座		1	

No.	Code No.	Name	Specification	Quantity	Remarks
106	S92606	Socket button head self tapping screw 半圓頭內六角自攻螺絲	T2.6x6mm	4	
107	50NB053	Tail control arm 尾控制臂	47x9x8mm	1	
108	90NZ003	Linkage ball C(M3x3.5) 球頭C(M3x3.5)	φ 5x8.5mm	2	
109	50NB034	Collar 尾控制臂鋁套	φ 7x φ 15.4x40.9mm	1	
110	HMR63ZZ	Bearing MR63ZZ MR63ZZ軸承	φ 3x φ 4.4x3mm	2	
111	50H022-2	Washer 華司	φ 3x φ 4.8x0.3mm	2	
112	T53012-1	Socket button head screw 半圓頭內六角螺絲	M3x12mm	1	
113	50NB019	Frame mounting block 機身固定塊	14x12.5x8mm	1	
114	50B072	M3 Specialty washer M3特殊華司	φ 3x φ 8x2mm	2	
115	T63008	Socket screw 圓頭內六角螺絲	M3x8mm	2	
225	90NB045	Fuel tube 油管	φ 2.5x φ 5x500mm	1	
226	50NB043	Fuel tube clip A 油管夾片A	26x9.8x3mm	1	
227	50NB044	Fuel tube clip B 油管夾片B	33.5x9.8x3mm	1	
228	50NB054	Fuel filter 油管過濾器	3-Way	1	
229	50H137-2	Main blade holder 主旋翼固定架泡棉	165x90x15mm	1	
230	K10378	Hook and Loop Tape 魔術帶	15x250mm	1	
231	K10379	Hook and Loop Tape 魔術帶	10x200mm	1	
232	K10365	Hook and Loop Tape 魔術沾	54x28mm	3set	

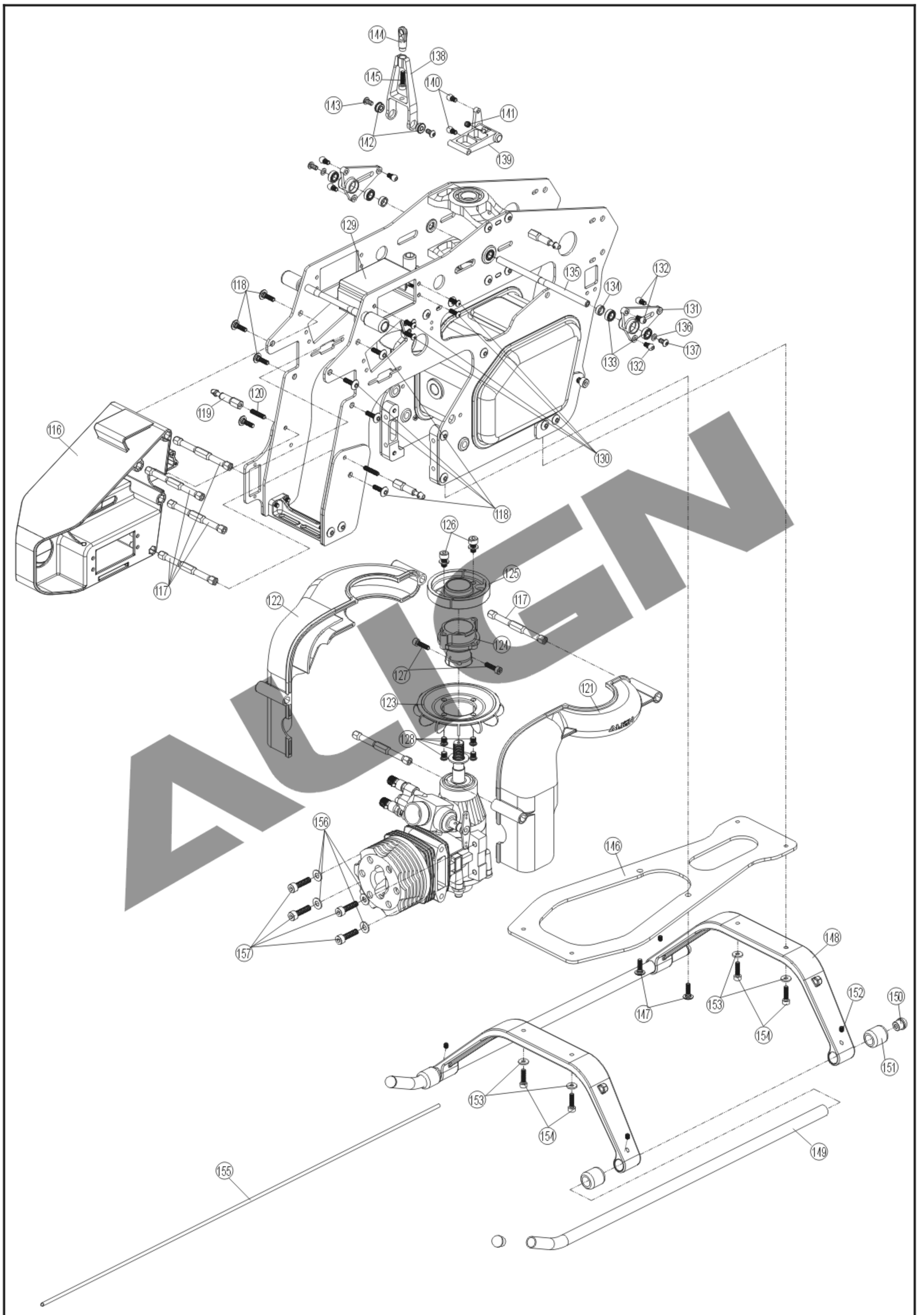

No.	Code No.	Name	Specification	Quantity	Remarks
116	90NB006	Receiver mount 接收器座		1	
117	90NB033	Hex mounting bolt 六角機身鋁柱	φ 2.5x60.5mm	6	
118	T53008-3	Socket button head collar screw 半圓頭內六角軸套螺絲	M3x8mm	10	
119	90NB053	Canopy mounting bolt 機頭罩固定柱		2	
120	T73015	Set screw 止洩螺絲	M3x15mm	2	
121	90NB011	Engine fan cover (L) 引擎風扇蓋(左)		1	
122	90NB010	Engine fan cover (R) 引擎風扇蓋(右)		1	
123	90NB008	Engine fan 引擎風葉		1	
124	90NB009	Engine fan mount 引擎風扇座		1	
125	90NB019	Clutch 離合器	φ 22x φ 48x16mm	1	
126	T64008-1	Socket head spring screw 圓頭內六角彈簧螺絲	M4x8mm	2	
127	T63012	Socket screw 圓頭內六角螺絲	M3x12mm	2	
128	T54005	Socket button head screw 半圓頭內六角螺絲	M4x5mm	4	
129	90NB016	Elevator servo mount 升降伺服器座		1	
130	S92614	Socket button head self tapping screw 半圓頭內六角自攻螺絲	T2.6x14mm	4	
131	90NB028	Aileron lever 左右控制搖臂		2	
132	90NZ003	Linkage ball C(M3x3.5) 球頭C(M3x3.5)	φ 5x8.5mm	6	
133	50BMR95ZZ	Bearing MR95ZZ MR95ZZ軸承	φ 5x φ 9x3mm	4	
134	90NB030	Control shaft collar 連動桿套圈	φ 5x φ 7.5x3mm	2	
135	90NB029	Control shaft 連動桿	φ 4.7x φ 5x98mm	1	
136	50H022	Washer 華司	φ 3x φ 5.5x0.3mm	2	
137	T53006	Socket button head screw 半圓頭內六角螺絲	M3x6mm	2	
138	90NB023	Elevator arm 升降控制臂		1	
139	90NB024	Elevator lever 升降連動控制臂		1	
140	90NZ003	Linkage ball C(M3x3.5) 球頭C(M3x3.5)	φ 5x8.5mm	2	
141	T74004	M4 Set screw M4止洩螺絲	M4x4mm	1	
142	HF683ZZ	Bearing F683ZZ F683ZZ軸承	φ 3x φ 7x3mm	2	
143	T53008-2	Socket button head screw 半圓頭內六角螺絲	M3x8mm	2	
144	90NB034-1	Elevator ball link 升降臂連桿頭		1	
145	T63012	Socket screw 圓頭內六角螺絲	M3x12mm	1	
146	90NB035	CF Bottom plate 碳纖維底板		1	
147	T53008-3	Socket button head collar screw 半圓頭內六角軸套螺絲	M3x8mm	2	
148	50F179	Landing skid 腳架	200x60.25mm	2	
149	90NF001	Skid pipe 腳架鋁管	φ 9x310mm	2	
150	50F084	Skid pipe end cap 腳架鋁管保護套		4	
151	50F130	Landing skid nut 腳架墊圈		4	
152	T73004	M3 Set screw M3止洩螺絲	M3x4mm	4	
153	W10030	M3 Washer M3華司	φ 3x φ 8x1mm	4	
154	T63012	Socket screw 圓頭內六角螺絲	M3x12mm	4	
155	50F128	Antenna pipe 天線管	φ 2x φ 3.9x500mm	1	
156	W10040	M4 Washer M4華司	φ 4x φ 10x1mm	4	
157	T64016	Socket screw 圓頭內六角螺絲	M4x16mm	4	



No.	Code No.	Name	Specification	Quantity	Remarks
158	90NT001	Tail boom mount (L)	尾管固定座(左)	1	
159	90NT002	Tail boom mount (R)	尾管固定座(右)	1	
160	90NB033	Hex mounting bolt	六角機身鋁柱 $\phi 2.5 \times 60.5 \text{mm}$	4	
161	90NT007	Long umbrella gear	軸傳長傘齒	1	
162	50T6701ZZ	Bearing 6701 ZZ	6701ZZ軸承 $\phi 12 \times \phi 18 \times 4 \text{mm}$	2	
163		Front drive gear assembly	尾傳動導輪軸組	1set	
164	50NB695ZZ	Bearing 695ZZ	695ZZ軸承 $\phi 5 \times \phi 13 \times 4 \text{mm}$	2	
165	T53014-2	Socket screw	圓頭內六角螺絲 M3x14mm	4	
166	N10030	M3 Nut	M3防鬆螺帽 M3	4	
167	T53008-3	Socket button head collar screw	半圓頭內六角軸套螺絲 M3x8mm	8	

No.	Code No.	Name	Specification	Quantity	Remarks
168	50T125-1	Tail control guide	尾控制桿固定環	3	
169	90NT012	Tail boom	尾管	1	
170	90NT028	Tail rudder control rod B	尾舵控制連桿B	1	
171	90NZ035	Ball link	連桿頭	2	
172	90NT024	3K CF Horizontal stabilizer	3K碳纖水平翼	1	
173	90NT023	3K CF Vertical stabilizer	3K碳纖垂直翼	1	
174	90NT025	Stabilizer mount(Upper)	水平翼固定座(上)	1	
175	90NT026	Stabilizer mount(Lower)	水平翼固定座(下)	1	
176	50B072	M3 Specialty washer	M3特殊華司	4	
177	T63022	Socket collar screw	圓頭內六角軸套螺絲	2	
178	T63026	Socket screw	圓頭內六角螺絲	2	
179		Torque tube set	尾傳動軸桿組	1	
180	50T193	Torque tube bearing holder	尾傳動軸承墊圈	2	
181	90NB031	Frame mounting bolt	機身後鋁柱	1	
182	90NT029	Tail boom brace	尾管支撐架	2	
183	90NT005	Tail boom brace end	尾管支撐架接頭	4	
184	W10040-1	M4 Washer	M4華司	4	
185	T64016	Socket screw	圓頭內六角螺絲	2	
186	T64012	Socket screw	圓頭內六角螺絲	2	
187		Torque tube drive tail unit	尾軸傳尾齒箱	1	
188	90NT011	Vertical stabilizer mount	垂直翼固定座	1	
189	90NT014	Metal plate(L)	尾齒箱左側板	1	
190	90NT015	Metal plate(R)	尾齒箱右側板	1	
191	90NT017	Aluminum bolt	尾齒箱固定鋁柱	1	
192	90NT016	Control arm mounting bolt	尾控制臂固定座	1	
193		Tail rotor shaft assembly	尾橫軸組	1	
194	HMR126ZZ	Bearing MR126ZZ	MR126ZZ軸承	2	
195	T53006	Socket button head screw	半圓頭內六角螺絲	6	
196	T52506	Socket button head screw	半圓頭內六角螺絲	1	
197	90NT006	Tail rotor control arm	尾舵控制L臂	1	
198	90NT018	Collar	尾控制臂鋁套	1	
199	50H683ZZ	Bearing 683ZZ	683ZZ軸承	2	
200	50H022-2	Washer	華司	2	
201	T63020	Socket collar screw	圓頭內六角軸套螺絲	1	
202	90NZ004	Linkage ball C(M2x5)	球頭C(M2x5)	1	
203	N10020-1	M2 Nut	M2尼帽	1	
204	90NT021	Slide shaft	尾軸滑套	1	
205	90NT019	Bearing holder	尾控制軸承套	1	
206	90NT020	Collar	尾控制套墊圈	1	
207	HMR128ZZ	Bearing MR128ZZ	MR128ZZ軸承	2	
208	90NZ003	Linkage ball C(M3x3.5)	球頭C(M3x3.5)	1	
209	90NT022	T type arm	尾T型控制臂	1	
210	50T105-1	Control link	尾控制連桿頭	2	
211	50T106	Collar A	尾連桿頭銅套A	2	
212	50T127	Collar B	尾連桿頭銅套B	2	
213	T12008-4	Collar screw	軸套螺絲	4	
214	T52008	Socket screw	圓頭內六角螺絲	2	
215	50T171	Tail rotor holder	尾旋翼夾座	2	
216	50T172	Tail rotor hub	尾旋翼T型座	1	
217	50TMR105ZZ-1	Bearing MR105ZZ	MR105ZZ軸承	2	
218	50TF510M	Thrust bearing	止推軸承	2	
219	W10030-1	Washer	華司	2	
220	T63008	Socket screw	圓頭內六角螺絲	2	
221	T74004	M4 Set screw	M4止洩螺絲	1	
222	KU110016	3K CF Tail blade	3K碳纖尾旋翼	2	
223	T63020	Socket collar screw	圓頭內六角軸套螺絲	2	
224	N10030	M3 Nut	M3防鬆螺帽	2	



Specifications & Equipment/規格配備:

Length/機身長: 1335mm

Height/機身高: 450mm

Main Blade Length/主旋翼長: 690~710mm

Main Rotor Diameter/主旋翼直徑: 1562~1602mm

Tail Rotor Diameter/尾旋翼直徑: 281mm

Engine Pinion Gear/引擎主齒: 20T

Autorotation Tail Drive Gear/尾驅動主齒: 150T

Drive Gear Ratio/齒輪傳動比: 8.2:1:4.54(E:M:T)

Fuel Tank Capacity /油箱容量 : 630cc.

Weight(Without Power System)/空機重: Approx. 3.2kg

