

# Nitro T-REX 600

LIMITED EDITION

ALIGN

## INSTRUCTION MANUAL

## 使用說明書

KX0160NPTL



<b>Contents</b>	
<b>1</b>	INTRODUCTION 前言
<b>1~2</b>	SAFETY NOTES 安全注意事項
<b>3</b>	EQUIPMENT REQUIRED FOR ASSEMBLY 自備設備
<b>4</b>	SAFETY CHECK BEFORE FLYING 飛行前安全檢查
<b>5~21</b>	ASSEMBLY SECTION 組裝說明
<b>22</b>	EQUIPMENT INSTALLATION 各項設備配置圖
<b>23</b>	SERVO AND LINKAGE ROD SETTING ILLUSTRATION 伺服器與連桿設定視圖
<b>23</b>	CANOPY ASSEMBLY 機頭罩安裝
<b>24</b>	ELECTRIC EQUIPMENT ILLUSTRATION 電子設備建議配置圖示
<b>25</b>	SERVO SETTING AND ADJUSTMENT 伺服器設定調整
<b>25</b>	ADJUSTMENTS FOR GYRO AND TAIL NEUTRAL SETTING 陀螺儀與尾翼中立點調整
<b>26</b>	PITCH AND THROTTLE SETTING 主旋翼螺距與油門設定
<b>27~28</b>	GOVERNOR INSTRUCTION MANUAL 定速器安裝使用說明
<b>29</b>	2 IN 1 VOLTAGE REGULATOR INSTRUCTION MANUAL 2合1降壓器安裝使用說明
<b>30~32</b>	GP780 HEAD LOCK SET USER MANUAL GP780鎖定式陀螺儀組使用說明
<b>32~36</b>	FLIGHT ADJUSTMENT AND SETTING 飛行動作調整與設定
<b>37~46</b>	PART NAMES AND OPTIONAL PART LIST 各部零件名稱與選購備品明細



Thank you for buying ALIGN products. The **T-REX 600N** is the latest technology in Rotary RC models. Please read this manual carefully before assembling and flying the new **T-REX 600N** helicopter. We recommend that you keep this manual for future reference regarding tuning and maintenance.

承蒙閣下選用亞拓遙控世界系列產品，謹表謝意。進入遙控世界之前必須告訴您許多相關的知識與注意事項，以確保您能夠在學習的過程中較得心應手。在開始操作之前，請務必詳閱本說明書，相信一定能夠給您帶來相當大的幫助，也請您妥善保管這本說明書，以作為日後參考。

Thank you for buying ALIGN Products. The T-REX 600N Helicopter is designed as an easy to use, full featured Helicopter R/C model capable of all forms of rotary flight. Please read the manual carefully before assembling the model, and follow all precautions and recommendations located within the manual. Be sure to retain the manual for future reference, routine maintenance, and tuning. The T-REX 600N is a new product developed by ALIGN. It provides flying stability for beginners, full aerobatic capability for advanced fliers, and unsurpassed reliability for customer support.

感謝您選購亞拓產品，為了讓您容易方便的使用 T-REX 600N 直昇機、請您詳細的閱讀完這本說明書之後再進行組裝以及操作這台直昇機，同時請您妥善的保存這本說明書、作為日後進行調整以及維修的參考。T-REX 600N 是由亞拓自行研發的新產品，不論你是需求飛行穩定性的初學者或是追求性能的飛行愛好者。T-REX 600N 將是你最佳的選擇。

### THE MEANING OF SYMBOLS 標誌代表涵義

 <b>WARNING</b> 警告	<b>Mishandling due to failure to follow these instructions may result in damage or injury.</b> 因為疏忽這些操作說明，而使用錯誤可能造成財產損失或嚴重傷害。
 <b>CAUTION</b> 注意	<b>Mishandling due to failure to follow these instructions may result in danger.</b> 因為疏忽這些操作說明，而使用錯誤可能造成危險。
 <b>FORBIDDEN</b> 禁止	<b>Do not attempt under any circumstances.</b> 在任何禁止的環境下，請勿嘗試操作。

### IMPORTANT NOTES 重要聲明

**R/C helicopters, including the T-REX 600N are not toys. R/C helicopter utilize various high-tech products and technologies to provide superior performance. Improper use of this product can result in serious injury or even death. Please read this manual carefully before using and make sure to be conscious of your own personal safety and the safety of others and your environment when operating all ALIGN products.**

**Manufacturer and seller assume no liability for the operation or the use of this product.**

**Intended for use only by adults with experience flying remote control helicopters at a legal flying field. After the sale of this product we cannot maintain any control over its operation or usage.**

T-REX 600N 遙控直昇機並非玩具，它是結合了許多高科技產品所設計出來的休閒用品，所以商品的使用不當或不熟悉都可能造成嚴重傷害甚至死亡，使用之前請務必詳讀本說明書，勿輕忽並注意自身安全。注意!任何遙控直昇機的使用，製造商和經銷商是無法對使用者於零件使用的損耗異常或組裝不當所發生之意外負任何責任，本產品是提供給有操作過模型直昇機經驗的成人或有相當技術的人員在旁指導於當地合法遙控飛行場飛行，以確保安全無虞下操作使用，產品售出後本公司將不負任何操作和使用控制上的任何性能與安全責任。

**We recommend that you obtain the assistance of an experienced pilot before attempting to fly our products for the first time. A local expert is the best way to properly assemble, setup, and fly your model for the first time. The T-REX 600N requires a certain degree of skill to operate, and is a consumer item. Any damage or dissatisfaction as a result of accidents or modifications are not covered by any warranty and cannot be returned for repair or replacement. Please contact our distributors for free technical consultation and parts at discounted rates when you experience problems during operation or maintenance.**

模型商品屬於需高操作技術且為消耗性之商品，如經拆裝使用後，會造成不等情況零件損耗，任何使用情況所造成商品不良或不滿意，將無法於保固條件內更換新品或退貨，如遇有使用操作維修問題，本公司全省分公司或代理商將提供技術指導、特價零件供應服務。

## 2. SAFETY NOTES 安全注意事項



**Fly only in safe areas, away from other people. Do not operate R/C aircraft within the vicinity of homes or crowds of people. R/C aircraft are prone to accidents, failures, and crashes due to a variety of reasons including, lack of maintenance, pilot error, and radio interference. Pilots are responsible for their actions and damage or injury occurring during the operation or as of a result of R/C aircraft models.**

遙控模型飛機、直昇機屬高危險性商品，飛行時務必遠離人群，人為組裝不當或機件損壞、電子控制設備不良，以及操控上的不熟悉、都有可能導致飛行失控損傷等不可預期的意外，請飛行者務必注意飛行安全，並需了解自負疏忽所造成任何意外之責任。



### LOCATE AN APPROPRIATE LOCATION 遠離障礙物及人群

R/C helicopters fly at high speed, thus posing a certain degree of potential danger. Choose an a legal flying field consisting of flat, smooth ground without obstacles. Do not fly near buildings, high voltage cables, or trees to ensure the safety of yourself, others and your model. For the first practice, please choose a legal flying field and can use a training skid to fly for reducing the damage. Do not fly your model in inclement weather, such as rain, wind, snow or darkness.

直昇機飛行時具有一定的速度，相對的也潛在著危險性，場地的選擇也相對的重要，請需遵守當地法規到合法搖控飛行場地飛行。必須注意周遭有沒有人、高樓、建築物、高壓電線、樹木等等，避免操控的不當造成自己與他人財產的損壞。初次練習時，務必選擇在空曠合法專屬飛行場地並適當搭配練習架練習飛行，這對飛行失誤所造成的損傷將會大幅的降低。請勿在下雨、打雷等惡劣天候下操作，以確保本身及機體的安全。



### PREVENT MOISTURE 遠離潮濕環境

R/C models are composed of many precision electrical components. It is critical to keep the model and associated equipment away from moisture and other contaminants. The introduction or exposure to water or moisture in any form can cause the model to malfunction resulting in loss of use, or a crash. Do not operate or expose to rain or moisture.

直昇機內部也是由許多精密的電子零組件組成，所以必須絕對的防止潮濕或水氣，避免在浴室或雨天時使用，防止水氣進入機身內部而導致機件及電子零件故障而引發不可預期的意外！



### PROPER OPERATION 勿不當使用本產品

Please use the replacement of parts on the manual to ensure the safety of instructors. This product is for R/C model, so do not use for other purpose.

請勿自行改造加工，任何的升級改裝或維修，請使用亞拓產品目錄中的零件，以確保結構的安全。請確認於產品限界內操作，請勿過載使用，並勿用於安全、法令外其它非法用途。



### OBTAIN THE ASSISTANCE OF AN EXPERIENCED PILOT 避免獨自操控

Before turning on your model and transmitter, check to make sure no one else is operating on the same frequency. Frequency interference can cause your model, or other models to crash. The guidance provided by an experienced pilot will be invaluable for the assembly, tuning, trimming, and actual first flight. (Recommend you to practice with computer-based flight simulator.)

至飛行場飛行前，需確認是否有相同頻率的好手正進行飛行，因為開啓相同頻率的發射機將導致自己與他人立即干擾等意外危險。遙控飛機操控技巧在學習初期有著一定的難度，要盡量避免獨自操作飛行，需有經驗的人士在旁指導，才可以操控飛行。(勤練電腦模擬器及老手指導是入門必要的選擇)

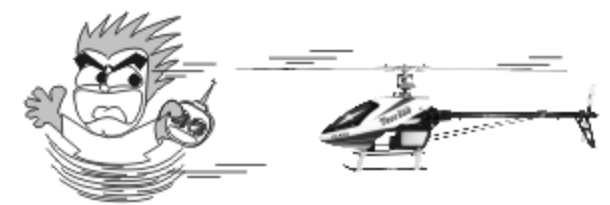

### SAFE OPERATION 安全操作

Operate this unit within your ability. Do not fly under tired condition and improper operation may cause in danger.

請於自己能力內及需要一定技術範圍內操作這台直昇機，過於疲勞、精神不佳或不當操作，意外發生風險將可能會提高。



### ALWAYS BE AWARE OF THE ROTATING BLADES 遠離運轉中零件

During the operation of the helicopter, the main rotor and tail rotor will be spinning at a high rate of speed. The blades are capable of inflicting serious bodily injury and damage to the environment. Be conscious of your actions, and careful to keep your face, eyes, hands, and loose clothing away from the blades. Always fly the model a safe distance from yourself and others, as well as surrounding objects. Never take your eyes off the model or leave it unattended while it is turned on. Immediately turn off the model and transmitter when you have landed the model.

當直昇機主旋翼與尾旋翼運轉時，切勿觸摸並遠離任何物件，以避免造成危險及損壞。



### KEEP AWAY FROM HEAT 遠離熱源

R/C models are made up various forms of plastic. Plastic is very susceptible to damage or deformation due to extreme heat and cold climate. Make sure not to store the model near any source of heat such as an oven, or heater. It is best to store the model indoors, in a climate-controlled, room temperature environment.





遙控飛機多半是以 PA 纖維或聚乙烯、電子商品為主要材質，因此要盡量遠離熱源、日曬，以避免因高溫而變形甚至熔毀損壞的可能。



RADIO TRANSMITTER AND ELECTRONIC EQUIPMENT REQUIRED FOR ASSEMBLY 自備遙控及電子設備

 <p><b>Transmitter</b> (7-channel or more, helicopter system) 發射機 (七動以上直昇機模式遙控器)</p>	 <p><b>Receiver (7-channel or more)</b> 接收機 (七動以上)</p>	 <p><b>Standard Servo x 1 pc</b> 標準伺服器 x 1</p>
 <p><b>ALIGN 50 Engine</b> ALIGN 50引擎</p>	 <p><b>50 Muffler</b> 50高效加速管</p>	 <p><b>Pitch Gauge x1 pc</b> 螺距規x1</p>
 <p><b>Super Starter x 1 pc</b> 啟動器 x 1</p>	 <p><b>Engine Fuel x1 pc</b> 引擎燃油x1</p>	 <p><b>Fuel Pump x1 pc</b> 加油器x1</p>

ADDITIONAL TOOLS REQUIRED FOR ASSEMBLY 自備工具

 <p><b>Scissors</b> 剪刀</p>	 <p><b>Cutter Knife</b> 刀子</p>	 <p><b>Diagonal Cutting Pliers</b> 斜口鉗</p>	 <p><b>Needle Nose Pliers</b> 尖嘴鉗</p>
 <p><b>Oil</b> 潤滑油</p>	 <p><b>CA</b> 瞬間膠</p>	 <p><b>Hexagon Screw Driver</b> 六角螺絲起子 3mm/2.5mm/2mm/1.5mm</p>	 <p><b>Philips Screw Driver</b> 十字螺絲起子 φ 3.0/φ 1.8mm</p>

**CAREFULLY INSPECT BEFORE REAL FLIGHT 實機飛行前請嚴格執行飛行前檢查義務**

- ☆ **Before flying, please check to make sure no one else is operating on the same frequency for the safety.**
  - ☆ **Before flight, please check if the batteries of transmitter and receiver are enough for the flight.**
  - ☆ **Before turn on the transmitter, please check if the throttle stick is in the lowest position. IDLE switch is OFF.**
  - ☆ **When turn off the unit, please follow the power on/off procedure. Power ON- Please turn on the transmitter first, and then turn on receiver. Power OFF- Please turn off the receiver first and then turn off the transmitter. Improper procedure may cause out of control, so please to have this correct habit.**
  - ☆ **Before operation, check every movement is smooth and directions are correct. Carefully inspect servos for interference and broken gear.**
  - ☆ **Check for missing or loose screws and nuts. See if there is any cracked and incomplete assembly of parts. Carefully check main rotor blades and rotor holders. Broken and premature failures of parts possibly cause resulting in a dangerous situation.**
  - ☆ **Check all ball links to avoid excess play and replace as needed. Failure to do so will result in poor flight stability.**
  - ☆ **Check the battery and power plug are fastened. Vibration and violent flight may cause the plug loose and result out of control.**
- ★ 每次飛行前應先確認所使用的頻率是否會干擾他人，以確保你自身與他人的安全。
- ★ 每次飛行前確定您發射機與接收機電池的電量是在足夠飛行的狀態。
- ★ 開機前確認油門搖桿是否位於最低點，熄火降落開關，定速開關(IDLE)是否於關閉位置。
- ★ 關機時必須遵守電源開關機的程序，開機時應先開啓發射機後，再開啓接收機電源；關機時應先關閉接收機後，再關閉發射機電源。不正確的開關程序可能會造成失控的現象，影響自身與他人的安全，請養成正確的習慣。
- ★ 開機請先確定直昇機的各個動作是否順暢，及方向是否正確，並檢查伺服器的動作是否有干涉或崩齒的情形，使用故障的伺服器將導致不可預期的危險。
- ★ 飛行前確認沒有缺少或鬆脫的螺絲與螺帽，確認沒有組裝不完整或損毀的零件，仔細檢查主旋翼是否有損壞，特別是接近主旋翼夾座的部位。損壞或組裝不完整的零件不僅影響飛行，更會造成不可預期的危險。注意：對損耗、有裂痕零件更新及定期保養檢查的重要性。
- ★ 檢查所有的連桿頭是否有鬆脫的情形，過鬆的連桿頭應先更新，否則將造成直昇機無法操控的危險。
- ★ 確認電池及電源接頭是否固定牢靠，飛行中的震動或激烈的飛行，可能造成電源接頭鬆脫而造成失控的危險。

**Standard Equipment 標準配備**

								
<b>600NC</b>	<b>600NB6</b>	<b>600NB1</b>	<b>600NB2</b>	<b>600NB3</b>	<b>600NB4</b>	<b>600NH</b>	<b>600NG</b>	<b>600NT1</b>
								
<b>600NT2</b>	<b>600NT3</b>	<b>600NZ</b>	<b>DS610 Digital Servo x 3</b> DS610數位伺服器 x 3	<b>GP780 Head Lock Gyro Combo</b> GP780鎖定式陀螺儀組(GP780+DS620)	<b>2 In 1 Voltage Regulator Combo</b> 二合一降壓器Combo	<b>RCE-G600 Governor</b> RCE-G600定速器	<b>600D Carbon Fiber Blade</b> 600D碳纖主旋翼	

**When you see the marks as below, please use glue or grease to ensure flying safety.**

標有下符號之組裝步驟，請配合上膠或上油，以確保使用之可靠度。



- CA: Apply CA Glue to fix.**
- R48: Apply Anaerobics Retainer to fix.**
- T43: Apply Thread Lock to fix.**
- OIL: Add Grease.**
- CA: 使用瞬間膠固定
- R48: 使用金屬管狀固定缺氧膠固定
- T43: 使用螺絲膠
- OIL: 添加潤滑油

**When assembling ball links, make sure the "A" character faces outside.**

各項塑膠製連桿頭扣接時，A字請朝外。

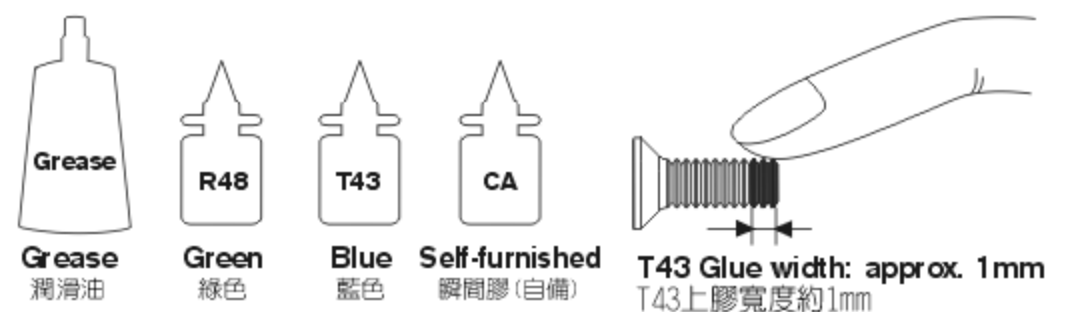

**R48 metal tubular adhesive (eg. Bearings). T43 thread lock, apply a small amount on screws or metal parts and wipe surplus off. When disassembling, recommend to heat the metal joint about 15 Seconds.(NOTE: Keep plastic parts away from heat.)**

R48 為強力金屬管狀(如軸承)接著劑，T43為螺絲膠，膠合螺絲或金屬內外徑請務必少量使用，必要時請用手去除多餘膠量，欲拆卸時可於金屬接合部位熱烤約15秒。(注意！塑膠件避免接近熱源)

**CAREFULLY INSPECT BEFORE REAL FLIGHT 實機飛行前請嚴格執行飛行前檢查義務**

- ☆ **Before flying, please check to make sure no one else is operating on the same frequency for the safety.**
  - ☆ **Before flight, please check if the batteries of transmitter and receiver are enough for the flight.**
  - ☆ **Before turn on the transmitter, please check if the throttle stick is in the lowest position. IDLE switch is OFF.**
  - ☆ **When turn off the unit, please follow the power on/off procedure. Power ON- Please turn on the transmitter first, and then turn on receiver. Power OFF- Please turn off the receiver first and then turn off the transmitter. Improper procedure may cause out of control, so please to have this correct habit.**
  - ☆ **Before operation, check every movement is smooth and directions are correct. Carefully inspect servos for interference and broken gear.**
  - ☆ **Check for missing or loose screws and nuts. See if there is any cracked and incomplete assembly of parts. Carefully check main rotor blades and rotor holders. Broken and premature failures of parts possibly cause resulting in a dangerous situation.**
  - ☆ **Check all ball links to avoid excess play and replace as needed. Failure to do so will result in poor flight stability.**
  - ☆ **Check the battery and power plug are fastened. Vibration and violent flight may cause the plug loose and result out of control.**
- ★ 每次飛行前應先確認所使用的頻率是否會干擾他人，以確保你自身與他人的安全。
- ★ 每次飛行前確定您發射機與接收機電池的電量是在足夠飛行的狀態。
- ★ 開機前確認油門搖桿是否位於最低點，熄火降落開關，定速開關(IDLE)是否於關閉位置。
- ★ 關機時必須遵守電源開關機的程序，開機時應先開啓發射機後，再開啓接收機電源；關機時應先關閉接收機後，再關閉發射機電源。不正確的開關程序可能會造成失控的現象，影響自身與他人的安全，請養成正確的習慣。
- ★ 開機請先確定直昇機的各個動作是否順暢，及方向是否正確，並檢查伺服器的動作是否有干涉或崩齒的情形，使用故障的伺服器將導致不可預期的危險。
- ★ 飛行前確認沒有缺少或鬆脫的螺絲與螺帽，確認沒有組裝不完整或損毀的零件，仔細檢查主旋翼是否有損壞，特別是接近主旋翼夾座的部位。損壞或組裝不完整的零件不僅影響飛行，更會造成不可預期的危險。注意：對損耗、有裂痕零件更新及定期保養檢查的重要性。
- ★ 檢查所有的連桿頭是否有鬆脫的情形，過鬆的連桿頭應先更新，否則將造成直昇機無法操控的危險。
- ★ 確認電池及電源接頭是否固定牢靠，飛行中的震動或激烈的飛行，可能造成電源接頭鬆脫而造成失控的危險。

**Standard Equipment 標準配備**

								
600NC	600NB6	600NB1	600NB2	600NB3	600NB4	600NH	600NG	600NT1
								
600NT2	600NT3	600NZ	DS610 Digital Servo x 3 DS610數位伺服器 x 3	GP780 Head Lock Gyro Combo GP780鎖定式陀螺儀組(GP780+DS620)	2 In 1 Voltage Regulator Combo 二合一降壓器Combo	RCE-G600 Governor RCE-G600定速器	600D Carbon Fiber Blade 600D碳纖主旋翼	

**When you see the marks as below, please use glue or grease to ensure flying safety.**

標有下符號之組裝步驟，請配合上膠或上油，以確保使用之可靠度。



- CA: Apply CA Glue to fix.
- R48: Apply Anaerobics Retainer to fix.
- T43: Apply Thread Lock to fix.
- OIL: Add Grease.
- CA: 使用瞬間膠固定
- R48: 使用金屬管狀固定缺氧膠固定
- T43: 使用螺絲膠
- OIL: 添加潤滑油

**When assembling ball links, make sure the "A" character faces outside.**

各項塑膠製連桿頭扣接時，A字請朝外。



Grease  
潤滑油



R48  
綠色



T43  
藍色



CA  
瞬間膠(自備)

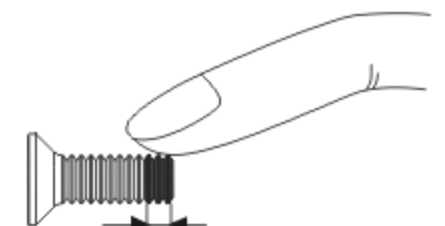

T43 Glue width: approx. 1mm  
T43上膠寬度約1mm

**R48 metal tubular adhesive (eg. Bearings). T43 thread lock, apply a small amount on screws or metal parts and wipe surplus off. When disassembling, recommend to heat the metal joint about 15 Seconds.(NOTE: Keep plastic parts away from heat.)**

R48 為強力金屬管狀(如軸承)接著劑，T43為螺絲膠，膠合螺絲或金屬內外徑請務必少量使用，必要時請用手去除多餘膠量，欲拆卸時可於金屬接合部位熱烤約15秒。(注意！塑膠件避免接近熱源)

# 600NH7A

Apply a little amount of T43 thread lock when fixing a metal part.  
螺絲鎖附於金屬件請使用適量T43(螺絲膠)

- Linkage ball A(M3x4)**  
球頭A (M3x4) (φ4.75x8.68mm) x 2
- Linkage ball B(M3x3)**  
球頭B (M3x3) (φ4.75x9.77mm) x 2
- Socket button head screw**  
半圓頭內六角螺絲(M3x12mm) x 2
- M3 collar screw**  
M3雙層軸套螺絲(M3x9.6mm) x 2
- Washer**  
華司(φ3xφ4.8x0.3mm) x 4
- Linkage rod(B)**  
連桿(B) φ2x19mm x 2
- Ball link**  
連桿頭 x 4

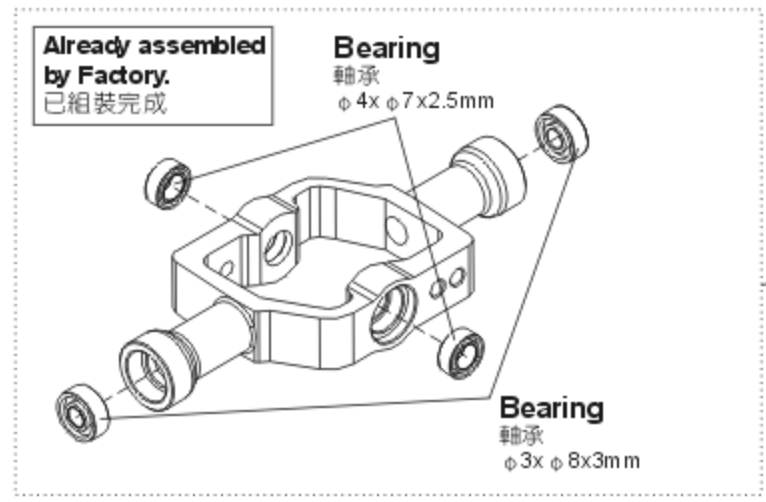
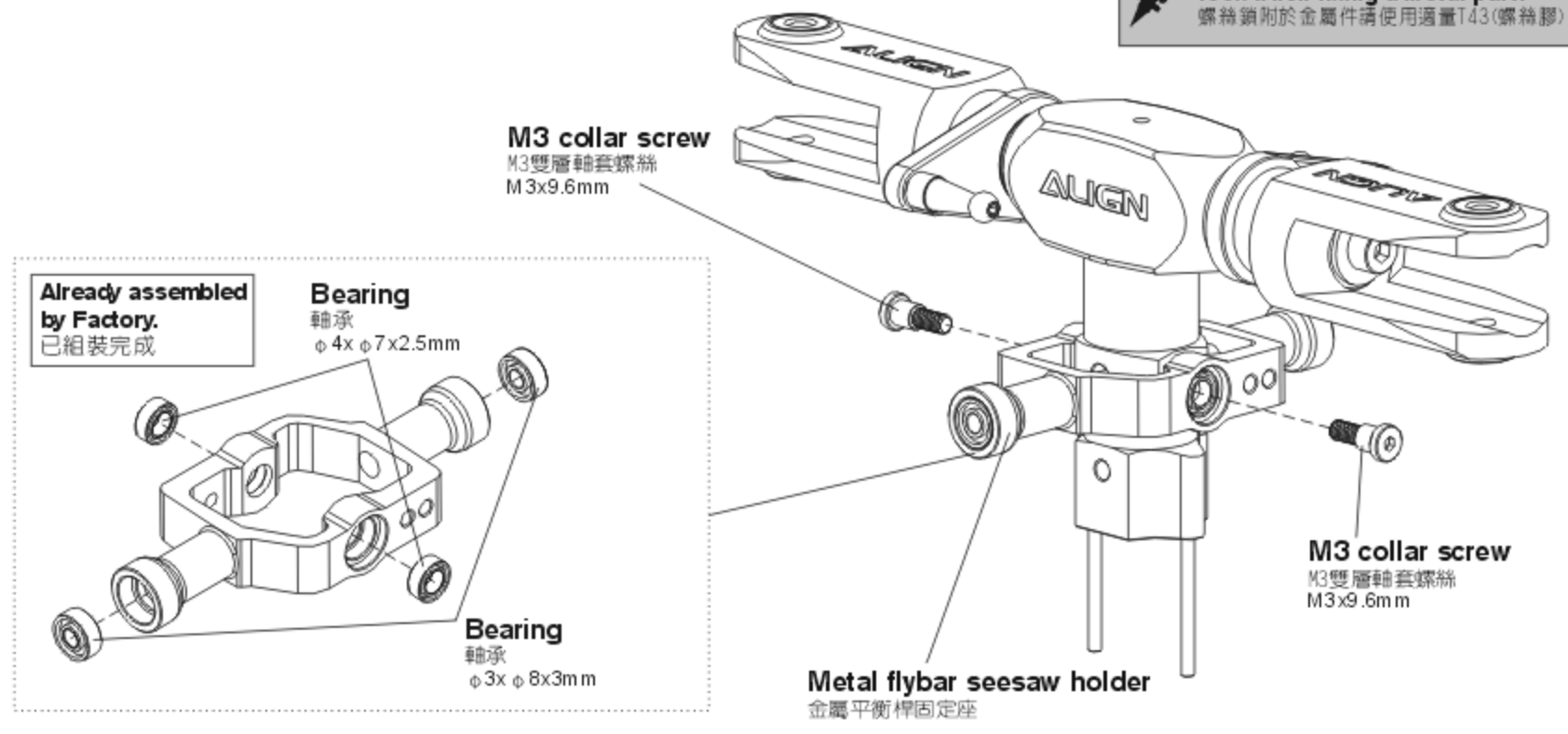

# 600NH7

- Collar**  
窄臂軸承襯套(φ3xφ4.8x1.5mm) x 2
- Bearing**  
軸承(φ3xφ8x3mm) x 2
- Bearing**  
軸承(φ3xφ7x3mm) x 4
- Bearing**  
軸承(φ4xφ7x2.5mm) x 2
- M3 Set screw**  
M3止洩螺絲(M3x3mm) x 4
- M4 Set screw**  
M4止洩螺絲(M4x4mm) x 2
- Socket screw**  
圓頭內六角螺絲(M3x5mm) x 4

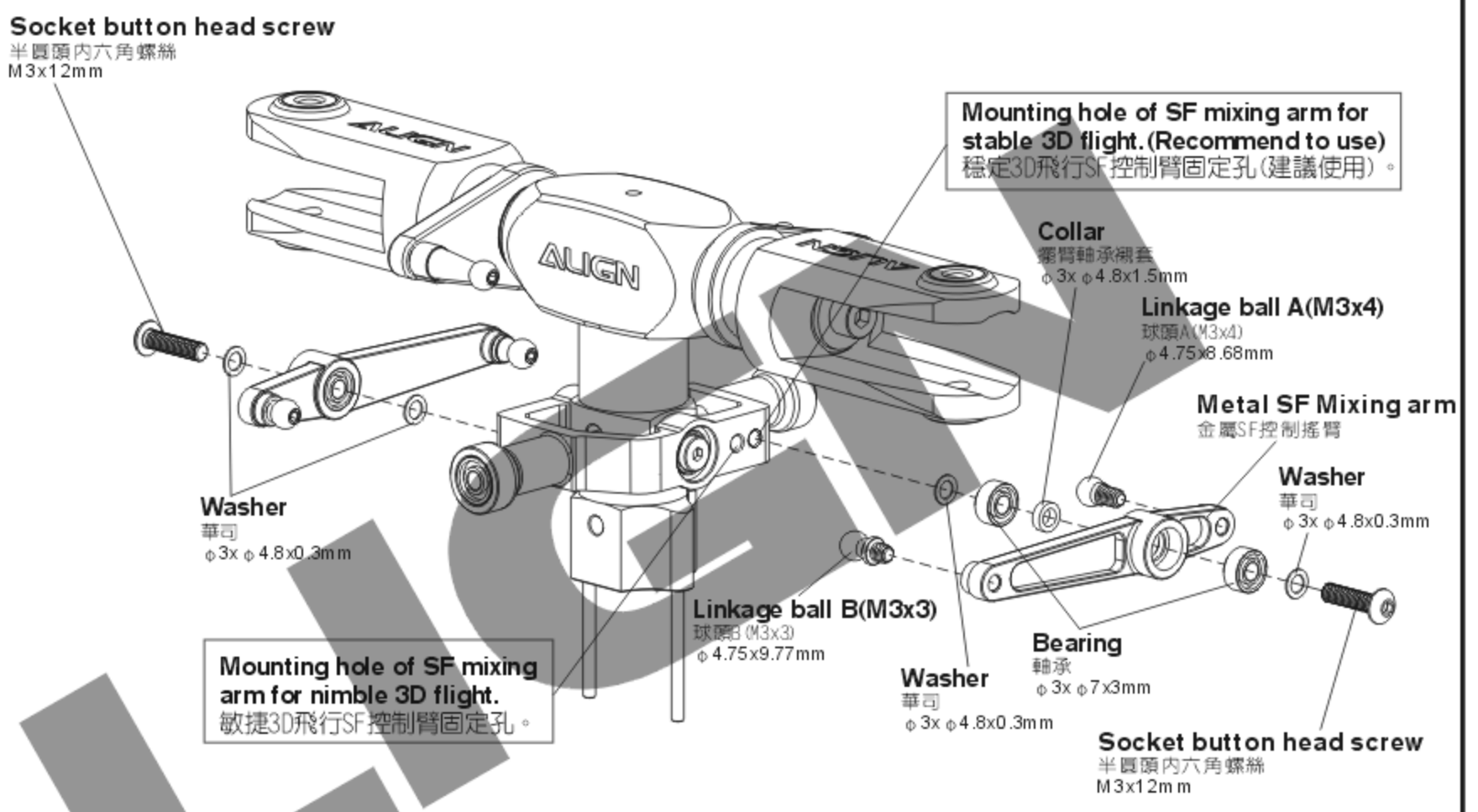

# 600NT3B

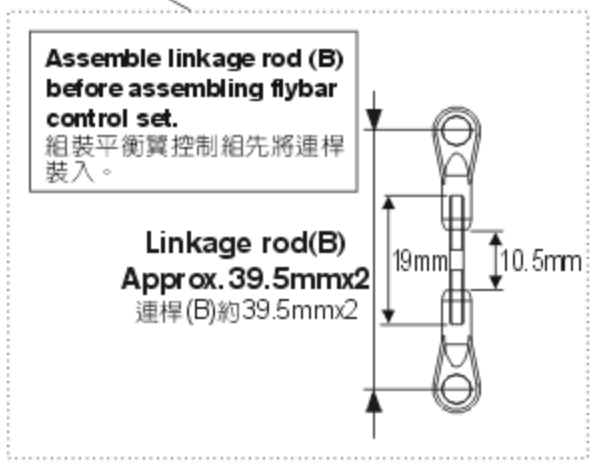
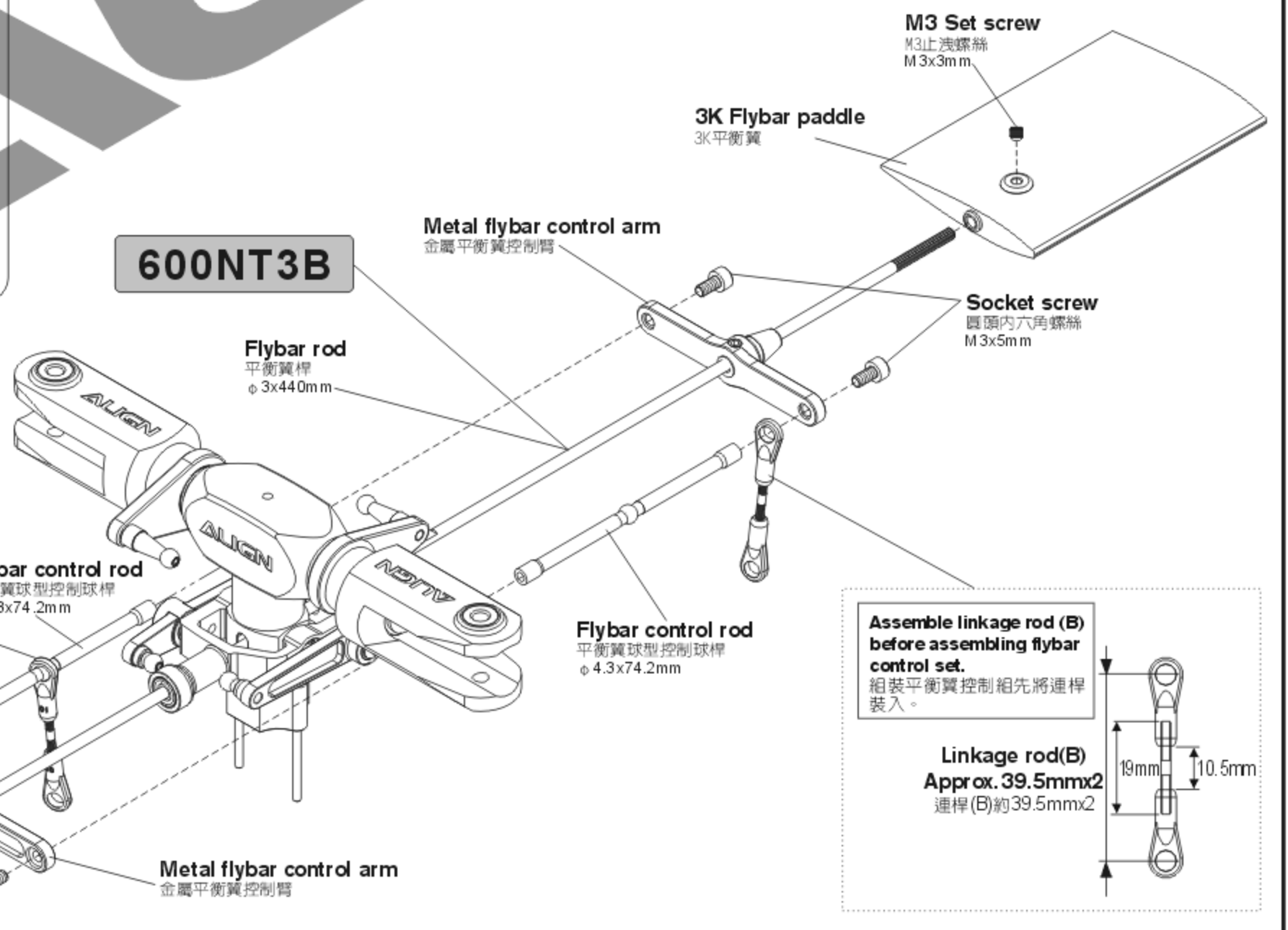

## 600NH8A

Apply a little amount of T43 thread lock when fixing a metal part.  
螺絲鎖附於金屬件請使用適量T43(螺絲膠)

**Linkage ball B(M3x3)**  
球頭B (M3x3) (φ 4.75x9.77mm) x 2

**Socket collar screw**  
圓頭內六角軸套螺絲(M3x22mm) x 1

**M3 Nut**  
M3防鬆螺帽 x 1

## 600NH8

**Bearing**  
軸承(φ 3xφ 7x3mm)x4

**Bearing**  
軸承(φ 2xφ 5x2.3mm) x 4

**Socket screw**  
圓頭內六角螺絲(M2x5mm) x 4

**Socket button head screw**  
半圓頭內六角螺絲(M3x12mm) x 2

**Washer**  
華司(φ 3xφ 4.8x0.3mm) x 2

**Collar**  
擺臂軸承襯套(φ 3xφ 4.8x1.5mm) x 2

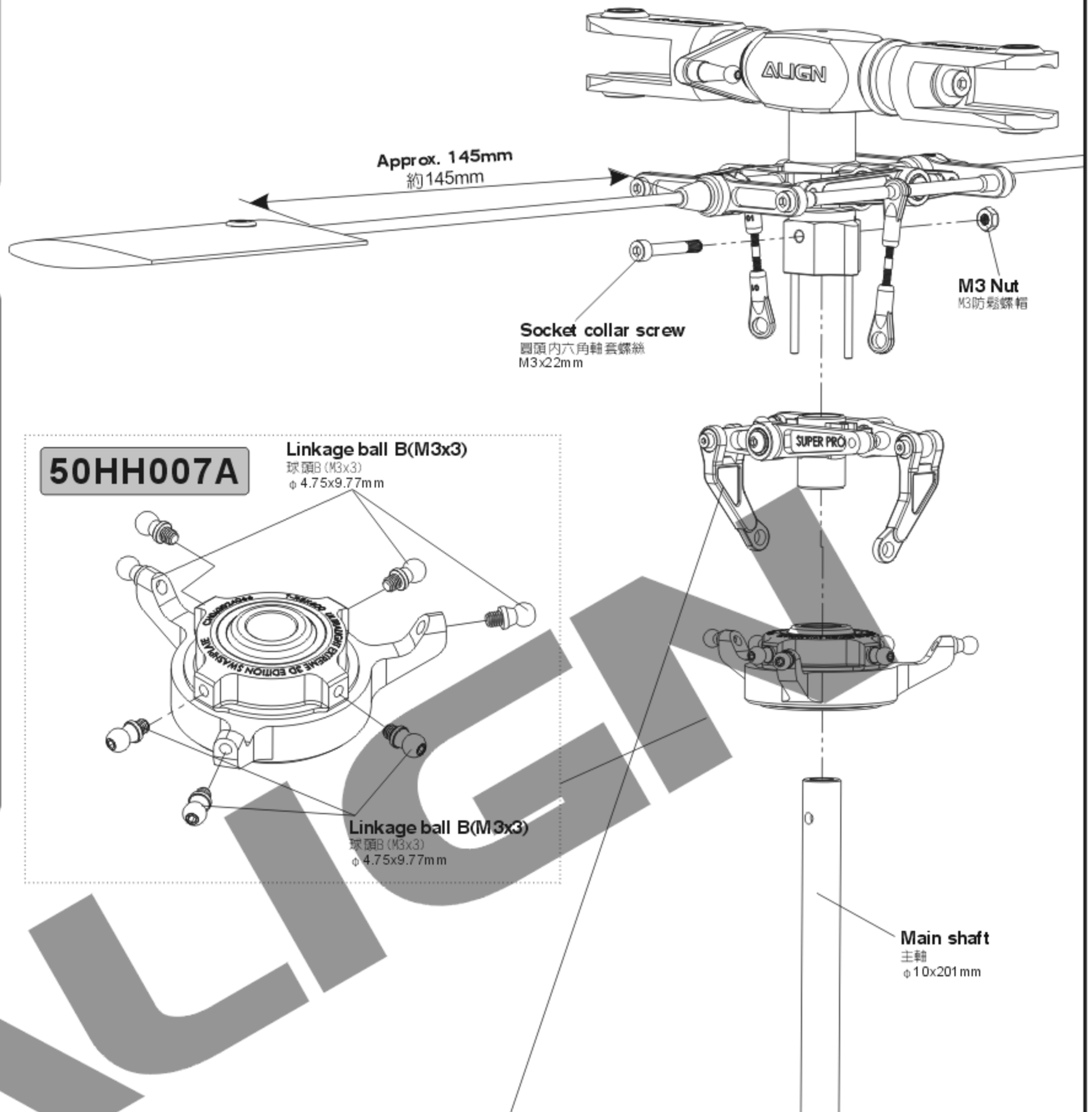

### CAUTION 注意

Already assembled by Factory.  
Before flying, please check if  
the screws are fixed with glue.  
原裝相裝完成品，每一次飛行前請  
先確認螺絲是否已上膠不會鬆動。

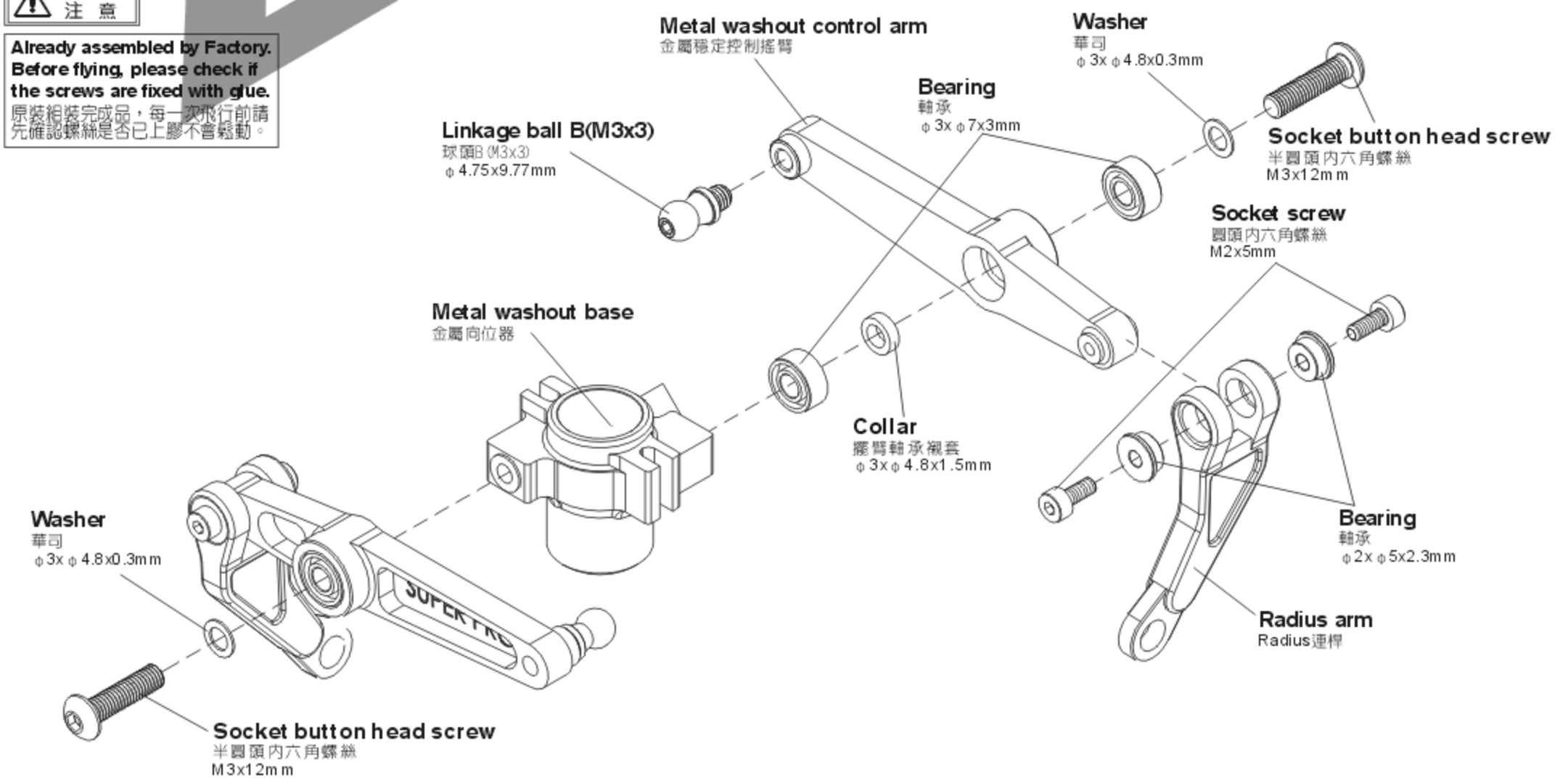



# 600NZ7

**Linkage rod(A)**  
連桿(A) φ2x14mm x 2

**Linkage rod(C)**  
連桿(C) φ2x48mm x 2

# 600NZ7A

**Ball link**  
連桿頭 x 8

# 600NH2C

**Socket screw**  
圓頭內六角螺絲(M3x1.0mm) x 1

Apply a little amount of T43 thread lock when fixing a metal part.  
螺絲鎖附於金屬件請使用適量T43(螺絲膠)

**Socket screw**  
圓頭內六角螺絲  
M3x1.0mm

**Metal head stopper**  
金屬旋翼頭制動器

**Linkage rod(A)**  
Approx. 31mm x 2  
連桿(A)約31mm x 2

**Linkage rod(C)**  
Approx. 66mm x 2  
連桿(C)約66mm x 2

**Linkage rod(B)**  
Approx. 39.5mm x 2  
連桿(B)約39.5mm x 2

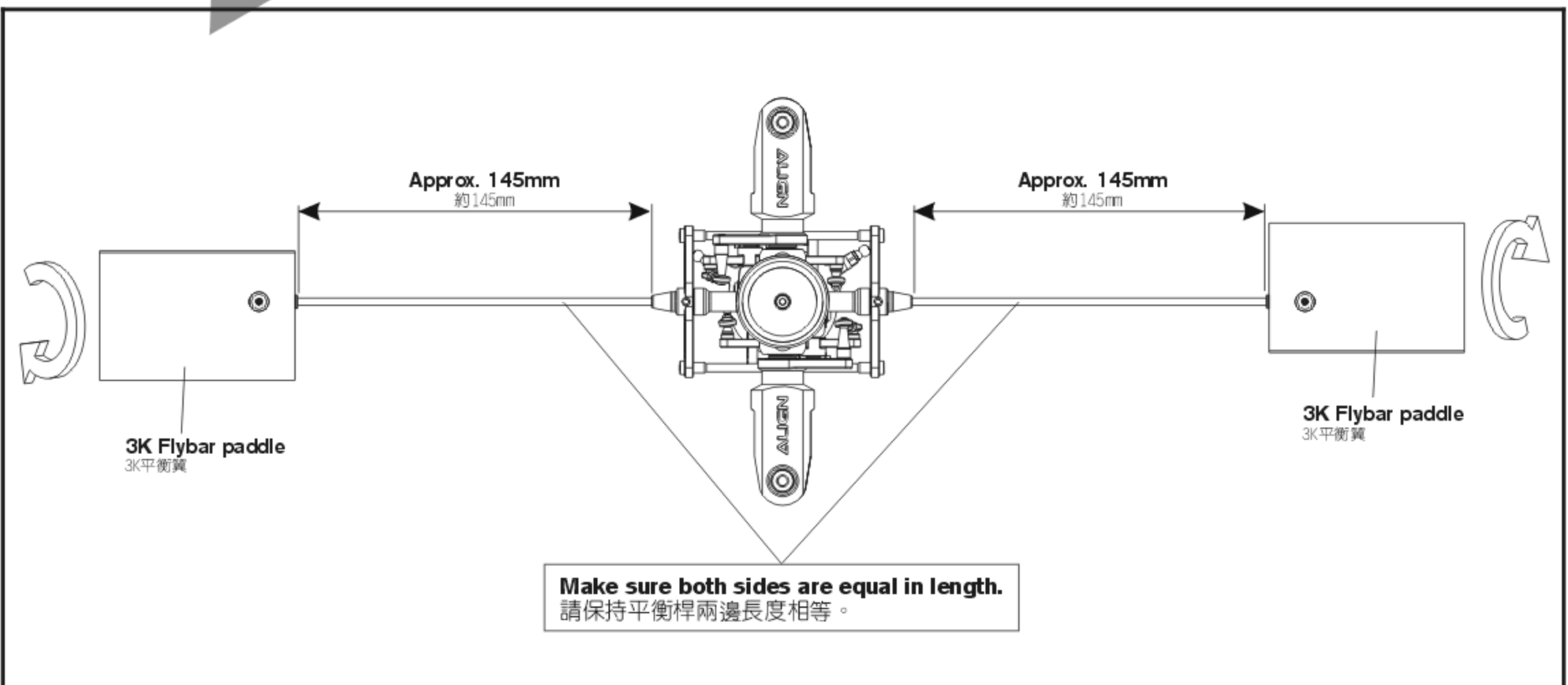
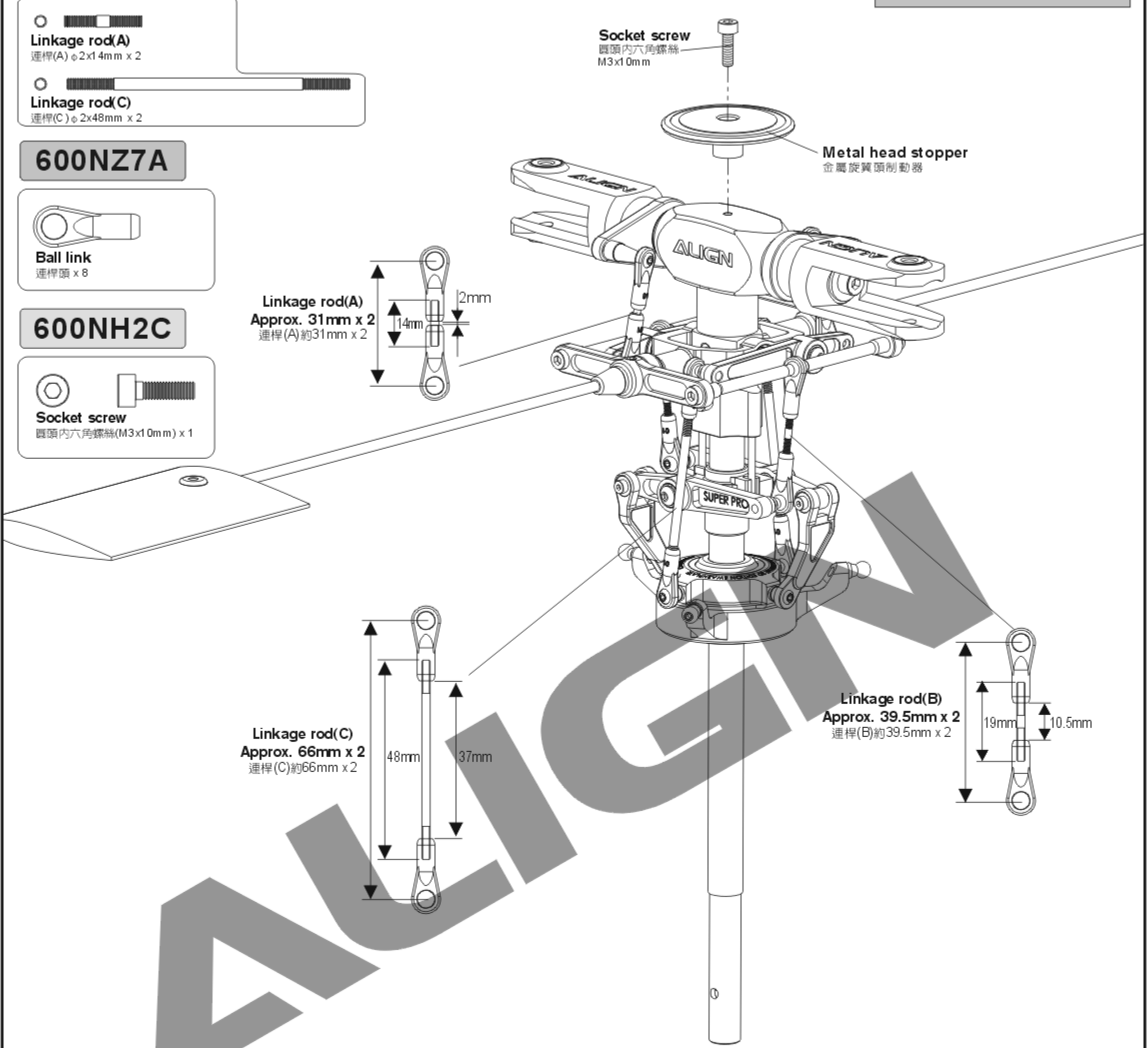

## 600NB3

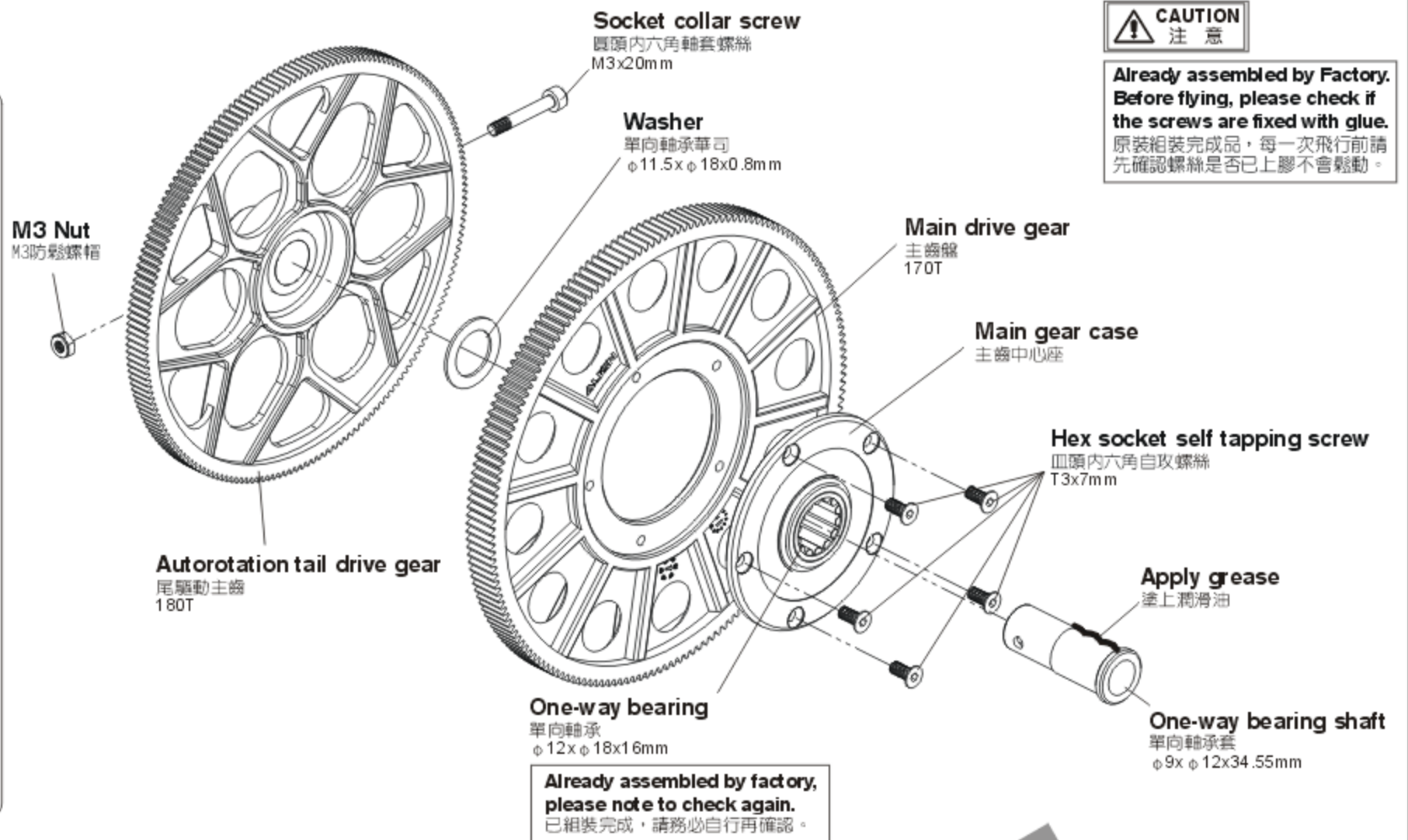
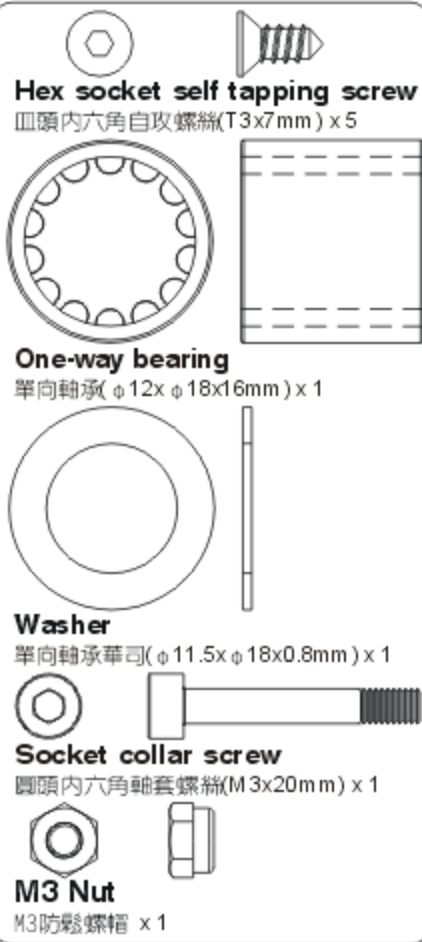

## 600NB4A

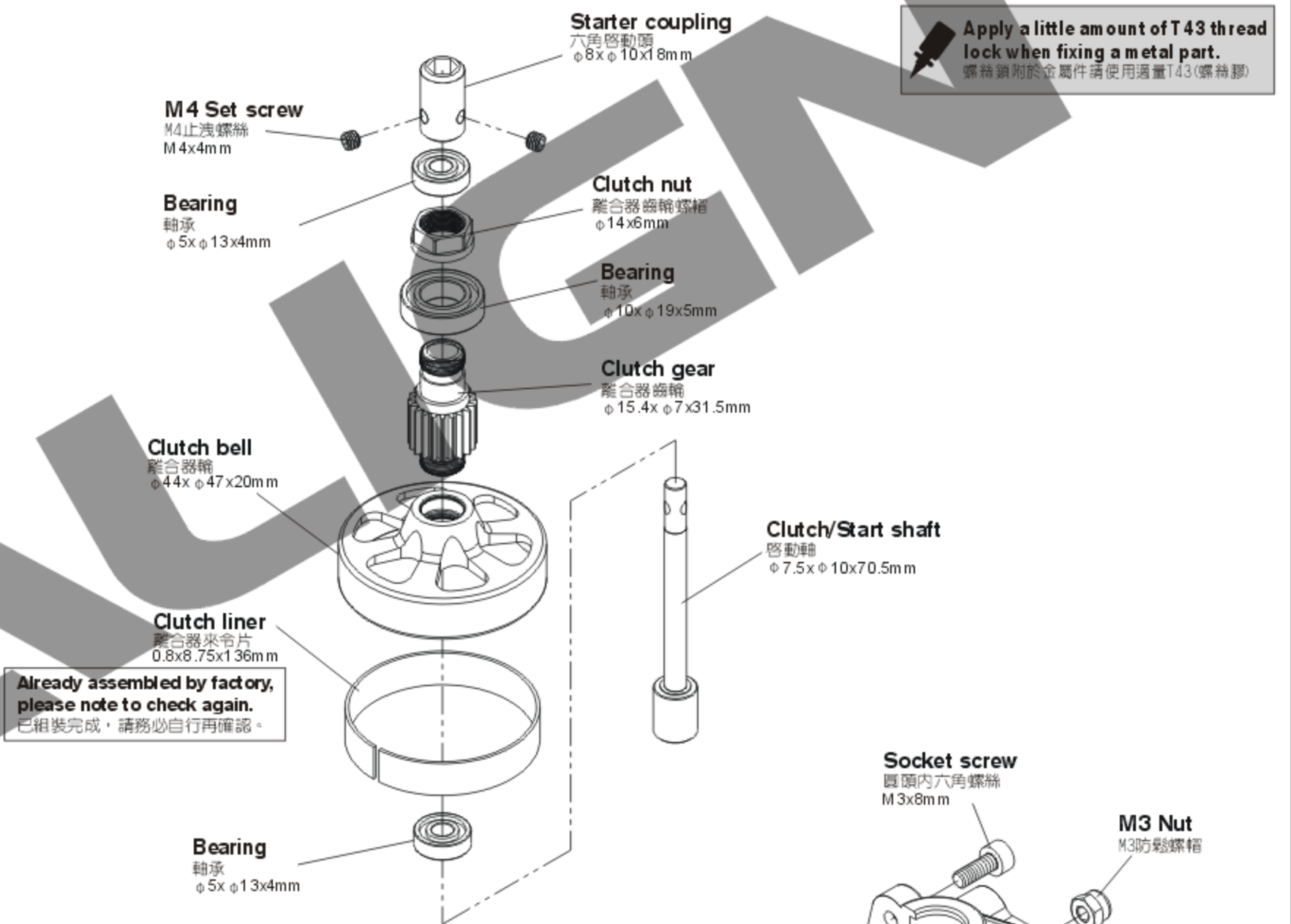
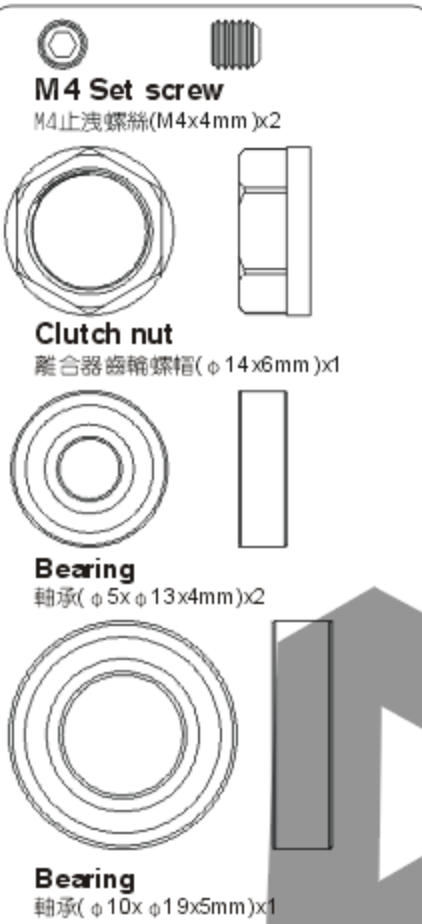

## 600NB4B

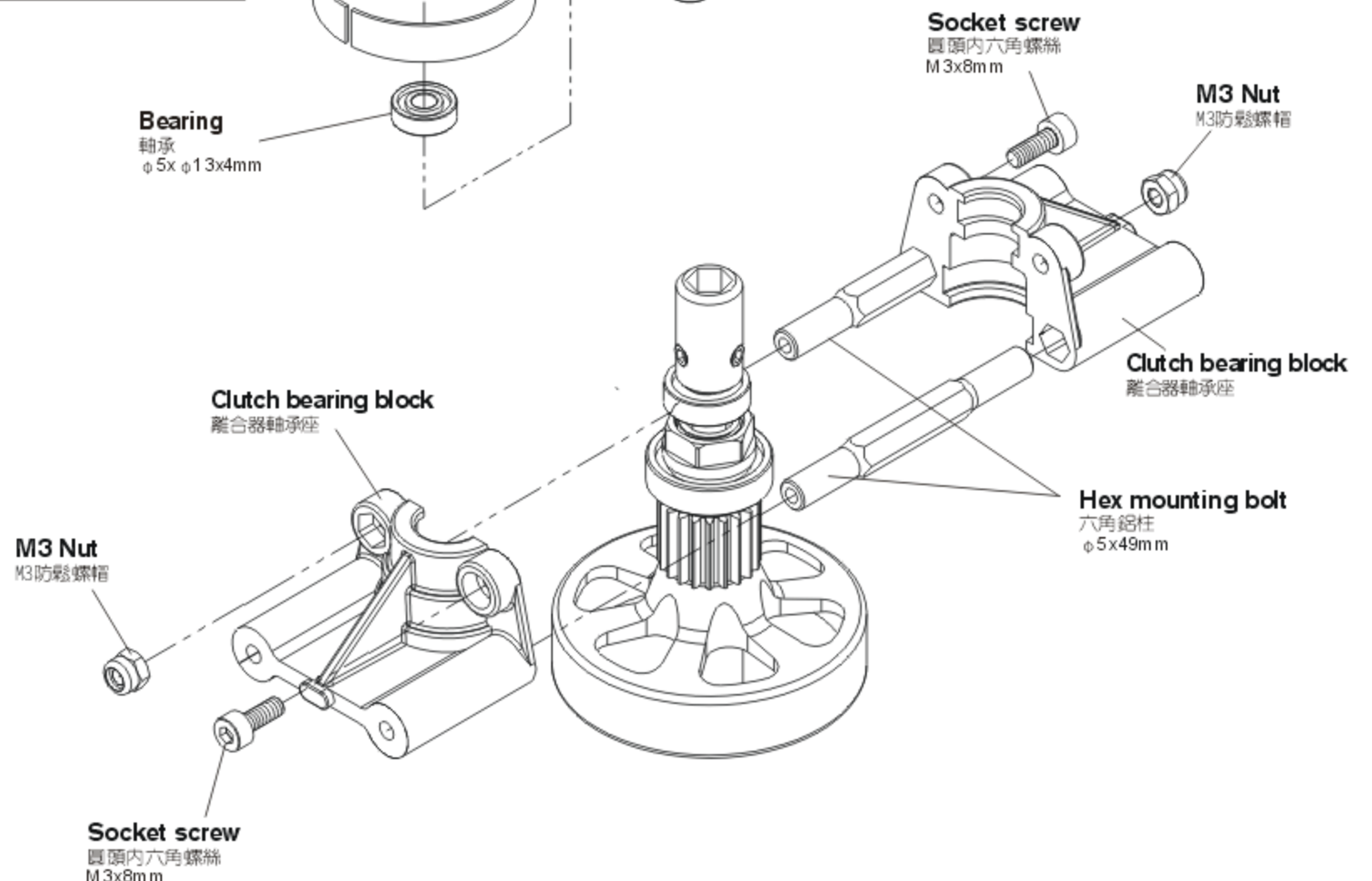
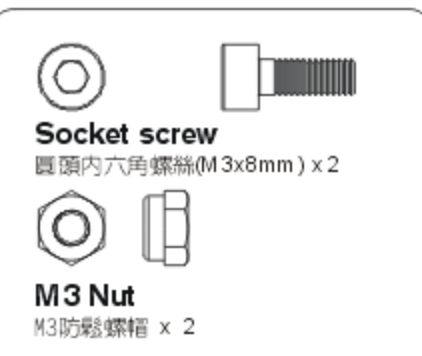

## 600NB1F



**Linkage ball A (M3x4)**  
球頭A (M3x4) (φ4.75x8.68mm) x 1



**Linkage ball B (M3x3)**  
球頭B (M3x3) (φ4.75x9.77mm) x 1



**Washer**  
華司 (φ3xφ4.8x0.3mm) x 2



**Socket button head collar screw**  
半圓頭內六角軸套螺絲 (M3x8mm) x 4



**Socket screw**  
圓頭內六角螺絲 (M3x10mm) x 4



**Socket button head screw**  
半圓頭內六角螺絲 (M3x12mm) x 1



**M3 Specialty washer**  
M3特殊華司 (φ3xφ8x2mm) x 14



**Socket screw**  
圓頭內六角螺絲 (M3x8mm) x 10

## 600NB1G



**Bearing**  
軸承 (φ10xφ19x5mm) x 2



**Bearing**  
軸承 (φ9xφ17x5mm) x 1



**Socket screw**  
圓頭內六角螺絲 (M3x14mm) x 2



**Collar**  
尾控制臂鋁套 (φ3xφ4.4x3mm) x 1



**M3 Set screw**  
M3止洩螺絲 (M3x15mm) x 2



**Socket screw**  
圓頭內六角螺絲 (M2x6mm) x 8



**Socket button head collar screw**  
半圓頭內六角軸套螺絲 (M3x8mm) x 8

## 600NB4B



**Socket button head collar screw**  
半圓頭內六角軸套螺絲 (M3x8mm) x 4

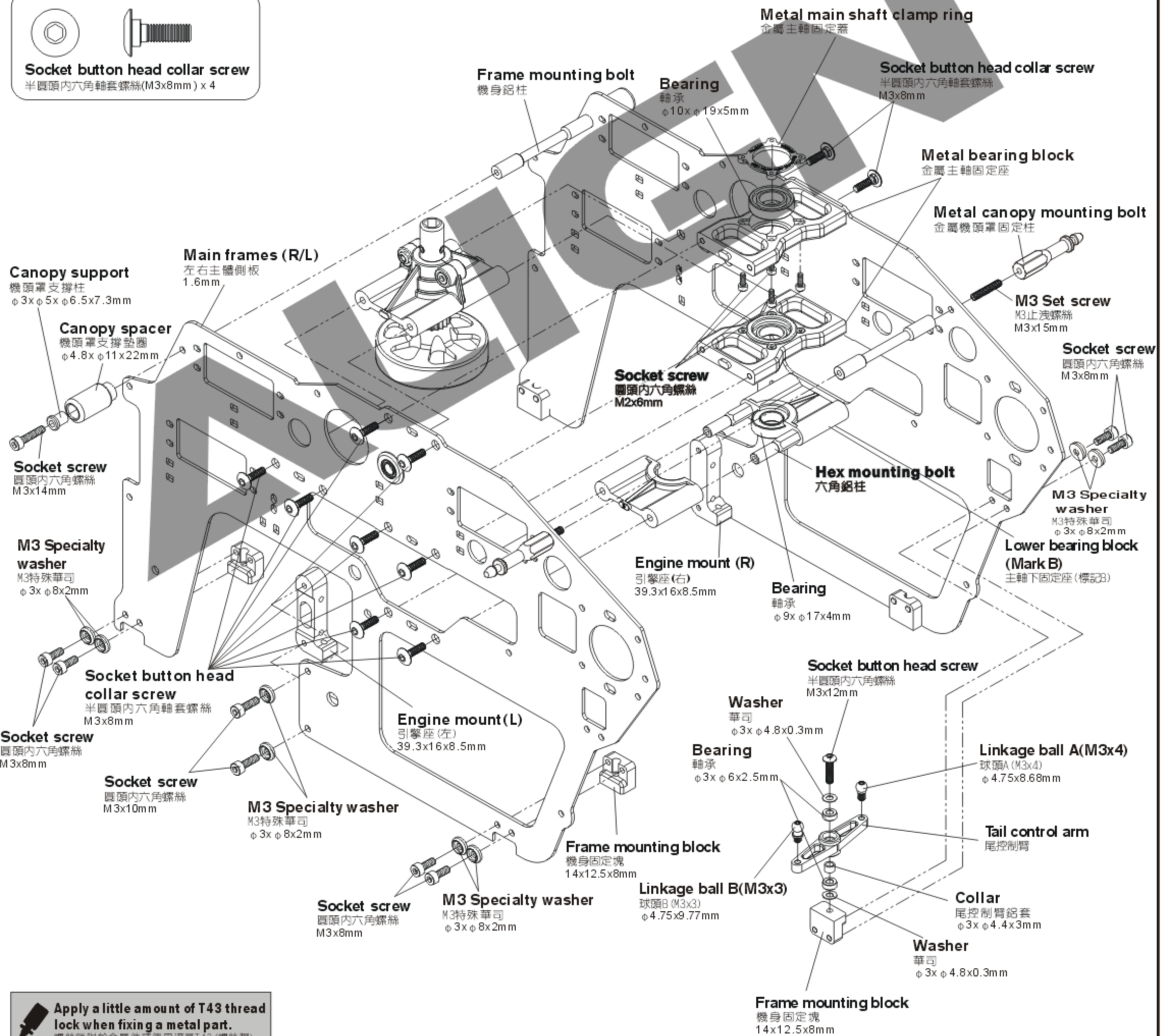

Apply a little amount of T43 thread lock when fixing a metal part.  
螺絲鎖附於金屬件請使用適量T43 (螺絲膠)

**Main frame assembly point:**

First do not fully tighten the screws of main frames and put three bearings through the main shaft to check if the movements are smooth. The bottom bracket must be firmly touched the level table top (glass surface); please keep the smooth movements on main shaft and level bottom bracket, then slowly tighten the screws. This assembly can help for the power and flight performance.

機身側板組立重點：  
側板螺絲先不完全鎖緊，放入主軸貫穿三顆軸承確認上下移動必需滑順，主體底板必須與水平桌面（玻璃平面）踏實緊貼；請保持主軸滑順與底板平行桌面後慢慢鎖緊螺絲。正確側板的組裝對動力與飛行性能有顯著幫助。

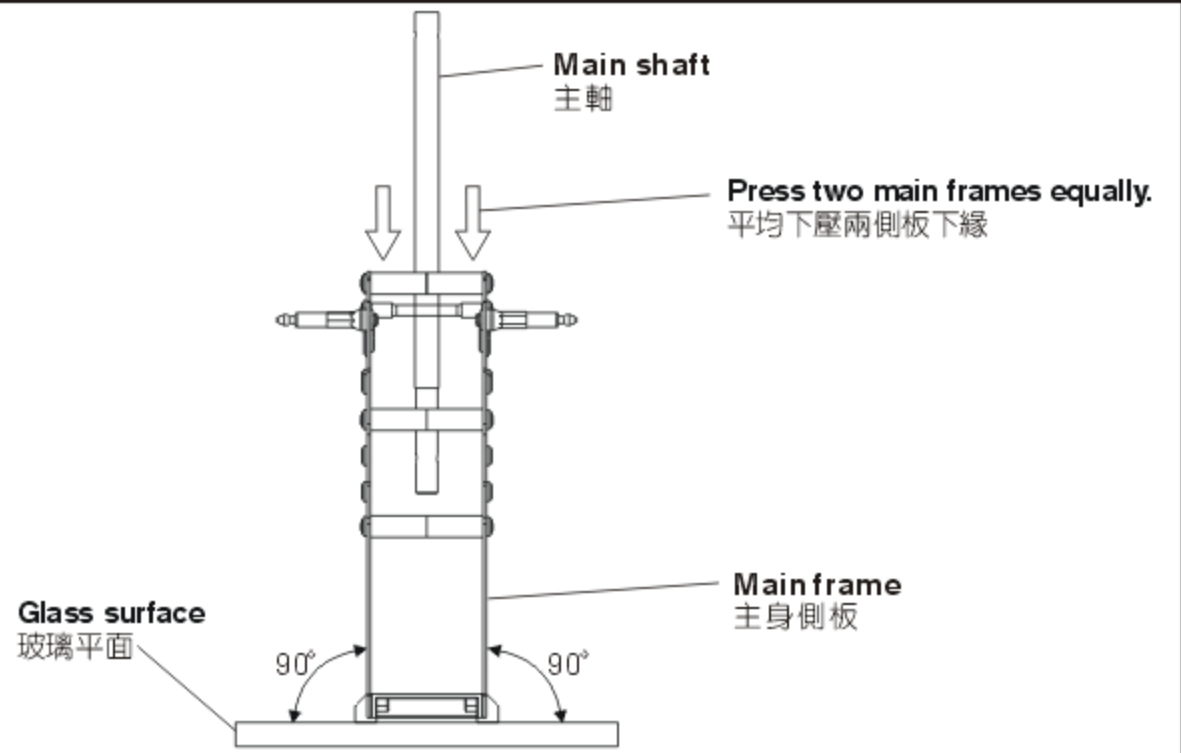

**600NB1F**



**600NG1**

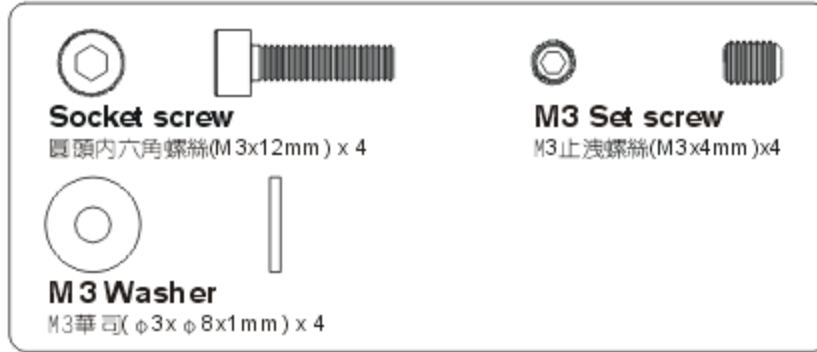

Apply a little amount of T43 thread lock when fixing a metal part.  
螺絲鎖附於金屬件請使用適量T43(螺絲膠)

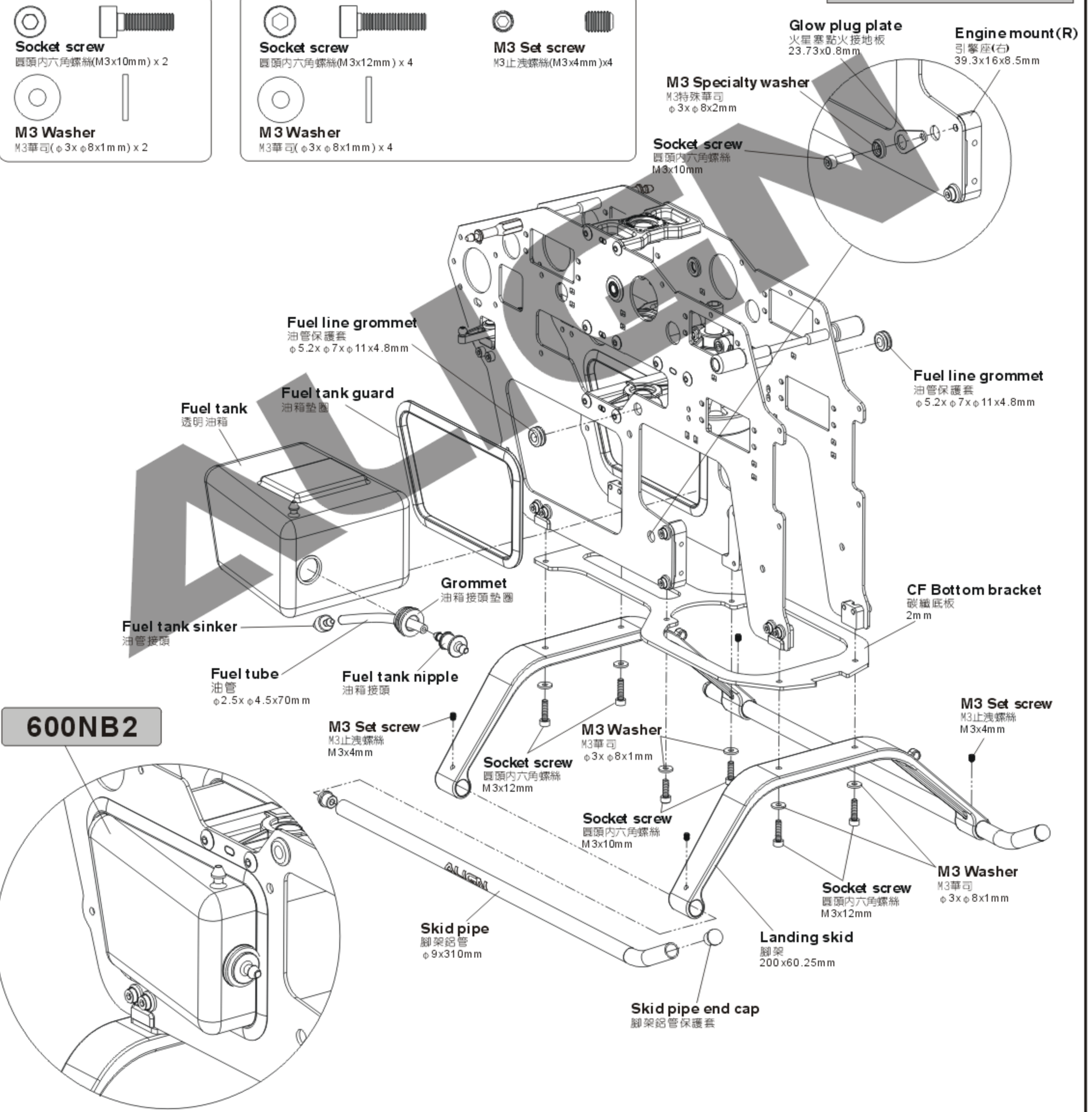

**600NB2**

## 600NB4A



**Socket screw**

圓頭內六角螺絲(M3x12mm) x 2



**Socket head spring screw**

圓頭內六角彈簧螺絲(M4x8mm) x 2



**Socket button head screw**

半圓頭內六角螺絲(M3x5mm) x 2



**Socket button head screw**

半圓頭內六角螺絲(M4x5mm) x 2

## 600NB4B



**M3 Washer**

M3華司(φ3xφ8x1mm) x 4



**M3 Specialty washer**

M3特殊華司(φ3xφ8x2mm) x 4



**Socket screw**

圓頭內六角螺絲(M3x14mm) x 4



**Socket button head self tapping screw**

半圓頭內六角自攻螺絲(T3x10mm) x 4

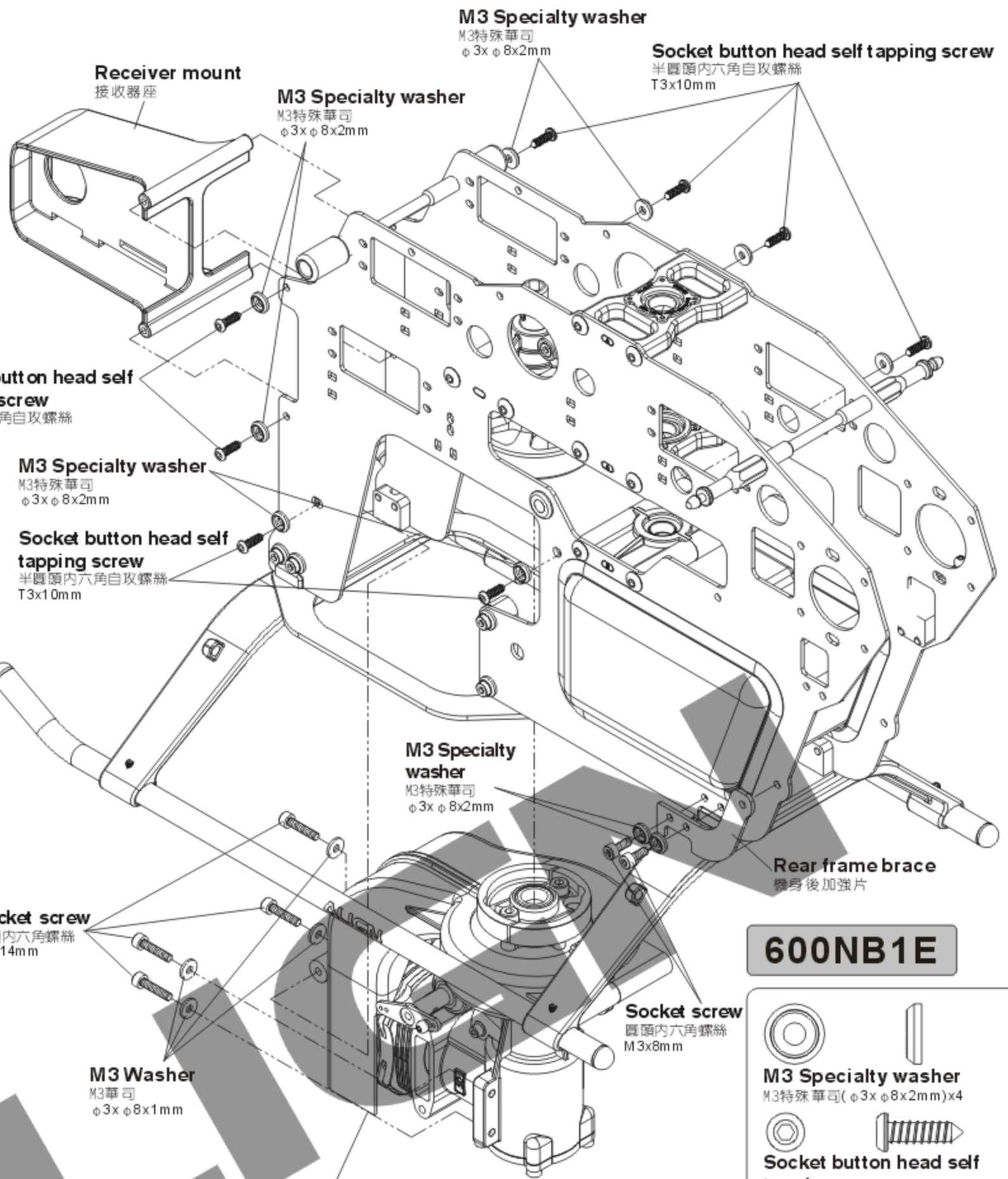

## 600NB1E



**M3 Specialty washer**

M3特殊華司(φ3xφ8x2mm)x4



**Socket button head self tapping screw**

半圓頭內六角自攻螺絲(T3x10mm)x4

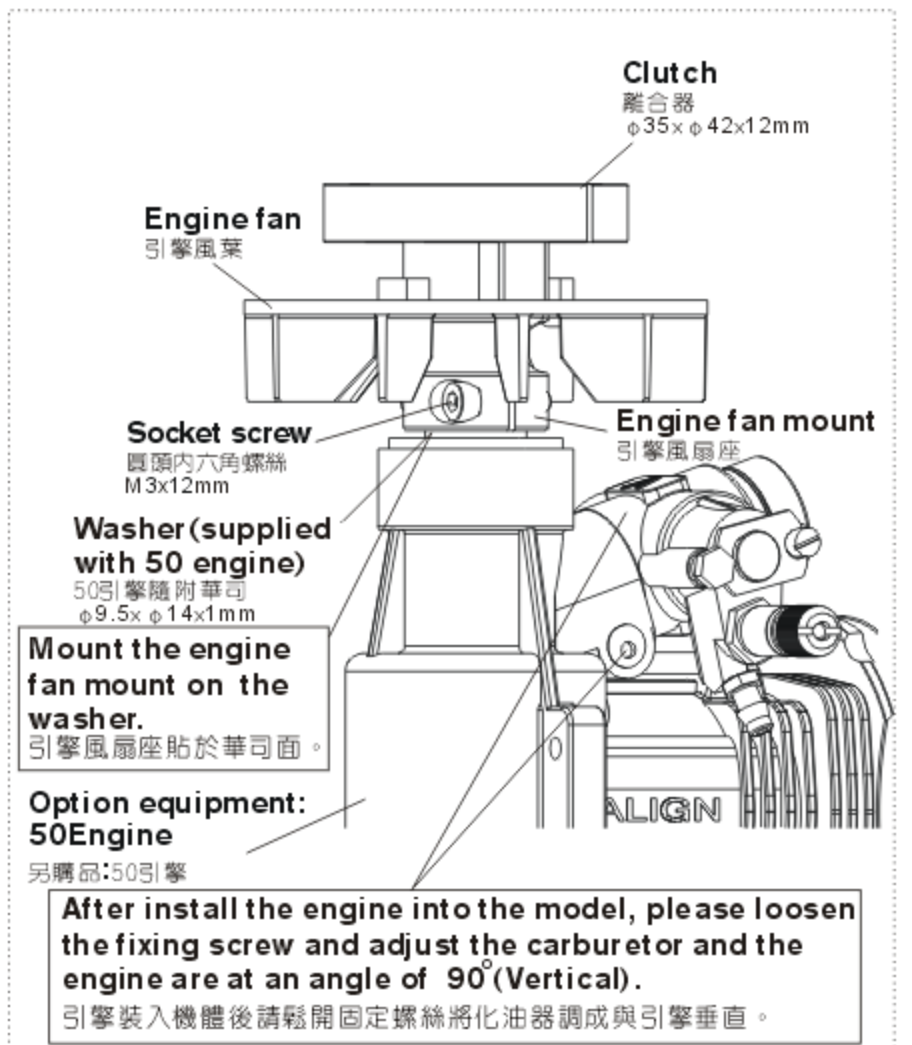
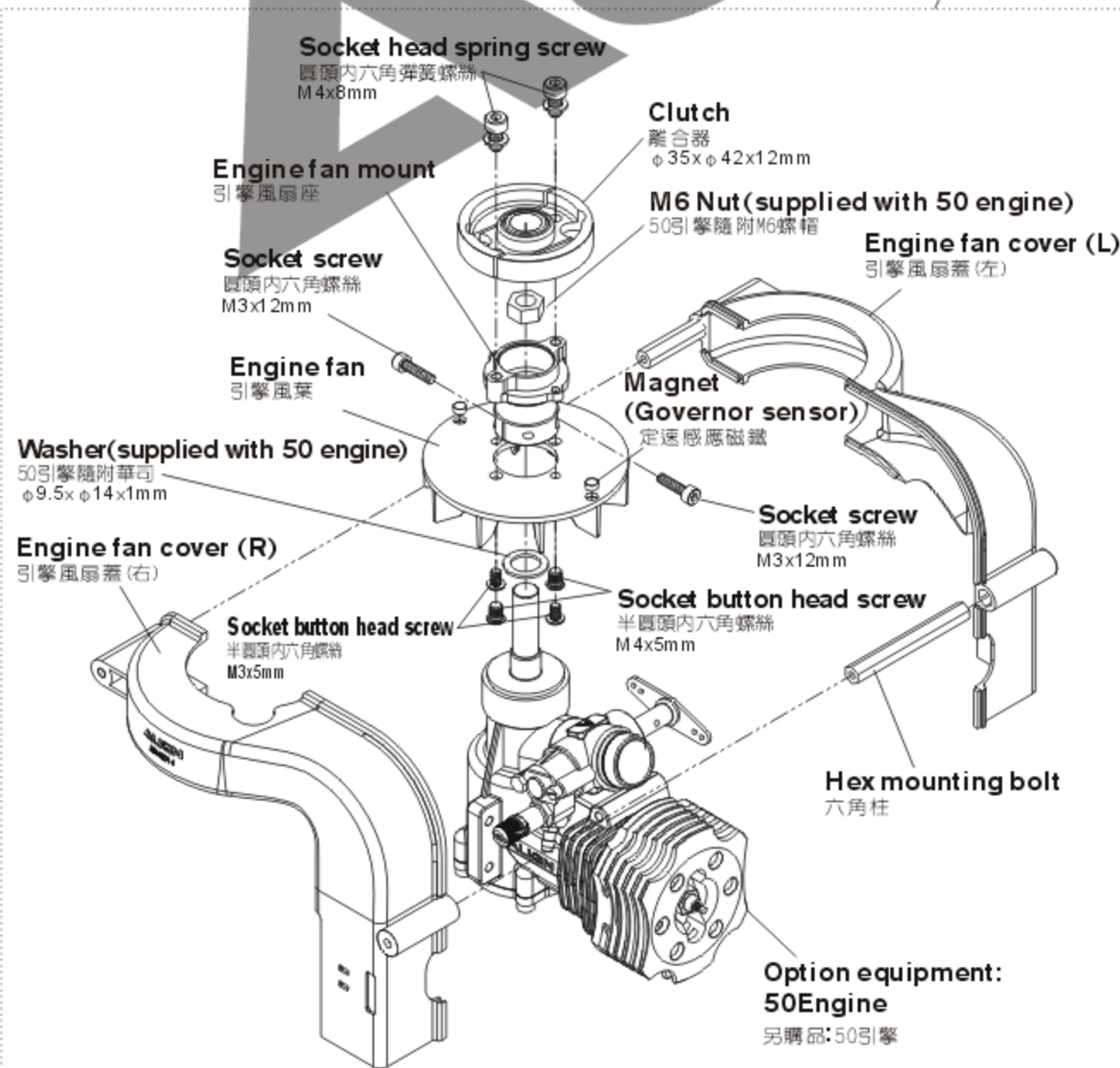

After install the engine into the model, please loosen the fixing screw and adjust the carburetor and the engine are at an angle of 90°(Vertical).

引擎裝入機體後請鬆開固定螺絲將化油器調成與引擎垂直。

Apply a little amount of T43 thread lock when fixing a metal part.  
螺絲鎖附於金屬件請使用適量T43(螺絲膠)

Recommend sanding the marked position as below illustration with a waterproof abrasive paper(#800-1000) to avoid the wires of electric parts to be cut.

建議於下圖色塊標示處，使用#800-1000水砂紙打磨，可防止電子設備電線被割破。

Waterproof abrasive paper  
水砂紙

**Fan cover fixing Tip**  
風扇罩固定要領

Before fixing the engine fan cover, please use a starter to rotate the fan and move the fan cover. This is to make sure no any interference, and then secure the fan cover with a fixing screw.  
鎖緊固定引擎散熱風罩前，請先使用啟動棒轉動風扇，並移動風扇罩，確認在風扇無碰觸風扇罩後才鎖緊風扇罩固定螺絲。

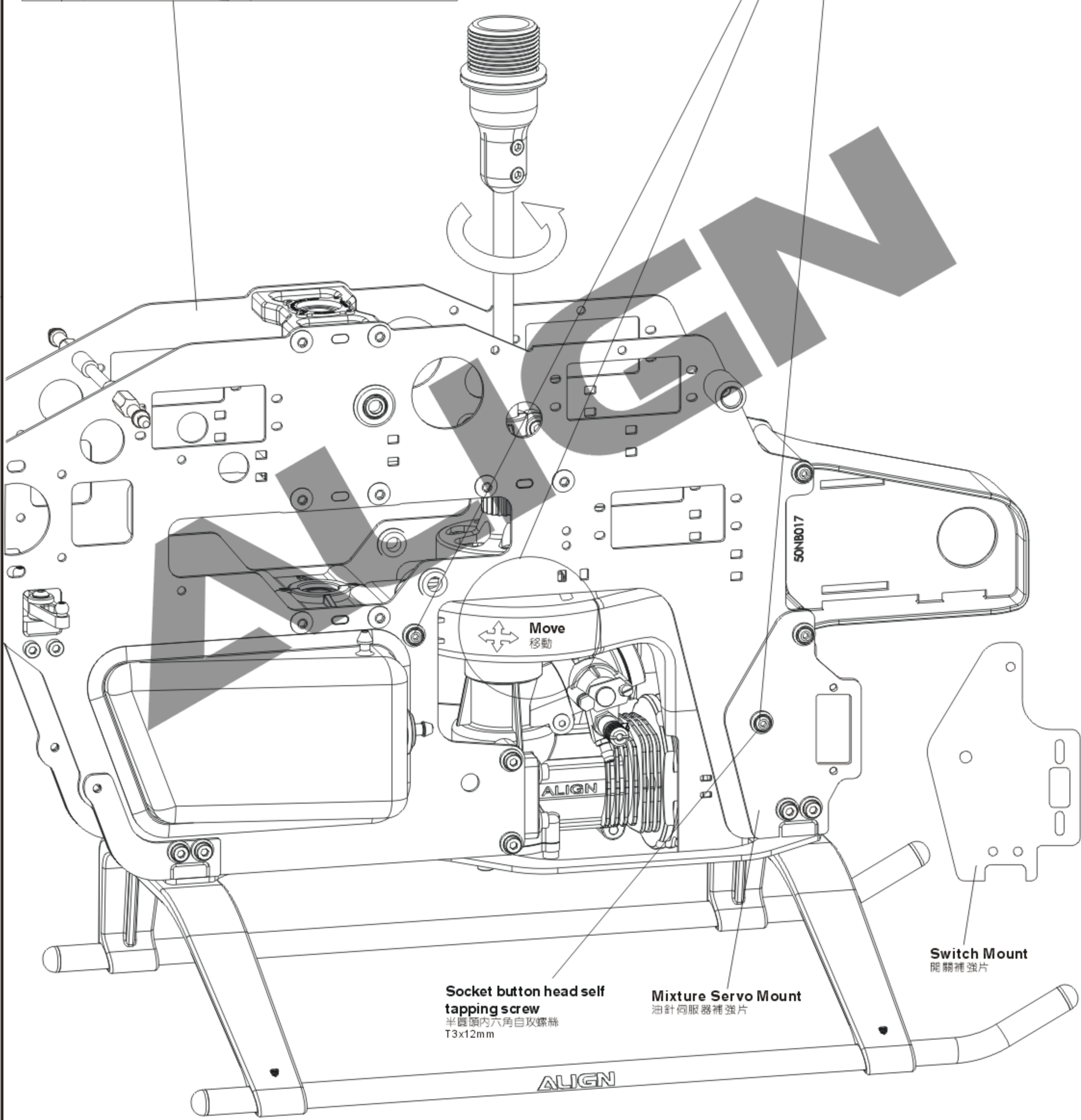

Socket button head self tapping screw  
半圓頭內六角自攻螺絲  
T3x12mm

Mixture Servo Mount  
油針伺服器補強片

Switch Mount  
開關補強片

Apply a little amount of T43 thread lock when fixing a metal part.  
螺絲鎖附於金屬件請使用適量T43(螺絲膠)

## 600NB1H



## 600NB1G

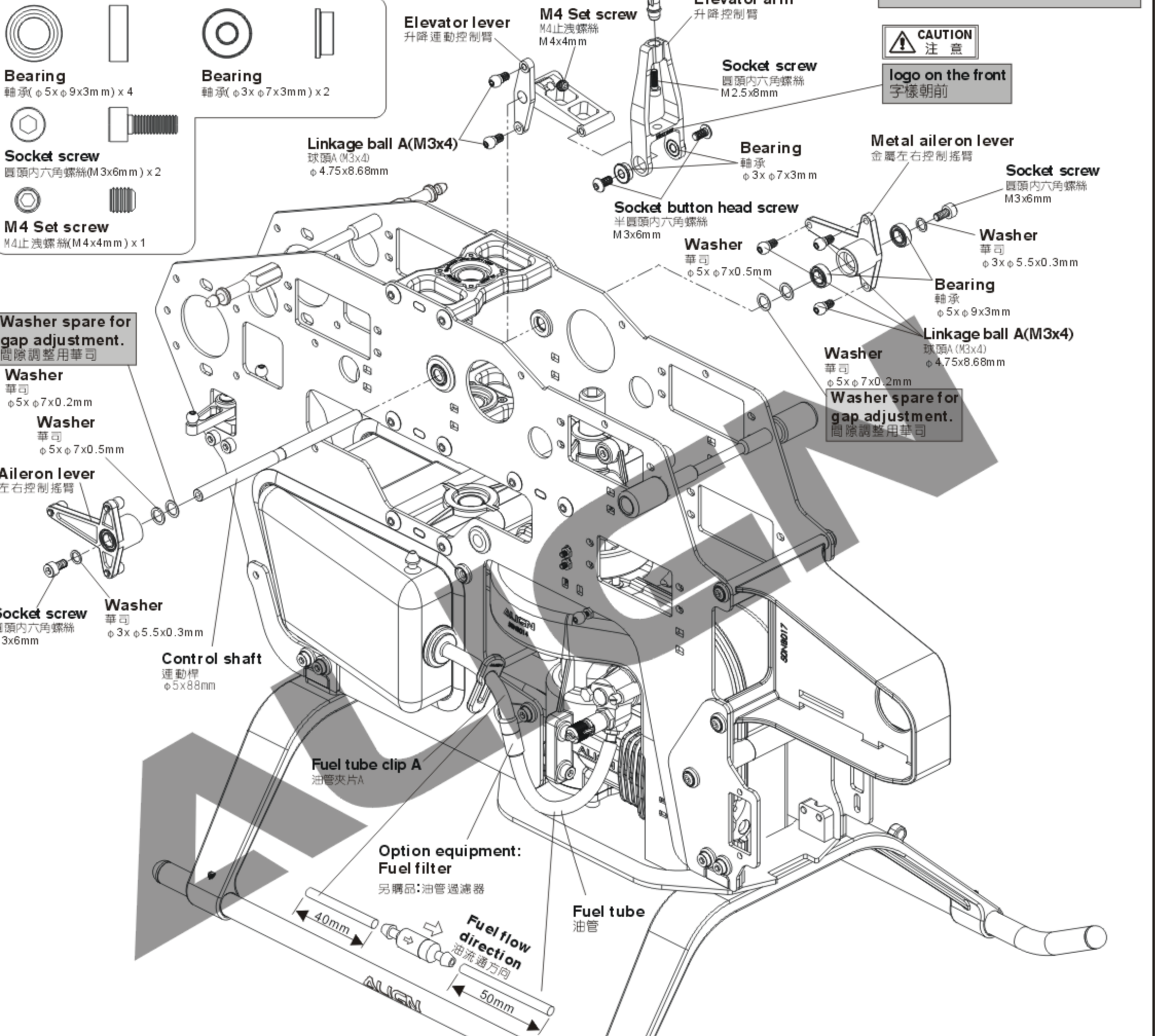

### FUEL TUBE CLIP B ILLUSTRATION 油管夾片B使用說明

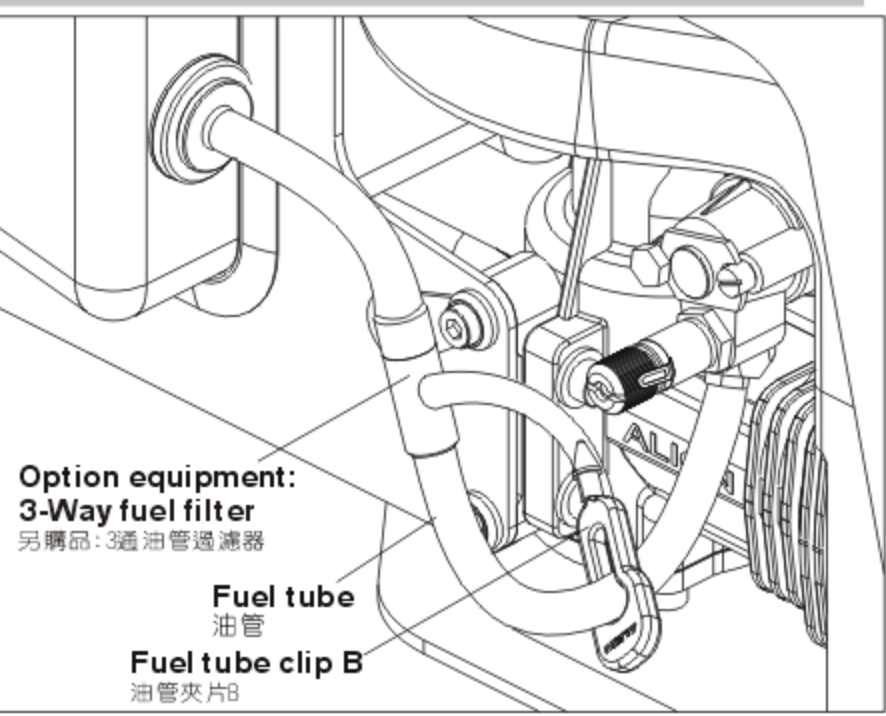

### FUEL TUBE CLIP ILLUSTRATION 油管夾片使用方法

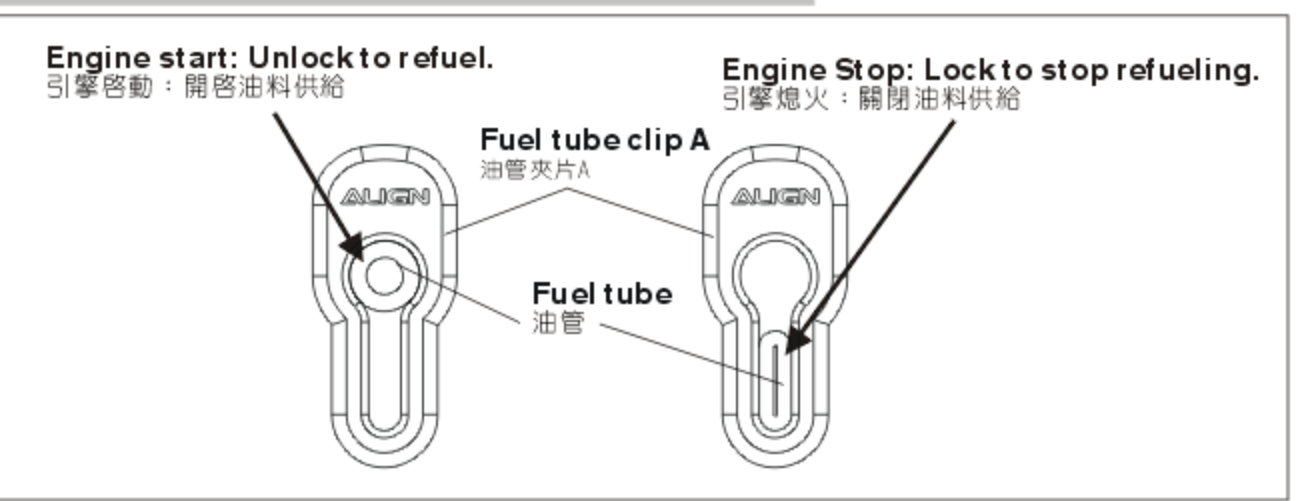

# 600NZ6

- Linkage ball A(M2x3.5)**  
球頭A (M2x3.5) (φ 4.75x8.18mm) x 6
- Socket button head self tapping screw**  
半圓頭內六角自攻螺絲(T3X14mm) x 12
- M2 Nut**  
M2螺帽 x 6

Apply a little amount of T43 thread lock when fixing a metal part.  
螺絲鎖附於金屬件請使用適量T43(螺絲膠)

# 600NZ7A

- Ball link**  
連桿頭 x 2

# 600NZ7

- Linkage rod(C)**  
連桿(C) φ 2x48mm x 1

**DS610 Digital Servo:**

1. Stall torque/輸出扭力: 9.6kg.cm(4.8V)  
12.0kg.cm(6.0V)
2. Motion speed/動作速度: 0.10sec/60° (4.8V)  
0.08sec/60° (6.0V)
3. Dimension/尺寸: 40.3 x 20.1 x 36mm
4. Weight/重量: 52.2g

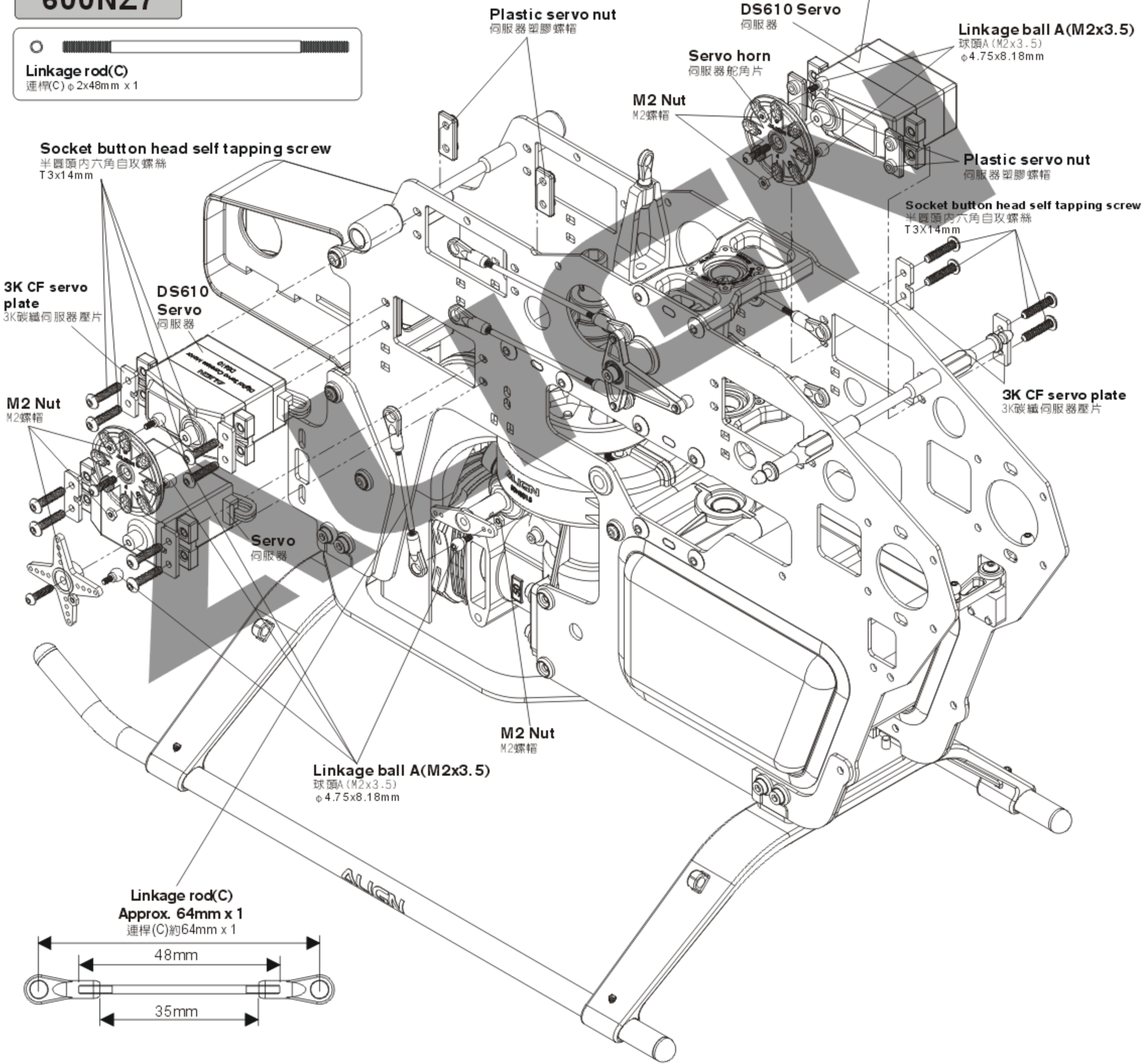



# 600NZ7

**Linkage rod(G)**  
連桿(G)  $\phi 2 \times 61 \text{mm} \times 4$

**Linkage rod(E)**  
連桿(E)  $\phi 2 \times 32 \text{mm} \times 2$

# 600NZ7A

**Ball link**  
連桿頭  $\times 12$

# 600NZ6

**Linkage ball A(M2x3.5)**  
球頭A(M2x3.5) ( $\phi 4.75 \times 8.18 \text{mm}$ )  $\times 3$

**Socket button head self tapping screw**  
半圓頭內六角自攻螺絲(T3X14mm)  $\times 8$

**M2 Nut**  
M2螺帽  $\times 3$

# 600NT3B

**Linkage rod(E)**  
連桿(E) 約  $50 \text{mm} \times 2$

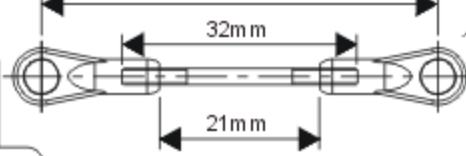

**Tail rudder control rod A**  
尾舵控制連桿A  $216 \text{mm} \times 1$

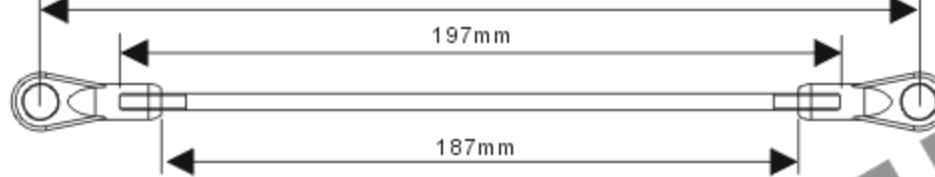

**Linkage rod(G)**  
連桿(G) 約  $80 \text{mm} \times 4$

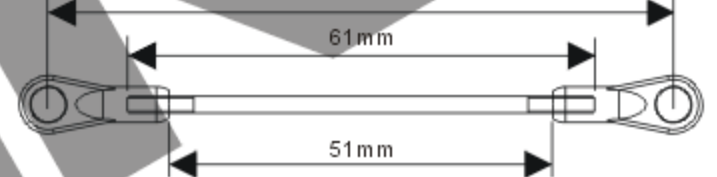

**Keep parallel**  
保持平行

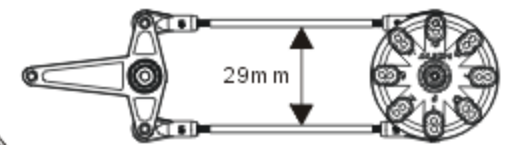

**DS610 Servo**  
DS610伺服器

**Linkage ball A(M2x3.5)**  
球頭A(M2x3.5)  $\phi 4.75 \times 8.18 \text{mm}$

**Nut**  
M2螺帽

**Servo horn**  
伺服器舵角片

**Linkage ball A(M2x3.5)**  
球頭A(M2x3.5)  $\phi 4.75 \times 8.18 \text{mm}$

**Nut**  
M2螺帽

**Tail Servo**  
尾舵伺服器

**Fuel tube cap**  
油管保護套

## DS620 Digital Servo:

1.  $1520 \mu\text{s}$  standard band /  $1520 \mu\text{s}$  寬頻系統
2. Stall torque/輸出扭力:  $8.0 \text{kg} \cdot \text{cm}$  (4.8V)  
 $10.0 \text{kg} \cdot \text{cm}$  (6.0V)
3. Motion speed/動作速度:  $0.09 \text{sec}/60^\circ$  (4.8V)  
 $0.07 \text{sec}/60^\circ$  (6.0V)
4. Dimension/尺寸:  $40.3 \times 20.1 \times 36 \text{mm}$
5. Weight/重量:  $52.2 \text{g}$

Apply a little amount of T43 thread lock when fixing a metal part.  
螺絲鎖附於金屬件請使用適量T43(螺絲膠)

# 600NT1

**Socket button head self tapping screw**  
半圓頭內六角自攻螺絲(T2x8mm) x 2

**Bearing**  
軸承(φ4xφ9x4mm) x 2

**Bearing**  
軸承(φ12xφ18x4mm) x 2

**Bearing**  
軸承(φ12xφ18x4mm) x 2

**CAUTION**  
注意  
Already assembled by Factory.  
Before flying, please check if the screws are fixed with glue.  
原裝相裝完成品，每一次飛行前請先確認螺絲是否已上膠不會鬆動。

**Front drive gear assembly**  
尾傳動導輪軸組

**Front umbrella gear**  
前傘型齒  
φ21.2x33.6mm

**Bearing**  
軸承  
φ12xφ18x4mm

**Socket button head self tapping screw**  
半圓頭內六角自攻螺絲  
T2x8mm

**Tail boom mount (L)**  
尾管固定座(左)

**Bearing**  
軸承  
φ4xφ9x4mm

**Tail boom mount (R)**  
尾管固定座(右)

**Hexagonal bolt**  
六角柱

**Bearing**  
軸承  
φ4xφ9x4mm

**Umbrella gear case (R)**  
傘齒右固定座  
φ15.5xφ19x52.5mm

**Umbrella gear case (L)**  
傘齒左固定座  
φ15.5xφ19x52.5mm

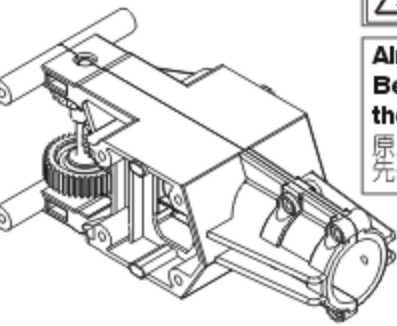

# 600NT2A

**Socket button head screw**  
半圓頭內六角螺絲(M3x6mm) x 6

**Socket screw**  
圓頭內六角螺絲(M3x10mm) x 2

**Socket screw**  
圓頭內六角螺絲(M2x5mm) x 2

**M3 Specialty washer**  
M3特殊華司(φ3xφ8x2mm) x 2

**Bearing**  
軸承(φ5xφ10x5mm) x 2

Apply a little amount of T43 thread lock when fixing a metal part.  
螺絲鎖附於金屬件請使用適量T43(螺絲膠)

**Metal tail unit**  
金屬尾傳固定座  
φ18xφ23.6x53mm

**Metal plate (R)**  
金屬尾傳座右側板  
39.5x25x5mm

**Socket button head screw**  
半圓頭內六角螺絲  
M3x6mm

**Socket screw**  
圓頭內六角螺絲  
M2x5mm

**Control arm mounting bolt**  
軸傳尾控制臂固定座  
15x7x11.6mm

**Socket screw**  
圓頭內六角螺絲  
M3x10mm

**Tail rotor shaft assembly**  
軸傳尾橫軸組

**M3 Specialty washer**  
M3特殊華司  
φ3xφ8x2mm

**Aluminum bolt**  
金屬尾齒箱鋁柱  
φ4.98x24mm

**3K CF Vertical stabilizer**  
3K 碳纖垂直翼

**Socket button head screw**  
半圓頭內六角螺絲  
M3x6mm

**Metal plate (L)**  
金屬尾傳座左側板  
39.5x25x9.3mm

# 600NT2L

**600NT2K**

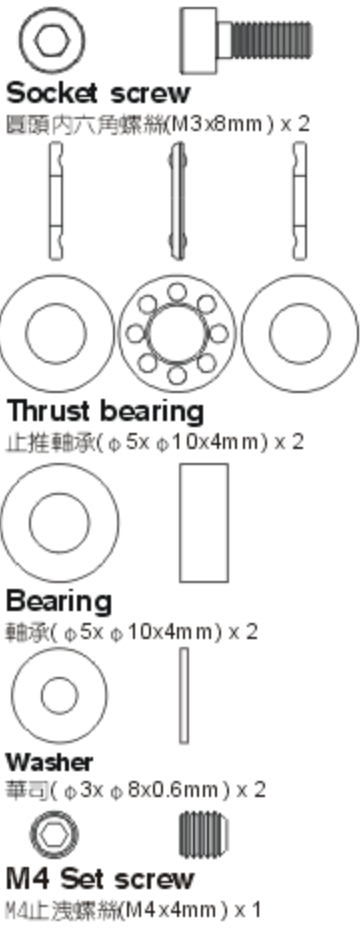

**600NT2C**

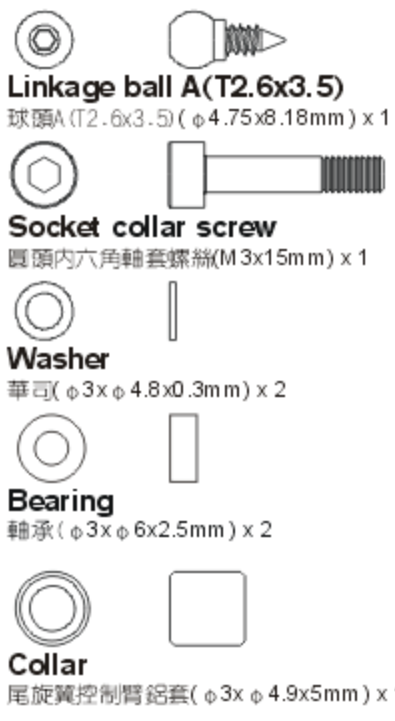

**600NT2I**



**Apply a little amount of T43 thread lock when fixing a metal part.**  
螺絲鎖於金屬件請使用適量T43(螺絲膠)



**Aim tail rotor hub at the concave of tail rotor shaft and fix it, please apply a little glue on the set screw.**  
尾旋翼T型座瞄準尾橫軸的凹刻並鎖上，請確認止洩螺絲上膠。

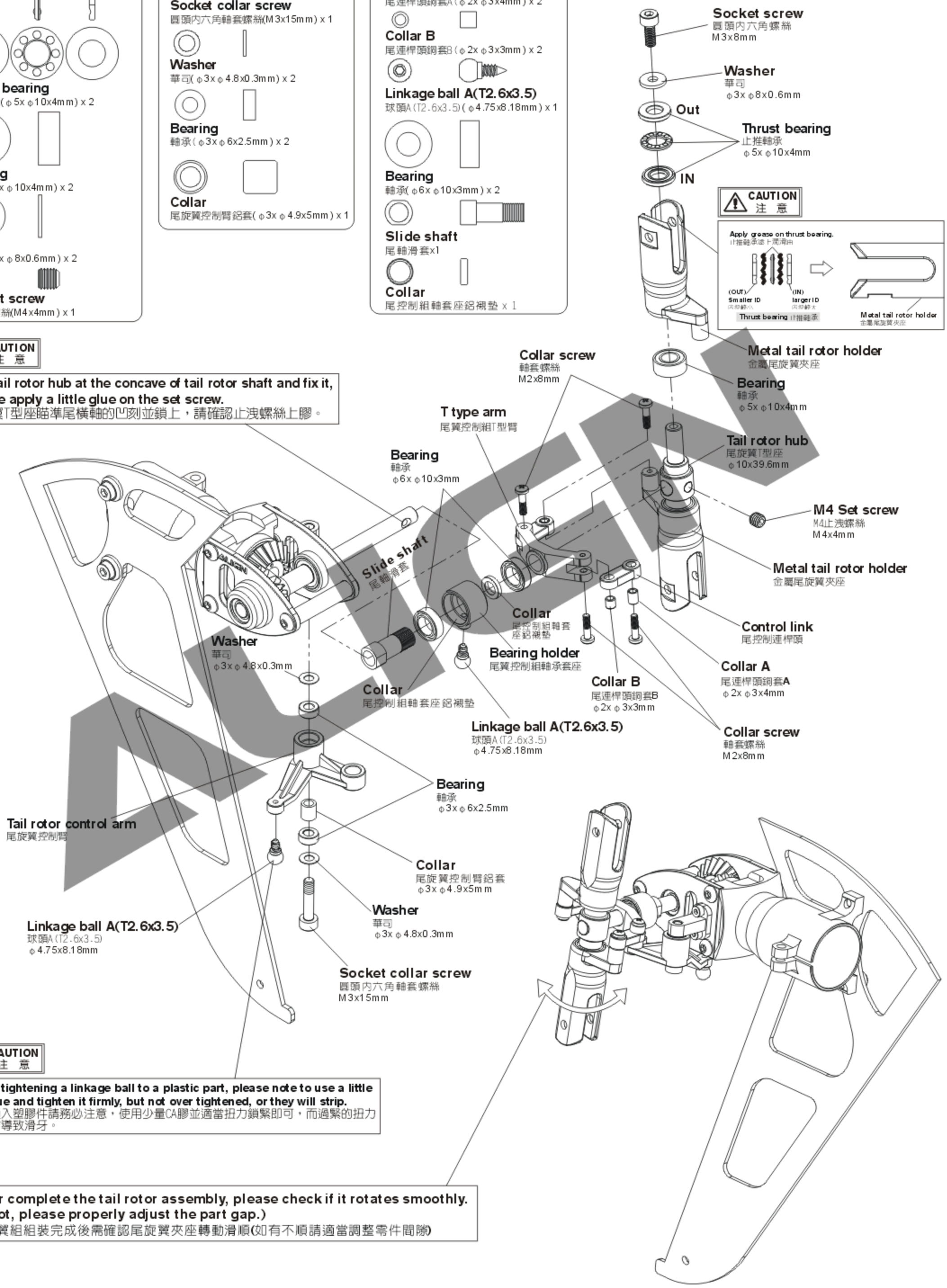

**Apply grease on thrust bearing.**  
止推軸承塗上凡士林油

**CAUTION 注意**

Apply grease on thrust bearing.  
止推軸承塗上凡士林油

(OUT) Smaller ID (內徑較小)  
(IN) larger ID (內徑較大)

**Thrust bearing 止推軸承**

**Metal tail rotor holder 金屬尾旋翼夾座**



**When tightening a linkage ball to a plastic part, please note to use a little CA glue and tighten it firmly, but not over tightened, or they will strip.**  
球頭鎖入塑膠件請務必注意，使用少量CA膠並適當扭力鎖緊即可，而過緊的扭力可能會導致滑牙。

**After complete the tail rotor assembly, please check if it rotates smoothly. (If not, please properly adjust the part gap.)**  
尾旋翼組裝完成後需確認尾旋翼夾座轉動滑順(如有不順請適當調整零件間隙)

Already assembled by factory, please note to check again.  
已組裝完成，請務必自行再確認。

### 600NT2A

**Socket screw**  
圓頭內六角螺絲(M3x8mm) x 1

### 600NT2K

**Socket collar screw**  
圓頭內六角軸套螺絲(M3x16mm) x 2

**M3 Nut**  
M3防鬆螺帽 x 2

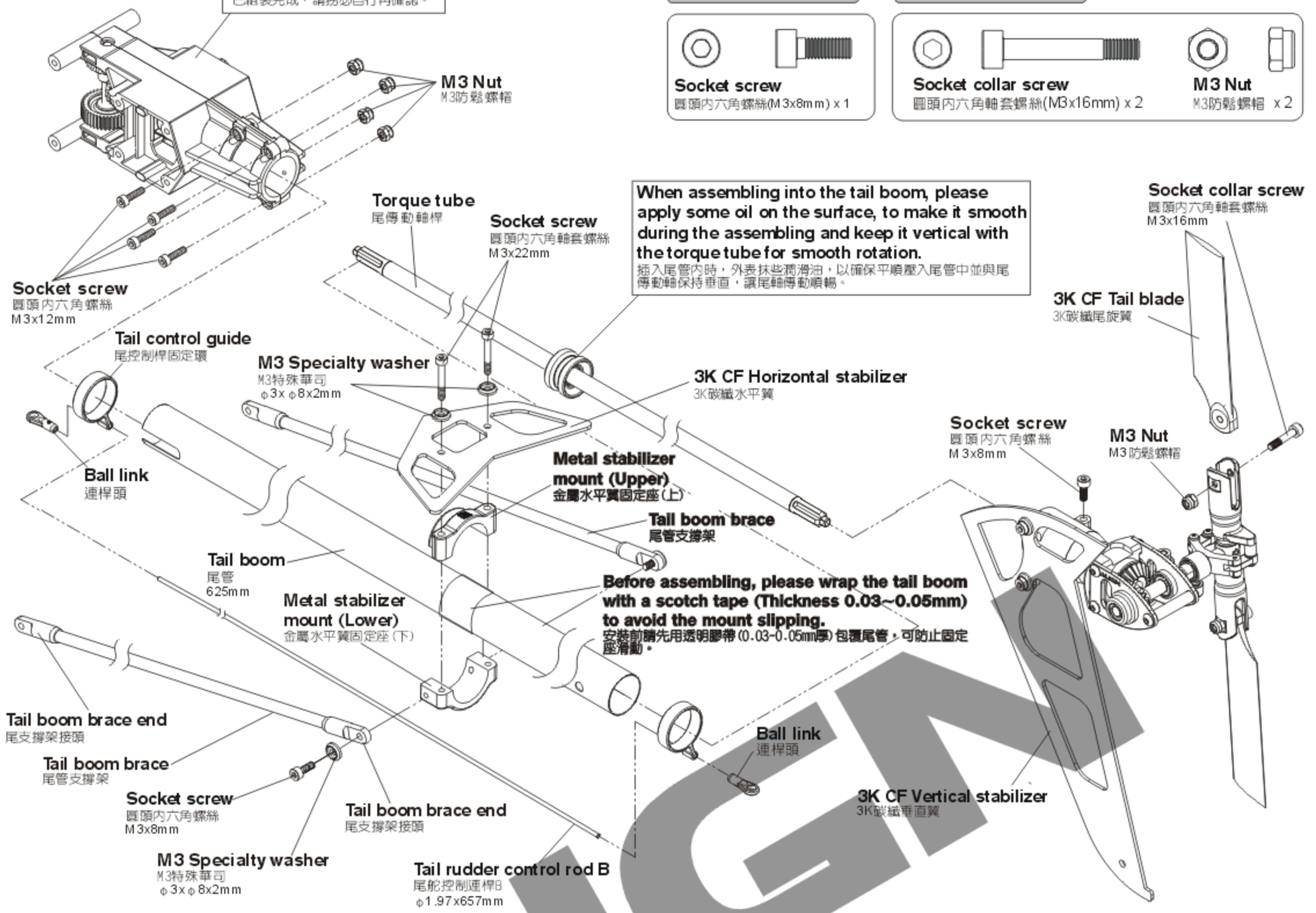

#### Tip to fix the torque tube 傳動軸軸承固定位要領

Please apply some CA glue to fix bearing on the torque tube, avoid CA glue from the dust or may cause the bearing stuck. When assembling into the tail boom, please apply some oil and use the attached PVC packing tube to press the bearing holder of the torque tube into the tail boom horizontally.

請以少量CA將軸承固定於尾傳動軸上，避免CA沾到軸承的防塵蓋而導致軸承卡死，插入尾管內時，尾傳動軸承墊圈外表抹些潤滑油，利用隨附PVC封裝管將尾傳動軸承墊圈平行壓入尾管中不可歪斜。

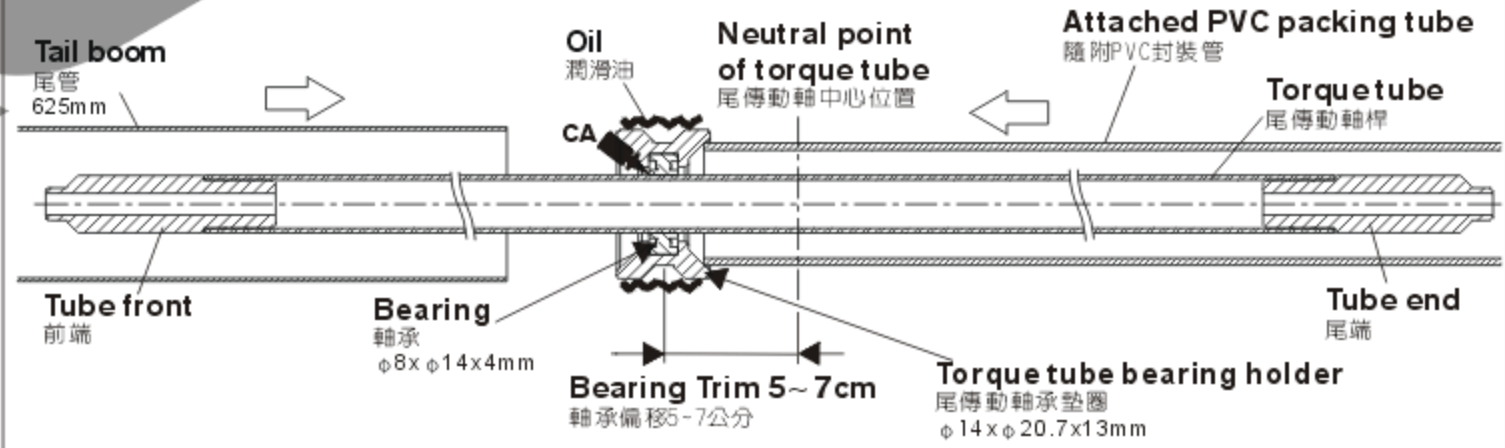

### 600NT1A

**Socket screw**  
圓頭內六角螺絲(M3x12mm) x 4

**M3 Nut**  
M3防鬆螺帽 x 4

### 600NT2LA

**Socket collar screw**  
圓頭內六角軸套螺絲(M3x22mm) x 2

**Socket screw**  
圓頭內六角螺絲(M3x8mm) x 2

**M3 Specialty washer**  
M3特殊華司  $\phi 3 \times \phi 8 \times 2\text{mm}$  x 4

Apply a little amount of T43 thread lock when fixing a metal part.  
螺絲鎖附於金屬件請使用適量T43(螺絲膠)

## 600NB1D



**Socket screw**  
圓頭內六角螺絲(M3x12mm) x 2

## 600NB1E



**Socket button head self tapping screw**  
半圓頭內六角自攻螺絲(T3x8mm) x 2

## 600NB1F



**M3 Specialty washer**  
M3特殊華司(φ3xφ8x2mm) x 2

**Socket button head self tapping screw**  
半圓頭內六角自攻螺絲  
T3x8mm

### High/Low throttle speed setting

油門高/低速控制設定

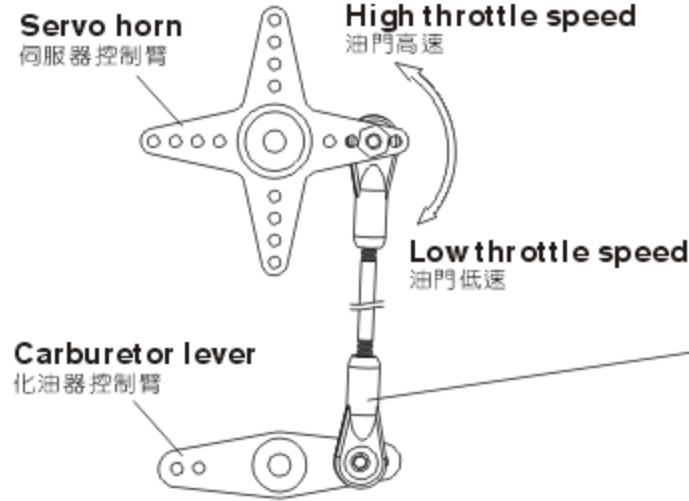

**Linkage rod(C)**  
Approx. 64mm  
連桿(C)約64mm

48mm 35mm

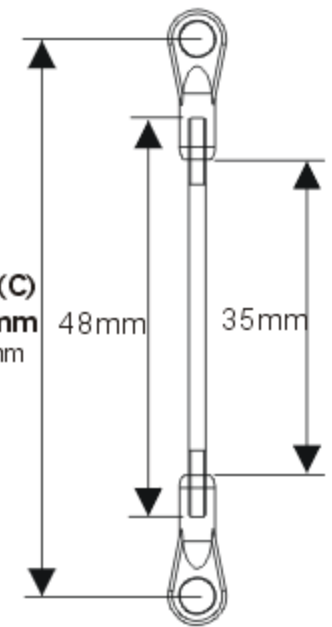

**Gyro Mount**  
陀螺儀固定座

Please assemble the G linkage rods inside the servo horns to avoid any interference caused by the canopy.  
G連桿請裝於伺服器內側確保動作時不碰觸機頭罩

**Socket button head self tapping screw**  
半圓頭內六角自攻螺絲  
T3x12mm

**M3 Specialty washer**  
M3特殊華司  
φ3xφ8x2mm

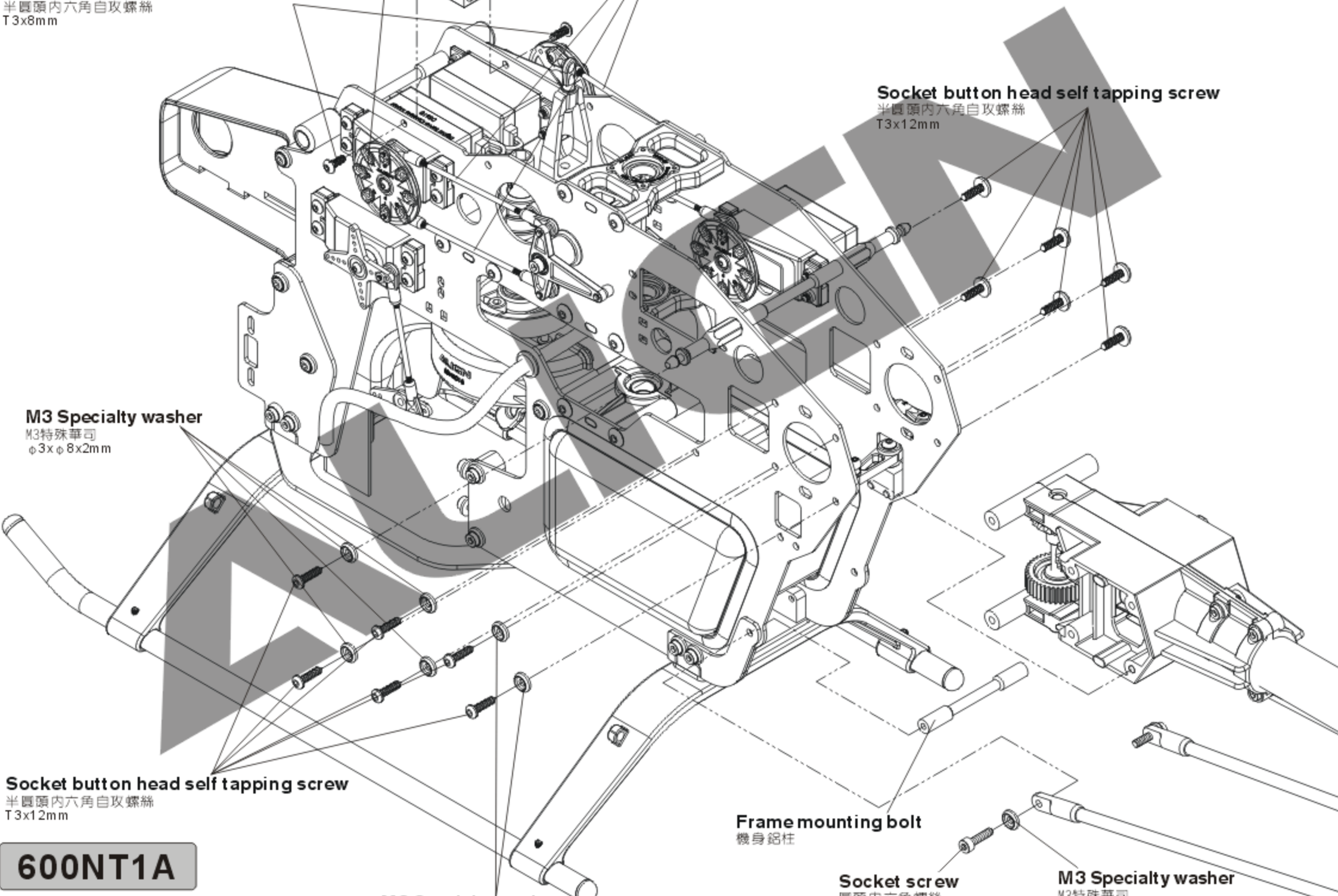

**Socket button head self tapping screw**  
半圓頭內六角自攻螺絲  
T3x12mm

**Frame mounting bolt**  
機身鋁柱

**Socket screw**  
圓頭內六角螺絲  
M3x12mm

**M3 Specialty washer**  
M3特殊華司  
φ3xφ8x2mm

## 600NT1A



**Socket button head self tapping screw**  
半圓頭內六角自攻螺絲(T3x12mm) x 12



**M3 Specialty washer**  
M3特殊華司(φ3xφ8x2mm) x 12



**Socket button head screw**  
半圓頭內六角螺絲(M3x5mm) x 1

Apply a little amount of T43 thread lock when fixing a metal part.  
螺絲鎖附於金屬件請使用適量T43(螺絲膠)

**CAUTION**  
注意

When tightening a screw to a plastic part, please tighten it firmly, but not over tightened, or they will strip.  
螺絲鎖入塑膠件請務必注意，適當扭力鎖緊即可，而過緊的扭力可能會導致滑牙。

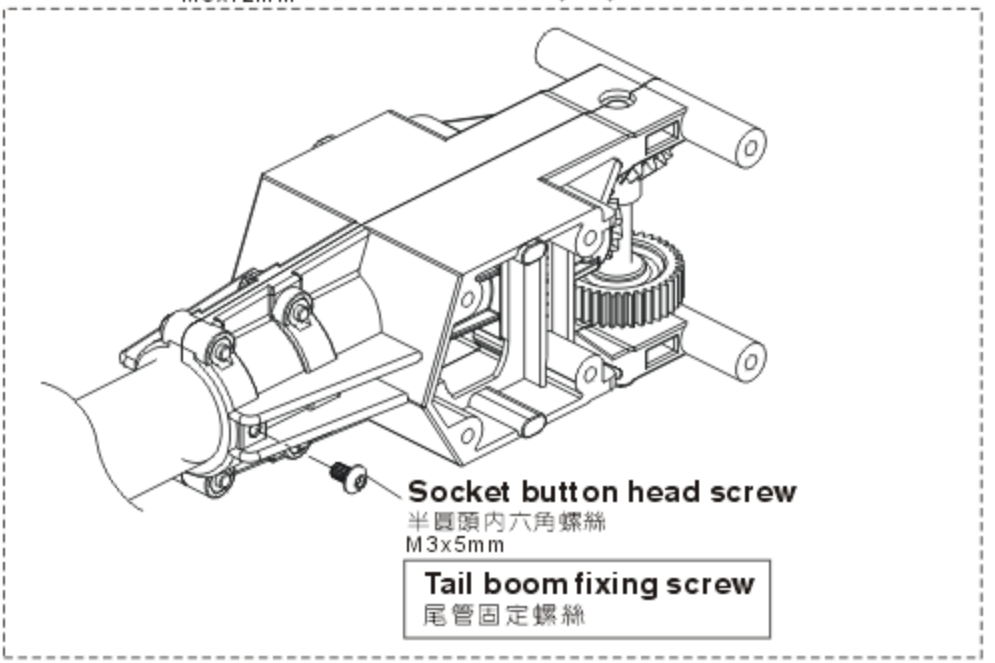

**Socket button head screw**  
半圓頭內六角螺絲  
M3x5mm

**Tail boom fixing screw**  
尾管固定螺絲

## 600NB3



**Socket collar screw**  
圓頭內六角軸套螺絲 (M3x20mm) x 1



**M3 Nut**  
M3防鬆螺帽 x 1

## 600NH8



**M4 Set screw**  
M4止洩螺絲 (M4x4mm) x 2

## 600NZ7



**Linkage rod(D)**  
連桿 (D) 約39.5mm x 2

## 600NZ7A



**Ball link**  
連桿頭 x 4

When tightening the main blade fixing screw, please tighten it firmly, but not over tighten, or it may cause the damage of main blade holder and result in danger.

鎖緊主旋翼螺絲須注意適當緊度即可，過緊可能導致主旋翼夾座受損，飛行意外發生。

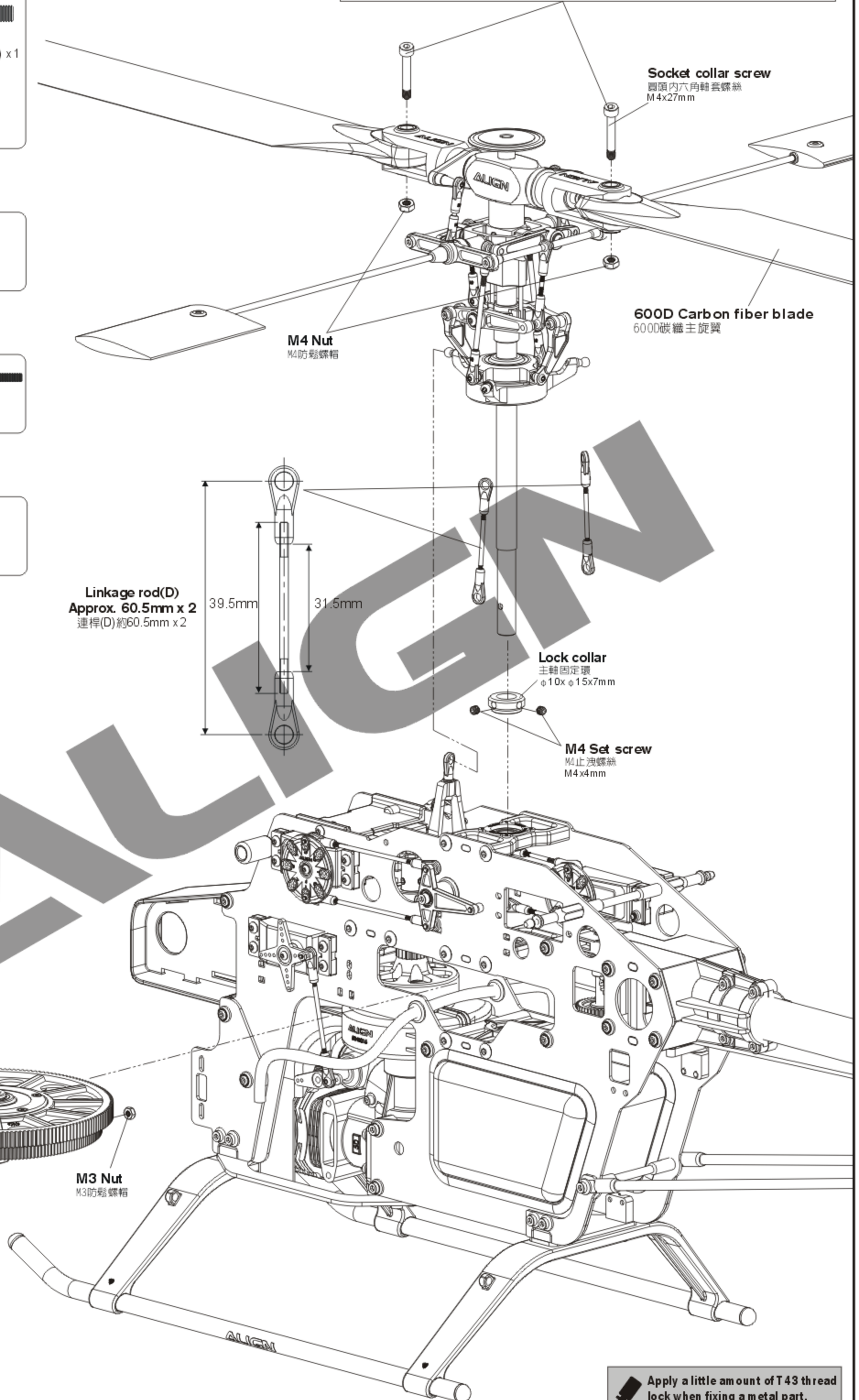

Apply a little amount of T43 thread lock when fixing a metal part.  
螺絲鎖附於金屬件請使用適量T43(螺絲膠)

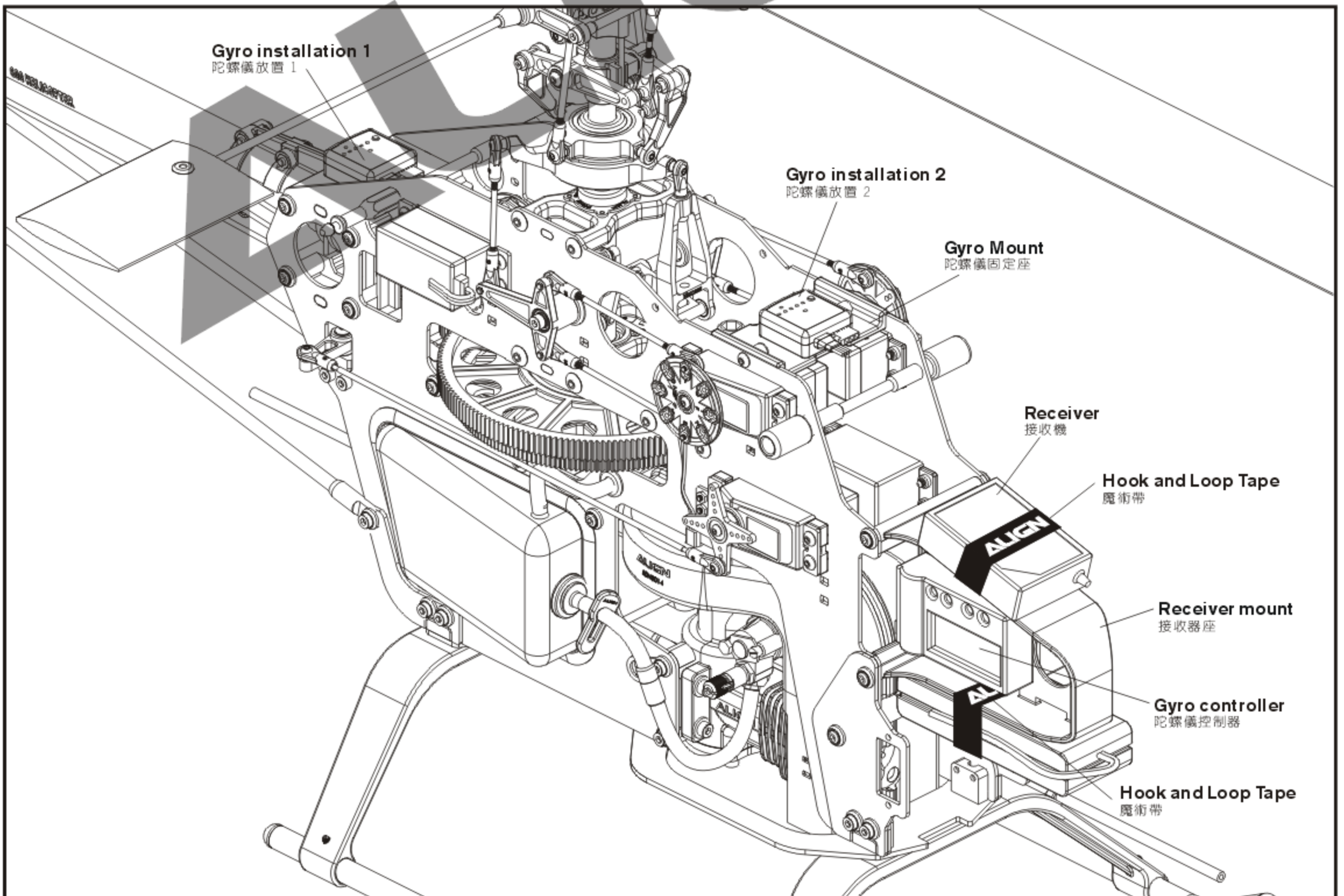
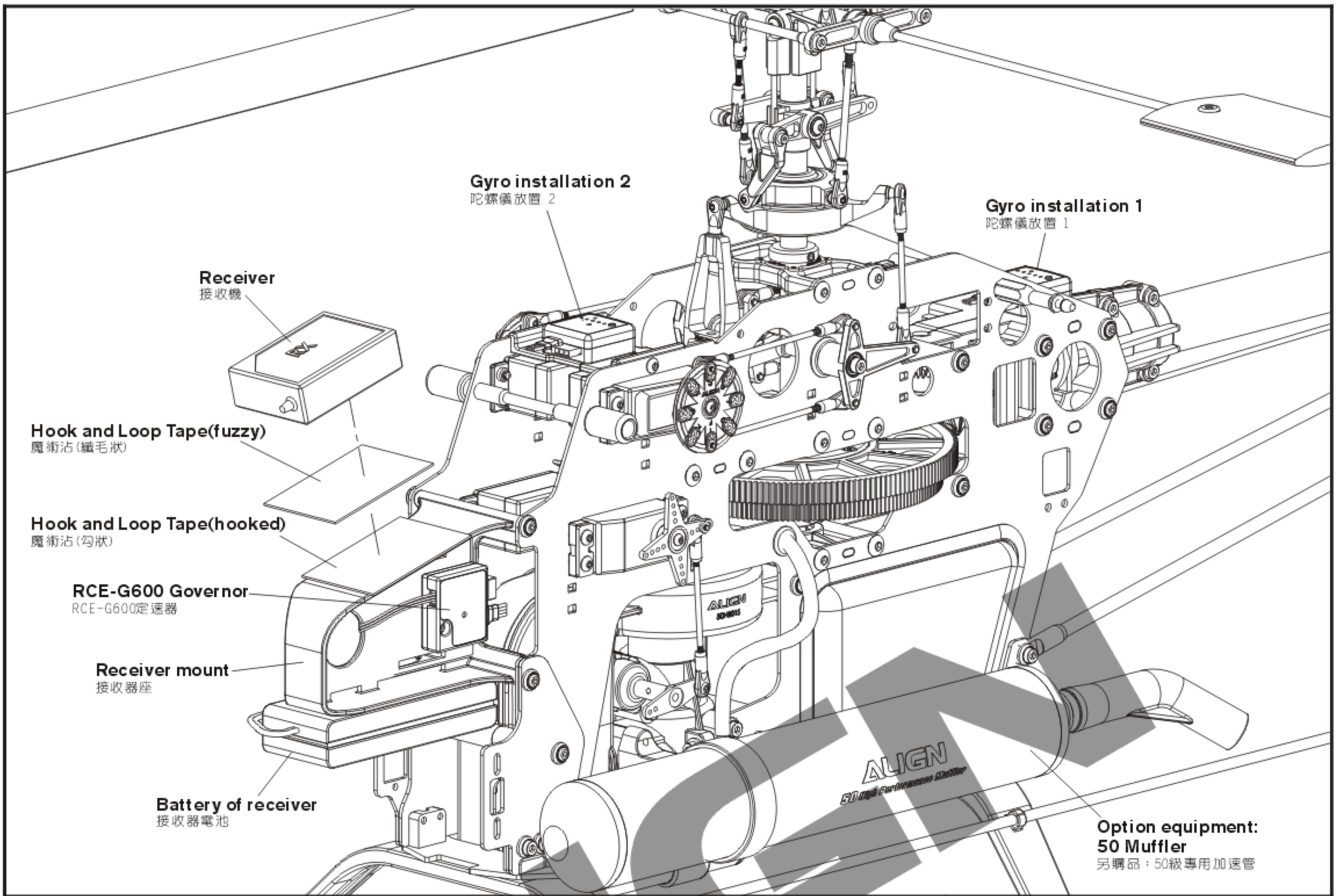

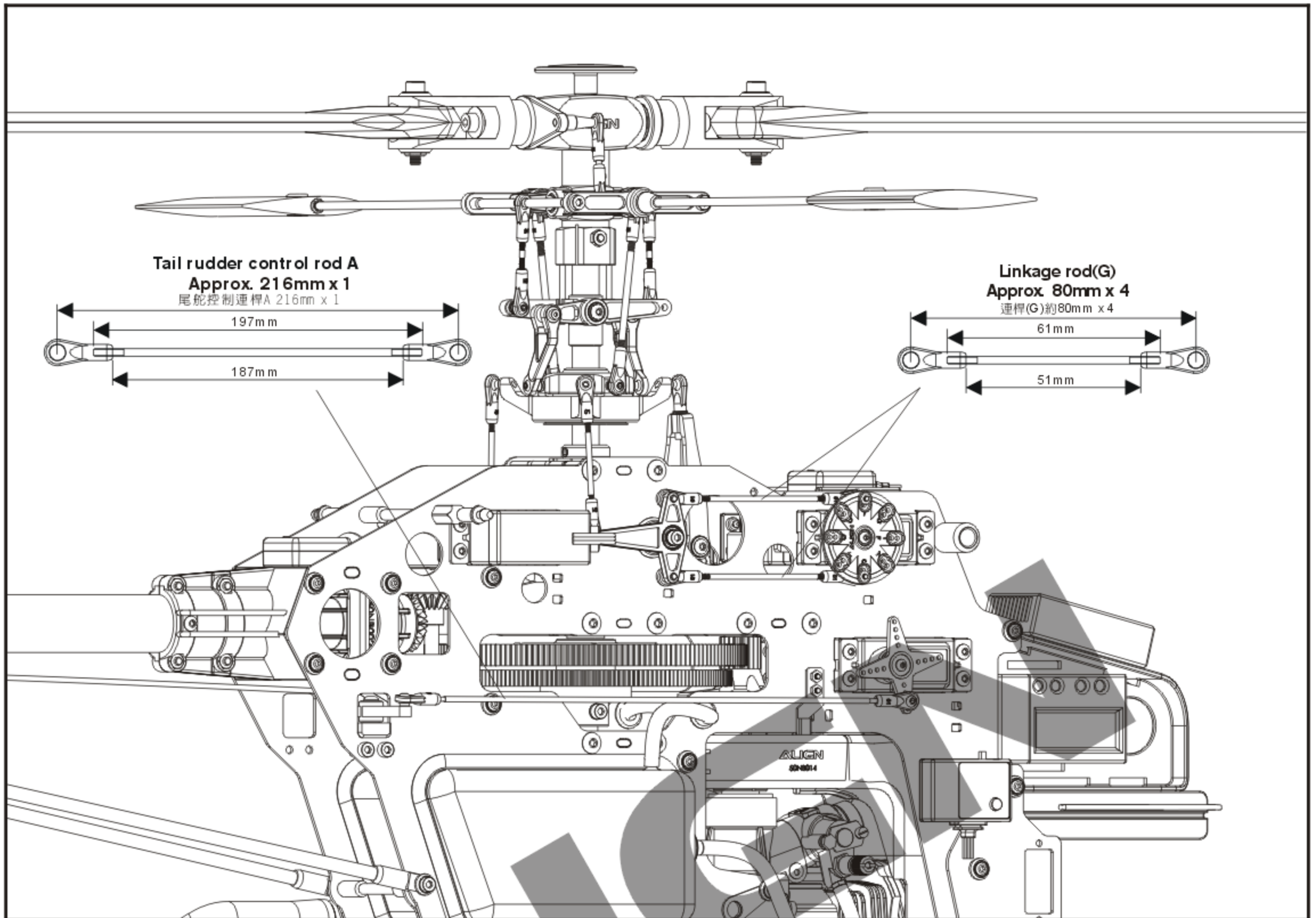

8.CANOPY ASSEMBLY 機頭罩安裝

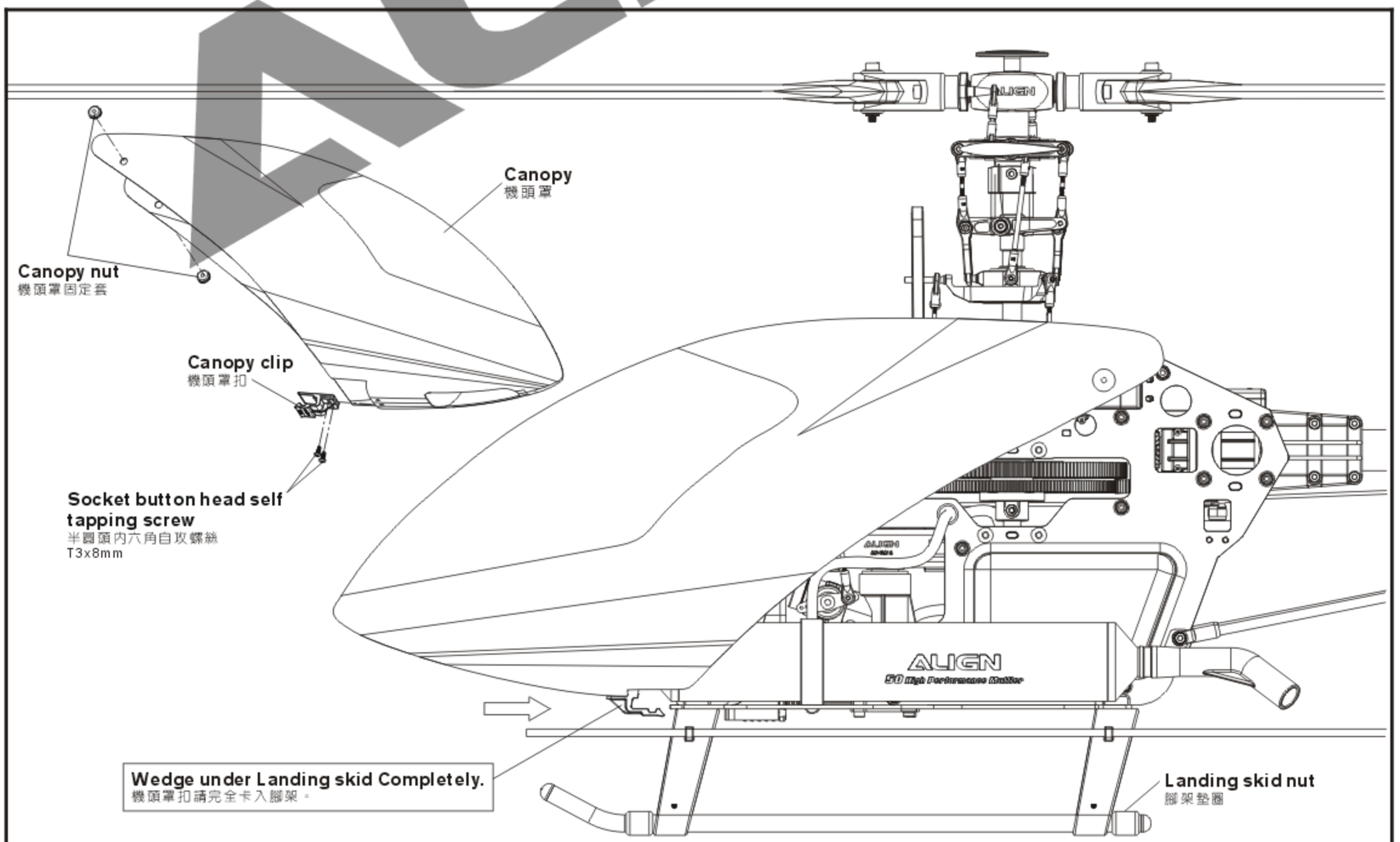



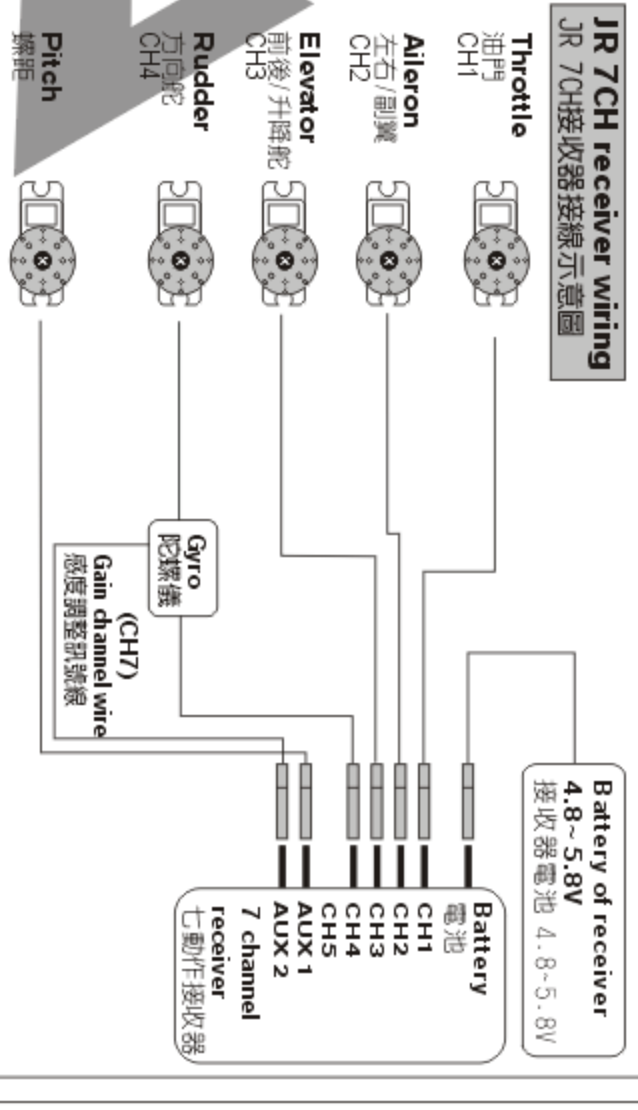
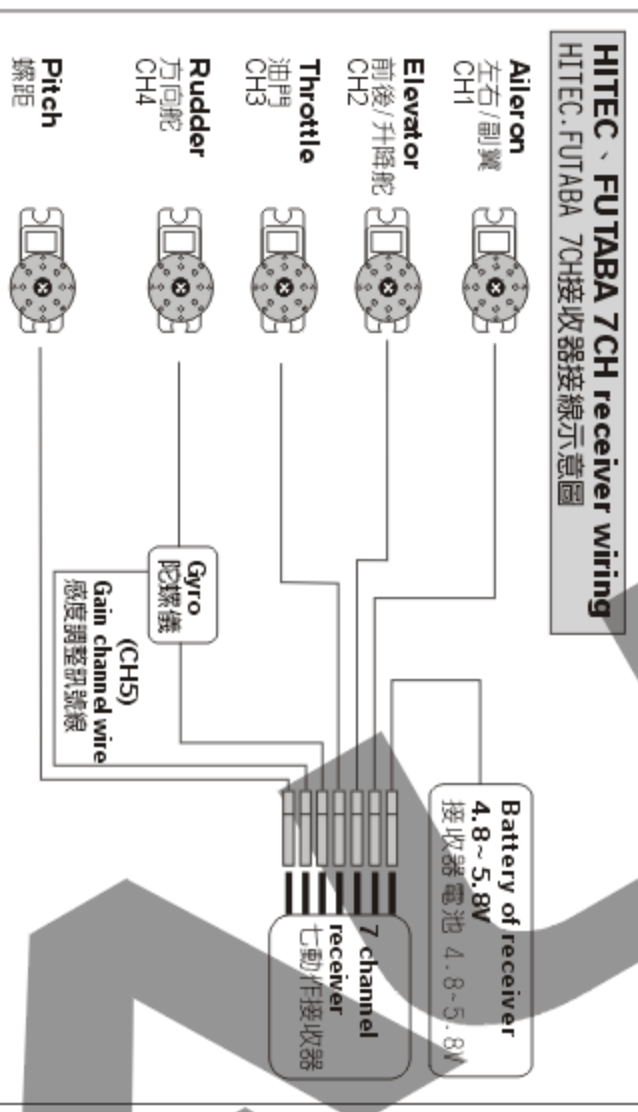
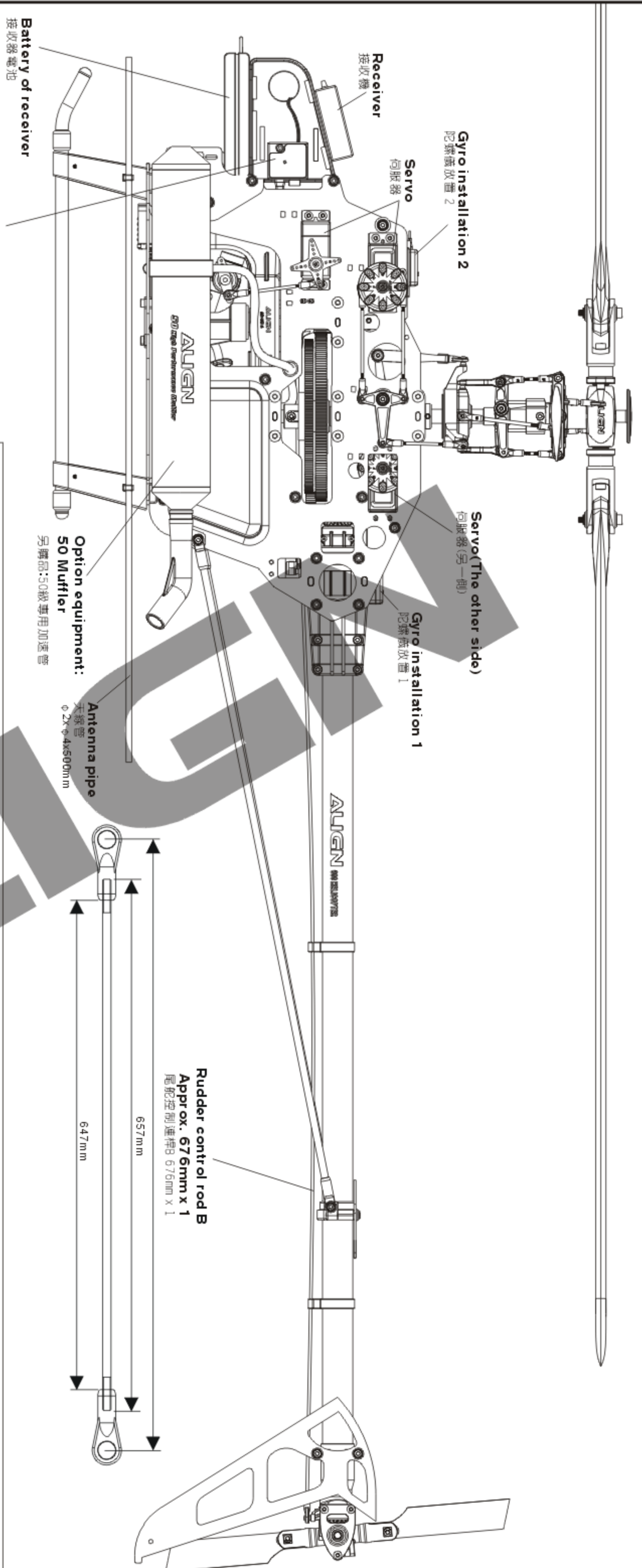

7-Channel Receiver is adequate for the requirements of the T-REX heli. You will need the following channels at a minimum: Throttle, Rudder, Elevator, Aileron, and especially Pitch(CH6) and Gyro(CH5) controls. 七動作的接收器已足夠應對T-REX遙控直升機的頻道需求，除了油門、方向舵、升降舵、副翼等基本動作外，亦可以對應具備感度調整訊號線的陀螺儀(CH5)與螺距(CH6)。

7-Channel Receiver is adequate for the requirements of the T-REX heli. You will need the following channels at a minimum: Throttle, Rudder, Elevator, Aileron, and especially Pitch(AUX 1)and Gyro(AUX 2) controls. 七動作的接收器已足夠應對T-REX遙控直升機的頻道需求，除了油門、方向舵、升降舵、副翼等基本動作外，亦可以對應具備感度調整訊號線的陀螺儀(AUX 2)與螺距(AUX 1)。

To set this option is to turn on the transmitter and connect to BEC power.  
此項設定只要開啓發射器，接上BEC電源即可進行操作。

**JR Transmitter/Servo**  
JR遙控器對應伺服器關係

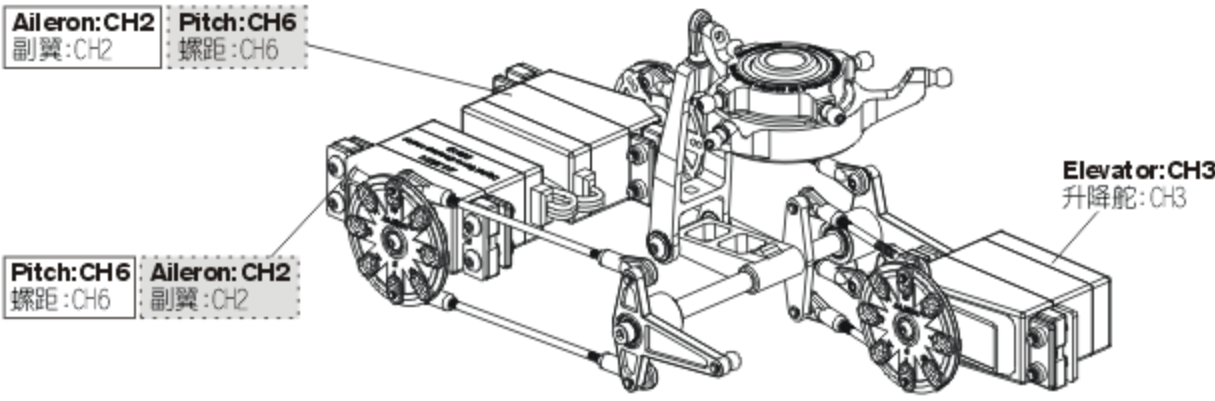

Positions of CH2、CH6 are exchangeable, After assembling as photo (Note:Set the transmitter under CCPM 120 degrees mode), pull throttle stick (pitch) upward. If one swashplate servo (or two servos) moves downward, adjust reverse switch (REV) on the transmitter to make it moves upward. If three servo move downward, adjust the travel value (+-) of SWASH CH6 on the transmitter to make them move upward. When the actions of Aileron and Elevator are opposite, adjust travel values of SWASH CH2 and CH3.

CH2、CH6可互換配置，依圖連結後(注意:遙控器須設定於CCPM 120°十字盤模式)，將油門搖桿(Pitch)往上推，若十字盤伺服器有1個或2個往下移時，請調整遙控器的反轉開關(REV)使伺服器往上，若3個伺服器同時往下移時，請調整遙控器SWASH CH6行程量的正負值，使伺服器同時往上平移，副翼與前後動作相反時，同樣調整 SWASH CH2、CH3行程量正負值。

**FUTABA/HITEC Transmitter/Servo**  
FUTABA/HITEC遙控器對應伺服器關係

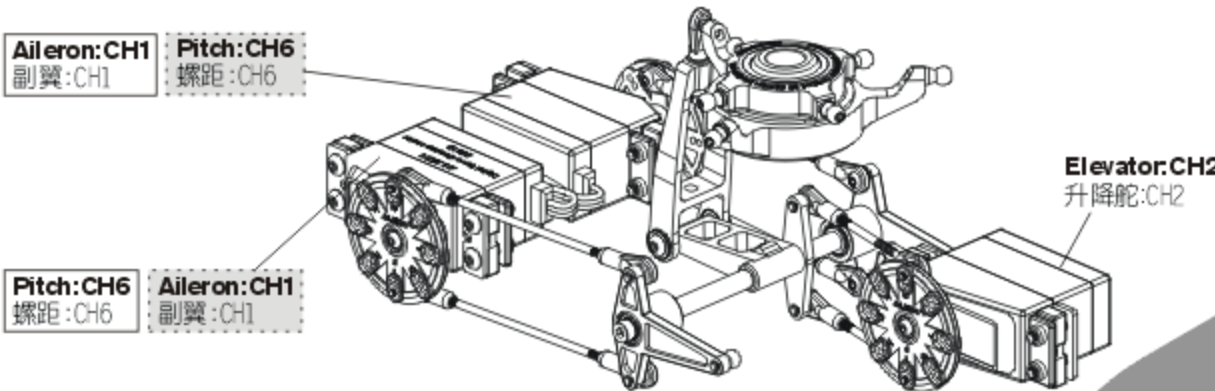

Positions of CH1、CH6 are exchangeable, After assembling as photo (Note:Set the transmitter under CCPM 120 degrees mode), pull throttle stick (pitch) upward. If one swashplate servo (or two servos) moves downward, adjust reverse switch (REV) on the transmitter to make it moves upward. If three servo move downward, adjust the travel value (+-) of SWASH CH6 on the transmitter to make them move upward. When the actions of Aileron and Elevator are opposite, adjust travel values of SWASH CH1 and CH2.

CH1、CH6可互換配置，依圖連結後(注意:遙控器須設定於CCPM 120°十字盤模式)，將油門搖桿(Pitch)往上推，若十字盤伺服器有1個或2個往下移時，請調整遙控器的反轉開關(REV)使伺服器往上，若3個伺服器同時往下移時，請調整遙控器SWASH CH6行程量的正負值，使伺服器同時往上平移，副翼與前後動作相反時，同樣調整 SWASH CH1、CH2行程量正負值。

11.AJUSTMENTS FOR GYRO AND TAIL NEUTRAL SETTING 陀螺儀與尾翼中立點設定調整

Recommend to choose Head Lock type for Gyro and turn off Revolution mixing(RVMX) mode on the transmitter, then set the gain switch on the transmitter and the gyro to Head lock mode. The gain setting is about 70%, and after transmitter setting, connect to BEC power to work on tail neutral setting. Note: When turn on BEC power, please do not touch tail rudder stick and the helicopter. Then wait for 3 seconds, make tail servo arm and tail servo at a right angle(90 degrees), tail pitch assembly must be correctly fixed about in the middle of the travel of tail rotor shaft for standard neutral setting.

陀螺儀選擇，建議選用鎖定式陀螺儀，其發射器內陀螺儀設定請關閉根軸混控模式，並將發射器上的感度開關與陀螺儀切至鎖定模式，感度設約 70% 左右，發射器設定完成後接上BEC接收電源，即可進行尾中立點設置。注意:當啟動BEC電源時請勿撥動尾舵搖桿或碰觸機體，待3秒陀螺儀鎖定後尾伺服器需與尾伺服器約成 90°，尾旋翼控制組須正確置於尾橫軸行程約中間位置，即為標準尾中立點設定。

**TAIL NEUTRAL SETTING 尾中立點設定**

After setting Head Lock mode, correct setting position of tail servo and tail pitch assembly is as photo. If the tail pitch assembly is not at the neutral position, please adjust the length of rudder control rod to trim.

陀螺儀鎖定後尾伺服器與尾 Pitch控制組正確擺置位置。若尾 Pitch控制組未置中時請調整尾控制連桿的長度來修正。

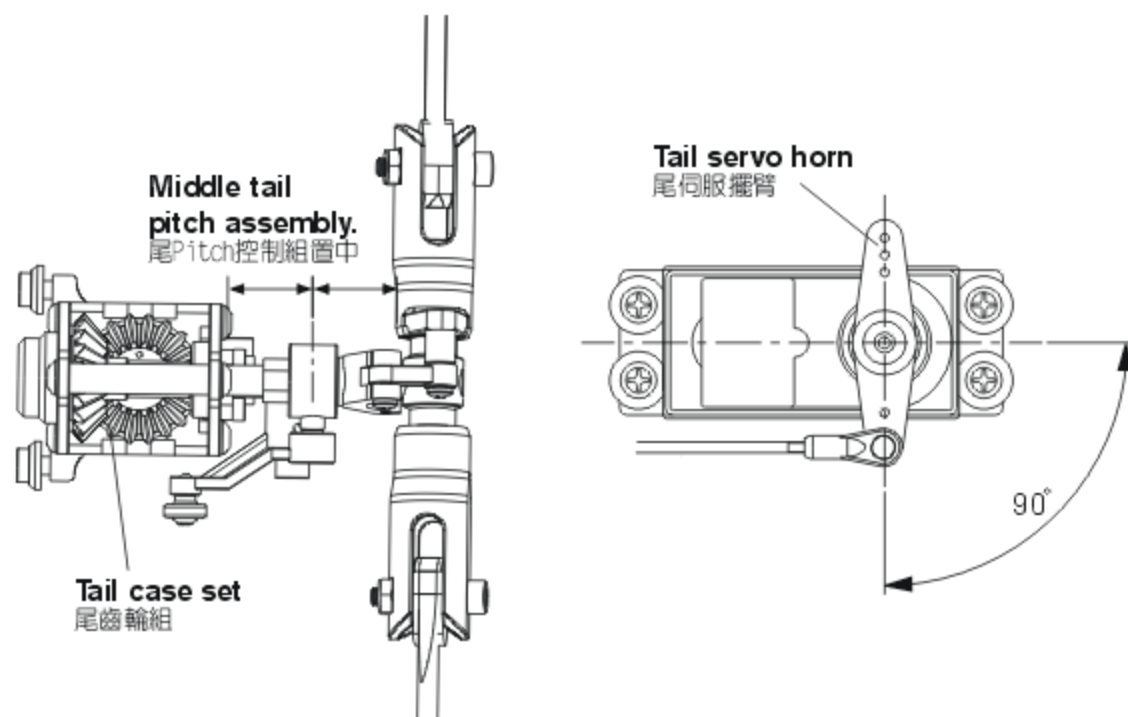

**HEAD LOCK DIRECTION SETTING OF GYRO 陀螺儀鎖定方向設定**

To check the head lock direction of gyro is to move the tail counterclockwise and the tail servo horn will be trimmed clockwise. If it trims in the reverse direction, please switch the gyro to "REVERSE".

陀螺儀鎖定方向確認，當手搖尾部反時鐘擺動，尾伺服器應順時鐘修正，反向時請切換陀螺儀上"鎖定反向"開關修正。

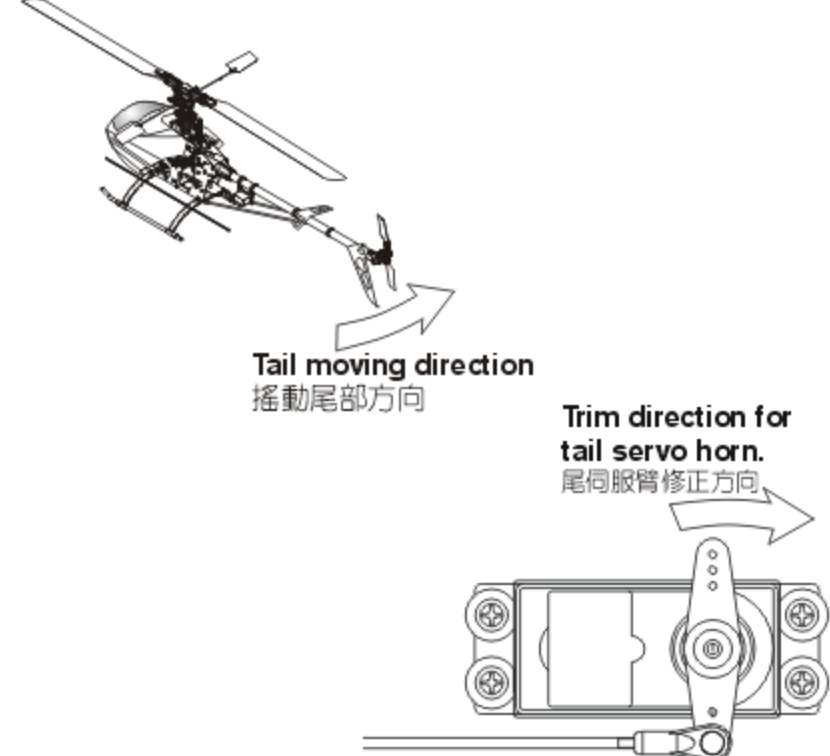

## GENERAL FLIGHT 一般飛行模式

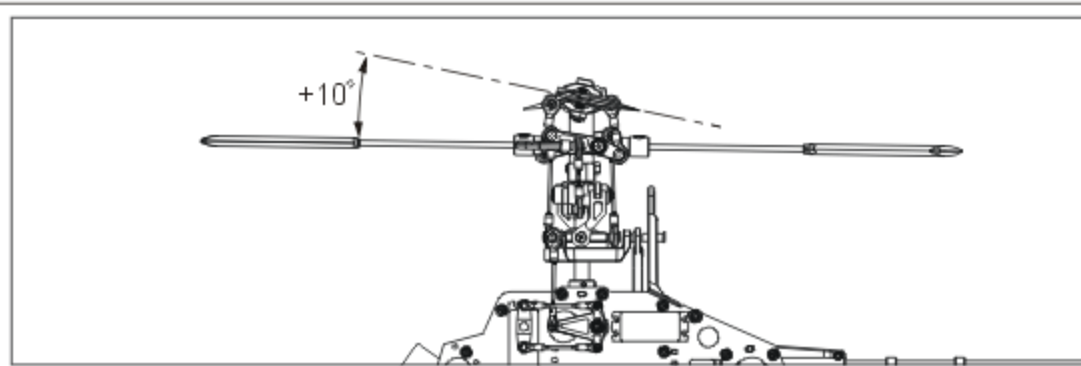

Stick position at high/Throttle 100%/Pitch +10°  
搖桿高速/油門100%/Pitch+10°

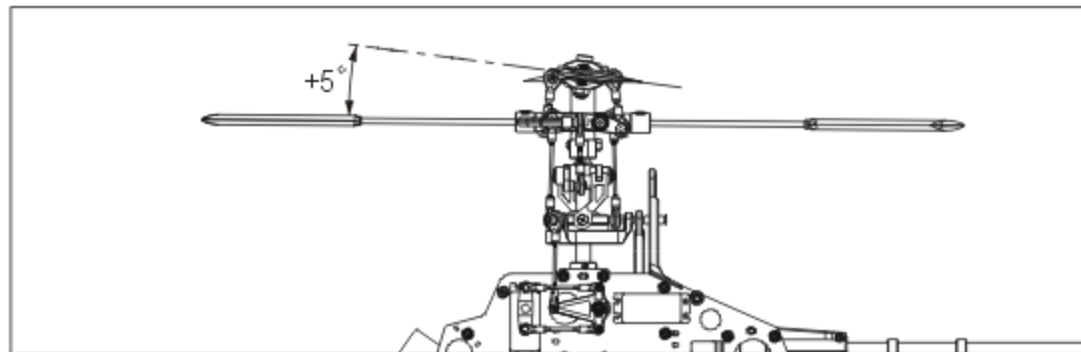

Stick position at Hovering/Throttle 60%/ Pitch+5°  
搖桿停懸/油門60%/Pitch+5°

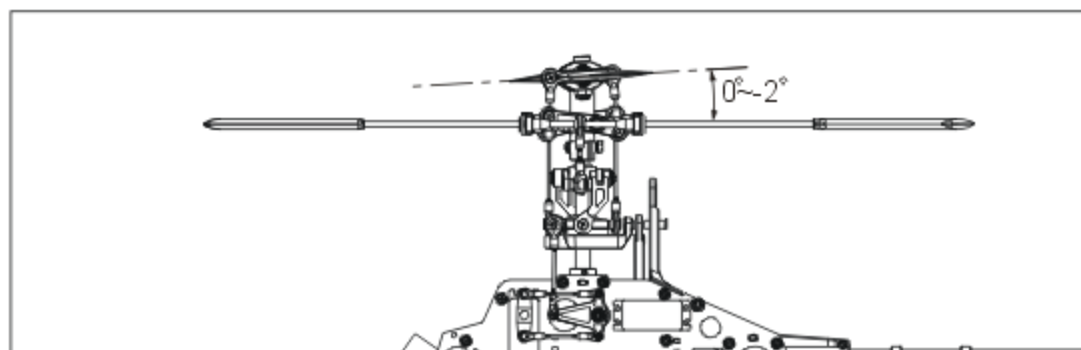

Stick position at low/Throttle 0%/Pitch 0°~-2°  
搖桿低速/油門0%/Pitch 0°~-2°

### GENERAL FLIGHT 一般飛行模式

	Throttle 油門	Pitch 螺距
5	100% High speed 100% 高速	+10°
4	80%	
3	60% Hovering 60% 停懸	+5°
2	40%	
1	0% Low speed 0% 低速	0°~-2°

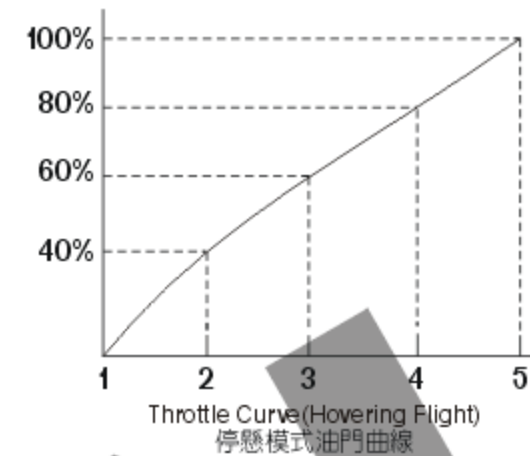

## 3D FLIGHT 3D特技飛行模式

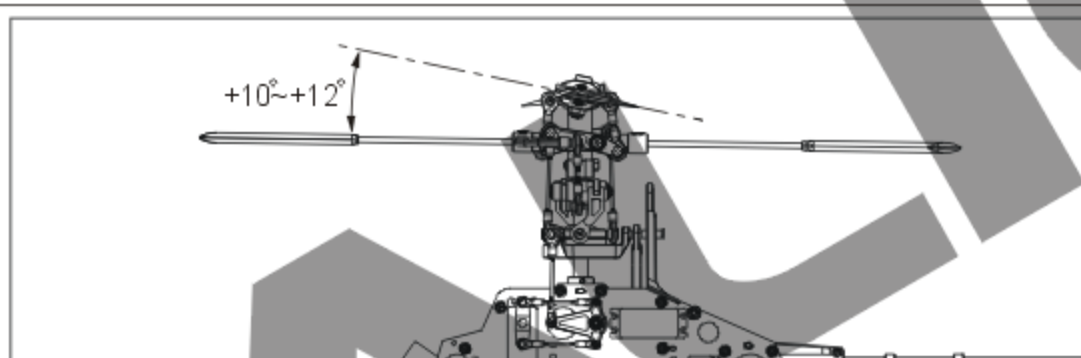

Stick position at high/Throttle 100%/Pitch +10°~+12°  
搖桿高速/油門100%/Pitch+10°+12°

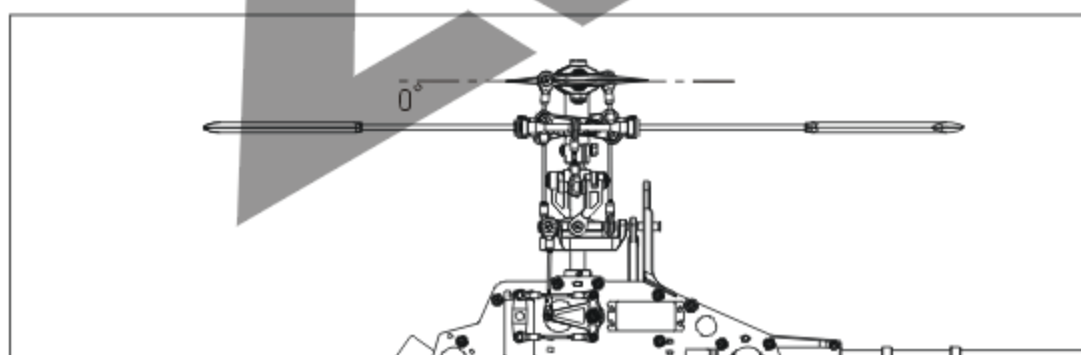

Stick position at middle/Throttle 85%/Pitch 0°  
搖桿中速/油門60%-65%/Pitch 0°

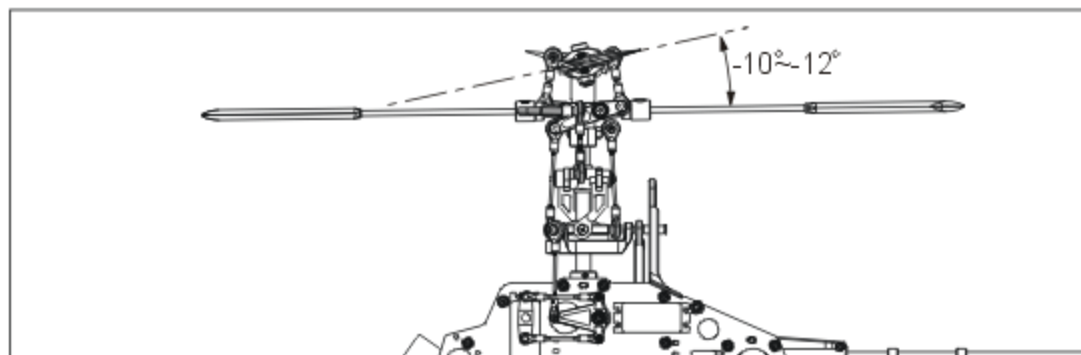

Stick position at low/Throttle 100%/Pitch -10°~-12°  
搖桿低速/油門100%/Pitch-10°~-12°

### IDLE 1: SPORT FLIGHT

	Throttle 油門	Pitch 螺距
5	100%	+10°~+12°
4	75%	
3	60%	+5°
2	65%	
1	70%	-5°

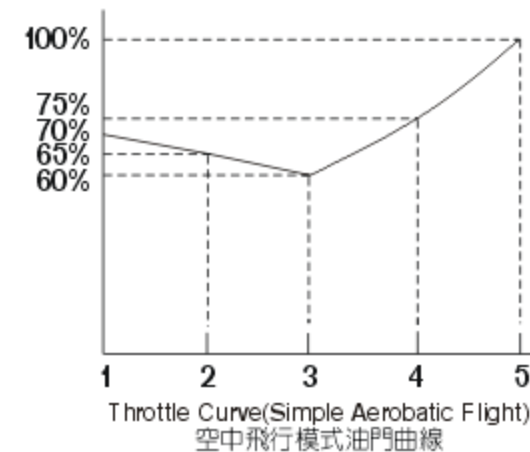

### IDLE 2: 3D FLIGHT

	Throttle 油門	Pitch 螺距
5	100% High 100% 高	+10°~+12°
3	60%~65% Middle 60%-65% 中	0°
1	100% Low 100% 低	-10°~-12°

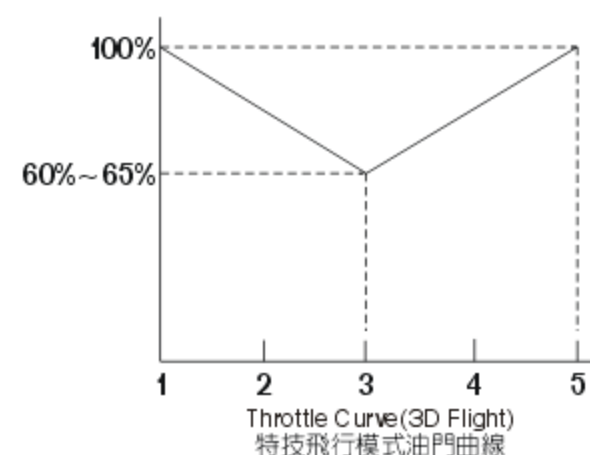

1. Pitch range: Approx. ±14 degrees.
2. If the pitch is set too high, it may cause motor overload.



1. 螺距 (Pitch) 總行程約 ±14°
2. 過大螺距設定，可能導致引擎過載。

**Features 功能說明**

1. Compact design, easy use, simple setting with great speed control performance.
2. Speed resolution: 0.1RPM
3. Speed stability accuracy: within 1% (Steady State)
4. Not apply to S9251、S9256 and other 760 μs servos.

1. 造型精巧操作簡易，不需繁雜的設定，同樣有優異的定速表現。
2. 轉速解析度0.1 RPM。
3. 轉速控制精度1%以內 (steady state)。
4. 不適用S9251、S9256等760 μs伺服器。

**Specifications 產品規格/配件**

1. Operating voltage: DC 4.5V-6V
2. Consumption current: <20mA@4.8V
3. Direct detection of engine rotation speed
4. Speed control range: 10500~21000RPM
5. Servo RWM output pulse width: 1~2ms, not apply to S9251, S9256, other 760 μs servos.
6. Operating temperature range: -20°C~85°C
7. Operating moisture range: 0%~95%
8. Case size (body): 28.5x26.2x9mm
9. Signal wire length: 160mm
10. Sensor wire length: 250mm
11. Weight: 10g (including wires)
12. Accessories: Magnet x2pcs  
Screw (T2.6x6) x2pcs  
Sensor Nut x 1pc

1. 工作電壓: DC 4.5V-6V。
2. 消耗電流: <20mA@4.8V。
3. 直接偵測引擎轉速。
4. 定速範圍: 10500-21000RPM。
5. 伺服器PWM輸出波寬1-2ms，不適用 S9251、S9256等760 μs伺服器。
6. 工作溫度範圍-20°C-85°C。
7. 工作濕度範圍: 0%-95%。
8. 本體外殼尺寸: 28.5x26.2x9mm。
9. 訊號線長: 160mm。
10. 轉速感應線長: 250mm。
11. 重量: 10g (含線組)。
12. 配件: 轉速感應磁鐵x2pcs。  
半圓頭內六角螺絲 (T2.6x6) x2pcs。  
感知器固定螺帽x1pcs。

**Instruction 安裝使用說明**

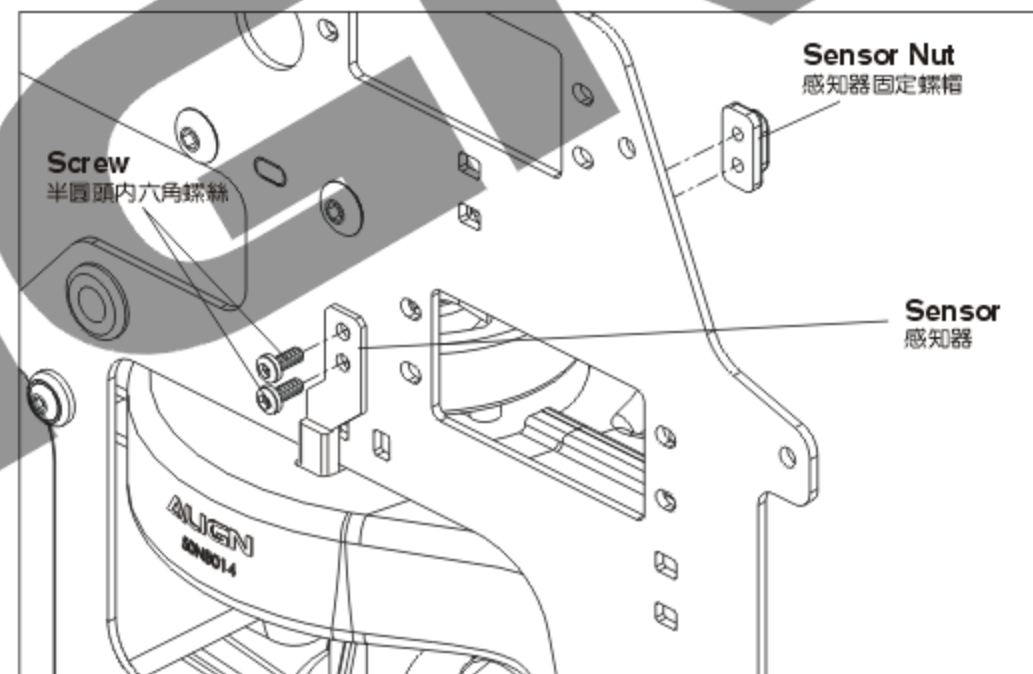
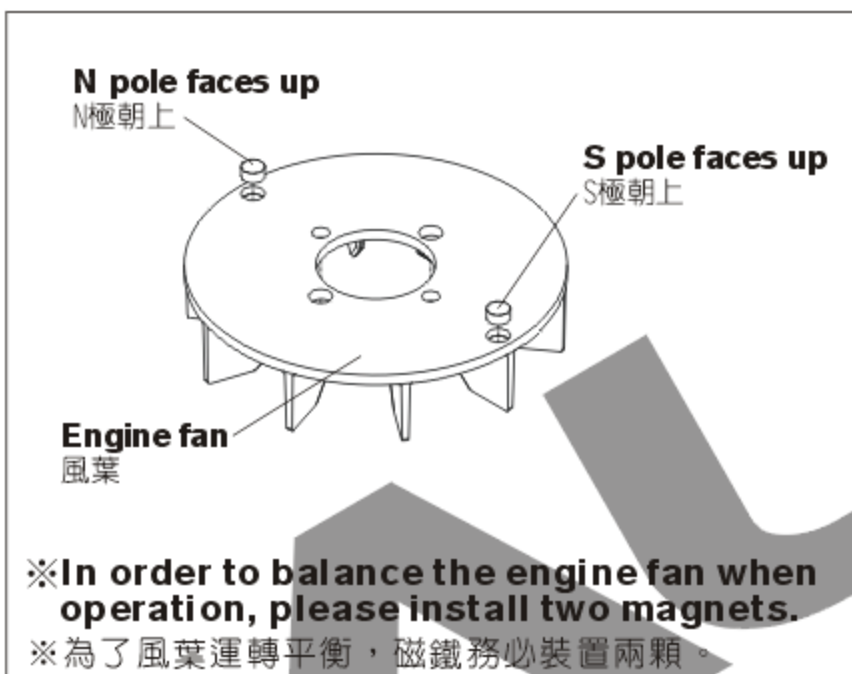

1. See Fig. 1, first install two magnets on the mounting hole of the engine fan with CA glue or R48 glue, the north pole of one magnet (mark N) faces up and the north pole of the other magnet faces down.  
NOTE: Magnets must be firmly secured. If the magnet falls from the engine fan during the flight, the governor will automatically cut out the speed control function.
2. See Fig. 2, install the sensor on the main frame, and check if any interference caused by the engine fan.
3. Before connecting to the governor, first please check the rotation direction (clockwise/anti-clockwise) of throttle servo and travel range are correct.
4. Choose an un-used switch for governor ON/OFF switch. Connect the yellow sign wire of the governor to the receiver's channel. Then connect the governor to the power and make sure that turning on the switch is for Governor ON and off is for Governor OFF. (Green LED light is governor ON mode, and Red LED light is governor OFF mode)
5. When connecting the governor to the power, LED light is on. When the magnet is lapped over the sensor, the LED light will be off. (If the LED isn't off, please check the polarity of the magnet and check if the wire is well connected and check for the distance between the sensor and the magnet.)
6. Adjustment of throttle travel: First place the throttle stick at the lowest position, and then turn on the transmitter. After that turn on the receiver. When the LED light is on, press "Throttle Travel Setting" button on the governor for 3 seconds. While the LED light flash, please place the throttle stick at the highest position. Then the LED light will be off and later be on again, it means the setting is completed.  
NOTE: Do not run the engine before completing the throttle limit setting, to avoid the throttle travel error or servo reversion.
7. When normal, the throttle curve is straight (0%/50%/100%). When Idle, the throttle curve cannot be lower than 50%. When the governor fails, it will go back to the governor OFF mode. Therefore, even though you have installed the governor, the throttle curve of transmitter must be set as regular setting.
8. Two conditions- Governor will be enabled:  
(1) Turn on the governor switch, and LED light is green. (2) Throttle position > 30% and more.
9. When the governor turns on, the rotation speed of the engine is controlled by the ATV (%) which is the channel chosen on the 4<sup>th</sup> step. The following chart is ATV setting and engine rotation speed for Futaba and JR transmitters. The rotation speed of main blade is converted according to the engine ratio of original helicopter.

1. 如圖一先將轉速感應磁鐵一顆 N 極朝上 (作記號的面為 N 極)，一顆 N 極朝下，以 CA 或 R48 黏著在引擎風葉預留的磁鐵座上。  
※注意:磁鐵須固定牢靠，若飛行中磁鐵不慎脫落，定速器將自動取消定速功能。
2. 如圖二標示之位置將轉速感知器安裝於側板上，並檢查是否與風葉產生干涉的情形。
3. 連接定速器前，先確定油門伺服器正逆轉及機械行程是否正確。
4. 選一個遙控器上未使用的通道開關，作為定速與非定速的切換開關，並將定速器的黃色訊號線接到接收器上對應此開關的通道，接著將定速器接上電源後撥動此開關，以確定開啓是定速模式，及關閉是非定速模式 (於定速模式時定速器上的 LED 為綠燈，非定速模式 LED 為紅燈)。
5. 定速器接上電源後，LED 恆亮，當磁鐵與感知器重合時，LED 會熄滅。  
(如 LED 未熄滅，需檢查磁鐵極性是否正確？線路連接是否正確？感知器及磁鐵距離是否正確？)
6. 油門行程的校正：先將油門置於最低點的位置，將發射機電源打開，開啓接收機電源，當 LED 亮起後按定速器上的設定鍵三秒後，此時 LED 會閃爍，接著將油門撥桿推到最高點位置，稍等 LED 會先熄滅後重新亮起，即完成設定作業。  
※注意:未執行定速器油門行程設定前切勿發動引擎，以免油門行程錯誤或發生伺服器反向之情形。
7. 油門曲線在 normal 時為直線 (0%/50%/100%)，idle 油門曲線最低點不可低於 50%，即使有安裝定速器，遙控器的油門曲線仍要依照正常的模式來設定，因為當定速器失效時會返回非定速模式。
8. 定速器的啓動條件有二項：(1) 定速器開關開啓，LED 亮綠燈。(2) 油門位置 >30% 以上。
9. 當啓動定速功能時，引擎的轉速即交由第 4 步驟所選定通道的行程量 (ATV) 百分比 (%) 來進行控制，下表為 Futaba 與 JR 遙控器 ATV 設定值與引擎轉速的對照表，主旋翼的轉速請依原廠直昇機的引擎齒比換算。

ATV	FUTABA PCM 1024Z		FUTABA T14MZ		JR PCM10S&9X	
	Engine speed 引擎轉速	T-REX 600NSP Main blade speed8.5:1 主旋翼轉速8.5:1	Engine speed 引擎轉速	T-REX 600NSP Main blade speed8.5:1 主旋翼轉速8.5:1	Engine speed 引擎轉速	T-REX 600NSP Main blade speed8.5:1 主旋翼轉速8.5:1
10%	10500	1235	10500	1235	10500	1235
20%	10500	1235	10500	1235	10500	1235
30%	12000	1412	10800	1271	10500	1235
40%	13700	1612	12000	1412	11200	1318
50%	15400	1812	13300	1565	12400	1459
60%	17070	2008	14550	1712	13600	1581
70%	18760	2207	15800	1859	14850	1747
80%	20410	2401	17100	2012	16000	1882
90%	21000	2470	18340	2158	17200	2024
100%	21000	2470	19700	2318	18450	2171
110%	21000	2470	20860	2454	19640	2311
120%	21000	2470	21000	2470	20760	2442
130%	21000	2470	21000	2470	21000	2470
140%	21000	2470	21000	2470	21000	2470
150%	21000	2470	21000	2470	21000	2470

**NOTE: If the LED light is off, please check if the magnet is lapped over the sensor. Please turn the magnet position of engine fan to let the LED light on.**

註如開機時定速器燈沒亮，有可能是磁鐵跟感知器重合，請轉動風葉磁鐵位置，讓指示燈亮起。

**Features 功能說明**

1. Due to the unique 2 in 1 design, the regulator's functions provide power to the receiver, servos, and the internal glow plug ignition system that does not require you to remove the clip lead.
2. The linear regulator design results in no interference to the receiver. The required input power may only consist of a 2 cell Li-ion or a Li-Poly battery.
3. When the integrated power switch is moved to the on position, the voltage indicating LED's and ignition indicating LED's will illuminate displaying the status of the battery voltage, and of the plug ignition function.

1. 獨特的二合一設計，除了具備(BEC)降/穩壓系統，以提供接收器與伺服器電源的功能外，還內建一組火星塞的點火裝置，省卻傳統電夾插拔的麻煩。
2. 本產品採用線性設計，輸入電源為2CELL的Li-ion或Li-Poly電池，其優點為不會像交換式設計的BEC會產生干擾接收器的情形，免於摔機的恐懼。
3. 具備電源開關、電壓指示燈及點火指示燈功能，可由燈號判定電池殘量與火星塞的點火狀態。

**Specifications 產品規格/配件**

1. Input Voltage: DC 7.4V 2 cell Lithium or Li-Poly battery
2. Output Voltage: DC 5.8V(BEC)/1.5V(Glow Plug)
3. Max. Continuous Current: 6A
4. Weight: 53.5g (including wires)
5. Regulator size: 80x30x13.3mm  
Control board size: 35x24x10mm

1. 輸入電壓: DC 7.4V 2CELL 鋰電
2. 輸出電壓: DC 5.8V (BEC) / 1.5V (Glow Plug)
3. 最大連續輸出電流: 6安培
4. 重量: 53.5g (含線組)
5. 尺寸: 降壓器 80x30x13.3mm  
控制板 35x24x10mm

**Instruction 安裝使用說明****Receiver and Servo Voltage Regulating Functions:**

1. The Auto-detecting voltage LED's will display a series of lights when turned on. If the entire five-light array is illuminated then the battery is fully charged. When the voltage drops below 7.6V the three green lights will turn off. USE CAUTION: Once the green lights are no longer illuminated the battery can only be safely used for a single flight. When only the single red LED is lit, DO NOT ATTEMPT TO OPERATE THE MODEL. The battery voltage has been drained too low, and must be recharged before its next use.
2. It is important to note that not all servos are designed to operate on 6 volts, such as Futaba servo models 9241, 9251, 9253, 9254, 9255, 9256 and other digital servo are not capable of handling 6V. Please check with the manufacturing specifications of the servo before attempting to operate. A separate 5.1V inline voltage Step-Down may be purchased and is recommended for use between the gyro and the tail servo, and any servos that are not designed to handle 6V. Please note that some servos are designed for running on 6V and may not require a voltage step-down.

**接收器與伺服器電源部份:**

1. 本產品具電壓指示功能，當接入充飽的電池時五顆指示燈全亮，表示電池在Full電量充足狀態下；使用中當電壓降低至7.6V時(3顆綠燈熄滅)，尚可完成單趟飛行即須對電池充電或更換新電池；而如果僅亮紅燈時表示Empty電量不足，不應該再使用囉！
2. 部份的伺服器如:Futaba 9241, 9251, 9253, 9254, 9255, 9256等，此類型的伺服器不適合於較高的電壓下操作，所以使用此類型的伺服器時請另外加裝5.1V降壓調整器於陀螺儀與尾舵伺服器間，避免伺服器損壞；規格標標準許6V輸入的伺服器則不須使用調整器。

**Glow Plug Ignition System Functions:**

1. Start by connecting the wires using the included diagram as a reference. Once completed connect the battery and move the power switch to the on position. Depress the "START" button on the control board. The green and the orange lights will illuminate. When this happens the glow plug is being ignited for a period of 15 seconds. After 15 seconds, the control board will stop igniting the glow plug. If the engine has not yet been started, the process can be repeated by simply repressing the "START" button. The Ignition system is designed to automatically shut off once the engine starts running. To ensure that the system is operating properly, check to make sure that the orange and green lights have shut off once the engine starts running. In the event that the lights are still illuminated once the engine is running, it may be necessary to remove the lead clip from the engine.
2. If the orange light is not illuminated after pressing "START" then this means that the glow plug is not being ignited. Please check to see if the element of the glow plug has burned out, or if the lead clip is not properly connected to the glow plug.
3. If the Glow plug is short-circuited or the lead clip has contacted the outer case of the engine, the red (SHORT) light will be illuminated approx. 1 second after pressing the "START" button. If the "SHORT" light illuminates the system will automatically shut off the power to the output leads.

**火星塞點火器部分:**

1. 依接線示意圖完成接線後，開啓電源開關，接著按下控制電路板上的"START"鍵，此時點火指示燈的綠燈與橘燈同時亮起，表示火星塞已正常點火中，每次點火時間約為15秒，15秒後自動關閉，如需再次點火時，則再按一次"START"鍵；由於點火裝置會自動關閉，所以引擎啟動後，確認橘色、綠色指示燈於15秒後熄滅，即不須將鱷魚夾移除。
2. 若按下"START"鍵時，橘燈不亮，表示火星塞未正常點火，請檢查火星塞加熱線圈是否開路損壞，或是鱷魚夾未確實夾在火星塞電極端上。
3. 如果火星塞發生短路或是鱷魚夾(電源正端)與引擎外殼接觸時，當按下"START"鍵，紅色(SHORT)指示燈會亮起，約1秒後熄滅並隨即關閉電源輸出，請檢查火星塞是否損壞或檢查鱷魚夾是否接觸到引擎外殼。

**NOTE: Please use double-sided foam tape or hook & loop tap to fix the regulator on the helicopter. Please do not tighten the wires of regulator hard to avoid the wires loose or broken caused by the vibration during the operation of the helicopter.**

注意: 請使用泡綿雙面膠或魔術沾將降壓器與直昇機固定，降壓器的各線組請勿繃緊固定，以免直昇機運轉時因震動造成接頭鬆脫或斷線。

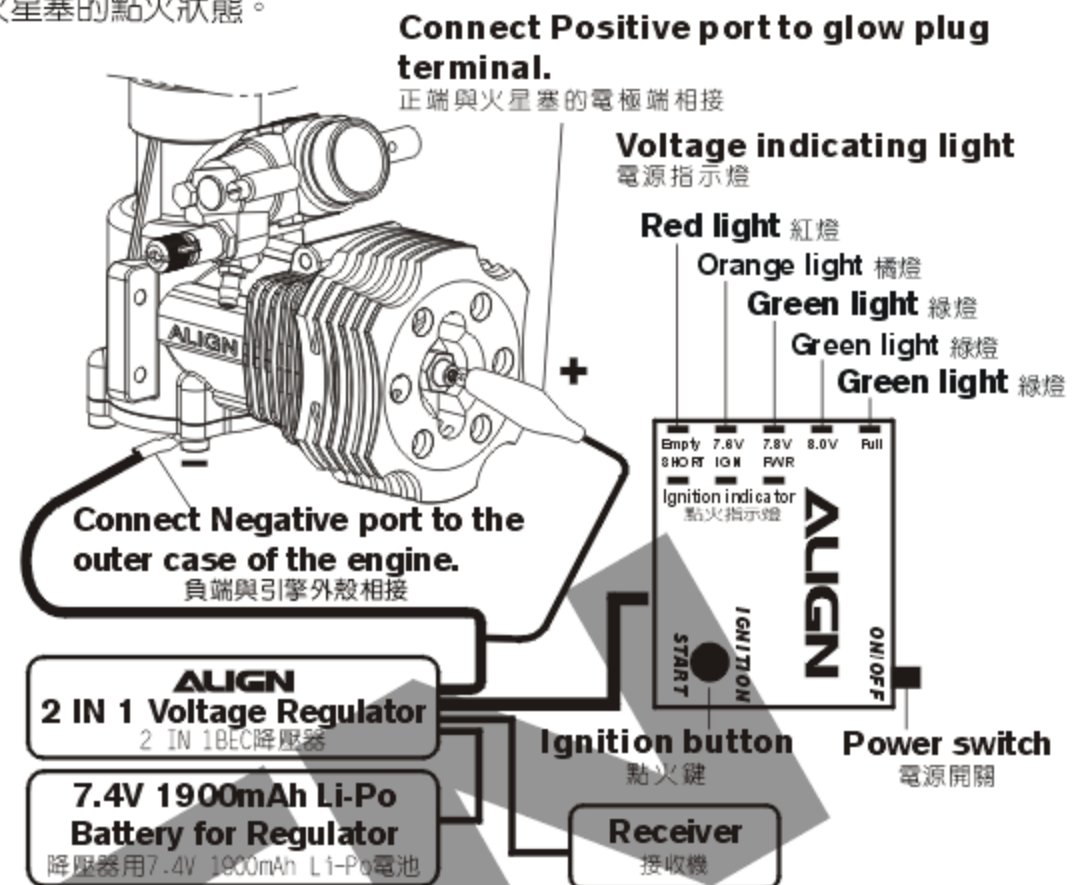

Features 產品特色

- Utilizes Silicon Micro Machines (S.M.M) sensor with excellent stability to dramatically reduce in-flight tail drifts.
- Utilizes AHTCS (Active Helicopter Tail Control System) to compensate any drift caused by wind direction and force, as well as unintended yaw induced by helicopter itself during flight maneuvers.
- Tailor made specifically for use with high speed digital rudder servos. This gyro features high sensitivity and minimal reaction time, fully utilizing the potential of modern high speed digital rudder servos.
- Suitable for all sizes of helicopters, from micro indoor to large 90 size glow helicopters.
- Metallic dampening plate built into bottom gyro casing, dramatically increasing anti-vibration and anti-interference abilities.
- Features 1520  $\mu$ s pulse wide and 760  $\mu$ s narrow pulse wide frame rate.
- Digital/Analog servo switchable.
- Reverse switch.
- Rudder servo travel limit adjustment (ATV).
- Mode switch for large/mini helicopter.
- Delay adjustment.
- Gyro locking mode and gain can be adjusted remotely from the transmitter.
- 採用S.M.M矽微細加工技術感知器，具有極佳的穩定性，大幅降低尾舵偏移的機會。
- 採用AHTCS (Active Helicopter Tail Control System)主動式直昇機尾旋翼控制系統，主動修正因風向、風力變化與直昇機不同飛行姿態所產生之偏移。
- 專為高速型數位伺服器量身打造，具有高靈敏度與極短的反應時間，完全發揮伺服器高速反應的鎖定能力。
- 適用迷你型室內電直至大型90油直。
- 下蓋與金屬防震片一體成型，大幅提升抗震防干擾能力。
- 相容標準1520  $\mu$ s與窄頻760  $\mu$ s伺服器。
- 數位/類比伺服器切換。
- 尾舵正逆向控制切換。
- LIMIT尾舵行程量設定。
- 大/小型直昇機模式切換。
- DELAY控制延遲量設定。
- 可由遙控器控制鎖定與非鎖定模式，以及調整陀螺儀感度。

Setting type 設定項目	1520/760 $\mu$ s	DS/AS	NOR / REV	LIMIT	Helicopter mode / DELAY 直昇機模式/DELAY
"STATUS" green "STATUS"綠燈	▲ Standard 1520 $\mu$ s Servo ▲標準1520 $\mu$ s伺服器	▲ Digital servo ▲DS數位伺服器	▲ Normal rotation ▲NOR正轉	Left(Right) Travel limit 左(右)行程量	Medium/ large heli, suitable for T-REX 500/600/700 中型/大型直昇機 適用T-REX 500/600/700
"STATUS" red "STATUS"紅燈	Narrow band 760 $\mu$ s Servo 窄頻760 $\mu$ s伺服器	Analog Servo As類比伺服器	Reverse rotation REV反轉	Right(Left) Travel limit 右(左)行程量	Mini/ Micro heli, suitable for T-REX250/450 小型/迷你型電直 適用T-REX 250/450
Setting instruction 設定方式說明	See no. 2 in setting instructions 參照設定方式第2項	See no. 3 in setting instructions 參照設定方式第3項	See no. 5 in setting instructions 參照設定方式第5項	See no. 6 in setting instructions 參照設定方式第6項	See no. 8 in setting instructions 參照設定方式第8項

NOTE: 1. "▲"Default setting. 2. Wrong heli mode will affect the performance of gyro. Do not fly before the complete setting.  
 註：1."▲"表出廠設定值。 2.錯誤的直昇機模式將影響陀螺儀性能，未完成設定前請勿飛行。

T-REX 600/700 Standard setting T-REX 600/700標準設定

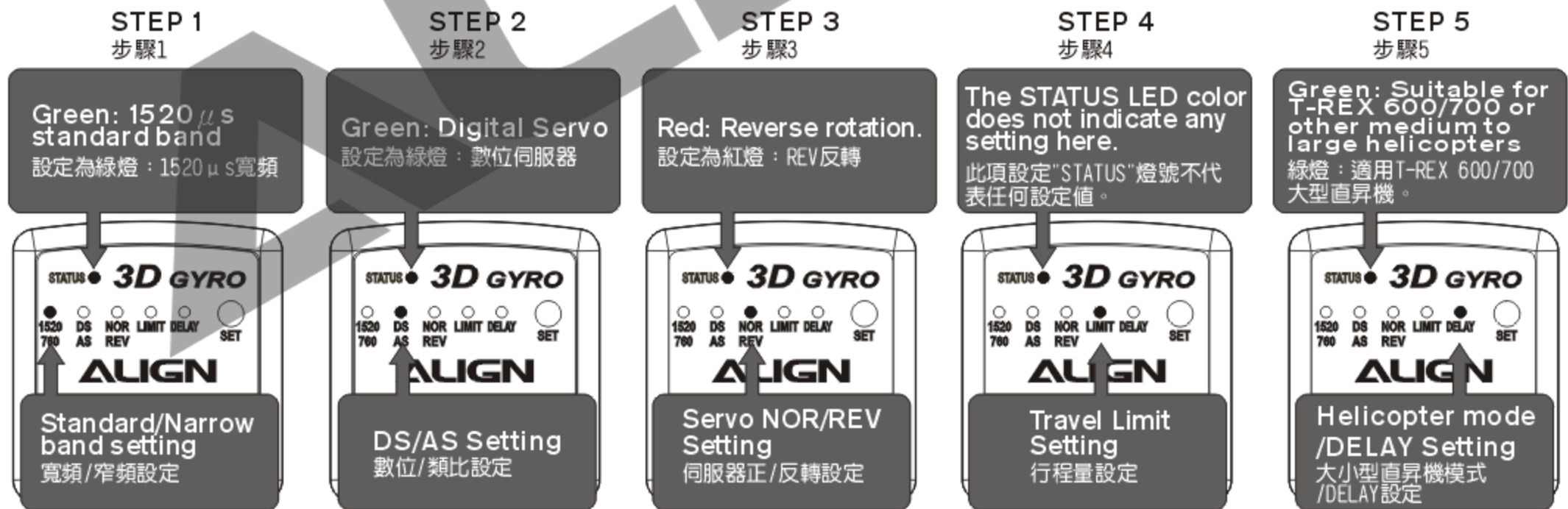
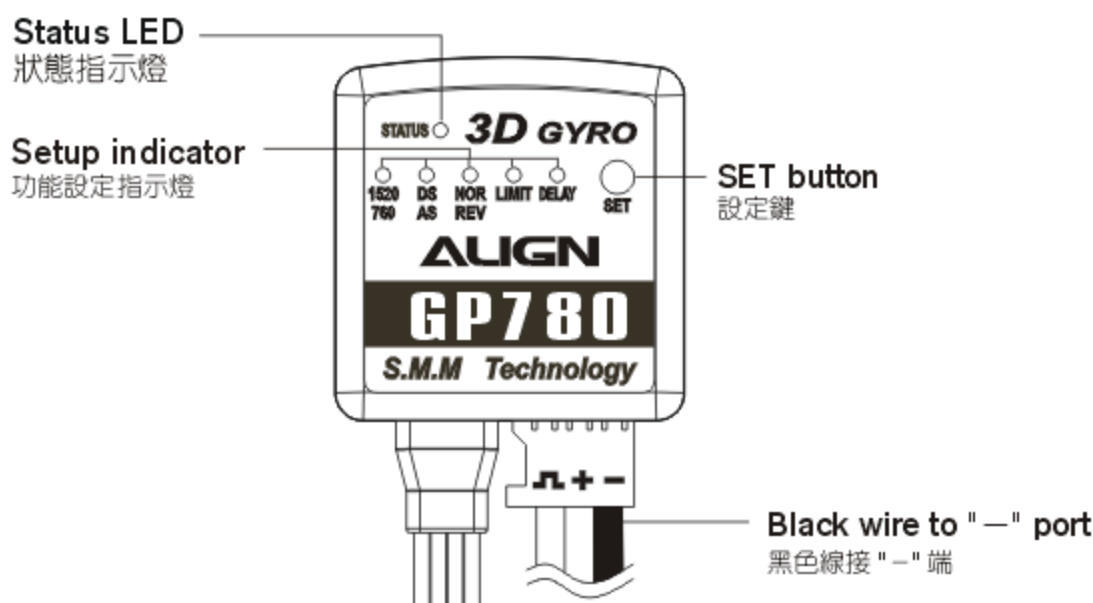

Diagram 各部名稱



GP780 Gyro Specifications GP780陀螺儀產品規格

- Operating Voltage: DC 4.5~7V
- Current Consumption: < 80mA @ 4.8V
- Angular Detection Speed:  $\pm$ 500 degrees/sec
- Operating Temperature: -20°C~ 65°C
- Operating Humidity: 0%~ 95%
- Size: 26x25x11mm
- Weight: 14g
- RoHS compliant
- 適用電壓: DC 4.5~7V
- 消耗電流: <80mA @4.8V
- 偵測角速度  $\pm$ 500度/sec
- 操作溫度: -20°C~65°C
- 操作濕度: 0%~95%
- 尺寸: 26x25x11mm
- 重量: 14g
- 符合RoHS限用規章

## DS620 Digital Servo DS620數位伺服器

- Speed: 0.09sec /60 degrees(4.8V)  
0.07sec /60 degrees(6.0V)
- Torque: 8.0kg.cm (4.8V)  
10.0kg.cm (6.0V)
- Dimension: 40.3 x 20.1 x 36mm
- Weight: 52.5g(Servo horn not included)
- 1520  $\mu$ s (standard band)
- 動作速度: 0.09sec/60° (4.8V)  
0.07sec/60° (6.0V)
- 輸出扭力: 8.0kg.cm(4.8V)  
10.0kg.cm(6.0V)
- 尺寸: 40.3x20.1x36mm
- 重量: 52.2g(不含舵角片)
- 1520  $\mu$ s(寬頻系統)

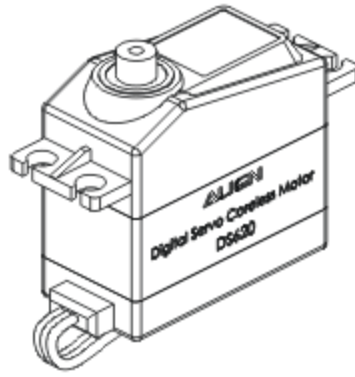

## Illustration 接線示意圖

Connects to gyro gain channel on receiver (CH5/AUX)  
接至接收機感度頻道 (CH5/AUX)

Connects to rudder channel on receiver (CH4/RUDD)  
接至接收機尾舵頻道 (CH4/RUDD)

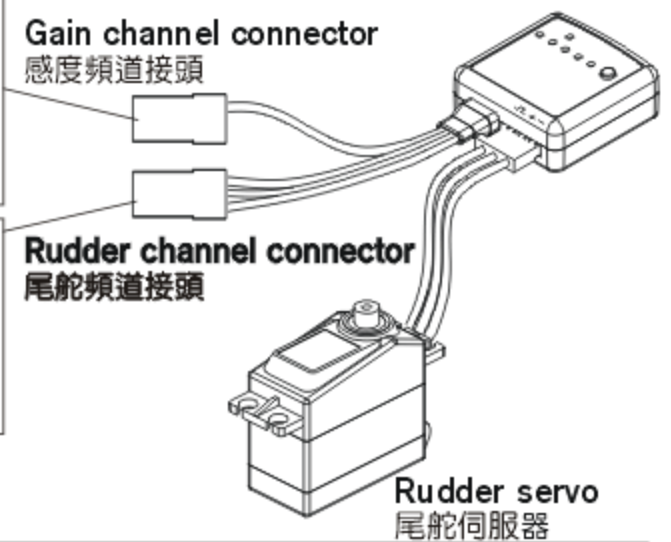

### Gain and Rudder channel mapping diagram 連接對照表:

Transmitter type 遙控器種類	Rudder channel on Receiver 尾舵頻道接頭至接收器	Gain channel on Receiver 感度頻道接頭至接收器
JR PPM/SPCM	"RUDD"	"AUX 2" or "AUX 3"
Hitec、Futaba PPM/PCM	"CH4"(RUD)	"CH5"
JR ZPCM	"RUDD"	"AUX 2"

### Gyro Installation 陀螺儀的安裝

- Utilizing the included double sided foam tape as shown in diagram beside, mount the gyro on a solid platform or designated gyro mounting location on the helicopter. Ensure gyro mounting area have proper ventilation and away from heat sources.
- To avoid drift induced by erroneous yaw detection, the bottom surface of gyro must be perpendicular (90 degrees) relative to the main shaft.
- For installation on electric powered helicopters, the gyro should be installed as far away from the electronic speed controller (ESC) as possible to avoid interference (minimum 5cm).

- 利用所提供的泡棉雙面膠如右圖方式, 把陀螺儀固定在穩定的平台上或機體預留的陀螺儀座, 並確保它在通風良好的區域, 遠離熱源。
- 陀螺儀底部水平貼附與直昇機的主軸呈垂直90度, 否則會影響感知器對角度變化的偵測, 造成偏移。
- 安裝於電動直昇機時盡量遠離(5公分以上)馬達與電子調速器, 避免干擾情形發生。

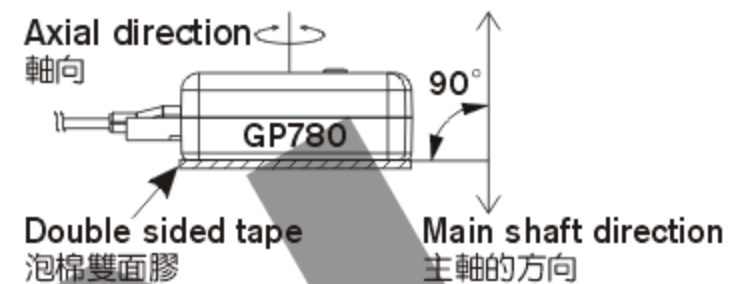

### Usage Setting Instructions 使用及設定方式

- Transmitter Settings:** After powering up transmitter, make sure rudder subtrim is zeroed. Then power on the receiver and gyro. The gyro will go through initializing process indicated by flashing LED from left to right. Do not touch the heli or transmitter sticks until initializing is complete, as indicated by a steady lit LED. A green LED indicates gyro is in AHTCS locking mode, while red LED indicates gyro is in normal mode.

**Note:** The GP780 is set to 1520  $\mu$ s at the factory. If 760  $\mu$ s servo is used in 1520  $\mu$ s mode, rudder servo will deflect to the side and unable to center. For more critically, the linkage rod may jam and cause the servo burned out. Please follow the instruction (Usage setting 2) to change the setting if 760  $\mu$ s servo is used.

Please ensure the following mixing functions (if available) are disabled or zeroed on the transmitter.

- ATS
- Rudder to gyro mixing
- Pilot authority mixing
- Pitch to rudder mixing
- Throttle to rudder mixing
- Revolution mixing

- 1520  $\mu$ s (standard) or 760  $\mu$ s (narrow band) servo selection:** GP780 offers compatibility for two types of frame rates under digital mode. Please set the GP780 to 760 mode if 760  $\mu$ s frame rate rudder servos (such as Futaba S9256, S9251, BLS251) are used. Most other servos have 1520  $\mu$ s frame rate, and GP780 should be set to 1520 mode if those servos are used.

**To enter the setup mode:** Press and hold the SET button for 2 seconds, and the STATUS LED will begin flashing. When the 1520/760 indicator lit up, you are in the servo frame rate setup menu. Use the rudder stick on your transmitter to select the frame rate: move the stick to left (or right) and STATUS led changes to green, the frame rate has been set to 1520  $\mu$ s. If you want to set the frame rate to 760  $\mu$ s, move the stick to opposite end 3 times to make STATUS led changes to red. (Note: The faceplate of GP780 has the setting values listed in the corresponding green/red letters.) Press the SET to confirm the current setting and enter the next setting. The GP780 will exit setting mode if left idle for 10 seconds.

- Digital (DS) / Analog (AS) Servo Selection:** Servo speed is of paramount importance in maximizing the gyro's performance. Fast servos are able to respond to gyro commands quickly, resulting in the speed and precision of overall system. Due to the high sensitivity of GP780 gyro, high speed digital servos such as Align DS650, DS620, DS520, DS420, Futaba S9257, S9256, S9254, S9253, or other similar spec servos are recommended. Select "DS" when digital servos are used, and "AS" when analog servos are used. **To enter the setup mode:** Press and hold the SET button for 2 seconds, and the STATUS LED will begin flashing. Press the SET button repeatedly until DS/AS led is lit. Use the rudder stick on your transmitter to select the Servo type: move the stick to left (or right) and STATUS led changes to green, the servo type is set to DS. Move the stick to opposite direction and STATUS led changes to red, the servo type is set to AS. **Warning:** The use of analog servo under "DS" mode will result in servo failure. The GP780 gyros are set to "DS" mode at the factory. Please set the proper servo type based on servo used.

- Check the direction of rudder:** move the rudder stick on transmitter left/right and check the helicopter's instruction manual for correct rudder direction. Servo reverse function on the transmitter can be used for reversed rudder. Set the transmitter gyro gain channel to normal mode, or press and hold the SET button for 2 seconds to center the rudder servo. Adjust the servo horn so it is perpendicular (90 degrees) relative to the pushrod. Then adjust the rudder linkage length so the tail pitch control system is within range. **Setting Method:** Press and hold the SET button for 2 seconds to enter the setup menu, and select DELAY setting. Push the rudder stick left or right and observe the STATUS LED. Red represents mini/micro helis, green represents medium/large helis. The amount of delay is set by holding the rudder stick at the position corresponding the delay percentage, 0% at middle stick position and 100% at the end position, and pressing the SET button to confirm the delay setting.

- 檢查遙控器的設定: 先開啟遙控器電源, 將尾舵的微調歸零後, 再開啟直昇機的接收機電源, 此時陀螺儀會先進入初始化狀態, 所有指示燈會由左至右閃爍, 接著使尾舵伺服器回到中立點, 在此之前請勿晃動直昇機或撥動尾舵搖桿, 當狀態指示燈為綠色時表示陀螺儀在鎖定的狀態, 指示燈為紅色時表示陀螺儀在非鎖定的狀態。

※註: GP780出廠時內建為 1520  $\mu$ s 系統, 若使用 760  $\mu$ s 窄頻伺服器時, 開機後尾伺服器將會偏向一邊無法置中, 甚至造成連桿卡死而使伺服器燒毀, 請參照使用及設定方式第2項更改設定值。  
如果您的遙控器有下列功能時, 請設定為關閉(OFF)或數值設定為零

- ATS
- Rudder to gyro mixing
- Pilot authority mixing
- Pitch to rudder mixing
- Throttle to rudder mixing
- Revolution mixing

- 1520  $\mu$ s (標準) 或 760  $\mu$ s (窄頻) 伺服器選擇:** GP780 相容兩種波寬控制系統, 若您使用的伺服器屬於 760  $\mu$ s 系統 (如 Futaba S9256、S9251、BLS251), 則必須將 GP780 設定於 760 的模式, 其他未標示 760  $\mu$ s 規格的伺服器, 一般皆為 1520  $\mu$ s 系統, 必須將 GP780 設定為 1520 的模式。  
**如何進入功能設定模式:** 持按面板上的 "SET" 設定鍵約 2 秒, 此時 "STATUS" 狀態指示燈會開始閃爍, 且 "1520/760" 的功能設定指示燈會亮起, 表示進入標準/窄頻伺服器選項, 利用遙控器方向舵搖桿的左右方向來選擇設定值, 例如方向舵搖桿往左 (或右) 時, "STATUS" 指示燈為綠色, 表示設定值為 1520  $\mu$ s 系統; 若要設定為窄頻 760  $\mu$ s 系統時, 必須將搖桿由中立點往相反方向連續撥動 3 次, 使 "STATUS" 指示燈亮紅色, 才會進入 760  $\mu$ s 系統。(註: GP780 的面板標籤上已使用綠/紅色的字體提示 "STATUS" 燈色所代表的設定值)。設定完成後按 "SET" 鍵一次可進入下一個設定, 或是 10 秒內不做任何設定, GP780 會自動離開設定模式。

- DS 數位 / AS 類比伺服器選擇:** 伺服器動作速度攸關陀螺儀的性能, 伺服器動作愈快, 就能立即反應陀螺儀送出的指令, 發揮快速精準的效能; 由於 GP780 具有相當快速的反應時間與靈敏度, 所以建議您搭配高速型數位伺服器, 如 ALIGN DS650、DS620、DS520、DS420、Futaba S9257、S9256、S9254、S9253 或其他相同規格伺服器, 以獲得最佳效能。設定方式: 持按 "SET" 鍵 2 秒進入功能設定模式, 再按 "SET" 鍵選擇 DS/AS 選項, (DS/AS 指示燈亮起), 利用舵搖桿選擇數位 DS (STATUS 為綠燈) 或類比 AS (STATUS 為紅燈) 伺服器。

注意: 在 DS 模式下連接 AS 類比伺服器將導致伺服器燒毀, 本產品出廠時設定在 DS 模式, 請自行依所搭配的伺服器類型選擇正確的模式。



4. 檢查尾舵伺服器正逆轉方向與調整連桿: 左右撥動尾舵搖桿, 確認尾舵伺服器移動的方向是否正確, 若不正确請更改遙控器上的尾舵伺服器正逆轉方向。將 GP780 切換成非鎖定模式或持按 GP780 的 "SET" 鍵 2 秒, 使尾舵伺服器保持在中立點的位置上, 調整伺服舵片, 儘可能使尾舵連桿與伺服擺臂呈 90 度, 接著調整連桿長度使尾 Pitch 控制組置中。

Utilizing DS620 rudder servo as an example, the recommended location of linkage connection is the second hole from the center on the servo horn. The ideal distance from linkage connection to servo center is 10mm.

以 DS620 尾舵伺服器為例, 建議將球頭鎖附於伺服舵片 由內算起的第二孔, 使尾舵控制桿與伺服機平行距離 10mm 左右為最佳。

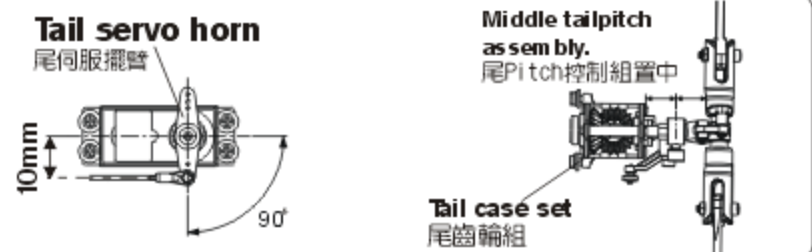

5. **Setting of gyro direction nor/rev:** Check the gyro direction by moving the heli on the yaw axis while holding by hand. Observe the direction gyro is moving the rudder servo. If direction is incorrect, switch the direction switch on the gyro to compensate. To enter the setup mode: Press and hold the SET button for 2 seconds, and the STATUS LED will begin flashing. Press the SET button repeatedly until NOR/REV led is lit. Use the rudder stick on your transmitter to select the Servo type: move the stick to left (or right) and STATUS led changes to green, the servo direction is set to NOR. Move the stick to opposite direction and STATUS led changes to red, the servo direction is set to REV. Warning: Flying with reversed gyro will cause the heli to spin out of control. Please double check the direction before attempting to fly the heli.
6. **Rudder Servo Travel Limit Adjustment:** Press and hold the SET button for 2 seconds until the STATUS LED flashes. At this point the rudder servo will be centered. Press the SET button repeatedly until LIMIT led is lit. While observing the heli tail, gradually move the rudder stick on your transmitter left until the tail pitch slider reaches its mechanical end (without binding), then center the rudder stick and wait 2 seconds until STATUS LED flashes red. Now perform the same for right rudder: move the rudder stick on your transmitter right until the tail pitch slider reaches the other end, center the stick and wait 2 seconds for LED to flash again. This will set the travel limit of the servo on both sides. Insufficient rudder servo travel limit will result in decreased rudder performance, while excessive rudder servo travel will overload the rudder servo and cause failures. Caution: Rudder travel setting can not be below 50%, or else GP780 will not register the settings. If excessive travel is observed even after performing the above rudder travel adjustments, please relocate the rudder servo linkage ball closer to the center of servo horn.
7. **Gyro Gain Adjustments:** For radio with GYRO function, gain can be adjusted using this function. The AHTCS (heading lock) gain is set by adjusting the GYRO setting between 50% to 100%, while the normal mode gain is set by adjusting the GYRO setting between 0 to 49%. Actual gain settings will differ amongst different helis and/or servo. The goal is to achieve as high of gain as possible without the tail oscillating (wagging), therefore such adjustment can only be done under actual flight conditions. Suggested initial settings are 70~80% during hover, and 60~70% during idle-up conditions. Gyro gain can be increased or decreased after observing the presence of tail oscillation during flights. Note: For radio systems using 0-100% as gain adjustment under heading lock mode (such as Futaba), the recommended gain setting is approximately 30~35%. For radio system using 50-100% as gain adjustment under heading lock mode (such as JR and Hitec), the recommended gain setting is approximately 70~75%.
8. **helicopter mode and delay setting. These settings incorporates two functions:**  
 (1) GP780 supports mini/micro indoor helicopters. Set the setting based on the appropriate helicopter class. For example: Set the helicopter mode to mini/micro setting (Status LED turns red) for T-Rex 250 and 450; set the helicopter mode to medium/large setting (Status LED turns green) for T-Rex 500/600/700.  
 (2) Slow rudder servos may cause tail oscillation as it receives the faster signal from gyro. If tail oscillation occurs after hard stop from stationary pirouette, increase the gain setting until such oscillation stops.
- Setting Method:** Press and hold the SET button for 2 seconds to enter the setup menu, and select DELAY setting. Push the rudder stick left or right and observe the STATUS LED. RED STATUS represents mini/micro helis such as T-REX 250/450, GREEN STATUS represents medium/large helis such as T-REX 500/600/700. The amount of delay is set by holding the rudder stick at the position corresponding the delay percentage, 0% at middle stick position (DELAY STATUS LED is flashing) and 100% at the end position, and pressing the SET button to confirm the delay setting.
5. NOR/REV 陀螺儀正逆轉開關設定: 提起直昇機, 將機頭往左擺動, 若尾舵伺服器的擺動方向與遙控器的方向舵搖桿打右舵同方向時, 表示陀螺儀的動作方向設定正確, 若不正确時請更改正逆轉設定。  
 設定方式: 持按 "SET" 鍵 2 秒進入功能設定模式, 選擇 NOR/REV 選項, 以方向舵選擇 NOR (STATUS 為綠燈) 或 REV (STATUS 為紅燈)。  
 注意: 陀螺儀的正逆轉方向設定錯誤時會造成直昇機高速自旋的危險, 請務必確認。
6. LIMIT 尾舵伺服器行程量調整: 持按 "SET" 鍵 2 秒進入功能設定模式, 此時尾舵伺服器會保持在中立點的位置上, 選擇 LIMIT 選項, 接著將方向舵搖桿慢慢的往左移動, 使尾控制組達到該側的最大行程限度後, 將搖桿回歸中立點不動, 待 2 秒後 "STATUS" 指示燈會亮紅燈閃爍, 表示左側行程量已記憶; 接著將尾舵搖桿向右移動至控制組最大行程限度後, 再將搖桿回歸中立點不動, 待 2 秒後 "STATUS" 指示燈亮紅燈閃爍, 即完成左右行程量設定, 行程量不足時會影響陀螺儀與直昇機的性能, 行程量過大易造成伺服器損壞。注意: 尾舵行程量設定不可低於 50%, 否則 GP780 將不予記憶, 若發生行程量設定後, 尾控制組仍會超過最大行程, 請將尾舵擺臂的球頭向內移動, 避免行程量不足影響陀螺儀性能。
7. 感度調整: 一般具有陀螺儀感度設定功能的遙控器, 可直接進入 GYRO 功能選項進行感度值的設定, 設定值 50% 則陀螺儀的感度為 0, 設定值 50%~100%, 則陀螺儀感度值為鎖定狀態的 0~100%; 設定值 50%~0%, 則陀螺儀感度值為非鎖定狀態的 0~100%。感度值的大小會隨著伺服器與直昇機的不同而有所差異, 一般而言, 在不產生追蹤現象 (直昇機尾部出現左右搖擺的情況) 的前提下感度值愈高愈好, 所以只能透過實際飛行的狀況來進行調整。進入遙控器感度設定的選項, 剛開始停懸時建議先設定在 70~80% 左右, Idle up 飛行時設定在 60~70% 左右, 之後再依實際飛行的狀態再行修正, 如果沒有追蹤現象發生時可再調整高感度, 若發生追蹤現象時, 則調低感度。  
 ※註: 鎖定感度值為 0~100% 的遙控器, 如 Futaba, 建議設定在 30~35% 左右; 鎖定感度值為 50~100% 的遙控器, 如 JR、HITEC、建議感度值設定在 70~75% 左右。
8. 直昇機模式與 DELAY 控制延遲量調整, 此設定結合兩項功能:  
 (1) GP780 支援小型/迷你型室內電直, 請依您直昇機的類型選擇適合的模式, 如: T-REX 250/450 請選擇小型/迷你型模式 (設定時 "STATUS" 指示燈為紅色); T-REX 500/600/700 請選中大型直昇機模式 (設定時 "STATUS" 指示燈為綠色)  
 (2) 使用速度較慢的尾舵伺服器較容易產生追蹤現象, 當直昇機停懸時, 打方向舵使直昇機快速自轉, 當方向舵回到中立點使直昇機停止自轉時, 此時若發生追蹤現象, 請增加控制延遲的設定量, 一般而言在不產生追蹤現象的原則下控制延遲的設定量愈小愈好, 否則尾舵的動作會變得遲緩。  
 設定方式: 持按 "SET" 鍵 2 秒進入功能設定模式, 選擇至 DELAY 選項, 以方向舵搖桿選擇小型/迷你型電直如 T-REX 250/450 (STATUS 為紅燈), 或中大型直昇機如 T-REX 500/600/700 (STATUS 為綠燈), 若要同時設定 DELAY 控制量時, 則利用方向舵搖桿的位置來設定, 搖桿由中立點推至 "DELAY" 燈開始閃爍時為 0%, 推至最大行程時控制量為 100%, 將搖桿推至所需的延遲量時保持不動, 並按下 "SET" 鍵確認, 即可同時設定直昇機模式與延遲量。

## 16. FLIGHT ADJUSTMENT AND SETTING 飛行動作調整與設定

ALIGN

Please practice simulation flight before real flying 飛行前請事先熟練電腦模擬飛行









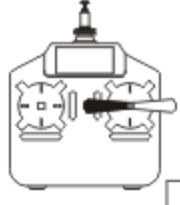
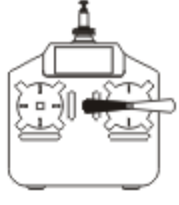

A safe and effective practice method is to use the transmitter flying on the computer through simulator software sold on the market. Do a simulation flight until you familiarize your fingers with the movements of the rudders, and keep practicing until the fingers move naturally.

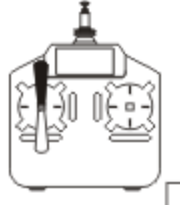
1. Place the helicopter in a clear open field ( Make sure the power OFF ) and the tail of helicopter point to yourself.
2. Practice to operate the throttle stick (as below illustration) and repeat practicing "Throttle high/low", "Aileron left/right", "Rudder left/right", and "Elevator up/down".
3. The simulation flight practice is very important, please keep practicing until the fingers move naturally when you hear operation orders being call out.

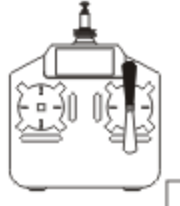

在還沒瞭解直昇機各動作的操控方式前, 嚴禁實機飛行, 請先進行電腦模擬飛行的練習, 一種最有效、最安全的練習方式, 就是透過市面販售的模擬軟體, 以遙控器在電腦上模擬飛行, 熟悉各種方向的操控, 並不斷的重複, 直到手指可熟練的控制各個動作及方向。

1. 將直昇機放在空曠的地方 (確認引擎為熄火狀態), 並將直昇機的機尾對準自己。
2. 練習操作遙控器的各搖桿 (各動作的操作方式如下圖), 並反覆練習油門高/低、副翼左/右、升降舵前/後及方向舵左/右操作方式。
3. 模擬飛行的練習相當重要, 請重複練習直到不需思索, 手指能自然隨著喊出的指令移動控制。

Mode 1	Mode 2	Illustration 圖示
 Aileron 副翼		 Move left 左移      Move right 右移 Rotate left 左翻      Rotate right 右翻
 Elevator 升降/前後		 Fly forward 前進      Fly backward 後退 Forward rotate 前翻      backward rotate 後翻
 Throttle 油門		 Ascent 上升 Descent 下降
 Rudder 方向		 Turn right 右旋 Turn left 左旋

**Flight adjustment and notice for beginners 初學飛行調整與注意**

★When arriving at the flying field.  
★當抵達飛行場



- Check if the screws are firmly tightened.
- Check if the transmitter and receivers are fully charged.
- 再次確認→螺絲是否鎖固?
- 發射器和接收器電池是否足夠。



If there are other radio control aircraft at the field, make sure to check their frequencies and tell them what frequency you are using. Frequency interference can cause your model, or other models to crash and increase the risk of danger.  
假使飛行場有其他遙控飛機，請確認他們的頻率，並告知他們你正在使用的頻率，相同的頻率會造成干擾導致失控和大大地增加風險。



**Engine start preparation 引擎啟動事前準備**

Separate the fuel tube and the joint and start to refuel. Please be careful to avoid the dust entering the tube. When the fuel tank is full, please stop refueling and reconnect the tube and the joint.  
將油管與其接頭分離，並開始補給燃料。請小心避免灰塵砂粒進入管子內。當油箱已滿，請停止補給燃料並再將管子和接頭接合。

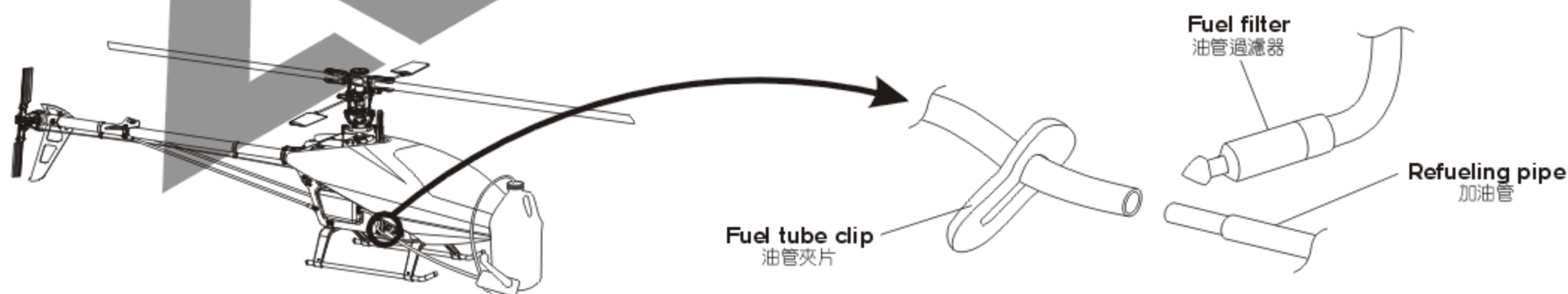

First check to make sure no one else is operating on the same frequency. Then place the throttle stick at lowest position and turn on the transmitter.

首先確認附近沒有其他相同頻率的使用，然後打開發射器將油門搖桿推到低點。

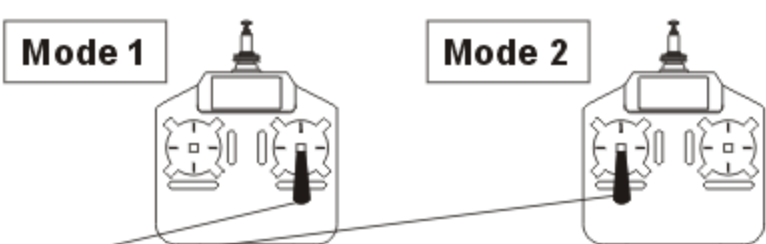

Check if the throttle stick is set at the lowest position and check if engine throttle is at low speed.  
確認油門搖桿是在最低的位置，並確認引擎油門置於低速。

**Needle valve adjusting suggestion 引擎油針調整建議**

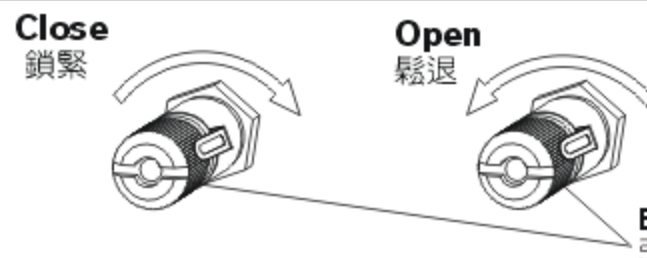

For a new engine, recommend closing the needle valve completely first, and then open the needle valve 1.5 turns for running-in during the first 3 flights. After the first 3 flights, see the flight conditions to adjust the engine to higher speed, recommend closing the needle valve to 1.25 turns. (Please refer to the original instruction manual of the engine for more detail.)  
建議新引擎於前3次飛行時主油針先鎖緊後，以鬆退1 1/2圈條件引擎磨合飛行。3次飛行以後，可視飛行狀況適當調高引擎轉速，建議可調緊主油針到1 1/4圈。(詳細調整請參閱原廠說明書)

If the engine speed and the temperature are too high, it will seriously affect the engine life.  
引擎轉速、溫度過高將嚴重影響引擎壽命。



## Glow plug ignition method 火星塞點火方式

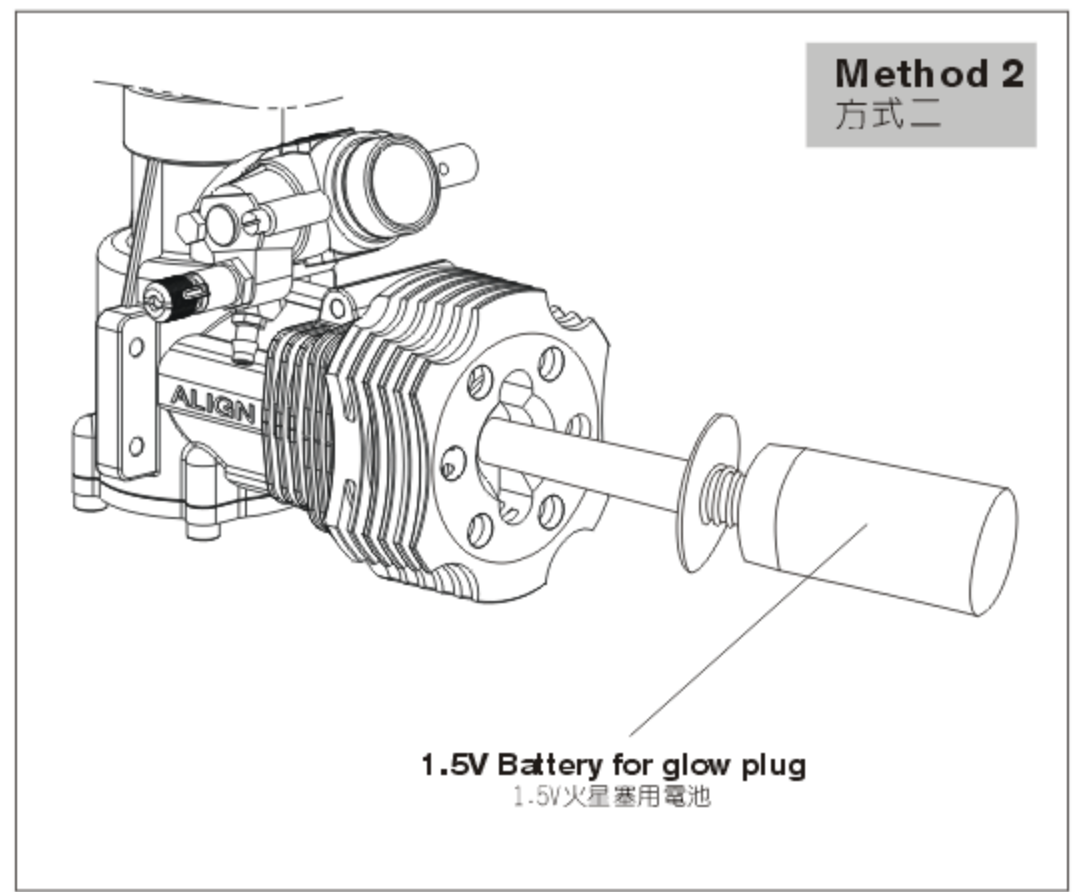
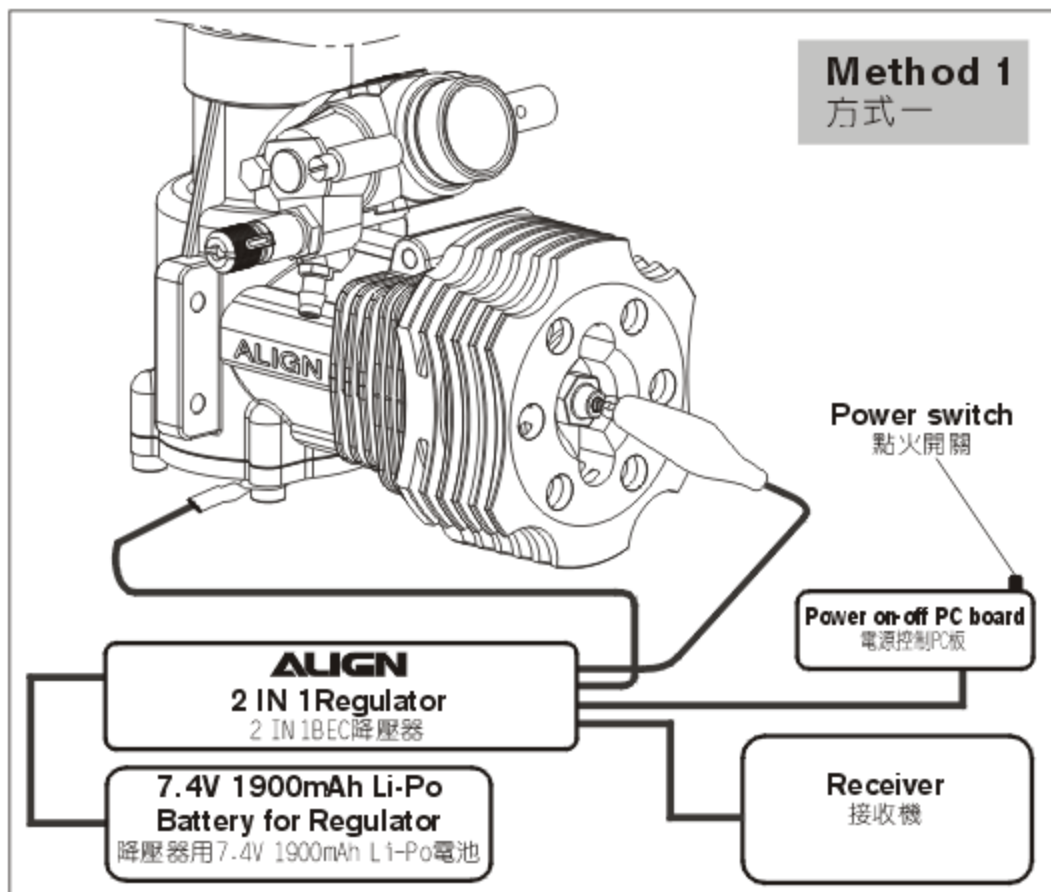

## Engine start and stop 引擎啟動和熄火

1. Connect the battery to the starter and check the rotation direction. Insert the starter shaft into the starter completely.
2. Tightly hold the main rotor head, and insert the starter shaft into the starter coupling. Then turn the starter to start the engine.
3. When the engine starts, stop the starter and remove it from the starter coupling. Please keep holding the main rotor head tightly.
4. Hold the main rotor head tightly, and turn off the power of glow plug or remove the power.
5. Still hold the main rotor head tightly, turn throttle trim at the lowest position, and keeping engine in lowest regular running.
6. If you want to stop the engine, please set the throttle trim (beside the throttle stick) at the lowest position. If the engine cannot stop, please put the Fuel Clip into lock position to stopping refueling.

1. 將啟動電池連接到啟動器並確認其轉動方向。將啟動軸完全插入啟動器。
2. 緊緊抓住主旋翼頭部，將啟動軸插入引擎啟動頭並以啟動器啟動引擎。
3. 當引擎啟動後，停止啟動器並將啟動頭上的啟動器移開。請保持繼續緊緊抓住主旋翼頭部。
4. 仍然緊緊抓住主旋翼頭部，將火星塞點火電池關閉或移開。
5. 仍然緊緊抓住主旋翼頭部，請保持油門於最低點時，引擎能保持於低怠速下正常運轉。
6. 欲將引擎熄火時，只需將油門搖桿旁的油門微調調至最低即可；如果引擎仍無法停止，請將油管夾片推至鎖定位置，關閉油料供給。

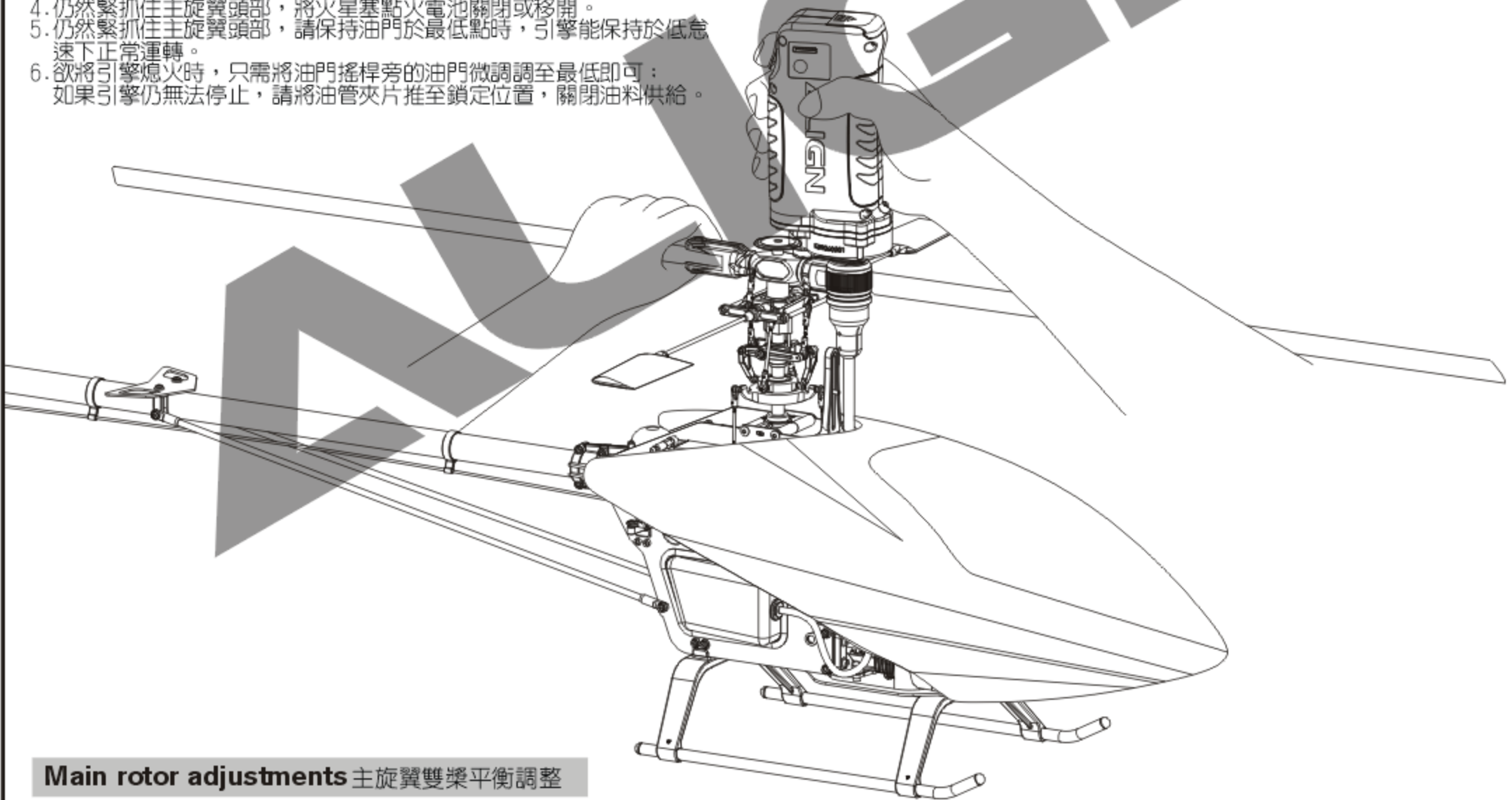

## Main rotor adjustments 主旋翼雙槳平衡調整



**Tracking adjustment is very dangerous, so please keep away from the helicopter at a distance of at least 10m.**  
調整軌跡非常危險，請於距離飛機最少10公尺的距離。

1. Before adjusting, apply a red piece of tape on one blade, or paint a red stripe with a marker or paint to identify on blade.
  2. Raise the throttle stick slowly and stop just before the helicopter lifts-off ground. Look at the spinning blades from the side of the helicopter.
  3. Look at the path of the rotor carefully. If the two blades rotate in the same path, it does not need to adjustment. If one blade is higher or lower than the other blade, adjust the tracking immediately.
  4. Linkage rod (A): Regular pitch trim (For large variations). Linkage rod (C): Slight pitch trim (For slight variations).
1. 調整前先在其中一支主旋翼的翼端，貼上有顏色的貼紙或畫上顏色記號，方便雙槳調整辨識。
  2. 慢慢的推起油門搖桿到高點並且停止，在飛機離開地面前，從飛機側邊觀察主旋翼轉動。
  3. 仔細觀察旋翼軌跡（假如兩支旋翼移動都是相同軌跡，則不需要調整；可是如果一支旋翼較高或較低產生“雙槳”的情形時，則必須立刻調整軌跡）。
  4. 連桿(A)為一般螺距調整（雙槳翼大時使用）。連桿(C)為螺距微調調整（雙槳微幅差異時使用）。
- A. When rotating, the blade with higher path means the pitch too big. Please lengthen pitch linkage rod (A) for regular trim or shorten linkage rod (C) for slight pitch trim.**
- B. When rotating, the blade with lower path means the pitch too small. Please shorten pitch linkage rod (A) for regular trim or lengthen linkage rod (C) for slight pitch trim.**

- A. 旋翼轉動時較高軌跡的主旋翼表示螺距 (PITCH) 過大, 請調長連桿 (A) 修正, 或需要更小的螺距微調時, 請調短連桿 (C) 修正。  
 B. 旋翼轉動時較低軌跡的主旋翼表示螺距 (PITCH) 過小, 請調短連桿 (A) 修正, 或需要更小的螺距微調時, 請調長連桿 (C) 修正。



**Incorrect tracking may cause vibrations. Please repeat adjusting the tracking to make sure the rotor is correctly aligned. After tracking adjustment, please check the pitch angle is approx. 5° when hovering.**

不正確的旋翼軌跡會導致震動, 請不斷重複調整軌跡, 使旋翼軌跡精準正確。  
 在調整軌跡後, 確認一下 Pitch 角度在停旋時應為大約 5°。



**FLIGHT ADJUSTMENT AND NOTICE FOR BEGINNERS 初學飛行調整與注意**



- ◎ Make sure that no one or obstructions in the vicinity.
- ◎ You must first practice hovering for flying safety. This is a basic flight action. (Hovering means keeping the helicopter in mid air in a fixed position)
- ◎ 確認鄰近地區沒有人和障礙物。
- ◎ 為了飛行安全, 你必須先練習停旋, 這是飛行動作的基礎 (停旋: 直昇機滯留空中並保持固定位置)。

- ◎ Please stand approximately 10m diagonally behind the helicopter.
- ◎ 練習時, 請站在直昇機後方 10 公尺。

Beginner may install a training landing gear to avoid any crash caused by offset effect while landing.  
 必要時初學者可以在腳架下方安裝練習架, 可避免降落時因重心偏移導致主旋翼或直昇機損毀。



**STEP 1 THROTTLE CONTROL PRACTICE 油門控制練習**

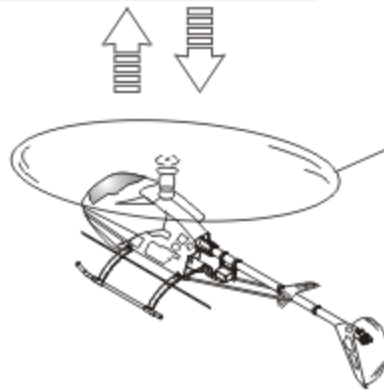
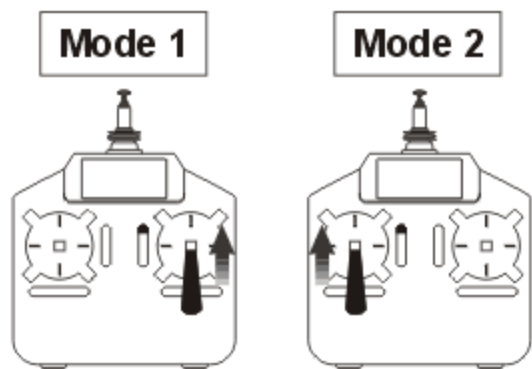

- ◎ When the helicopter begins to lift-off the ground, slowly reduce the throttle to bring the helicopter back down. Keep practicing this action until you control the throttle smoothly.

◎ 當直昇機開始離地時, 慢慢降低油門將飛機降下。持續練習飛機從地面上升和下降直到你覺得油門控制很順。

**STEP 1 THROTTLE CONTROL PRACTICE 油門控制練習**

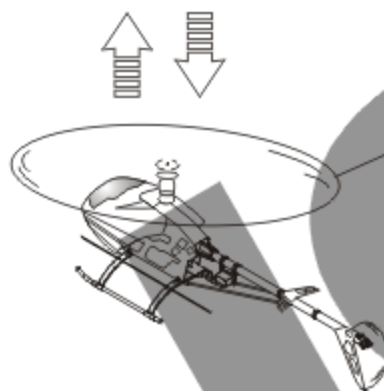
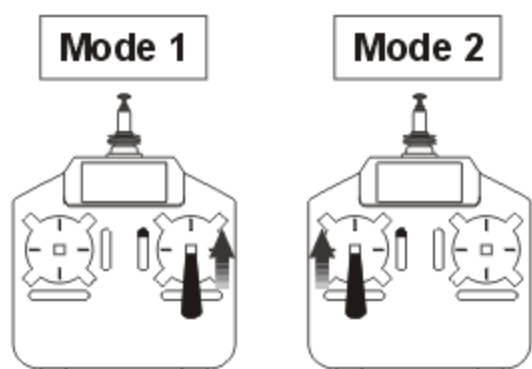

- ◎ When the helicopter begins to lift-off the ground, slowly reduce the throttle to bring the helicopter back down. Keep practicing this action until you control the throttle smoothly.

◎ 當直昇機開始離地時, 慢慢降低油門將飛機降下。持續練習飛機從地面上升和下降直到你覺得油門控制很順。

**STEP 2 AILERON AND ELEVATOR CONTROL PRACTICE 副翼和升降控制練習**

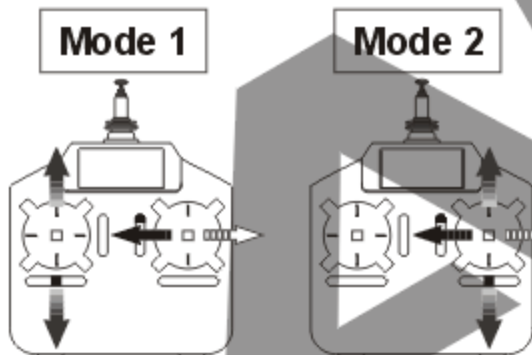

1. Raise the throttle stick slowly.
  2. Move the helicopter in any direction back, forward, left and right, slowly move the aileron and elevator sticks in the opposite direction to fly back to its original position.
1. 慢慢升起油門搖桿。  
 2. 使直昇機依指示: 移動向後/向前/向左/向右, 慢慢的反向移動副翼和升降搖桿並將直昇機開回到原來位置。

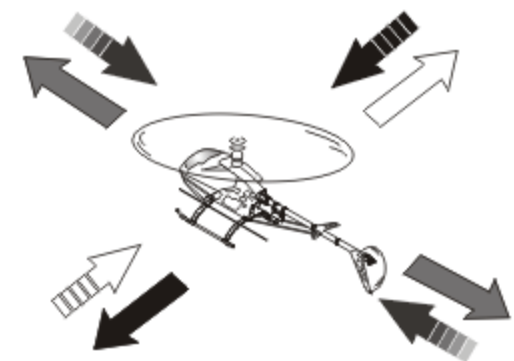

- ◎ If the nose of the helicopter moves, please lower the throttle stick and land the helicopter. Then move your position diagonally behind the helicopter 10m and continue practicing.
- ◎ If the helicopter flies too far away from you, please land the helicopter and move your position behind 10m and continue practicing.
- ◎ 當直昇機機頭偏移時, 請降低油門並且降落, 然後移動自己的位置到直昇機的正後方 10 公尺再繼續練習。
- ◎ 假如直昇機飛離你太遠, 請先降落直昇機, 並到直昇機後 10 公尺再繼續練習。

**STEP 3 RUDDER CONTROL PRACTICING 方向舵操作練習**

1. Slowly raise the throttle stick.
  2. Move the nose of the helicopter to right or left, and then slowly move the rudder stick in the opposite direction to fly back to its original position.
1. 慢慢升起油門搖桿。  
 2. 將直昇機機頭移動左或右, 然後慢慢反向移動方向舵搖桿並將直昇機飛回原本位置。

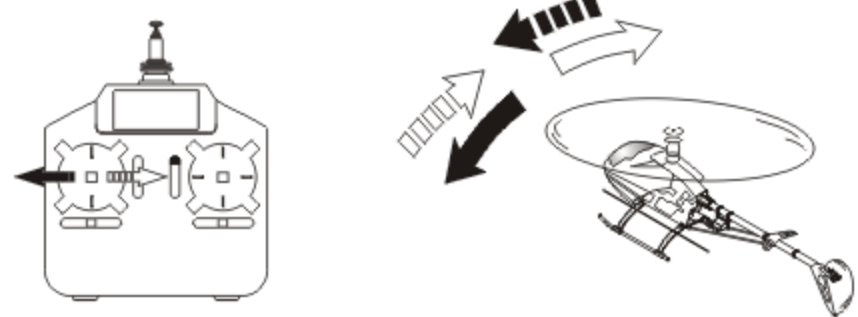

**STEP 4**

After you are familiar with all actions from Step 1 to 3, draw a circle on the ground and practice within the circle to increase your accuracy.

當你覺得 step 1-3 動作熟悉了, 在地上畫圈圈並在這個圈圈的範圍內練習飛行, 以增加你操控的準確度。

- ◎ You can draw a smaller circle when you get more familiar with the actions.
- ◎ 當你更加習慣操作動作, 你可以畫更小的圈圈。

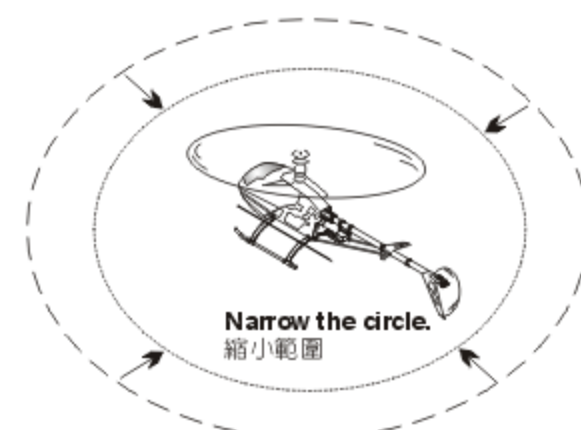

**STEP 5 DIRECTION CHANGE AND HOVERING PRACTICE 改變直昇機方向和練習停旋**

After you are familiar with Step1 to 4, stand at side of the helicopter and continue practicing Step1 to 4.

Then repeat the Step1 to 4 by standing right in front of the helicopter.

當你覺得step1-4動作熟悉了，站在面對直昇機側邊並繼續練習step1-4。之後，站在直昇機機頭右邊重複步驟練習。

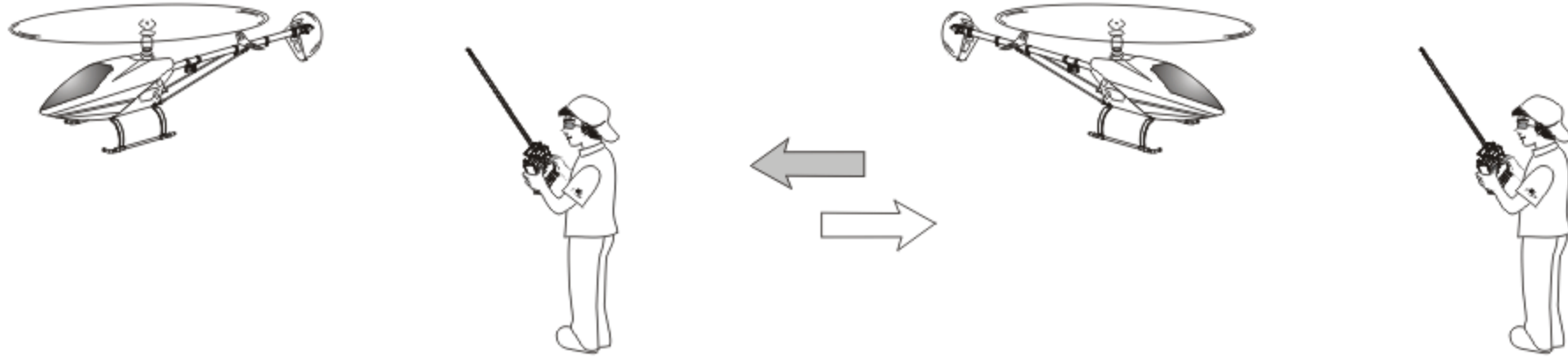

**ADJUSTMENT OF EACH TRIM 飛行動作微調**

Slowly raise the throttle stick and just as the helicopter lift-off the ground, you can use the trim to correct the action if the helicopter leans in a different direction.

慢慢升起油門搖桿，當直昇機剛剛離開地面時，若直昇機傾向不同方向，可使用微調修正動作。

**1. Adjustment of rudder trim 調整方向舵微調**  
 Just before the helicopter lift-off, the nose lean left/right...  
 When leans right, adjust the trim to left side.  
 When leans left, adjust the trim to right side.

在直昇機正要起飛時，機頭朝左/右方向偏移...  
 向右偏移時，微調向左調整。  
 向左偏移時，微調向右調整。

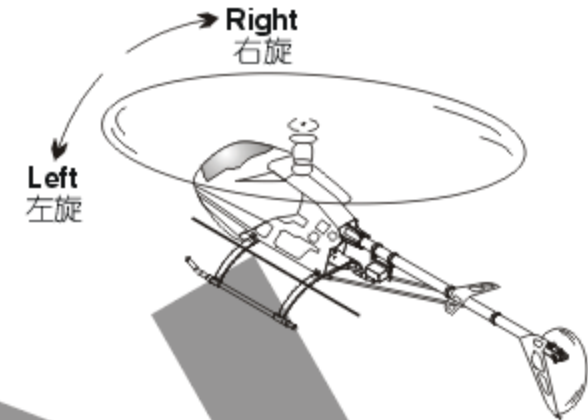
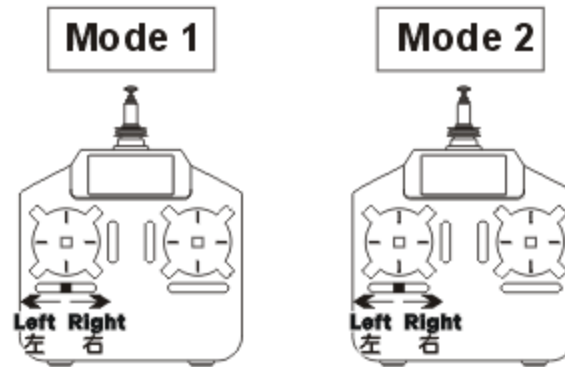

**2. Adjustment of elevator trim 調整升降舵微調**

Just before the helicopter lift-off, the nose lean forward/backward...  
 When leans forward, adjust the trim down.  
 When leans backward, adjust the trim up.

在直昇機正要起飛時，機頭朝前/後方向偏移...  
 向前偏移時，微調向下調整。  
 向後偏移時，微調向上調整。

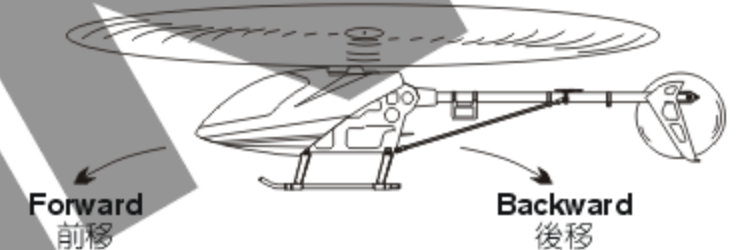
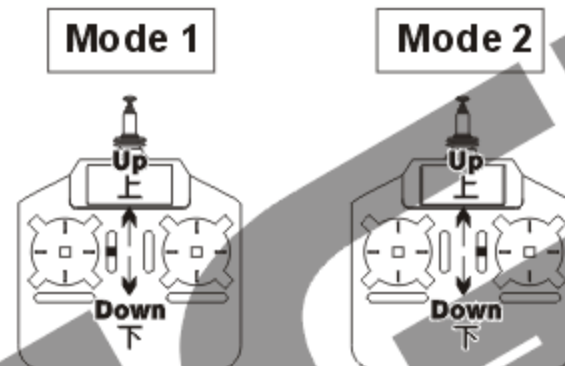

**3. Adjustment of Aileron trim 調整副翼微調**

Just before the helicopter lift-off, the body lean left/right...  
 When leans right, adjust the trim to left side.  
 When leans left, adjust the trim to right side.

在直昇機正要起飛時，機身朝左/右方向偏移...  
 向右偏移時，微調向左調整。  
 向左偏移時，微調向右調整。

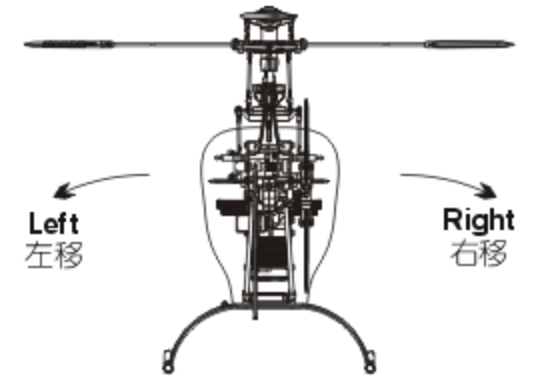
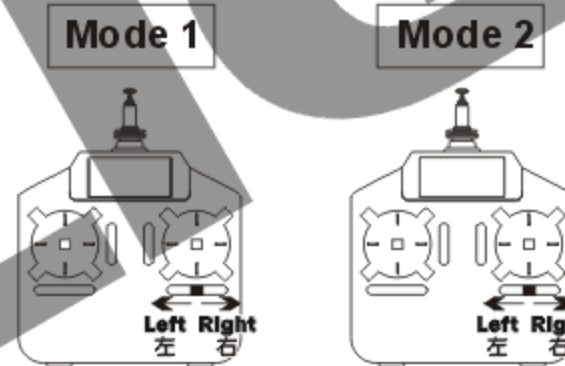

**TROUBLE SHOOTING DURING FLIGHT 如何排除飛行中的狀況**

	Situation 狀況	Cause 原因	Way to deal 對策
<b>Blade Tracking 雙槳平衡</b>	Out of tracking 雙槳	Adjustment of pitch rod has not been done. PITCH連桿長度調整不平均	Adjust the length of linkage rod(A) → Regular trim Adjust the length of linkage rod(C) → Slight trim 調整連桿(A)長度 → 一般調整 調整連桿(C)長度 → 微調整
<b>During Hovering 停旋</b>	Low rotation of the rotor 主旋翼轉速偏低	★ Pitch of main blade is high. ★ 主旋翼的PITCH偏高 ★ Throttle curve is too low during hovering. ★ 停旋點油門曲線過低	★ Lower the pitch about 4~5 during hovering(The rotation should be about 1,600rpm during hovering). ★ 調低Pitch停旋Pitch約4-5 (停旋時主旋翼需為約1600RPM) ★ Heighten the throttle curve during hovering. ★ 調高停旋點油門曲線
	High rotation of the rotor 主旋翼轉速偏高	★ Pitch of main blade is low. ★ 主旋翼的PITCH偏低 ★ Throttle curve is too high during hovering. ★ 停旋點油門曲線過高	★ Adjust the pitch rod <A> (The rotation should be about 1,600rpm during hovering). ★ 調整連桿 <A> (停旋時主旋翼需為約1600RPM) ★ Lower the throttle curve during hovering. ★ 調低停旋點油門曲線
<b>Sensitivity of the gyro 陀螺儀敏感度</b>	The tail leans to one side during hovering, or when trim the rudder and return to the neutral, the tail lags and cannot stay in a control position. 停旋時尾翼向某一邊偏移，或撥動方向舵並回復到中立點時，尾翼產生延遲，無法停頓在所控制位置上。	★ Failure setting of tail neutral point. ★ 尾中立點設定不當 ★ The sensitivity of the gyro is low. ★ 陀螺儀敏感度偏低	★ Reset tail neutral point. ★ 重設尾中立點 ★ Increase the sensitivity. ★ 增加敏感度
	The tail wags left and right during flight at hovering or full speed. 停懸或全油門時尾翼左右來回快速搖擺。	The sensitivity of the gyro is high. 陀螺儀敏感度偏高	Decrease the sensitivity. 降低敏感度

※If the problem is still there even after tried above, stop flying and contact with your seller.

※在做完以上調整後，仍然無法改善情況時，應立即停止飛行並連絡您的經銷商。

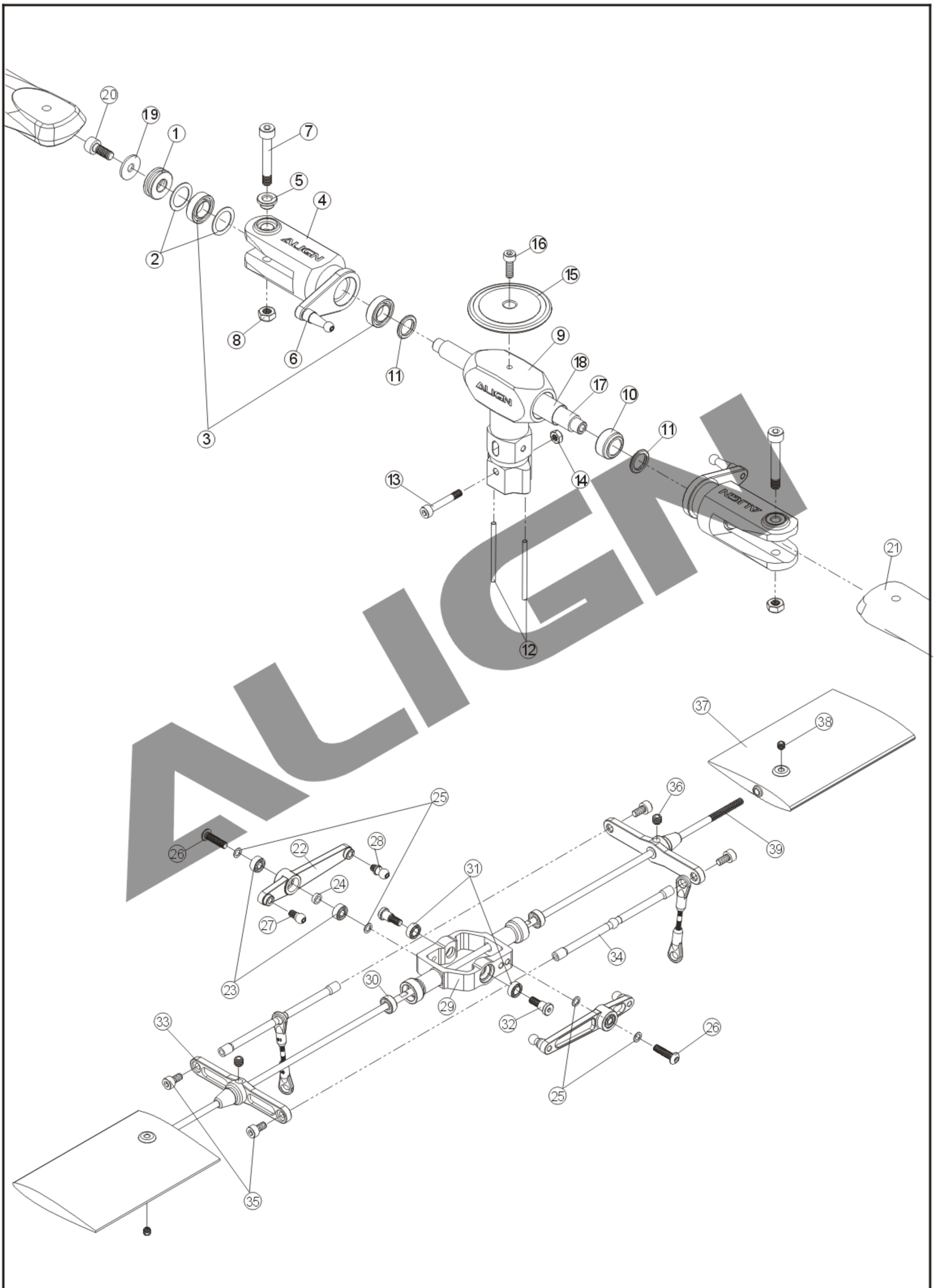

No.	Code No.	Name	Specification	Quantity	Remarks
1	50H009	Thrust bearing 止推軸承	φ 6x φ 14x5mm	2	
2	50H008-1	Spindle bearing spacer 橫軸軸承墊片	φ 10x φ 13.8x0.4mm	4	
3	50HMR148ZZ	Bearing 軸承	φ 8x φ 14x4mm	4	
4	50NH007	Metal main rotor holder 金屬主旋翼夾座		2	
5	50H011	Collar 金屬主旋翼夾座襯套	φ 4x φ 6x φ 9x4.3mm	2	
6	50NH006	Linkage ball F(M3.5x4) 球頭F (M3.5x4)	φ 4.75x20.25mm	2	
7	T64027	Socket collar screw 圓頭內六角軸套螺絲	M4x27mm	2	
8	N14001	M4 Nut M4防鬆螺帽	M4	2	
9	50H001A	Metal main rotor housing 金屬主旋翼固定座		1	
10	50NH008	Damper rubber-black 85° 橫軸墊圈-黑85°	φ 7.9x φ 13x6.5mm	2	
10-1	50NH013	Damper rubber-gray 70° 橫軸墊圈-灰70°	φ 7.9x φ 13x6.5mm	2	
11	50H006	Spacer 橫軸套圈	φ 8x φ 11.5x1.3mm	2	
12	50H136	Pin 定位插銷	φ 2x32mm	2	
13	T63022	Socket collar screw 圓頭內六角軸套螺絲	M3x22mm	1	
14	N10030	M3 Nut M3防鬆螺帽	M3	1	
15	50H164-1	Metal head stopper 金屬旋翼頭制動器		1	
16	T63010	Socket screw 圓頭內六角螺絲	M3x10mm	1	
17	50H003-2	Feathering shaft 橫軸	φ 6x φ 8x93.2mm	1	
18	50NH003	Feathering shaft sleeve 橫軸支撐套	φ 8x φ 10x31mm	1	
19	50H010	Washer 橫軸華司	φ 4x φ 12x1mm	2	
20	T64010	Socket screw 圓頭內六角螺絲	M4x10mm	2	
21	KU110025	600D Carbon Fiber Blades 600D碳纖主旋翼	600mm	1 set	
22	50H162-2	Metal SF Mixing arm 金屬SF控制搖臂		2	
23	50H683ZZ	Bearing 軸承	φ 3x φ 7x3mm	4	
24	50H024	Collar 擺臂軸承襯套	φ 3x φ 4.8x1.5mm	2	
25	50H022-2	Washer 華司	φ 3x φ 4.8x0.3mm	4	
26	T53012-1	Socket button head screw 半圓頭內六角螺絲	M3x12mm	2	
27	50H042-1	Linkage ball A(M3x4) 球頭A (M3x4)	φ 4.75x8.68mm	2	
28	50H044	Linkage ball B(M3x3) 球頭B (M3x3)	φ 4.75x9.77mm	2	
29	50H019-1	Metal flybar seesaw holder 金屬平衡桿固定座		1	
30	50TMR83ZZ	Bearing 軸承	φ 3x φ 8x3mm	2	
31	50HMR74ZZ	Bearing 軸承	φ 4x φ 7x2.5mm	2	
32	50H119-2	M3 collar screw M3雙層軸套螺絲	M3x9.6mm	2	
33	50NH002A	Metal flybar control arm 金屬平衡翼控制臂	φ 3.4x74.2mm	2	
34	50H018-1	Flybar control rod 平衡翼球型控制球桿		2	
35	T63005	Socket screw 圓頭內六角螺絲	M3x5mm	4	
36	T74004	M4 Set screw M4止洩螺絲	M4x4mm	2	
37	50NH011	Carbon fiber flybar paddle/3K 碳纖平衡翼/3K		1 set	
38	T73004	M3 Set screw M3止洩螺絲	M3x3mm	4	
39	50H033	Flybar rod 平衡翼桿	φ 3x440mm	1	

**Specifications, contents of parts and availability are subject to change, Align RC is not responsible for inadvertent errors in this publications.**  
 本說明書內的材質、規格或零件包裝之內容物僅供參考。本公司將不對此印刷物之異動負責，也無法主動通知消費者，任何更新或異動，請以亞拓網頁為主。

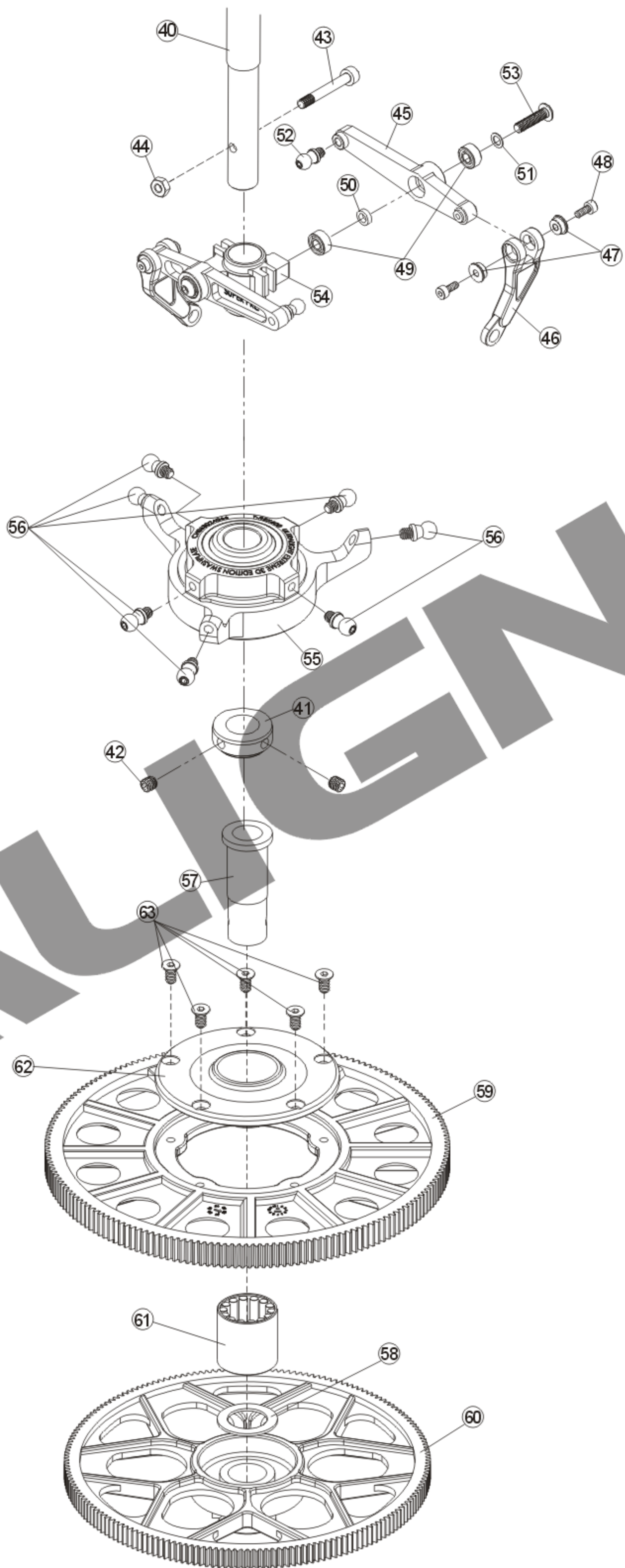



No.	Code No.	Name	Specification	Quantity	Remarks
40	50H047	Main shaft 主軸	φ 10x201x29.3mm	1	
41	50H045-1	Lock collar 主軸固定環	φ 10x φ 15x7mm	1	
42	T74004	M4 Set screw M4止洩螺絲	M4x4mm	2	
43	T63020	Socket collar screw 圓頭內六角軸套螺絲	M3x20mm	1	
44	N10030	M3 Nut M3防鬆螺帽	M3	1	
45	50H161-2	Metal washout control arm 金屬穩定控制搖臂		2	
46	50H218	Radius arm 新Radius連桿		2	
47	HFMR52ZZ-1	Bearing 軸承	φ 2x φ 5x2.3mm	4	
48	T52005	Socket screw 圓頭內六角螺絲	M2x5mm	4	
49	50H683ZZ	Bearing 軸承	φ 3x φ 7x3mm	4	
50	50H024	Collar 擺臂軸承襯套	φ 3x φ 4.8x1.5mm	2	
51	50H022-2	Washer 華司	φ 3x φ 4.8x0.3mm	2	
52	50H044	Linkage ball B(M3x3) 球頭B(M3x3)	φ 4.75x9.77mm	2	
53	T53012-1	Socket button head screw 半圓頭內六角螺絲	M3x12mm	2	
54	50NH004	Metal washout base 金屬向位器		1	
55		CCPM Metal Swashplate 金屬CCPM十字盤組		1	
56	50H044	Linkage ball B(M3x3) 球頭B(M3x3)	φ 4.75x9.77mm	7	
57	50B048-3	One-way bearing shaft 單向軸承套	φ 9x φ 12x34.55mm	1	
58	50B050	Washer 單向軸承華司	φ 11.5x φ 18x0.8mm	1	
59	50B158-1	Main drive gear(170T) 主齒盤(170T)	170T	1	
60	50B054-1	Autrotation tail drive gear(180T) 尾驅動主齒(180T)	180T	1	
61	50B049-1	One-way bearing 單向軸承	φ 12x φ 18x16mm	1	
62	50B051-3	Main gear case 主齒中心座	φ 55x14.5mm	1	
63	S83007	Hex socket self tapping screw 圓頭內六角自攻螺絲	T3x7mm	5	
227	50NB054	Fuel filter 油管過濾器	3-Way	1	Option parts
228	50NB045	Fuel filter 油管過濾器	2-Way	1	Option parts
229	50NB043	Fuel tube clip A 油管夾片A	26x9.8x3mm	1	
230	50NB044	Fuel tube clip B 油管夾片B	33.5x9.8x3mm	1	
231	50NB046	Fuel tube 油管	φ 2.5x φ 5x1000mm	1	
232	50H137-2	Main blade holder 主旋翼固定架泡棉	165x90x15mm	1	
233	K10378	Hook and Loop Tape 魔術帶	15x250mm	2	
234	K10379	Hook and Loop Tape 魔術帶	10x200mm	3	
235	K10365	Hook and Loop Tape 魔術沾	54x28mm	3	

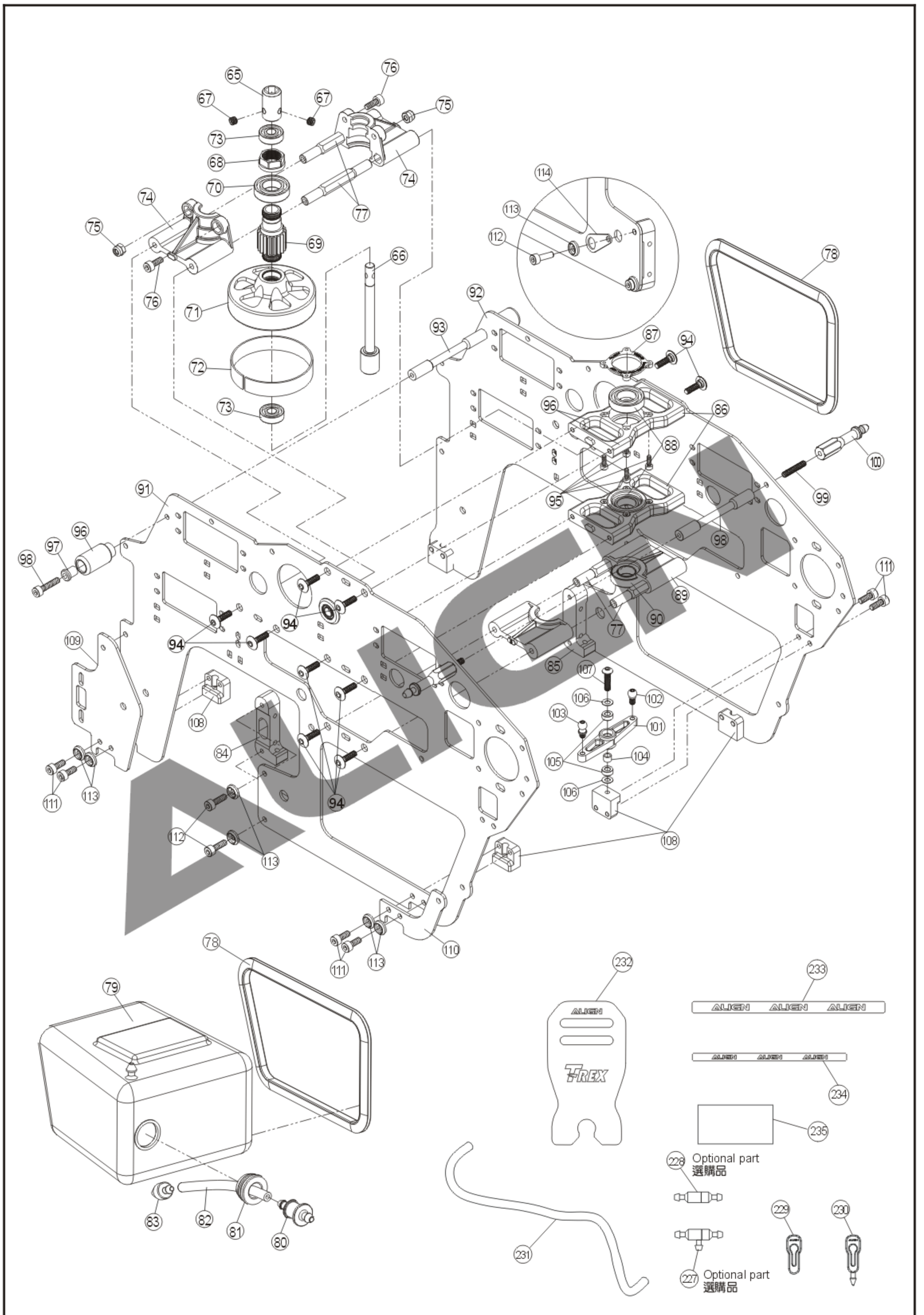

No.	Code No.	Name	Specification	Quantity	Remarks
65	50NB010	Starter coupling 六角啓動頭	φ 8x φ 10x18mm	1	
66	50NB009	Clutch/Start shaft 啓動軸	φ 7.5x φ 10x70.5mm	1	
67	T74004	M4 Set screw M4止洩螺絲	M4x4mm	2	
68	50NB007	Clutch nut 離合器齒輪螺帽	φ 14x6mm	2	
69	50NB011	Clutch gear 離合器齒輪	φ 15.4x φ 7x31.5mm	1	
70	50B6800ZZ-2	Bearing 軸承	φ 10x φ 19x5mm	1	
71	50NB006	Clutch bell 離合器輪	φ44x φ 47x20mm	1	
72	50NB033	Clutch liner 離合器來令片	0.8x8.75x136mm	1	
73	50NB695ZZ	Bearing 軸承	φ 5x φ 13x4mm	1	
74	50NB008	Clutch bearing block 離合器軸承座		2	
75	N10030	M3 Nut M3防鬆螺帽	M3	2	
76	T63008	Socket screw 圓頭內六角螺絲	M3x8mm	2	
77	50NB035	Hex mounting bolt 六角鋁柱	φ 5x49mm	2	
78	50NB031	Fuel tank guard 油箱墊圈		2	
79	50NB023-1	Pellucid fuel tank 透明油箱		1	
80	50NB026	Fuel tank nipple 油箱接頭		1	
81	50NB030	Grommet 油箱接頭墊圈	φ 8.4x φ 16.8x9mm	1	
82	50NB041	Fuel tube 油管	φ 2.5x φ 4x70mm	1	
83	50NB027	Fuel tank sinker 油管接頭		1	
84	50NB020-1	Engine mount (L) 引擎座(左)	39.3x16x8.5mm	1	
85	50NB021-1	Engine mount (R) 引擎座(右)	39.3x16x8.5mm	1	
86	50NB067	Metal bearing block 600N金屬主軸固定座		2	
87	50NB066-1	Metal main shaft clamp ring 600N金屬主軸固定蓋		2	
88	50B6800ZZ-2	Bearing 軸承	φ 10x φ 19x5mm	2	
89	50NB004	Lower bearig black(Mark B) 主軸下固定座(亥B)		2	
90	50B689ZZ-1	Bearing 軸承	φ 9x φ 17x5mm	1	
91	50NB005-2	Main frame(L) 碳纖主體左側板		1	
92	50NB005-2	Main frame(R) 碳纖主體右側板		1	
93	50NB025	Frame mounting bolt 機身鋁柱		2	
94	T53008-3	Socket button head collar screw 半圓頭內六角軸套螺絲	M3x8mm	16	
95	T62006	Socket screw 圓頭內六角螺絲	M2x6mm	8	
96	50NB039	Canopy spacer 機頭罩支撐墊圈	φ 4.8x φ 11x22mm	2	
97	50NB038	Canopy support 機頭罩支撐柱	φ 3x φ 5x φ 6.5x7.3mm	2	
98	T53014-2	Socket screw 圓頭內六角螺絲	M3x14mm	2	
99	T73015	M3 Set screw M3止洩螺絲	M3x15mm	2	
100	50NB064	Metal canopy mounting bolt 600N金屬機頭罩固定柱	7x37.75mm	2	
101	50NB053	Metal tail control arm 金屬尾控制臂		1	
102	50H042-1	Linkage ball A(M3x4) 球頭A (M3x4)	φ 4.75x8.68mm	1	
103	50H044	Linkage ball B(M3x3) 球頭B (M3x3)	φ 4.75x9.77mm	1	
104	50NB034	Collar 尾控制臂鋁套	φ 3x φ 4.4x3mm	1	
105	HMR63ZZ	Bearing 軸承	φ 3x φ 6x2.5mm	2	
106	50H022-2	Washer 華司	φ 3x φ 4.8x0.3mm	2	
107	T53012-1	Socket button head screw 半圓頭內六角螺絲	M3x12mm	1	
108	50NB019	Frame mounting block 機身固定塊	14x12.5x8mm	5	
109	50NB071A	Front frame brace(CF) 碳纖機身前補強片	81.09x37.36x1.6mm	2	
110	50NB071B	Rear frame brace(CF) 碳纖機身後補強片	40.71x50.7x1.6mm	2	
111	T63008	Socket screw 圓頭內六角螺絲	M3x8mm	10	
112	T63010	Socket screw 圓頭內六角螺絲	M3x10mm	4	
113	50B072	M3 Specialty washer M3特殊華司	φ 3x φ 8x2mm	14	
114	50NB032	Glow plug plate 火星塞點火器接地板	23.73x0.8mm	1	

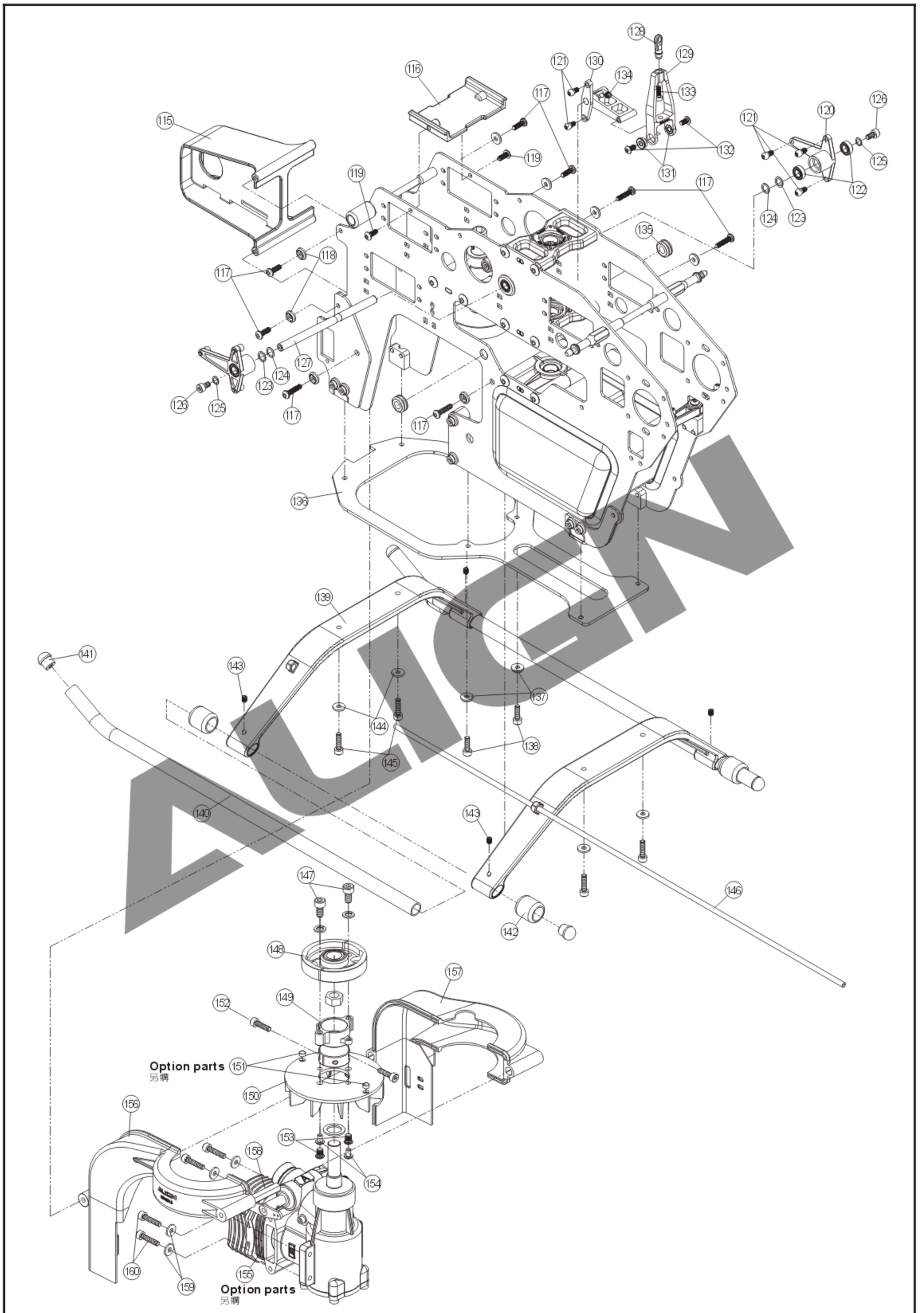

No.	Code No.	Name	Specification	Quantity	Remarks
115	50NB017	Receiver mount 接收器座	90x64x50mm	1	
116	50NB040-1	Gyro mount 陀螺儀固定座		1	
117	S93010	Socket button head self tapping screw 半圓頭內六角自攻螺絲	T3x10mm	8	
118	50B072	M3 Specialty washer M3特殊華司	φ 3x φ 8x2mm	8	
119	S93008	Socket button head self tapping screw 半圓頭內六角自攻螺絲	T3x8mm	2	
120	50NB016-1A	Metal aileron lever 金屬左右控制搖臂		2	
121	50H042-1	Linkage ball A(M3x4) 球頭A(M3x4)	φ 4.75x8.68mm	8	
122	50BMR95ZZ	Bearing 軸承	φ 5x φ 9x3mm	4	
123	50H022	Washer 華司	φ 5x φ 7x0.5mm	2	
124	50B058	Washer 華司	φ 5x φ 7x0.2mm	2	
125	50B059	Washer 華司	φ 3x φ 5.5x0.3mm	2	
126	T63006	Socket screw 圓頭內六角螺絲	M3x6mm	2	
127	50NB092	Control shaft 連動桿	φ 5x88mm	1	
128	50B238	Elevator ball link 升降控制連桿頭		1	
129	50B236	Elevator arm 升降控制臂		1	
130	50B237	Elevator lever 升降連動控制臂		1	
131	HF683ZZ	Bearing 軸承	φ 3x φ 7x3mm	2	
132	T53006	Socket button head screw 半圓頭內六角螺絲	M3x6mm	2	
133	T62508	Socket screw 圓頭內六角螺絲	M2.5x8mm	1	
134	T74004	M4 Set screw M4止洩螺絲	M4x4mm	1	
135	50NB037	Fuel line grommet 油管保護套	φ 5.2x φ 7x φ 11x4.8mm	2	
136	50NB022	CF Bottom bracket 碳纖底板	2mm	1	
137	W10030	Washer 華司	φ 3x φ 8x1mm	2	
138	T63010	Socket screw 圓頭內六角螺絲	M3x10mm	2	
139	50F179	Landing skid 腳架	300x60.25mm	2	
140	50F083	Skid pipe 腳架鋁管	φ 7x310mm	2	
141	50F084	Skid pipe end cap 腳架鋁管保護套		4	
142	50F130	Landing skid nut 腳架墊圈		4	
143	T73004	M3 Set screw M3止洩螺絲	M3x4mm	4	
144	W10030	Washer 華司	φ 3x φ 8x1mm	4	
145	T63012	Socket screw 圓頭內六角螺絲	M3x12mm	4	
146	50F128	Antenna pipe 天線管	φ 2x φ 3.9x500mm	1	
147	T64008-1	Socket head spring screw 圓頭內六角彈簧螺絲	M4x8mm	2	
148	50NB016-1	Clutch 離合器	φ 35x φ 42x12mm	1	
149	50NB012-3	Engine fan mount 引擎風扇座	φ 9x19.97x26mm	1	
150	50NB013-1	Engine fan 引擎風葉	φ 60x φ 26x2mm	1	
151		Magnet(Governor sensor) 定速感應磁鐵		2	Option parts
152	T63012	Socket screw 圓頭內六角螺絲	M3x12mm	2	
153	T54005	Socket button head screw 半圓頭內六角螺絲	M4x5mm	2	
154	T53005-1	Socket button head screw 半圓頭內六角螺絲	M3x5mm	2	
155	HE50H01	ALIGN 50 Engine ALIGN 50引擎		1	Option parts
156	50NB015	Engine fan cover(L) 引擎風扇蓋(左)	123x100x30mm	1	
157	50NB014	Engine fan cover(R) 引擎風扇蓋(右)	123x100x30mm	1	
158	50NB029	Hexagonal bolt 六角柱		2	
159	W10030	Washer 華司	φ 3x φ 8x1mm	4	
160	T53014-2	Socket screw 圓頭內六角螺絲	M3x14mm	4	

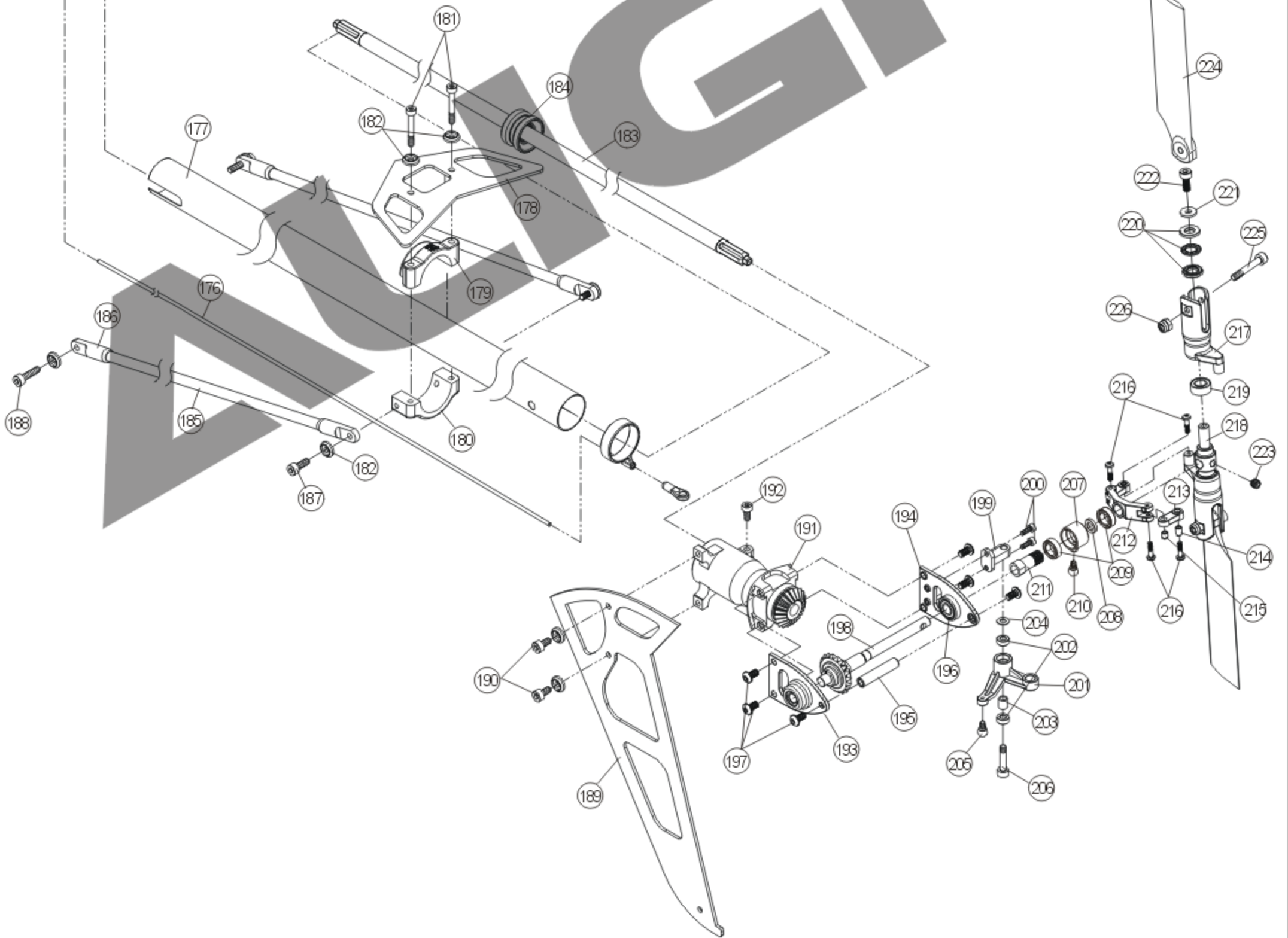
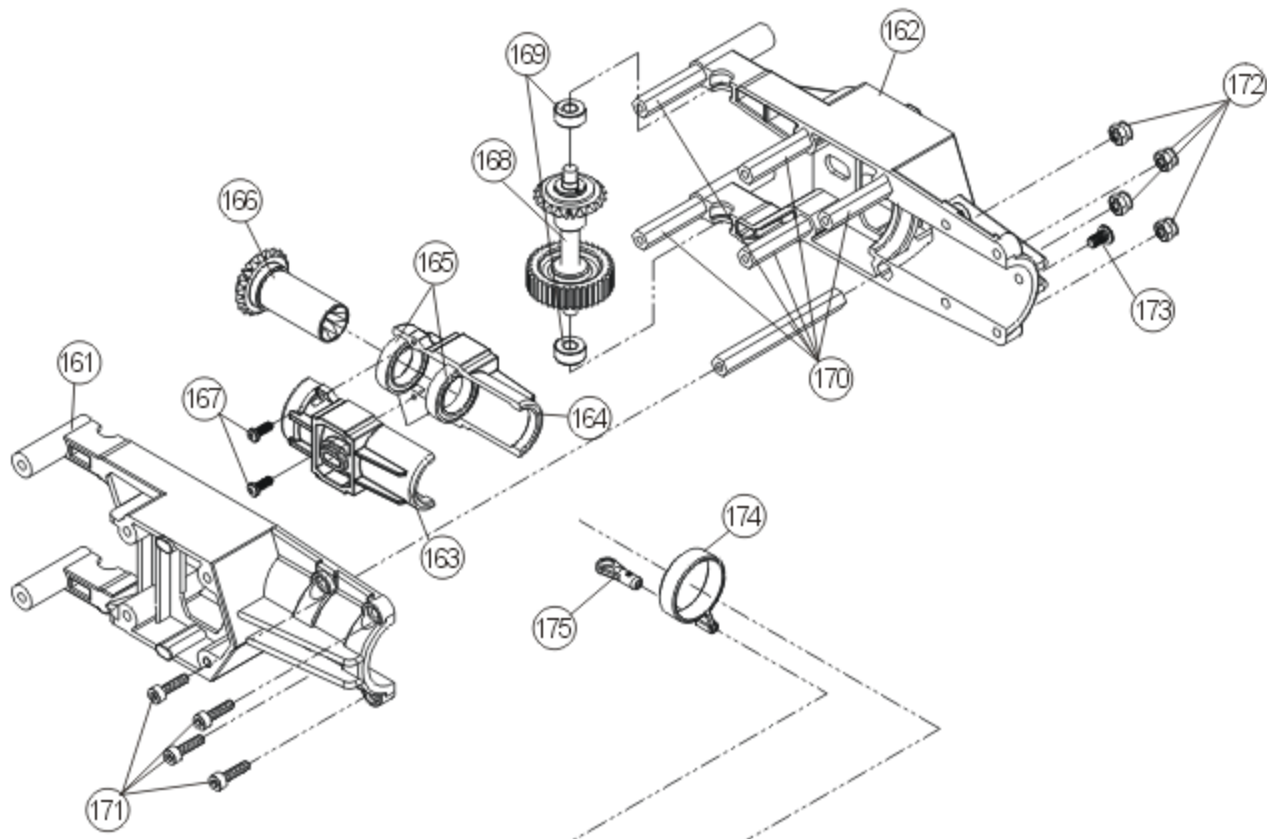

No.	Code No.	Name	Specification	Quantity	Remarks
161	50NB001	Tail boom mount (L) 尾管固定座(左)		1	
162	50NB002-1	Tail boom mount (R) 尾管固定座(右)		1	
163	50T199	Umbrella gear case (L) 傘齒左固定座		1	
164	50T200	Umbrella gear case (R) 傘齒右固定座		1	
165	50T6701ZZ	Bearing 軸承	φ 12x φ 18x4mm	2	
166	50T194	Front umbrella gear 前軸傳傘型齒	φ 21.2x33.6mm	1	
167	T52008-1	Socket button head screw 半圓頭內六角螺絲	M2x8mm	2	
168		Front drive gear assembly 尾傳動導輪軸組		1	
169	50B684ZZ	Bearing 軸承	φ 4x φ 9x4mm	2	
170	50NB029	Hexagonal bolt 六角柱		6	
171	T63012	Socket screw 圓頭內六角螺絲	M3x12mm	4	
172	N10030	M3 Nut M3防鬆螺帽	M3	4	
173	T53005-1	Socket button head screw 半圓頭內六角螺絲	M3x5mm	1	
174	50T125-1	Tail control guide 尾控制桿固定環		2	
175	50Z124	Ball link 連桿頭		2	
176	50NT002-1	Tail rudder control rod B 尾舵控制連桿B	φ 1.97x657mm	1	
177	50NT012-2	Tail boom 尾管	φ 20.3x φ 21.5x625mm	1	
178	50T167-1	3K CF Horizontal stabilizer 3K碳纖水平翼		1	
179	90NT025	Metal stabilizer mount (Upper) 金屬水平翼固定座(上)		1	
180	50T108-2	Metal stabilizer mount (Lower) 金屬水平翼固定座(下)		1	
181	T63022	Socket collar screw 圓頭內六角軸套螺絲	M3x22m	2	
182	50B072	M3 Specialty washer M3特殊華司	φ 3x φ 8x2mm	8	
183		Torque tube set 尾傳動軸桿組		1	
184	50T193	Torque tube bearing holder 尾傳動軸承墊圈		1	
185	50T132	Tail boom brace 尾管支撐桿	φ 5x460mm	2	
186	50T123	Tail boom brace end 尾支撐架接頭		4	
187	T63008	Socket screw 圓頭內六角螺絲	M3x8mm	2	
188	T63012	Socket screw 圓頭內六角螺絲	M3x12mm	2	
189	50T166-2	3K CF Vertical stabilizer 3K碳纖垂直翼		1	
190	T63010	Socket screw 圓頭內六角螺絲	M3x10mm	2	
191		Metal tail unit set 金屬尾軸傳固定座組		1	
192	T63008	Socket screw 圓頭內六角螺絲	M3x8mm	1	
193	50T182	Metal plate (L) 金屬尾軸傳左側板	39.5x25x9.3mm	1	
194	50T183	Metal plate (R) 金屬尾軸傳右側板	39.5x25x9.3mm	1	
195	50T192	Aluminum bolt 金屬尾軸箱鋁柱	φ 4.98x24mm	1	
196	50TMR105ZZ	Bearing 軸承	φ 5x φ 10x4mm	2	
197	T53006	Socket button head screw 半圓頭內六角螺絲	M3x6mm	6	
198		Tail rotor shaft assembly 尾橫軸組		1	
199	50T185	Control arm mounting bolt 軸傳尾控制臂固定座		1	
200	T52005	Socket screw 圓頭內六角螺絲	M2x5mm	2	
201	50T096-1	Tail rotor control arm 尾旋翼控制臂		1	
202	HMR63ZZ	Bearing 軸承	φ 3x φ 6x2.5mm	2	
203	50T097	Collar 尾旋翼控制臂鋁套	φ 3x φ 4.9x5mm	1	
204	50H022-2	Washer 華司	φ 3x φ 4.8x0.3mm	1	
205	50H144-1	Linkage ball A(T2.6x3.5) 球頭A(T2.6x3.5)	φ 4.75x8.18mm	1	
206	T63015	Socket collar screw 圓頭內六角軸套螺絲	M3x15mm	1	
207	50T102-2	Bearing holder 尾控制組軸承套座		1	
208	50T114	Collar 尾控制組軸套鋁襯墊		1	
209	50T106ZZ	Bearing 軸承	φ 6x φ 10x3mm	2	
210	50H144-1	Linkage ball A(T2.6x3.5) 球頭A(T2.6x3.5)	φ 4.75x8.18mm	1	
211	50T101-2	Slide Shaft 尾軸滑套	φ 5x φ 7.2x16.7mm	1	
212	50T111	T type arm 尾翼控制組T型臂		1	
213	50T105-1	Control link 尾控制連桿頭		2	
214	50T106	Collar A 尾連桿頭銅套A	φ 2x φ 3x4mm	2	
215	50T127	Collar B 尾連桿頭銅套B	φ 2x φ 3x3mm	2	
216	T12008-4	Collar screw 軸套螺絲	M2x8mm	4	
217	50NT013	Metal tail rotor holder 金屬尾旋翼夾座		2	
218	50T172	Tail rotor hub 尾旋翼T型座	φ 10x39.6mm	1	
219	50TMR105ZZ-1	Bearing 軸承	φ 5x φ 10x4mm	2	
220	50TF510M	Thrust bearing 止推軸承	φ 5x φ 10x4mm	2	
221	W10030-1	Washer 華司	φ 3x φ 8x0.6mm	2	
222	T63008	Socket screw 圓頭內六角螺絲	M3x8mm	2	
223	T74004	M4 Set screw M4止洩螺絲	M4x4mm	1	
224	50T203	3K CF Tail blade 3K碳纖尾旋翼		2	
225	T63016	Socket collar screw 圓頭內六角軸套螺絲	M3x16mm	2	
226	N10030	M3 Nut M3防鬆螺帽	M3	2	



### Specifications & Equipment/規格配備:

Length/機身長: 1160mm

Height/機身高: 410mm

Main Blade Length/主旋翼長: 600mm

Main Rotor Diameter/主旋翼直徑: 1350mm

Tail Rotor Diameter/尾旋翼直徑: 240mm

Motor Pinion Gear/引擎主齒: 20T

Autorotation Tail Drive Gear/尾驅動主齒: 180T

Drive Gear Ratio/齒輪傳動比: 8.5:1:4.5 (E:M:T)

Flying Weight/全配重: Approx. 3.2kg

