

Super Combo T-REX 550E V2

ALIGN

INSTRUCTION MANUAL

使用說明書

KX021008T

3GX

Compact



Contents	
1	INTRODUCTION 前言
1~2	SAFETY NOTES 安全注意事項
3	EQUIPMENT REQUIRED FOR ASSEMBLY 自備設備
3	PACKAGE ILLUSTRATION 包裝說明
4	SAFETY CHECK BEFORE FLYING 飛行前安全檢查
5~14	ASSEMBLY SECTION 組裝說明
15	BRUSHLESS SPEED CONTROLLER INSTALLATION SUGGESTION ESC無刷調速器安裝建議位置
16	3GX FLYBARLESS SYSTEM INSTALLATION 3GX無平衡翼系統安裝
16	CANOPY ASSEMBLY 機頭罩安裝
17	ELECTRIC EQUIPMENT ILLUSTRATION 電子設備建議配置圖示
18	SERVO AND LINKAGE ROD SETTING ILLUSTRATION 伺服器設定與調整
18	ADJUSTMENTS FOR GYRO AND TAIL NEUTRAL SETTING 陀螺儀與尾翼中立點調整
19	PITCH AND THROTTLE SETTING 主旋翼螺距與油門設定
20~29	3GX FLYBARLESS FL760 MANUAL 無平衡翼系統使用說明
29	RCM-BL600MX 1220KV POWER COLLOCATION REFERENCE 原裝動力數據參考表
30~32	RCE-BL70G BRUSHLESS SPEED CONTROLLER INSTRUCTION MANUAL 無刷調速器使用說明
33~34	3GX FLYBARLESS FLIGHT TEST PROCEDURE 飛行前測試程序
34~37	FLIGHT ADJUSTMENT AND SETTING 飛行動作調整與設定
38	3GX FLYBARLESS PREFLIGHT CHECK 飛行測試程序
38	SETUP EXAMPLES 飛行特性設定對照表
39	TROUBLESHOOTING 飛行中狀況排除
40	Q & A 問與答

3Axis MEMS i2bit S.BUS Easy Energy Stable GOV 250-700 280Hz 3.5V-6.0V RoHS

Thank you for buying ALIGN products. The T-REX 550E V2 3GX is the latest technology in Rotary RC models. Please read this manual carefully before assembling and flying the new T-REX 550E V2 3GX helicopter. We recommend that you keep this manual for future reference regarding tuning and maintenance.

承蒙閣下選用亞拓遙控世界系列產品，謹表謝意。進入遙控世界之前必須告訴您許多相關的知識與注意事項，以確保您能夠在學習的過程中較得心應手。在開始操作之前，請務必詳閱本說明書，相信一定能夠給您帶來相當大的幫助，也請您妥善保管這本說明書，以作為日後參考。

Thank you for buying ALIGN Products. The T-REX 550E V2 3GX Helicopter is designed as an easy to use, full featured Helicopter R/C model capable of all forms of rotary flight. Please read the manual carefully before assembling the model, and follow all precautions and recommendations located within the manual. Be sure to retain the manual for future reference, routine maintenance, and tuning.

The T-REX 550E V2 3GX is a new product developed by ALIGN. It provides flying stability for beginners, full aerobatic capability for advanced fliers, and unsurpassed reliability for customer support.

感謝您選購亞拓產品，為了讓您容易方便的使用 T-REX 550E V2 3GX 直昇機，請您詳細的閱讀完這本說明書之後再進行組裝以及操作這台直昇機，同時請您妥善的保存這本說明書，作為日後進行調整以及維修的參考。

T-REX 550E V2 3GX 是由亞拓自行研發的新產品，不論你是需求飛行穩定性的初學者或是追求性能的飛行愛好者，T-REX 550E V2 3GX 將是你最佳的選擇。

WARNING LABEL LEGEND 標誌代表涵義

 WARNING 警告	Mishandling due to failure to follow these instructions may result in damage or injury. 因為疏忽這些操作說明，而使用錯誤可能造成財產損失或嚴重傷害。
 CAUTION 注意	Mishandling due to failure to follow these instructions may result in danger. 因為疏忽這些操作說明，而使用錯誤可能造成危險。
 FORBIDDEN 禁止	Do not attempt under any circumstances. 在任何禁止的環境下，請勿嘗試操作。

IMPORTANT NOTES 重要聲明

R/C helicopters, including the T-REX 550E V2 3GX are not toys. R/C helicopter utilize various high-tech products and technologies to provide superior performance. Improper use of this product can result in serious injury or even death. Please read this manual carefully before using and make sure to be conscious of your own personal safety and the safety of others and your environment when operating all ALIGN products.

Manufacturer and seller assume no liability for the operation or the use of this product. Intended for use only by adults with experience flying remote control helicopters at a legal flying field. After the sale of this product we cannot maintain any control over its operation or usage.

T-REX 550E V2 3GX 遙控直昇機並非玩具，它是結合了許多高科技產品所設計出來的休閒用品，所以商品的使用不當或不熟悉都可能會造成嚴重傷害甚至死亡，使用之前請務必詳讀本說明書，勿輕忽並注意自身安全。

注意！任何遙控直昇機的使用，製造商和經銷商是無法對使用者於零件使用的損耗異常或組裝不當所發生之意外負任何責任，本產品是提供給有操作過模型直昇機經驗的成人，或有相當技術的人員在旁指導於當地合法遙控飛行場飛行，以確保安全無虞下操作使用。產品售出後本公司將不負任何操作和使用控制上的任何性能與安全責任。

We recommend that you obtain the assistance of an experienced pilot before attempting to fly our products for the first time. A local expert is the best way to properly assemble, setup, and fly your model for the first time. The Helicopter requires a certain degree of skill to operate, and is a consumer item. Any damage or dissatisfaction as a result of accidents or modifications are not covered by any warrantee and cannot be returned for repair or replacement. Please contact our distributors for free technical consultation and parts at discounted rates when you experience problems during operation or maintenance.

模型商品屬於需高操作技術且為消耗性之商品，如經拆裝使用後，會造成不等情況零件損耗，任何使用情況所造成商品不良或不滿意，將無法於保固條件內更換新品或退貨，如遇有使用操作維修問題，本公司全省分公司或代理商將提供技術指導、特價零件供應服務。

2.SAFETY NOTES 安全注意事項



Fly only in safe areas, away from other people. Do not operate R/C aircraft within the vicinity of homes or crowds of people. R/C aircraft are prone to accidents, failures, and crashes due to a variety of reasons including, lack of maintenance, pilot error, and radio interference. Pilots are responsible for their actions and damage or injury occurring during the operation or as of a result of R/C aircraft models.

遙控模型飛機、直昇機屬高危險性商品，飛行時務必遠離人群，人為組裝不當或機件損壞、電子控制設備不良，以及操控上的不熟悉、都有可能導致飛行失控損傷等不可預期的意外，請飛行者務必注意飛行安全，並需了解自負疏忽所造成任何意外之責任。



LOCATE AN APPROPRIATE LOCATION 遠離障礙物及人群

R/C helicopters fly at high speed, thus posing a certain degree of potential danger. Choose a legal flying field consisting of flat, smooth ground without obstacles.

Do not fly near buildings, high voltage cables, or trees to ensure the safety of yourself, others and your model.

For the first practice, please choose a legal flying field and can use a training skid to fly for reducing the damage. Do not fly your model in inclement weather, such as rain, wind, snow or darkness.

直昇機飛行時具有一定的速度，相對的也潛在著危險性，場地的選擇也相對的重要，請需遵守當地法規到合法遙控飛行場地飛行。

必須注意周遭有沒有人、高樓、建築物、高壓電線、樹木等等，避免操控的不當造成自己與他人財產的損壞。

初次練習時，務必選擇在空曠合法專屬飛行場地並適當搭配練習架練習飛行，這對飛行失誤所造成的損傷將會大幅的降低。請勿在下雨、打雷等惡劣天候下操作，以確保本身及機體的安全。



PREVENT MOISTURE 遠離潮濕環境

R/C models are composed of many precision electrical components.

It is critical to keep the model and associated equipment away from moisture and other contaminants. The introduction or exposure to water or moisture in any form can cause the model to malfunction resulting in loss of use, or a crash. Do not operate or expose to rain or moisture.

直昇機內部也是由許多精密的電子零組件組成，所以必須絕對的防止潮濕或水氣，避免在浴室或雨天時使用，防止水氣進入機身內部而導致機件及電子零件故障而引發不可預期的意外！



PROPER OPERATION 勿不當使用本產品

Please use the replacement of parts on the manual to ensure the safety of instructors.

This product is for R/C model, so do not use for other purpose.

請勿自行改造加工，任何的升級改裝或維修，請使用亞拓產品目錄中的零件，以確保結構的安全。請確認於產品限界內操作，請勿過載使用，並勿用於安全、法令外其它非法用途。



OBTAIN THE ASSISTANCE OF AN EXPERIENCED PILOT 避免獨自操控

Before turning on your model and transmitter, check to make sure no one else is operating on the same frequency. Frequency interference can cause your model, or other models to crash.

The guidance provided by an experienced pilot will be invaluable for the assembly, tuning, trimming, and actual first flight.

(Recommend you to practice with computer-based flight simulator.)

至飛行場飛行前，需確認是否有相同頻率的好手正進行飛行，因為開啓相同頻率的發射機將導致自己與他人立即干擾等意外危險。

遙控飛機操控技巧在學習初期有著一定的難度，要盡量避免獨自操作飛行，需有經驗的人士在旁指導，才可以操控飛行。(勤練電腦模擬器及老手指導是入門必要的選擇)



SAFE OPERATION 安全操作

Operate this unit within your ability. Do not fly under tired condition and improper operation may cause in danger.

請於自己能力內及需要一定技術範圍內操作這台直昇機，過於疲勞、精神不佳或不當操作，意外發生風險將可能會提高。



ALWAYS BE AWARE OF THE ROTATING BLADES 遠離運轉中零件

During the operation of the helicopter, the main rotor and tail rotor will be spinning at a high rate of speed. The blades are capable of inflicting serious bodily injury and damage to the environment. Be conscious of your actions, and careful to keep your face, eyes, hands, and loose clothing away from the blades. Always fly the model a safe distance from yourself and others, as well as surrounding objects. Never take your eyes off the model or leave it unattended while it is turned on. Immediately turn off the model and transmitter when you have landed the model.

當直昇機主旋翼與尾旋翼運轉時，切勿觸摸並遠離任何物件，以避免造成危險及損壞。



KEEP AWAY FROM HEAT 遠離熱源







R/C models are made of various forms of plastic. Plastic is very susceptible to damage or deformation due to extreme heat and cold climate. Make sure not to store the model near any source of heat such as an oven, or heater. It is best to store the model indoors, in a climate-controlled, room temperature environment.

遙控飛機多半是以 PA 纖維或聚乙烯、電子商品為主要材質，因此要盡量遠離熱源、日曬，以避免因高溫而變形甚至熔毀損壞的可能。











3.EQUIPMENT REQUIRED FOR ASSEMBLY 自備設備

RADIO TRANSMITTER AND ELECTRONIC EQUIPMENT REQUIRED FOR ASSEMBLY 自備遙控及電子設備

 <p>Transmitter (6-channel or more, helicopter system) 發射機(七動以上直昇機模式遙控器)</p>	 <p>Receiver(6-channel or more) 接收機(七動以上)</p>	<p>or 或</p>  <p>Remote receiver 衛星天線</p>
 <p>Li-Po Battery Charger RCC-6CX Li-Po電池充電器 RCC-6CX</p>	 <p>Pitch Gauge x 1pc 螺距規 x 1</p>	 <p>22.2V 6S 2600~5200mAh Li-Po Battery x 1pc 22.2V 6S 2600~5200mAh Li-Po電池 x 1</p>

ADDITIONAL TOOLS REQUIRED FOR ASSEMBLY 自備工具

 <p>Scissors 剪刀</p>	 <p>Cutter Knife 刀子</p>	 <p>Diagonal Cutting Pliers 斜口鉗</p>	 <p>Needle Nose Pliers 尖嘴鉗</p>
 <p>Oil 潤滑油</p>	 <p>CA 瞬間膠</p>	 <p>Hexagon Screw Driver 六角螺絲起子 3mm/2.5mm/2mm/1.5mm</p>	 <p>Philips Screw Driver 十字螺絲起子 φ3.0/φ1.8mm</p>

4.PACKAGE ILLUSTRATION 包裝說明

ALIGN

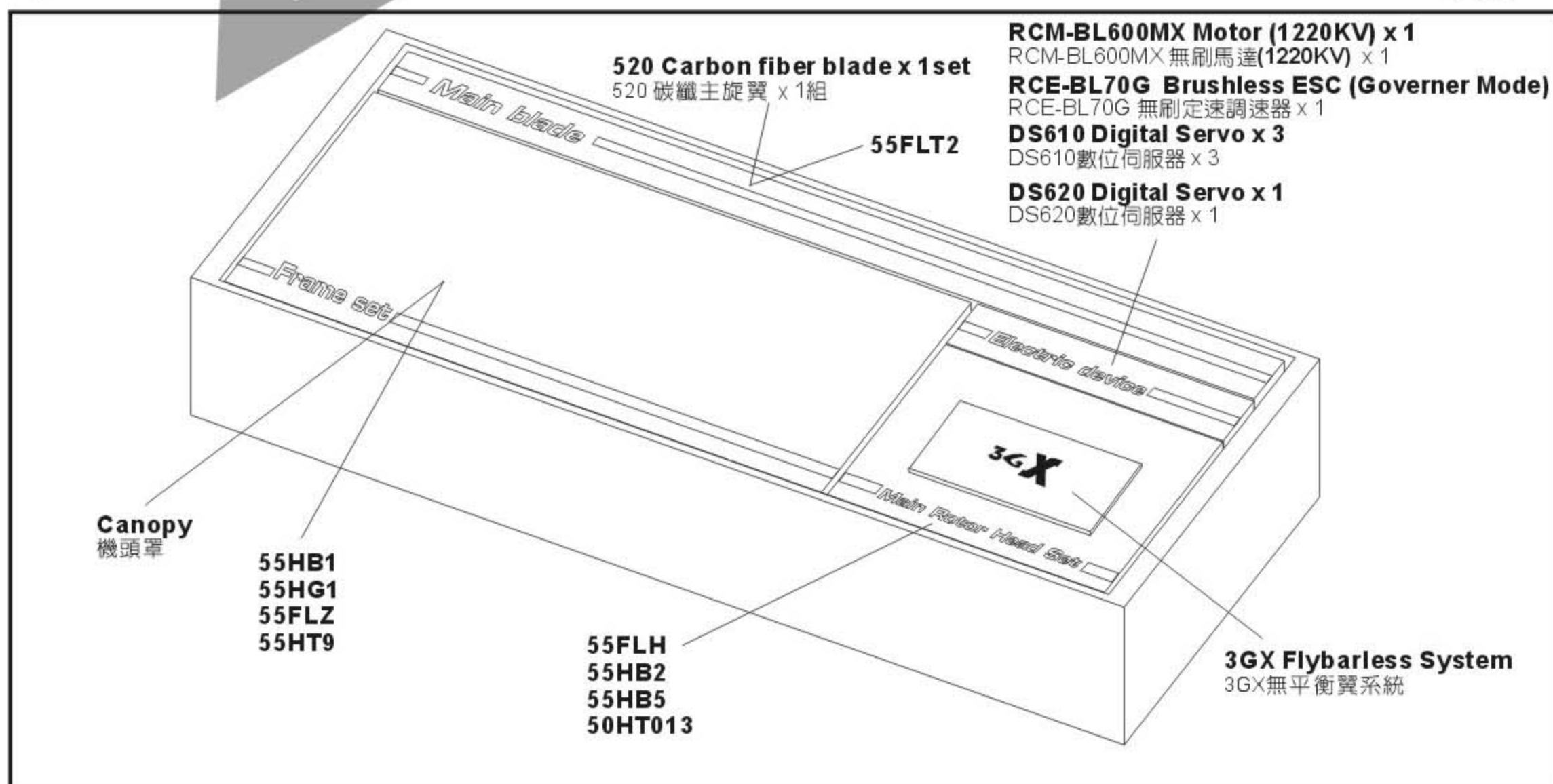

CAREFULLY INSPECT BEFORE REAL FLIGHT 請嚴格執行飛行前檢查義務

- ☆ Before flying, please check to make sure no one else is operating on the same frequency for the safety.
- ☆ Before flight, please check if the batteries of transmitter and receiver are enough for the flight.
- ☆ Before turn on the transmitter, please check if the throttle stick is in the lowest position. IDLE switch is OFF.
- ☆ When turn off the unit, please follow the power on/off procedure. Power ON- Please turn on the transmitter first, and then turn on receiver. Power OFF- Please turn off the receiver first and then turn off the transmitter. Improper procedure may cause out of control, so please to have this correct habit.
- ☆ Before operation, check every movement is smooth and directions are correct. Carefully inspect servos for interference and broken gear.
- ☆ Check for missing or loose screws and nuts. See if there is any cracked and incomplete assembly of parts. Carefully check main rotor blades and rotor holders. Broken and premature failures of parts possibly cause resulting in a dangerous situation.
- ☆ Check all ball links to avoid excess play and replace as needed. Failure to do so will result in poor flight stability.
- ☆ Check the battery and power plug are fastened. Vibration and violent flight may cause the plug loose and result out of control.
- ★ 每次飛行前應先確認所使用的頻率是否會干擾他人，以確保你自身與他人的安全。
- ★ 每次飛行前確定您發射機與接收機電池的電量是在足夠飛行的狀態。
- ★ 開機前確認油門搖桿是否位於最低點，熄火降落開關，定速開關(IDLE)是否於關閉位置。
- ★ 開機時必須遵守電源開關機的程序，開機時應先開啓發射機後，再開啓接收機電源；關機時應先關閉接收機後，再關閉發射機電源。不正確的開關程序可能會造失控的現象，影響自身與他人的安全，請養成正確的習慣。
- ★ 開機請先確定直昇機各個動作是否順暢，及方向是否正確，並檢查伺服器的動作是否有干涉或崩齒的情形，使用故障的伺服器將導致不可預期的危險。
- ★ 飛行前確認沒有缺少或鬆脫的螺絲與螺帽，確認沒有組裝不完整或損毀的零件，仔細檢查主旋翼是否有損壞，特別是接近主旋翼夾座的部位。損壞或組裝不完整的零件不僅影響飛行，更會造成不可預期的危險。注意：對損耗、有裂痕零件更新及定期保養檢查的重要性。
- ★ 檢查所有的連桿頭是否有鬆脫的情形，過鬆的連桿頭應先更新，否則將造成直昇機無法操控的危險。
- ★ 確認電池及電源接頭是否固定牢靠，飛行中的震動或激烈的飛行，可能造成電源接頭鬆脫而造成失控的危險。

Standard Equipment 標準配備

 55HC1	 55FLH	 55FLZ	 55HB1	 55HB2	 55HB5
 55HG1	 50HT013	 55HT9	 55FLT2	 3GX Flybarless System 3GX無平衡翼系統	
 M4x4止洩螺絲 x 1 Motor Pinion gear 16T x 1pcs 馬達齒輪 16T x 1	 RCM-BL600MX Motor (1220KV) x 1 RCM-BL600MX (1220KV) 無刷馬達 x 1	 DS610 Digital Servo x 3 DS620 Digital Servo x 1 DS610數位伺服器 x 3 DS620數位伺服器 x 1	 RCE-BL70G Brushless ESC (Governor Mode) RCE-BL70G 無刷定速調速器 x 1	 520 Carbon Fiber Blade 520 碳纖主旋翼	

When you see the marks as below, please use glue or grease to ensure flying safety.

標有下符號之組裝步驟，請配合上膠或上油，以確保使用之可靠度。



- CA: Apply CA Glue to fix.
- R48: Apply Anaerobics Retainer to fix.
- T43: Apply Thread Lock to fix.
- OIL: Add Grease.
- CA: 使用瞬間膠固定
- R48: 使用金屬管狀固定缺氧膠固定
- T43: 使用螺絲膠
- OIL: 添加潤滑油

When assembling ball links, make sure the "A" character faces outside.

各項塑膠製連桿頭扣接時，A字請朝外。



Grease
潤滑油



R48
綠色

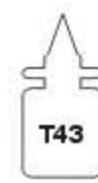

T43
藍色



Self-furnished
瞬間膠(自備)

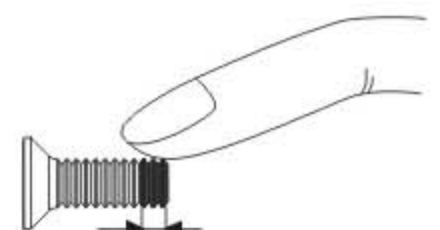

T43 Glue width: approx. 1mm
T43上膠寬度約1mm

R48 metal tubular adhesive (eg. Bearings). T43 thread lock, apply a small amount on screws or metal parts and wipe surplus off. When disassembling, recommend to heat the metal joint about 15 Seconds. (NOTE: Keep plastic parts away from heat.)

R48 為強力金屬管狀(如軸承)接著劑，T43為螺絲膠，膠合螺絲或金屬內外徑請務必少量使用，必要時請用手去除多餘膠量，欲拆卸時可於金屬接合部位熱烤約15秒。(注意！塑膠件避免接近熱源)

55FLH3

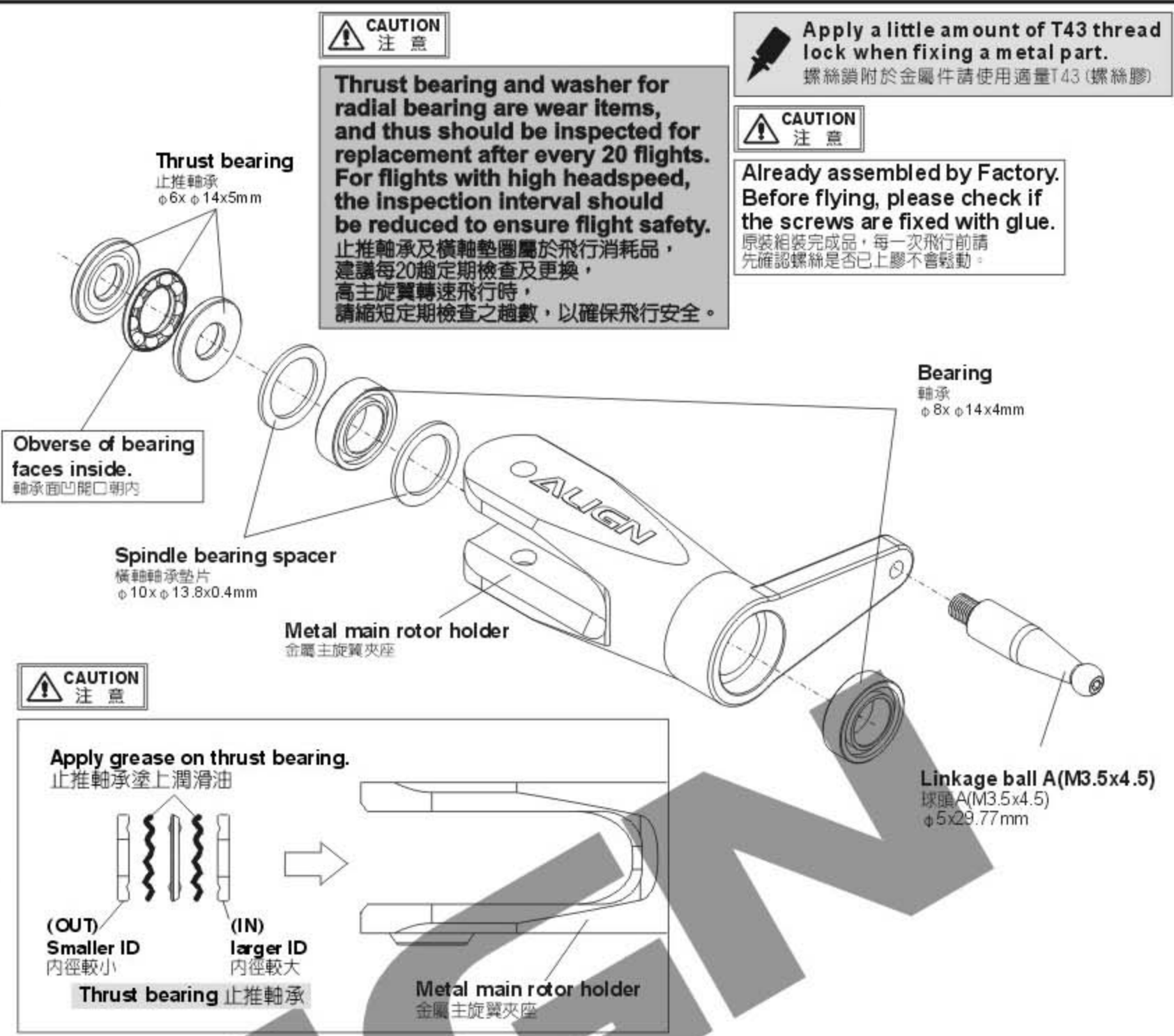
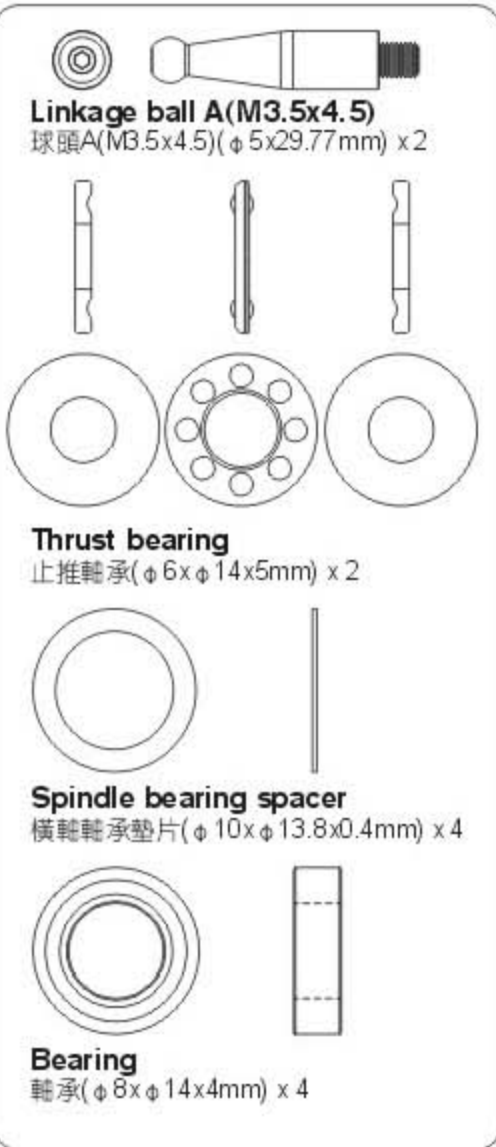

55FLH3

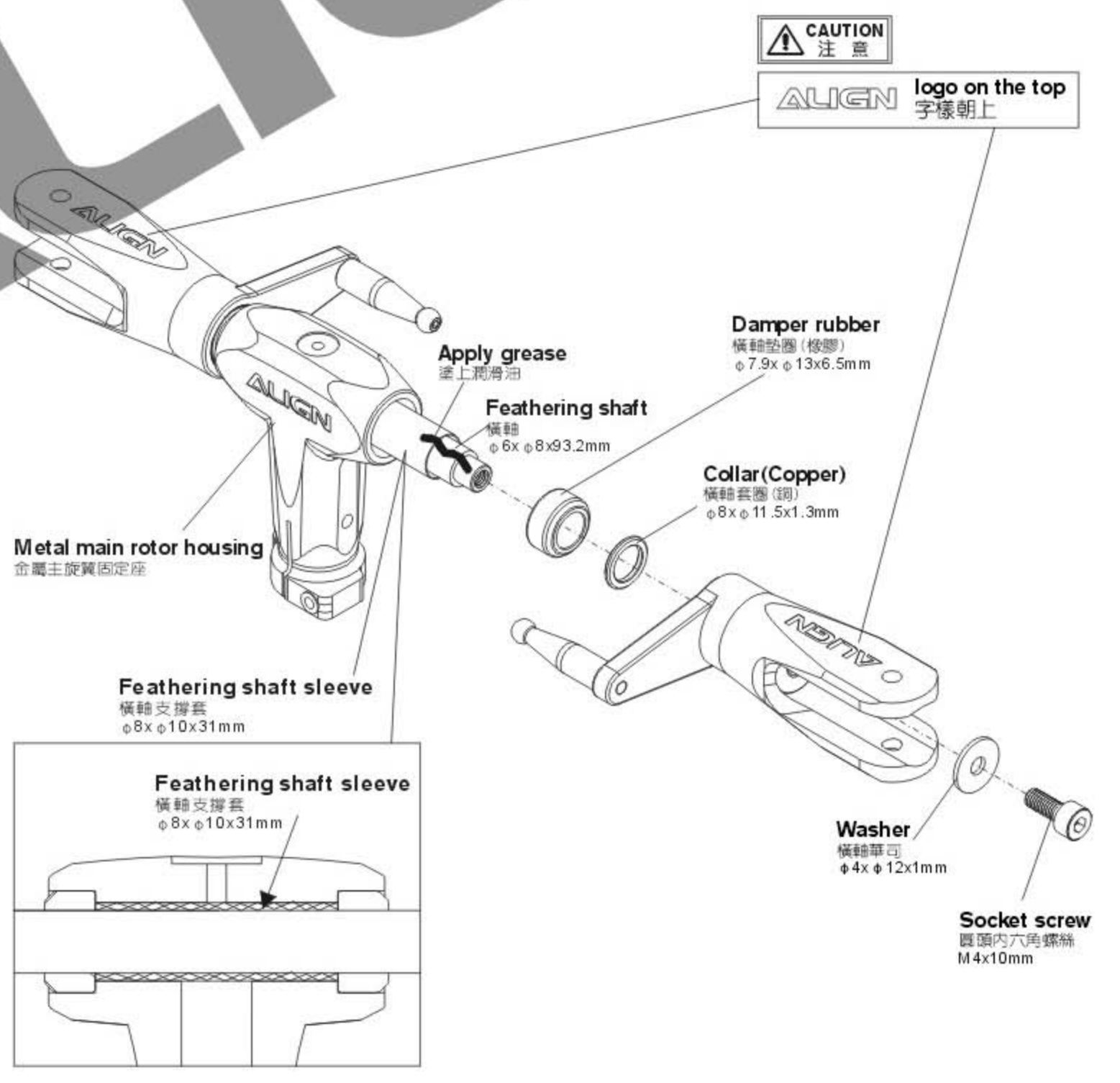
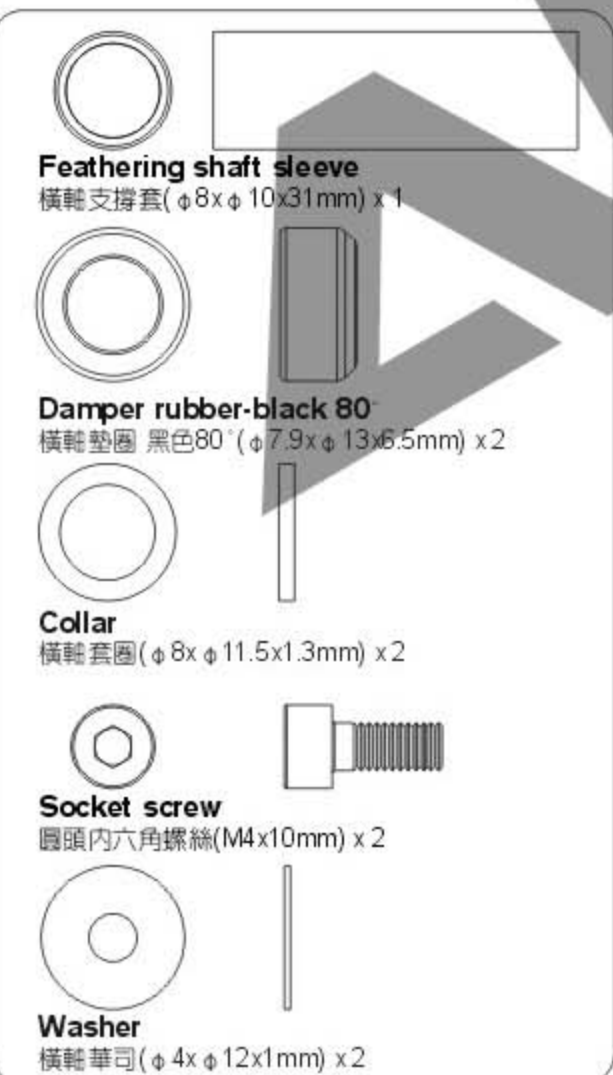

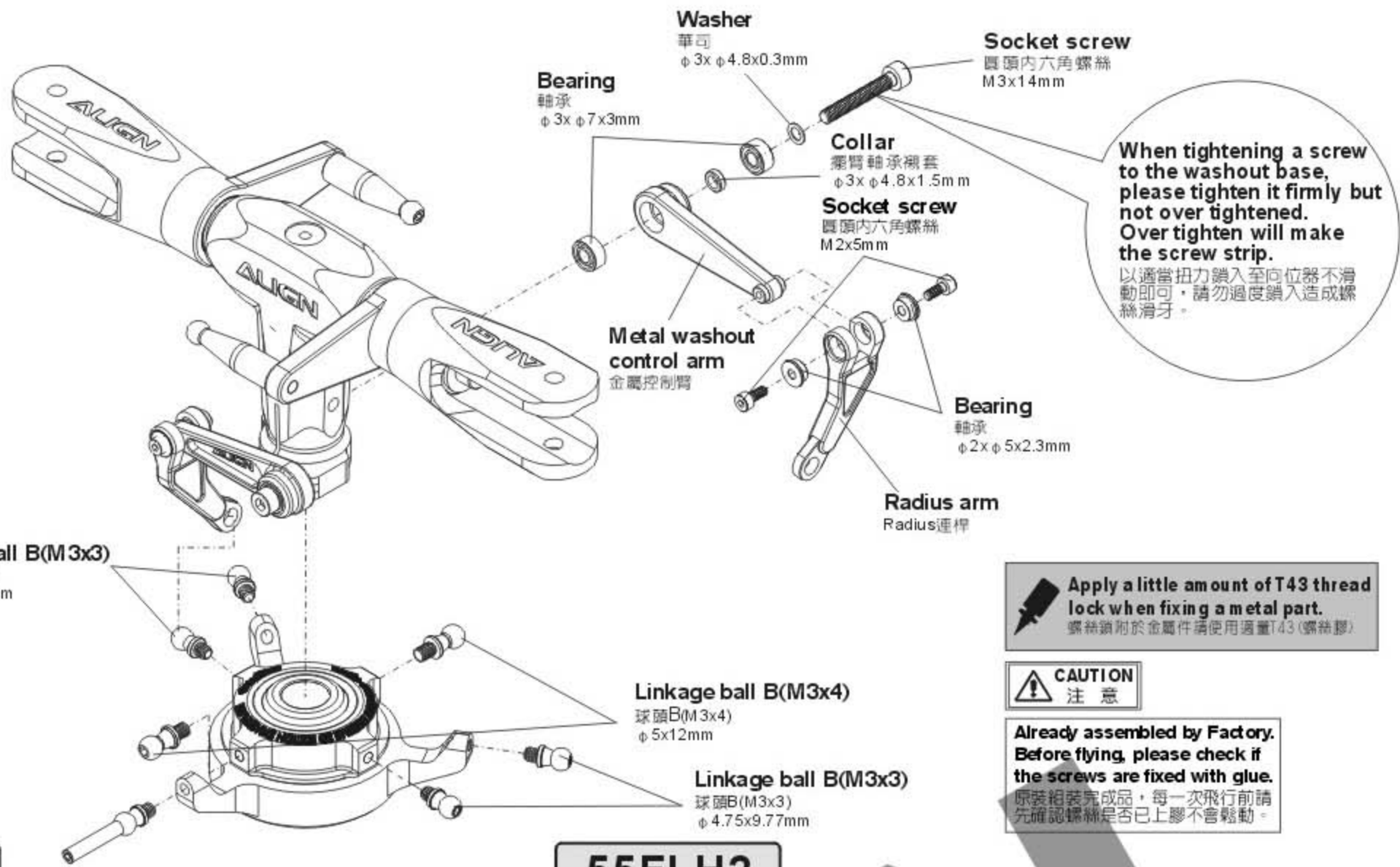

When tightening a screw to the washout base, please tighten it firmly but not over tightened. Over tighten will make the screw strip.
 以適當扭力鎖入至向位器不滑動即可。請勿過度鎖入造成螺絲滑牙。

Apply a little amount of T43 thread lock when fixing a metal part.
 螺絲鎖附於金屬件請使用適量T43(螺絲膠)

CAUTION
 注意

Already assembled by Factory. Before flying, please check if the screws are fixed with glue.
 原裝組裝完成品，每一次飛行前請先確認螺絲是否已上膠不會鬆動。

55FLZ4



55FLH2



55FLH3

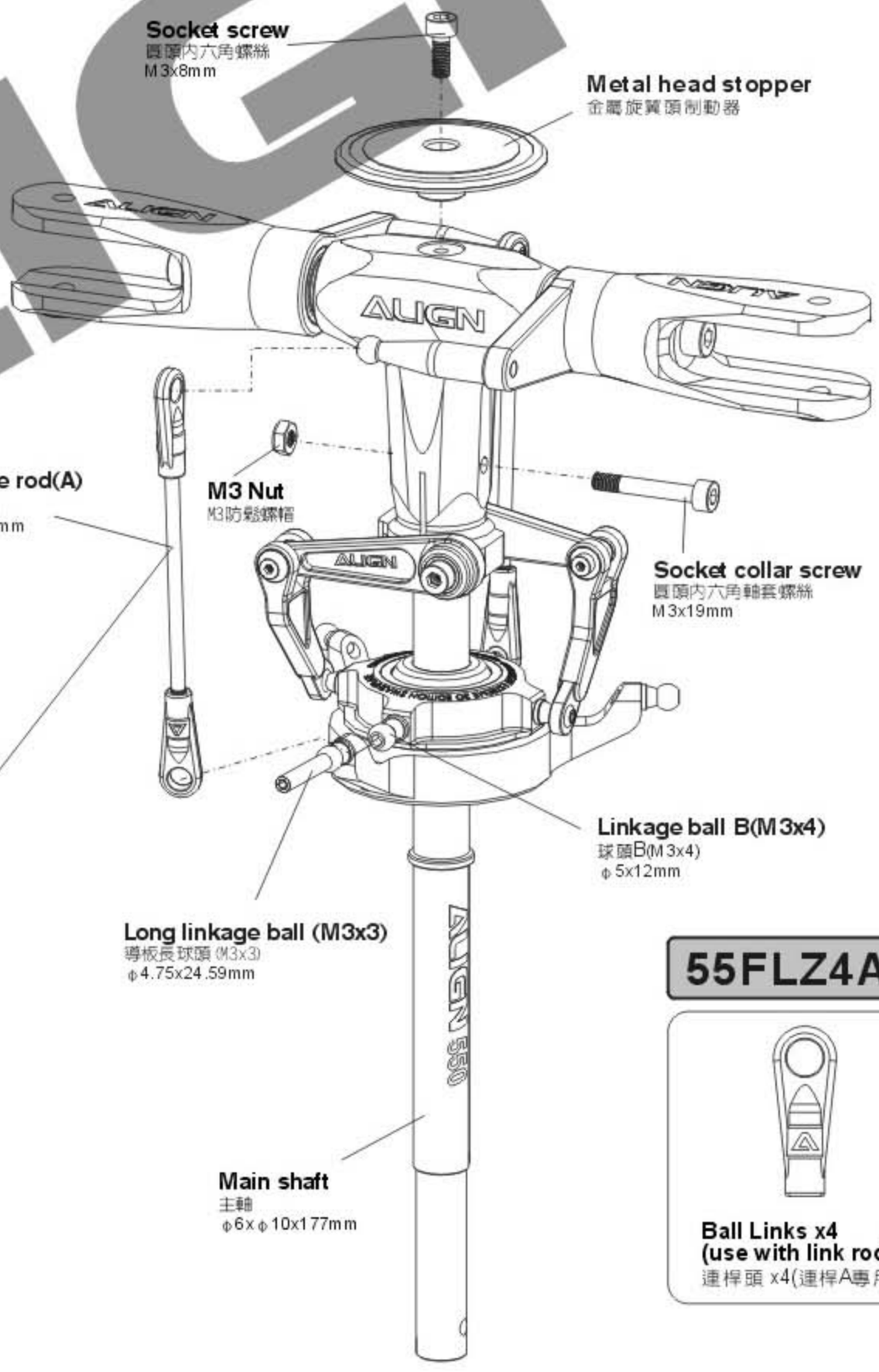
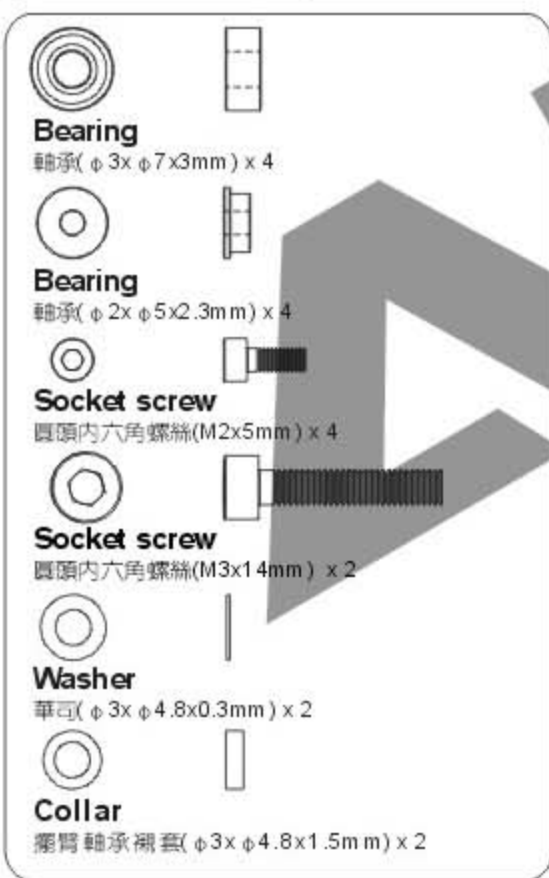

55FLH1A

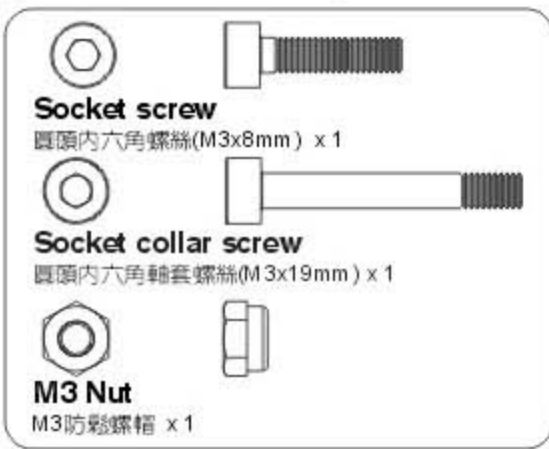

55FLZ4A



55HB2



Bearing
軸承(φ10xφ19x5mm) x 2

55HB2A



Socket collar screw
圓頭內六角軸套螺絲(M3x6mm) x 24



Socket button head screw
半圓頭內六角螺絲(M3x6mm) x 2

55HG1A



Socket screw
圓頭內六角螺絲(M3x10mm) x 4



M3 Set screw
M3止洩螺絲(M3x4mm) x 4



Washer
華司(φ3xφ8x1mm) x 4

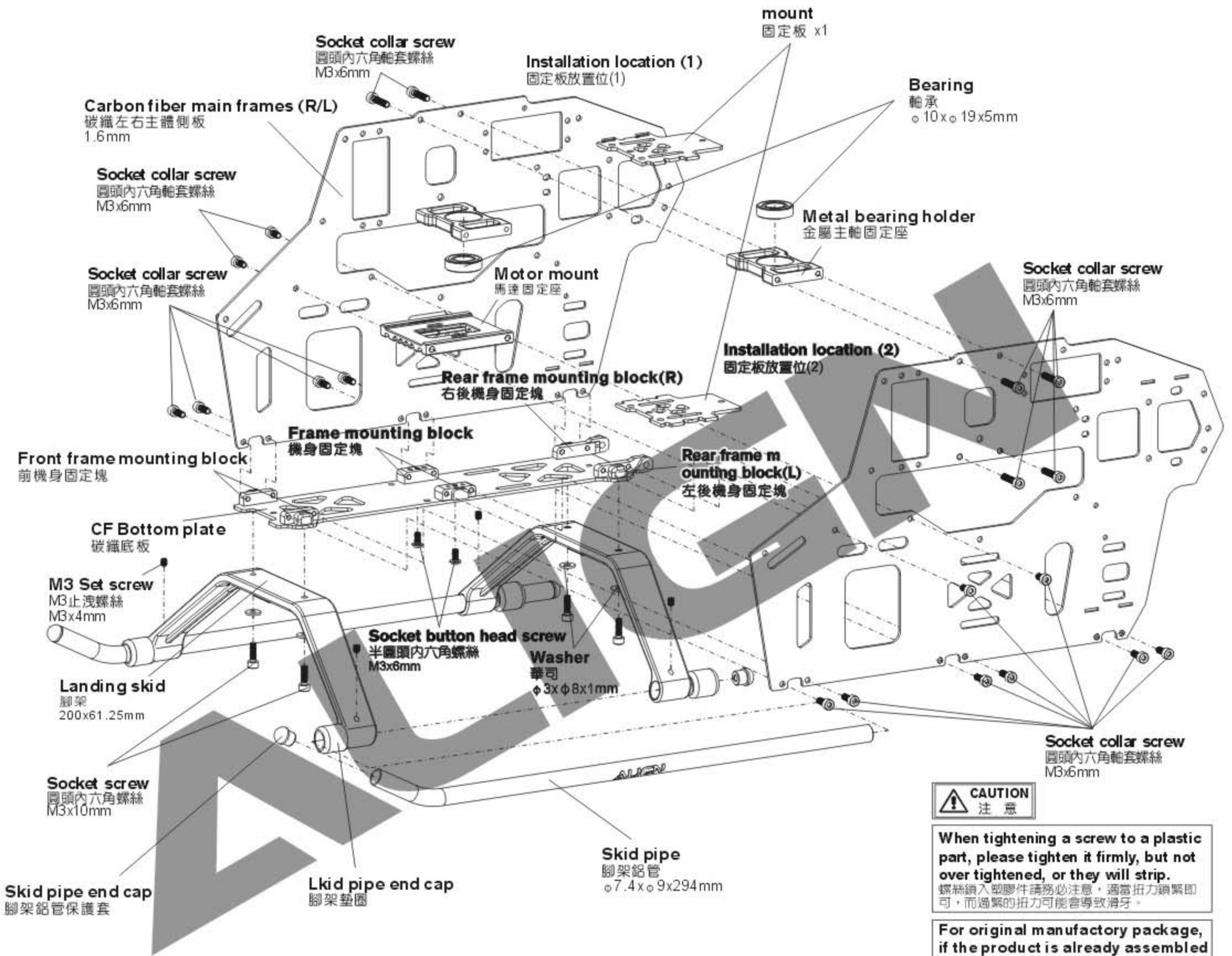

CAUTION 注意
When tightening a screw to a plastic part, please tighten it firmly, but not over tightened, or they will strip.
螺絲鎖入塑膠件請務必注意，適當扭力鎖緊即可，而過緊的扭力可能會導致滑牙。

For original manufactory package, if the product is already assembled by Factory, please check again if screws are firmly secured and applied with some glue.
原廠零件出廠包裝如果是組裝品，請需再確認各螺絲是否鎖緊上膠。

Apply a little amount of T43 thread lock when fixing a metal part.
螺絲鎖劑於金屬件請使用適量T43(藍絲膠)

Main frame assembly point:
First do not fully tighten the screws of main frames. Put the main shaft through the two bearings and check if the movements (up/down) are smooth. The bottom bracket must be firmly touched the level table top (glass surface); please keep the smooth movements on main shaft and level bottom bracket, then slowly tighten the screws. A correct assembly can help for the power and flight performance.

機身側板組立重點：
側板螺絲先不完全鎖緊，放入主軸貫穿二顆軸承確認上下移動必須滑順，主體底板必須與水平桌面(玻璃平面)踏實緊貼；請保持主軸滑順與底板平行桌面後慢慢鎖緊螺絲。正確側板的組裝對動力與飛行性能有顯著幫助。

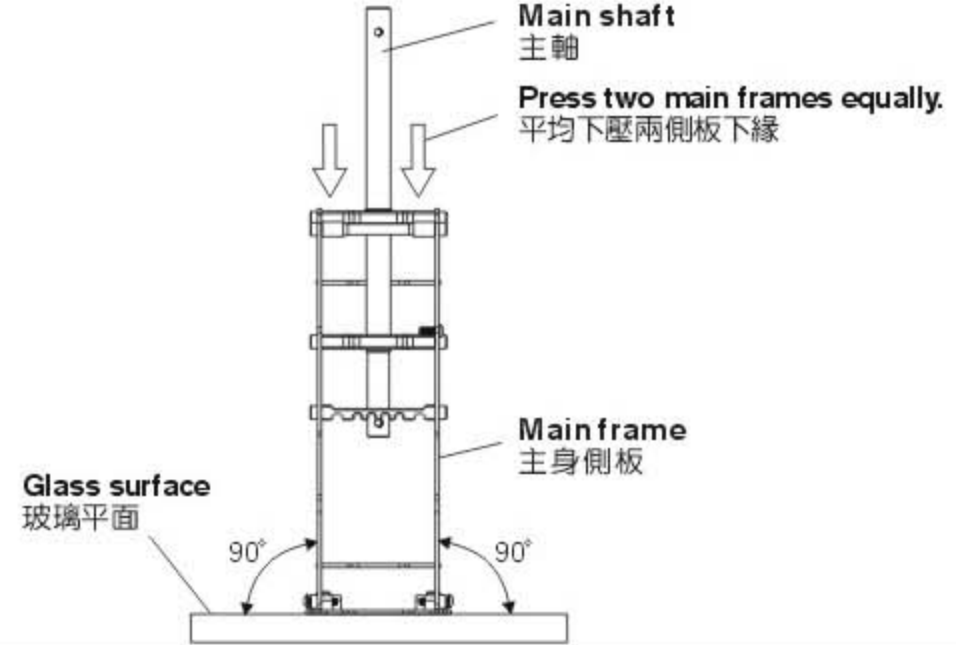

50HT013

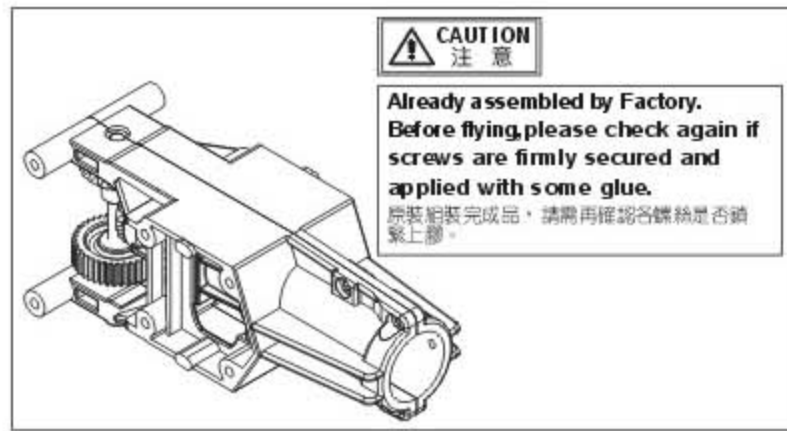
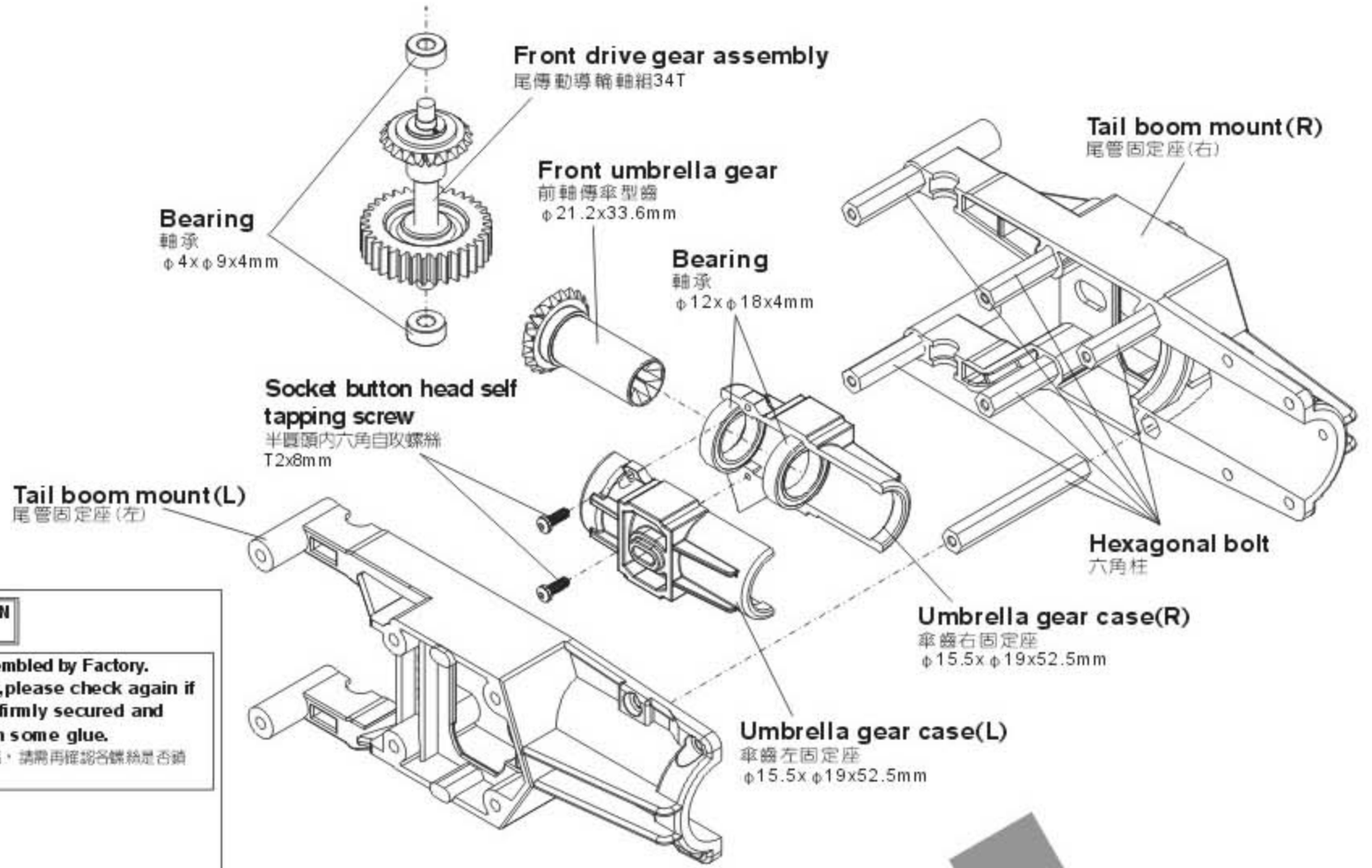
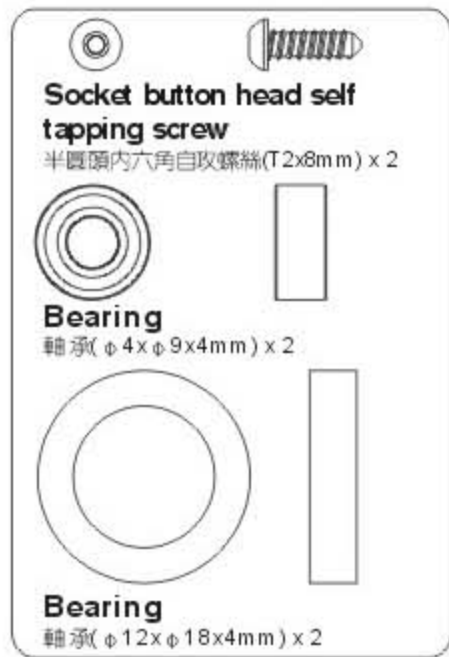

55HT9

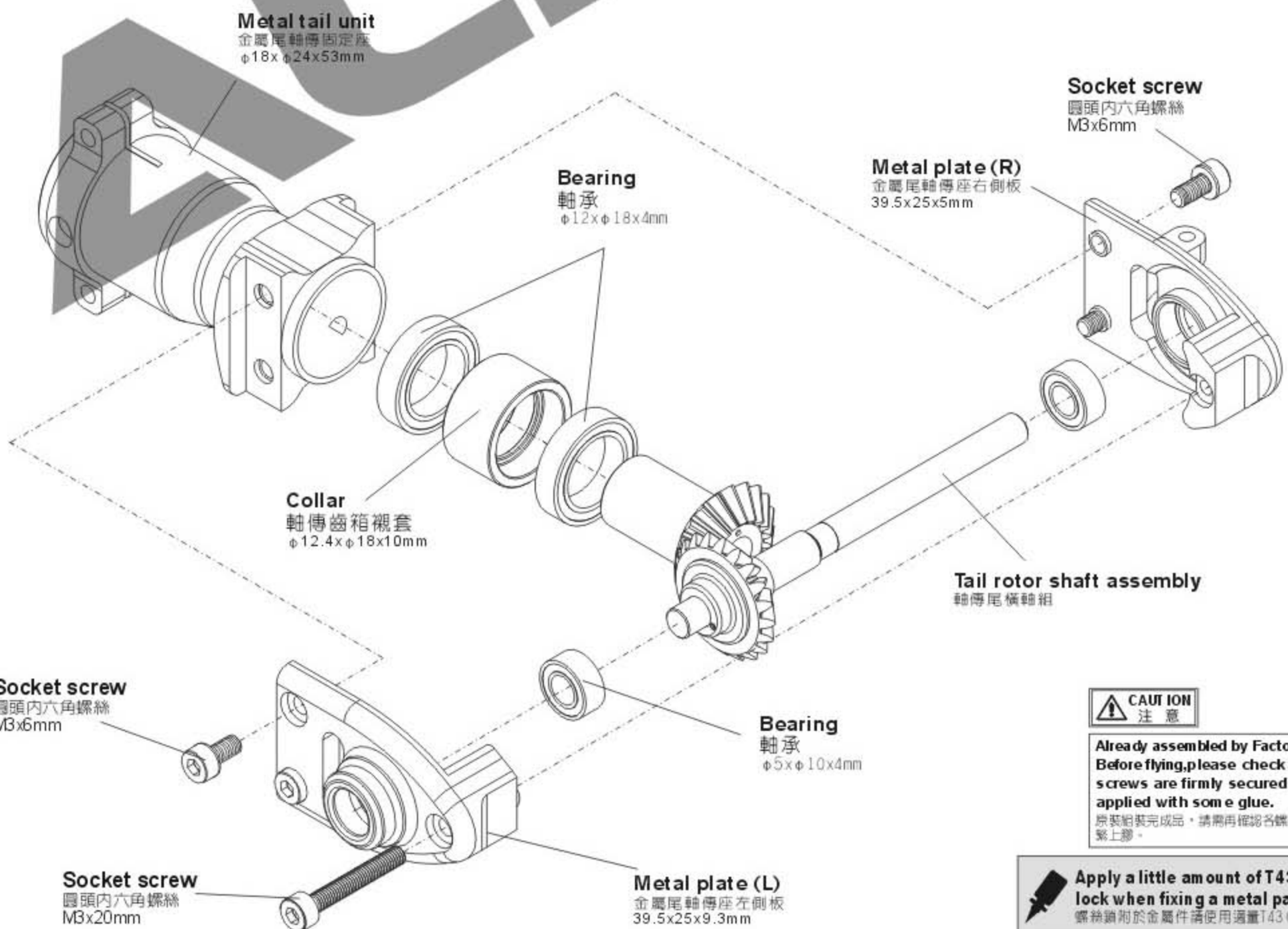

55HT9

Apply a little amount of T43 thread lock when fixing a metal part.
螺絲鎖附於金屬件請使用適量T43(螺絲膠)

- Socket screw**
圓頭內六角螺絲(M3x8mm) x 2
- Linkage ball A**
球頭A(M2x3.5)(ϕ 4.75x8.18mm) x 1
- Collar screw**
轉套螺絲(M2x8mm)(牙長3mm) x 2
- Collar screw**
轉套螺絲(M2x8mm)(牙長4.3mm) x 2
- Collar A**
尾連桿頭銅套A(ϕ 2x ϕ 3x4mm) x 2
- Linkage ball A**
球頭A(M2x2.5)(ϕ 4.75x7.18mm) x 1
- Collar**
尾控制轉套襯墊(ϕ 7x ϕ 8.3x3.5mm) x 1
- Bearing**
轉承(ϕ 5x ϕ 10x4mm) x 2
- Washer**
華司(ϕ 3x ϕ 4.8x0.3mm) x 2
- Bearing**
轉承(ϕ 3x ϕ 6x2.5mm) x 2
- Collar**
尾旋翼控制臂鋁套(ϕ 3x ϕ 4.9x5mm) x 1
- Collar**
尾控制轉套襯墊(ϕ 7x ϕ 8.3x3.5mm) x 1
- Bearing**
轉承(ϕ 7x ϕ 11x3mm) x 2
- Slide shaft**
尾轉滑套(ϕ 8x ϕ 7x17.6mm)x1
- Washer**
華司(ϕ 3x ϕ 8x1mm) x 2
- M4 Set screw**
M4止洩螺絲(M4x4mm) x 1
- Tail pitch bell crank sleeve**
尾旋翼控制球頭套(ϕ 7.6x ϕ 4.7x6.2mm) x 1

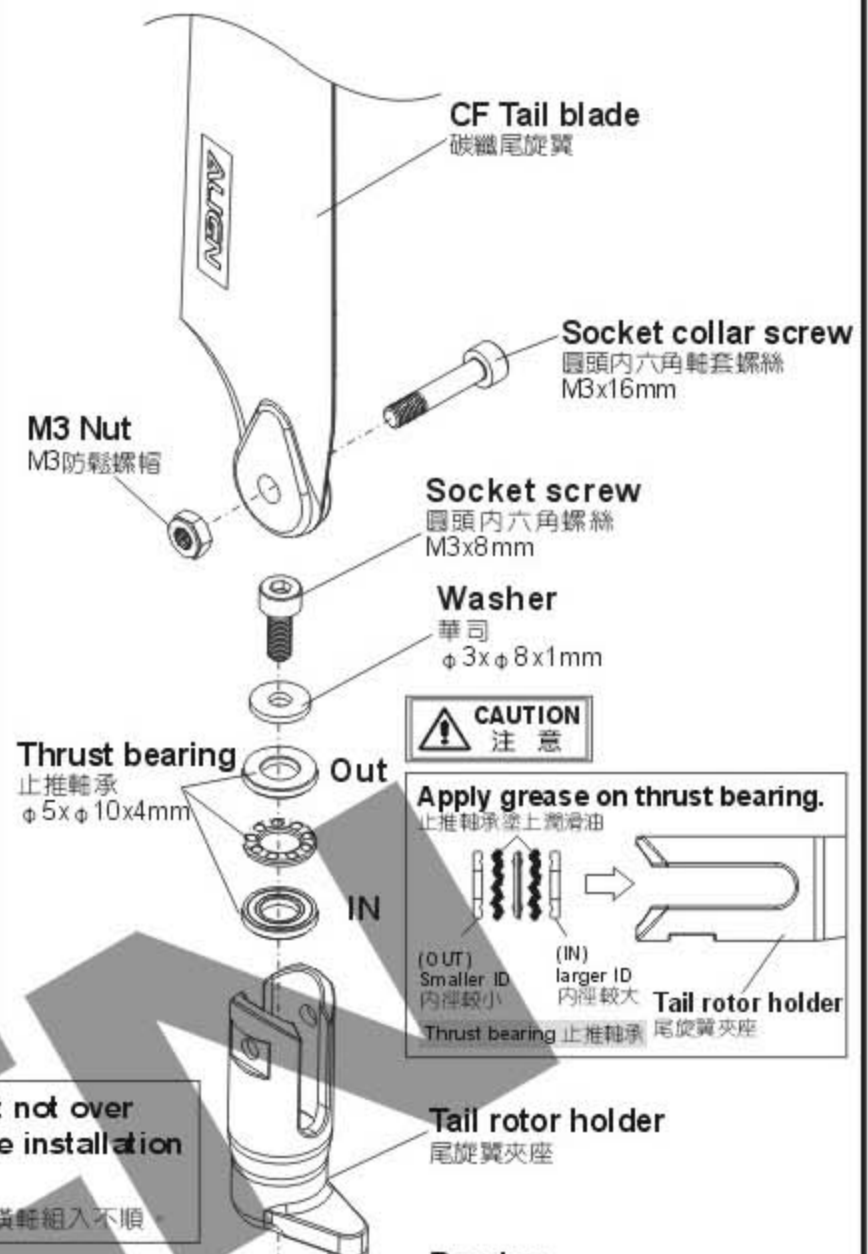

CAUTION 注意
Apply grease on thrust bearing.
止推轉承塗上潤滑油

(OUT) Smaller ID 內徑較小
(IN) larger ID 內徑較大
Tail rotor holder 尾旋翼夾座

Please tighten M2x8mm collar screw firmly but not over tightened. Over tighten the screw will cause the installation of tail rotor shaft unsmoothly.
鎖附M2x8mm轉套螺絲請使用適當力道，過度鎖緊會造成尾橫軸組入不順

CAUTION 注意

While assembly the slide shaft, please use suitable amount of T43 on the thread. Please do not use R48 anaerobics retainer or other high strength glue to avoid damages while maintenance or repairs.
組立尾軸滑套時，請使用適量的T43螺絲膠在螺牙上，嚴禁使用R48高膠合性軸承膠防止膠合過緊，以避免日後拆修維護零件之損傷。

Aim tail rotor hub at the concave of tail rotor shaft and fix it, please apply a little glue on the set screw.
尾旋翼T型座瞄準尾橫軸的凹刻並鎖上，請確認止洩螺絲上膠。

Assembling Umbrella Gear: Please note to push the gear to the end at a fixed position, to make sure the gears mesh with each other smoothly.
傘齒組裝：注意務必前推到底定位，以避免齒咬合不順暢。

55HT5

- Socket collar screw**
圓頭內六角轉套螺絲(M3x16mm) x 2
- M3 Nut**
M3防鬆螺帽 x 2

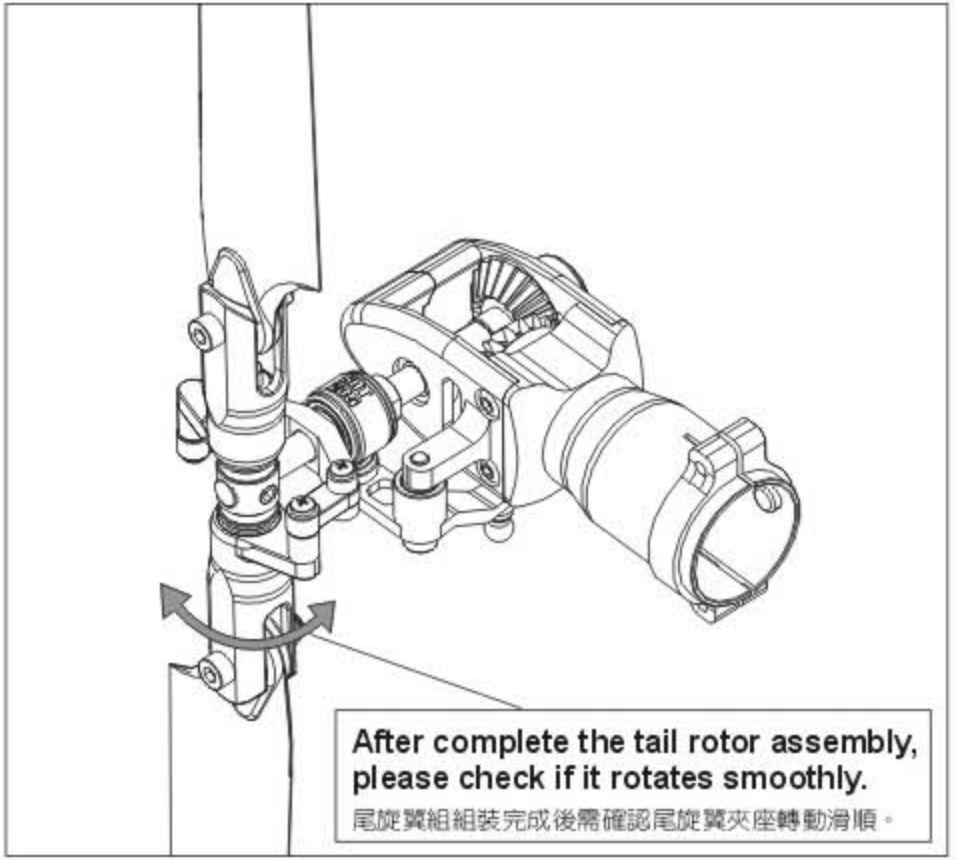
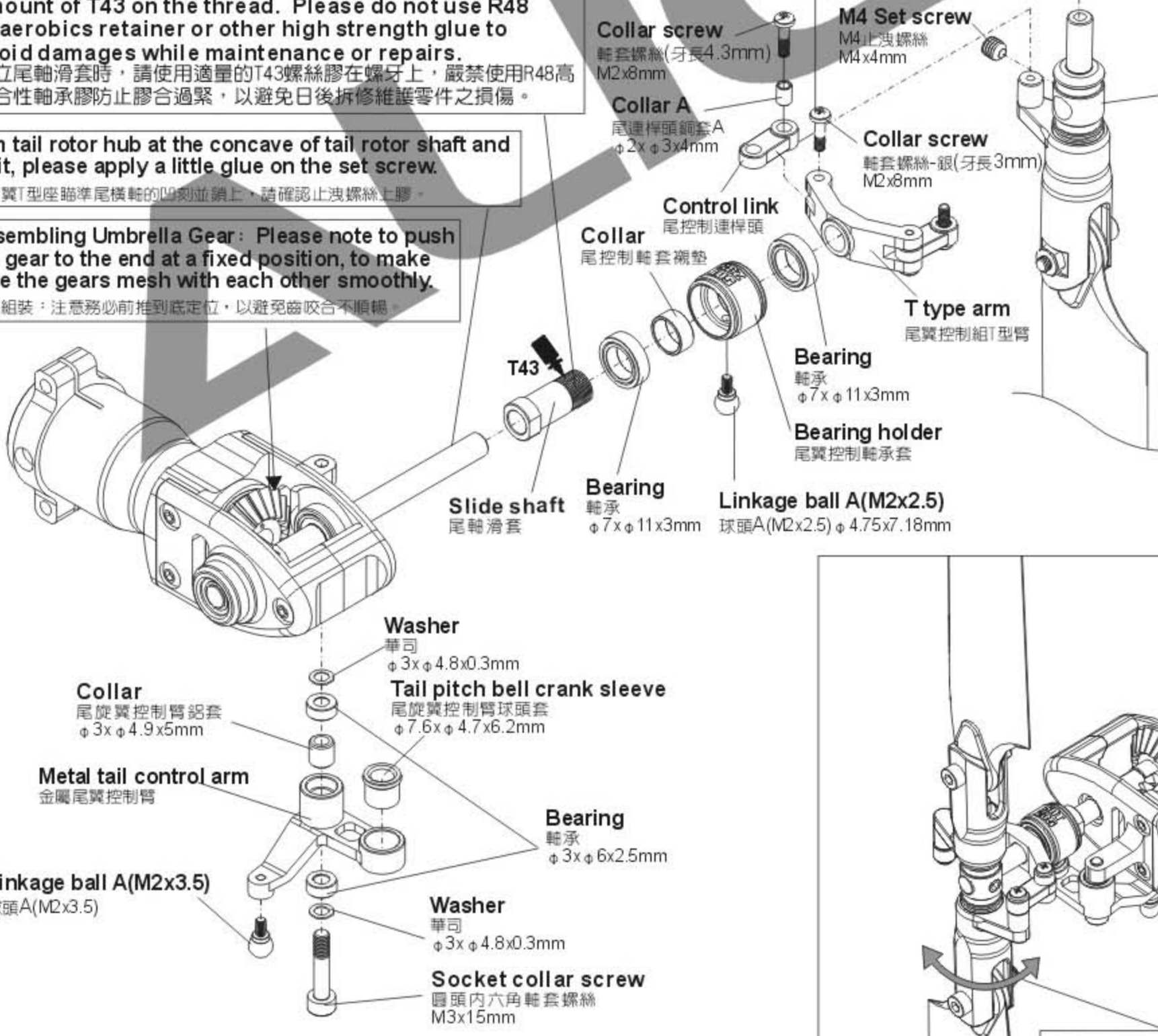

After complete the tail rotor assembly, please check if it rotates smoothly.
尾旋翼組裝完成後需確認尾旋翼夾座轉動滑順。

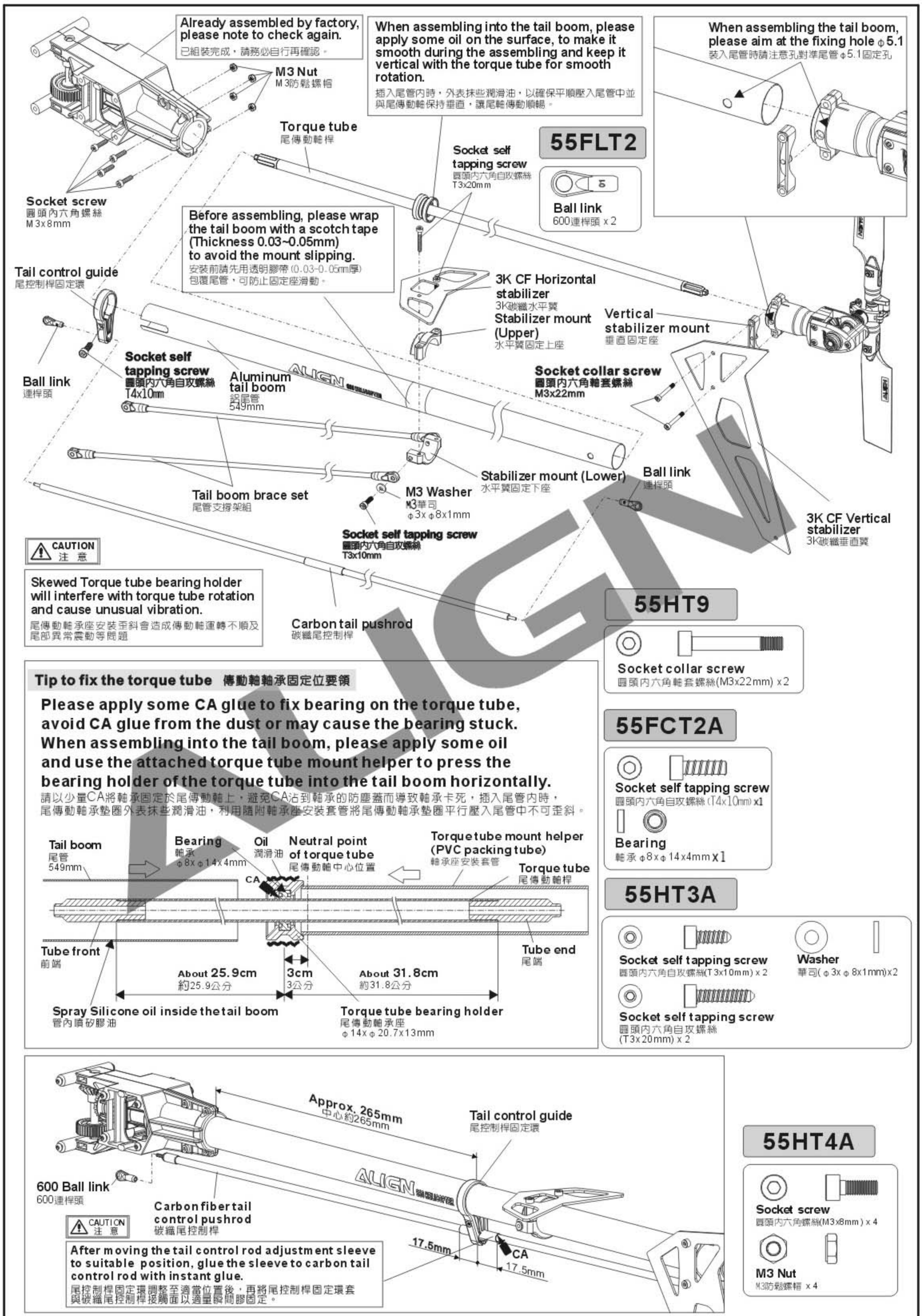

Already assembled by factory, please note to check again.
已組裝完成，請務必自行再確認。

When assembling into the tail boom, please apply some oil on the surface, to make it smooth during the assembling and keep it vertical with the torque tube for smooth rotation.
插入尾管內時，外表抹些潤滑油，以確保平順壓入尾管中並與尾傳動軸保持垂直，讓尾輪傳動順暢。

When assembling the tail boom, please aim at the fixing hole $\phi 5.1$
裝入尾管時請注意孔對準尾管 $\phi 5.1$ 固定孔

Before assembling, please wrap the tail boom with a scotch tape (Thickness 0.03~0.05mm) to avoid the mount slipping.
安裝前請先用透明膠帶 (0.03~0.05mm厚) 包覆尾管，可防止固定座滑動。

CAUTION
注意

Skewed Torque tube bearing holder will interfere with torque tube rotation and cause unusual vibration.
尾傳動軸承座安裝歪斜會造成傳動軸運轉不順及尾部異常震動等問題

Tip to fix the torque tube 傳動軸軸承固定位要領

Please apply some CA glue to fix bearing on the torque tube, avoid CA glue from the dust or may cause the bearing stuck. When assembling into the tail boom, please apply some oil and use the attached torque tube mount helper to press the bearing holder of the torque tube into the tail boom horizontally.
請以少量CA將軸承固定於尾傳動軸上，避免CA沾到軸承的防塵蓋而導致軸承卡死，插入尾管內時，尾傳動軸承墊圈外表抹些潤滑油，利用隨附軸承座安裝套管將尾傳動軸承墊圈平行壓入尾管中不可歪斜。

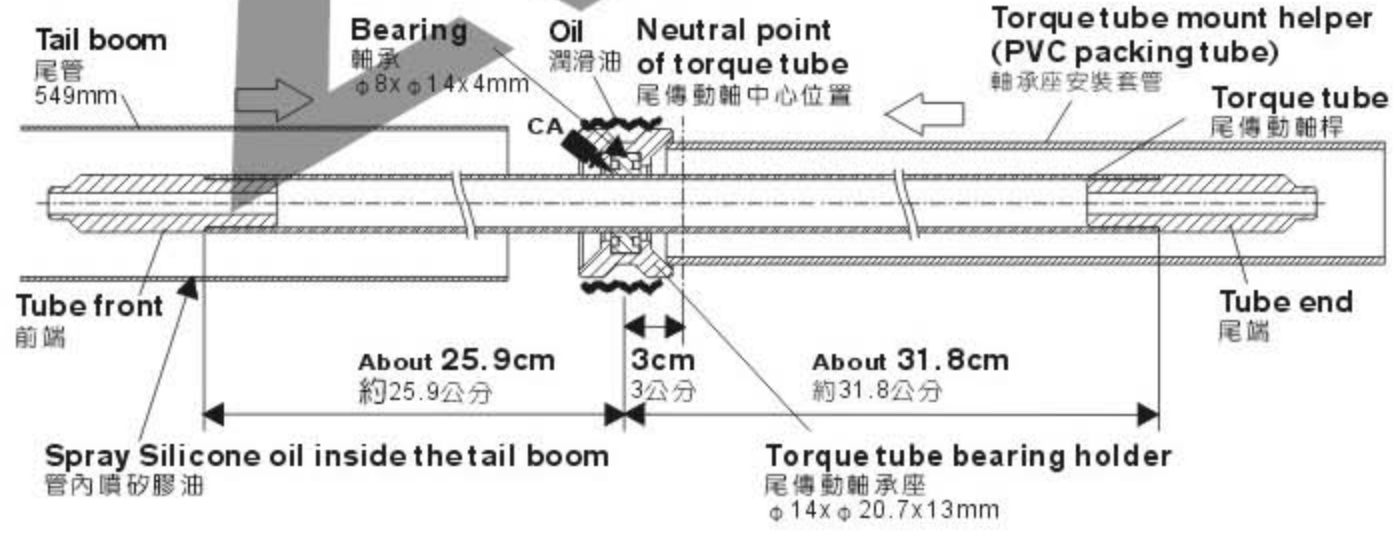

55HT9

Socket collar screw
圓頭內六角軸套螺絲 (M3x22mm) x 2

55FCT2A

Socket self tapping screw
圓頭內六角自攻螺絲 (T4x10mm) x 1
Bearing
軸承 $\phi 8 \times \phi 14 \times 4 \text{mm}$ x 1

55HT3A

Socket self tapping screw
圓頭內六角自攻螺絲 (T3x10mm) x 2
Washer
華司 ($\phi 3 \times \phi 8 \times 1 \text{mm}$) x 2
Socket self tapping screw
圓頭內六角自攻螺絲 (T3x20mm) x 2

55HT4A

Socket screw
圓頭內六角螺絲 (M3x8mm) x 4
M3 Nut
M3防鬆螺帽 x 4

CAUTION
注意

After moving the tail control rod adjustment sleeve to suitable position, glue the sleeve to carbon tail control rod with instant glue.
尾控制桿固定環調整至適當位置後，再將尾控制桿固定環套與碳纖維尾控制桿接觸面以適量瞬間膠固定。

55HT4A



55HB2B



50HT013



Apply a little amount of T43 thread lock when fixing a metal part.
螺絲鎖附於金屬件請使用適量T43(鎖絲膠)

CAUTION
注意

When tightening a screw to a plastic part, please tighten it firmly, but not over tightened, or they will strip.
螺絲鎖入塑膠件請務必注意，適當扭力鎖緊即可，而過緊的扭力可能會導致滑牙。

For original manufactory package, if the product is already assembled by Factory, please check again if screws are firmly secured and applied with some glue.
原廠零件出廠包裝如果是組裝品，請再確認各螺絲是否鎖緊上膠。

Socket button head self tapping screw
半圓頭內六角白攻螺絲
T3x10mm

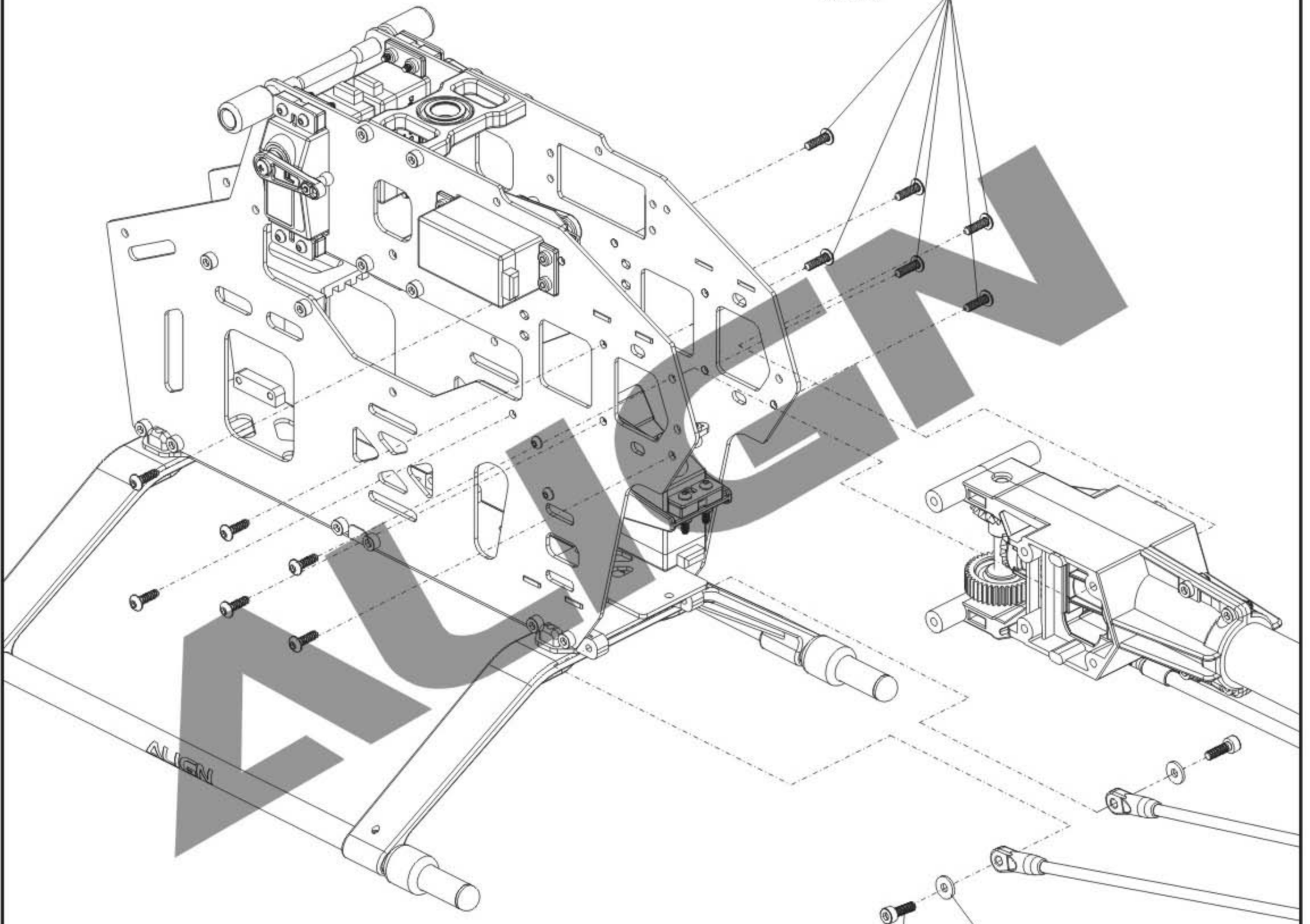

Socket screw
圓頭內六角螺絲
M3x10mm

Washer
華司
φ3xφ8x1mm

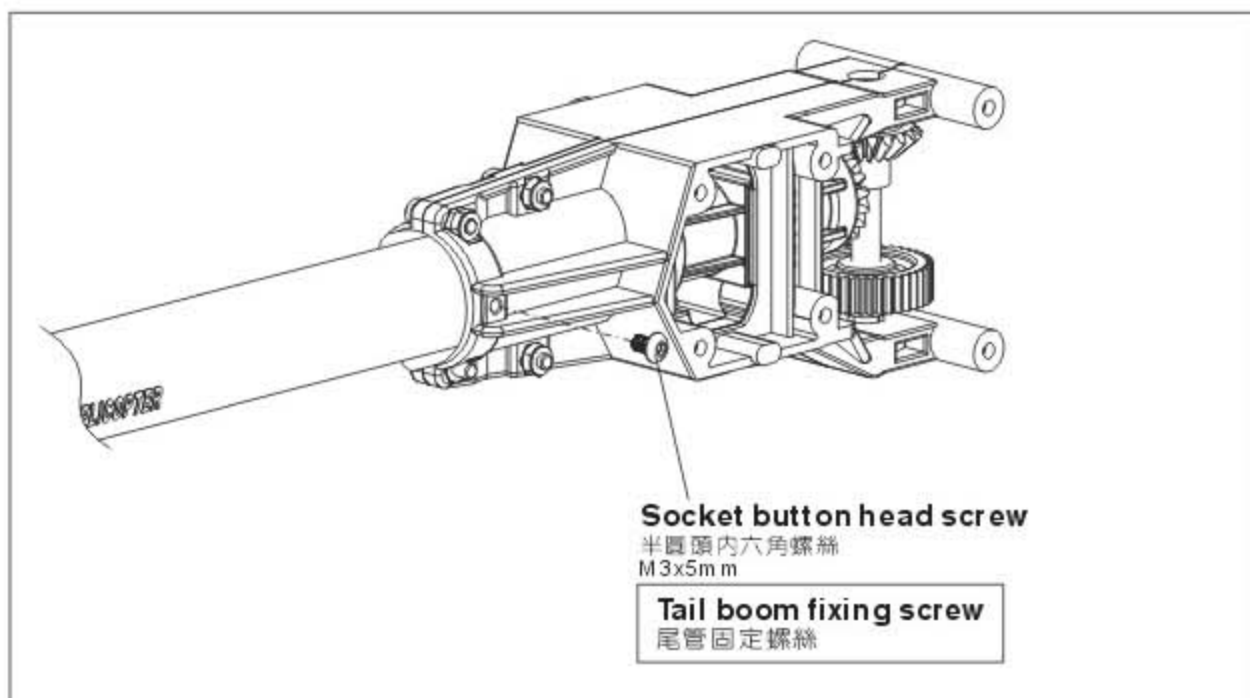

Apply a little amount of T43 thread lock when fixing a metal part.
螺絲鎖附於金屬件請使用適量T43(螺絲膠)

55FLZ4A



55HB2A



55HB2B



55HB5



55FLZ4

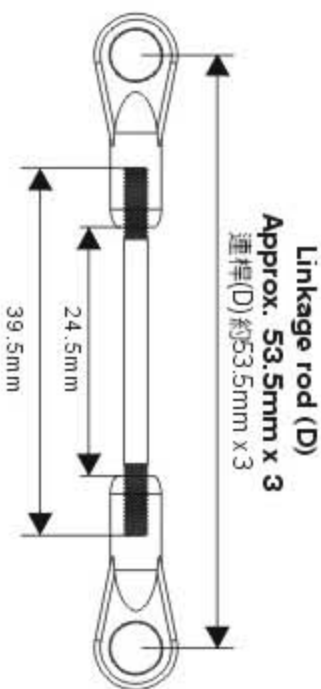

Standard Equipment :
Main shaft spacer(0.5)
Main shaft spacer(0.3)
標準品：主軸墊片(0.5)
φ 10.1xφ 14x0.5mm
主軸墊片(0.3)
φ 10.1xφ 14x0.3mm



Main drive gear set
主齒輪組

M3 Nut
M3防鬆螺帽

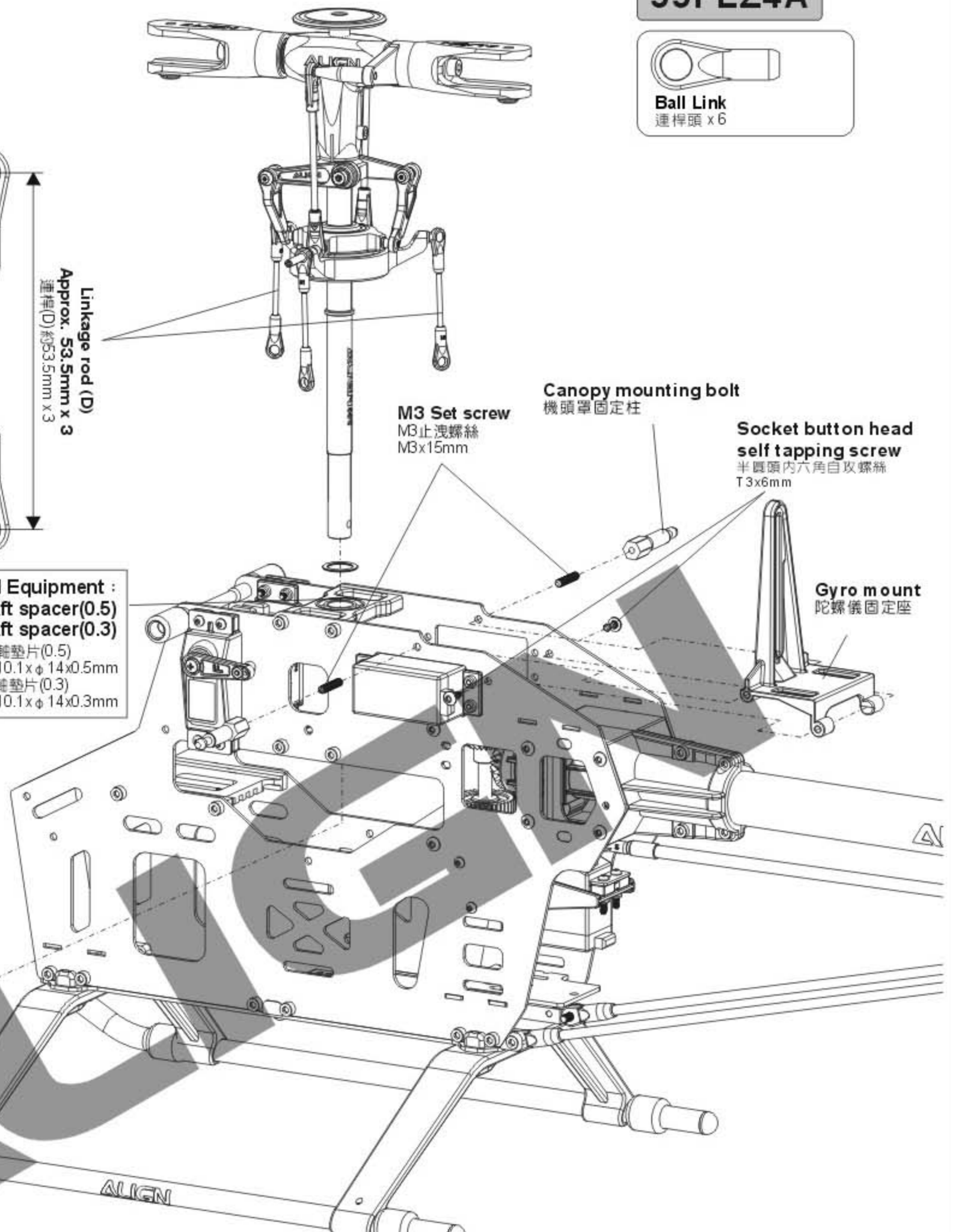

55HB5



Bearing
軸承(φ 12xφ 18x4mm) x 1

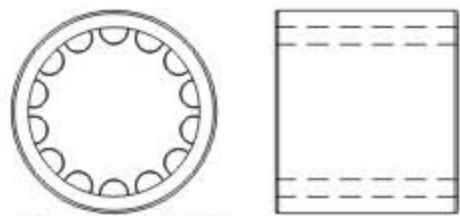

One-way bearing
單向軸承(φ 12xφ 18x16mm) x 1



Washer
單向軸承華司(φ 11.5xφ 18x0.8mm) x 1

Autrotation tail drive gear
尾驅動主齒
131T

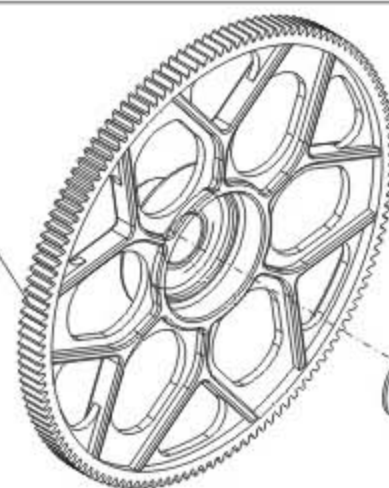

Washer
單向軸承華司
φ 11.5xφ 18x0.8mm

Main drive gear
主齒輪
170T

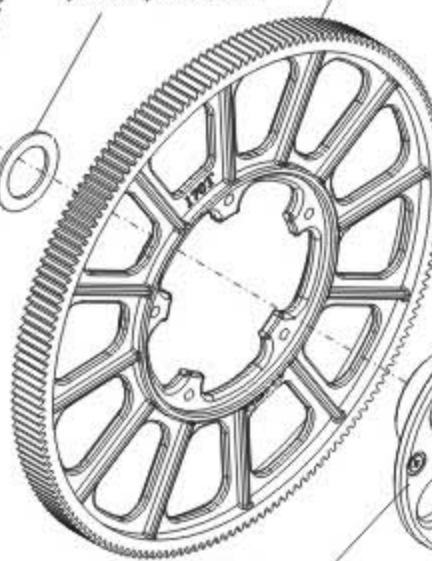

One-way bearing
單向軸承
φ 12xφ 18x16mm

Already assembled by factory, please note to check again.
已組裝完成，請務必自行再確認。

Flat head self tapping screw
圓頭內六角自攻螺絲
T3x7mm

Bearing
軸承
φ 12xφ 18x4mm

One-way bearing shaft
單向軸承套
φ 9xφ 12x34.7mm

Main gear case
主齒中心座

Apply grease
塗上潤滑油

One-way bearing shaft
單向軸承套(φ 9xφ 12x34.7mm)X1



Flat head self tapping screw
圓頭內六角自攻螺絲(T3x7mm)X6

CAUTION
注意

Already assembled by factory. Before flying, please check if the screws are fixed with glue.
原裝組裝完成品，每一次飛行前請先確認螺絲是否已上膠不會鬆動。

Before tightening the screw, please rotate the bearing and check the concentricity of the bearing. Then apply some glue evenly on the screw and tighten it firmly, to avoid the bearing stuck or heavy load at one side and cause slip.

上緊螺絲前請試轉動確認軸承同心度良好後，才能將螺絲平均上膠鎖緊，以避免造成卡死或單向重負載可能產生的打滑。

Apply a little amount of T43 thread lock when fixing a metal part.
 螺絲鎖附於金屬件請使用適量T43(螺絲膠)

CAUTION
 注意

When tightening a screw to a plastic part, please tighten it firmly, but not over tightened, or they will strip.
 螺絲鎖入塑膠件請務必注意，適當扭力鎖緊即可，而過緊的扭力可能會導致滑牙。

For original manufactory package, if the product is already assembled by Factory, please check again if screws are firmly secured and applied with some glue.
 原廠零件出廠包裝如果是組裝品，請需再確認各螺絲是否鎖緊上膠。

55FLH3A

-  **Socket collar screw**
圓頭內六角軸套螺絲(M4x25mm) x 2
-  **M4 Nut**
M4防鬆螺帽 x 2

55HB2B

-  **Socket button head self tapping screw**
半圓頭內六角自攻螺絲(T3x6mm) x 4

M4 Set screw
M4止洩螺絲
M4x4mm

Motor pinion gear 16T
馬達齒輪 16T

Socket button head self tapping screw
半圓頭內六角自攻螺絲
T3x6mm

M3 Washer
M3華司
φ3xφ8x1mm

For motor fixing
馬達固定螺絲
Socket screw
圓頭內六角螺絲
M3x10mm

Battery mount
電池固定座

Socket collar screw
圓頭內六角軸套螺絲
M4x25mm

520 Carbon fiber blade
520碳纖維主旋翼

M4 Nut
M4防鬆螺帽

When fixing the screw of pinion gear, please aim at the fixing point on motor shaft.
 馬達齒輪固定螺絲鎖緊時，請對準馬達心軸固定槽。

After assembling the motor pinion gear and main drive gear, the horizontal distance must be within 1mm and keep the gear mesh at a proper distance.
 馬達齒輪與主齒盤組立後平行距離不可超過1mm，並保持兩齒咬合有適當間距。

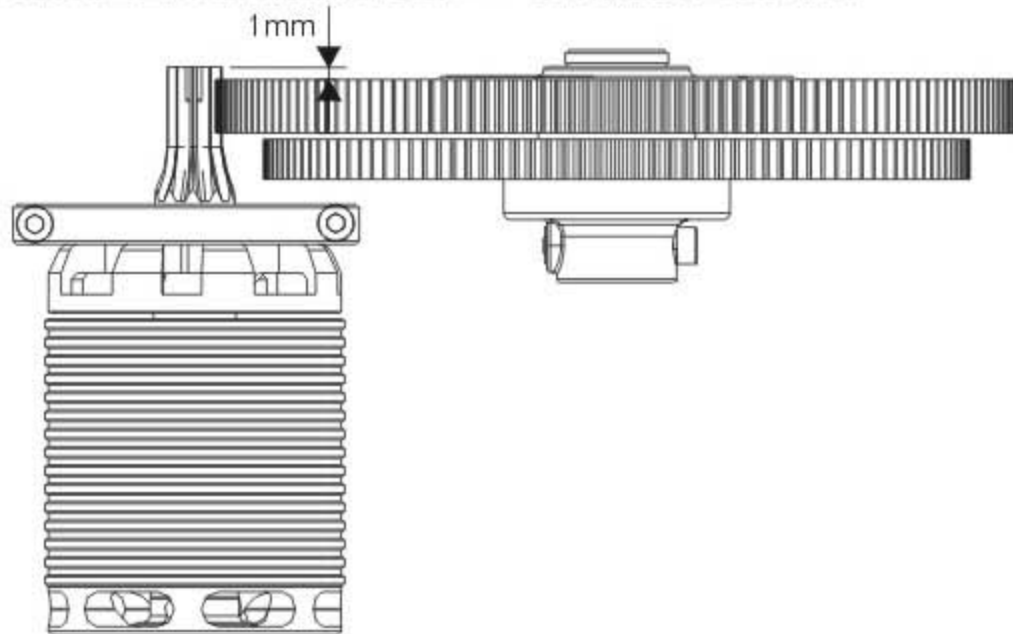

55HZ5

-  **M4 Set screw**
M4止洩螺絲(M4x4mm) x 1
-  **Socket screw**
圓頭內六角螺絲(M3x10mm) x 2
-  **Washer**
華司(φ3xφ8x1mm)x2

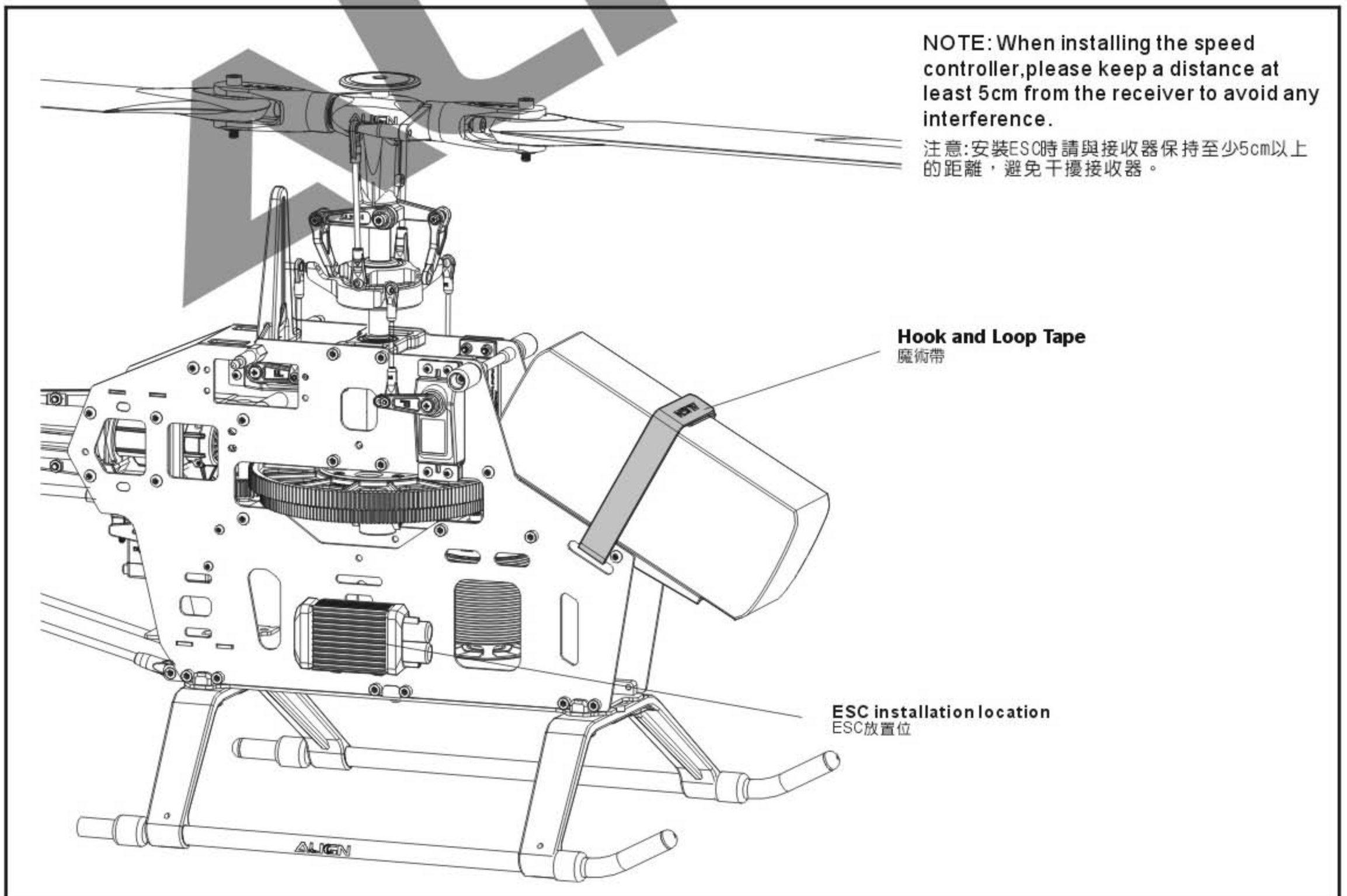
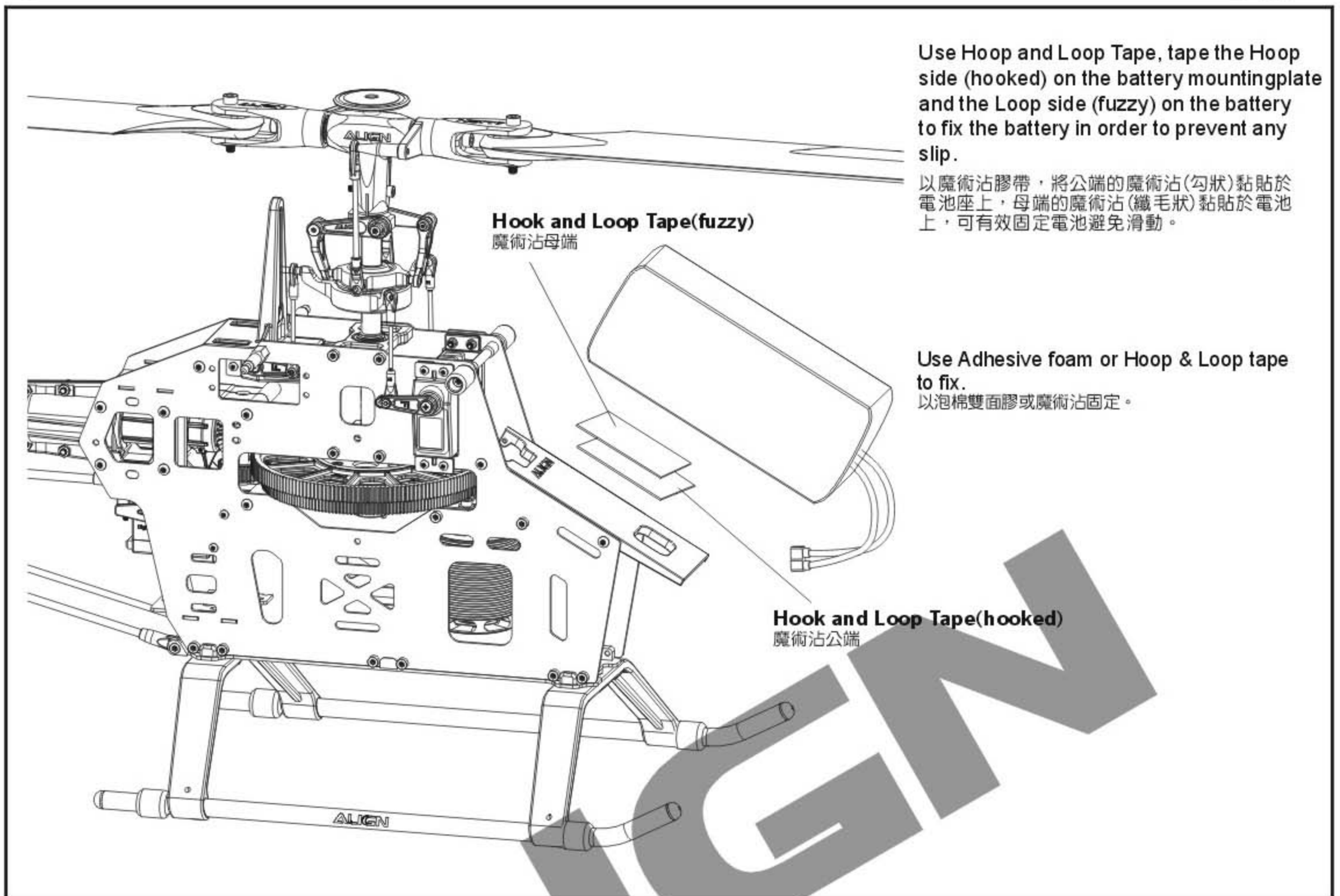

CAUTION
注意

1. Consult the following diagram for 3GX installation direction, with arrow pointing toward **nose** or **tail** of helicopter. 3GX needs to be mounted **flat** on gyro mounting platform, away from vibration sources.
2. Two pieces of foam mounting tape can be used if helicopter experiences vibration induced flight instability. However, if this still doesn't cure the problem, please check the helicopter mechanics and minimize mechanical vibrations, or reduce the headspeed.
3. Please secure with genuine factory issued double sided anti-vibration mounting tape.

1. 3GX擺放方向請參照圖示，方向指示箭頭指向機頭或機尾，水平擺放於陀螺儀固定座，並避開震動源。
2. 機體震動會影響陀螺儀偵測，造成飛行不穩定，可於3GX下方貼附2片泡棉減震，若仍未改善，請檢查機體排除震動或降低主旋翼轉速。
3. 請使用原廠提供避震泡棉雙面膠固定。

Directional Arrow
方向指示

3GX Flybarless System
3GX無平衡翼系統

55HZ1

Canopy
機頭罩

Canopy nut
機頭罩固定套 x 2

Canopy protector
機頭罩墊片 x 2

55HZ1

When assembling the canopy to the unit, please completely wedge into the groove of the bottom plate.
機頭罩組裝於機體時，請完全卡入主體底板的溝槽內。

Socket button head self tapping screw
半圓頭內六角自攻螺絲
T3x6mm

To set this option is to turn on the transmitter and connect to BEC power.
此項設定只要開啓發射器，接上BEC電源即可進行操作。

JR Transmitter/Servo JR遙控器對應伺服器關係

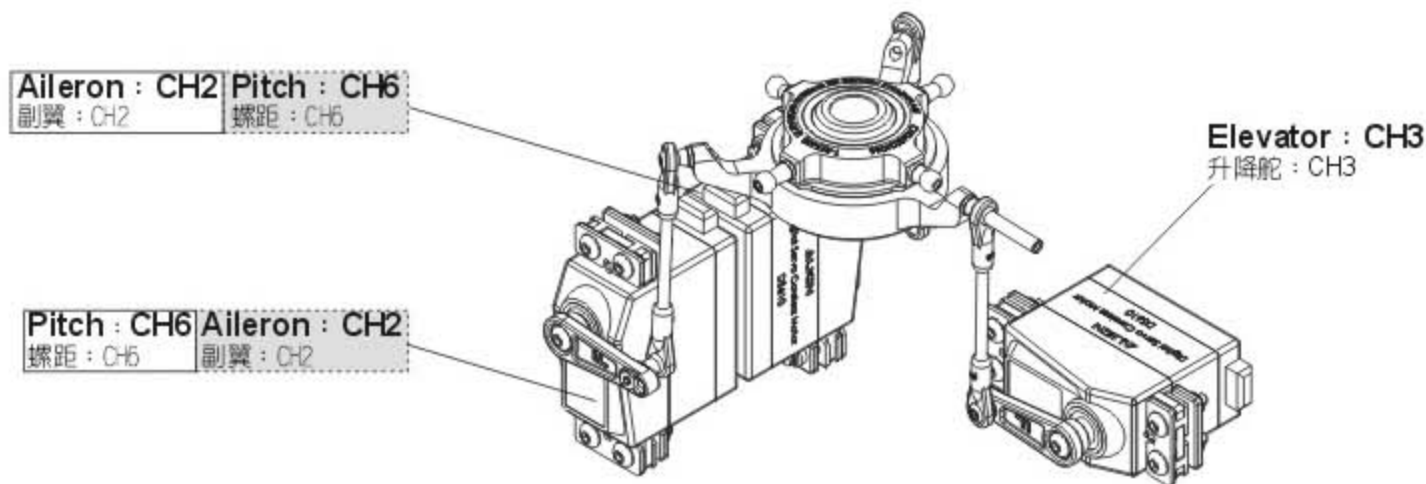

Positions of CH2 · CH6 are exchangeable, After assembling as photo (Note: Set the transmitter under CCPM 120 degrees mode), pull throttle stick (pitch) upward. If one swashplate servo (or two servos) moves downward, adjust reverse switch (REV) on the transmitter to make it moves upward. If three servo move downward, adjust the travel value (+) of SWASH CH6 on the transmitter to make them move upward. When the actions of Aileron and Elevator are opposite, adjust travel values of SWASH CH2 and CH3.

CH2 · CH6可互換配置，依圖連結後(注意：遙控器須設定於CCPM 120°十字盤模式)，將油門搖桿(Pitch)往上推，若十字盤伺服器有1個或2個往下移時，請調整遙控器的反轉開關(REV)使伺服器往上，若3個伺服器同時往下移時，請調整遙控器 SWASH CH6行程量的正負值，使伺服器同時往上平移，副翼與前後動作相反時，同樣調整 SWASH CH2 · CH3 行程量正負值。

FUTABA/HITEC Transmitter/Servo FUTABA/HITEC遙控器對應伺服器關係

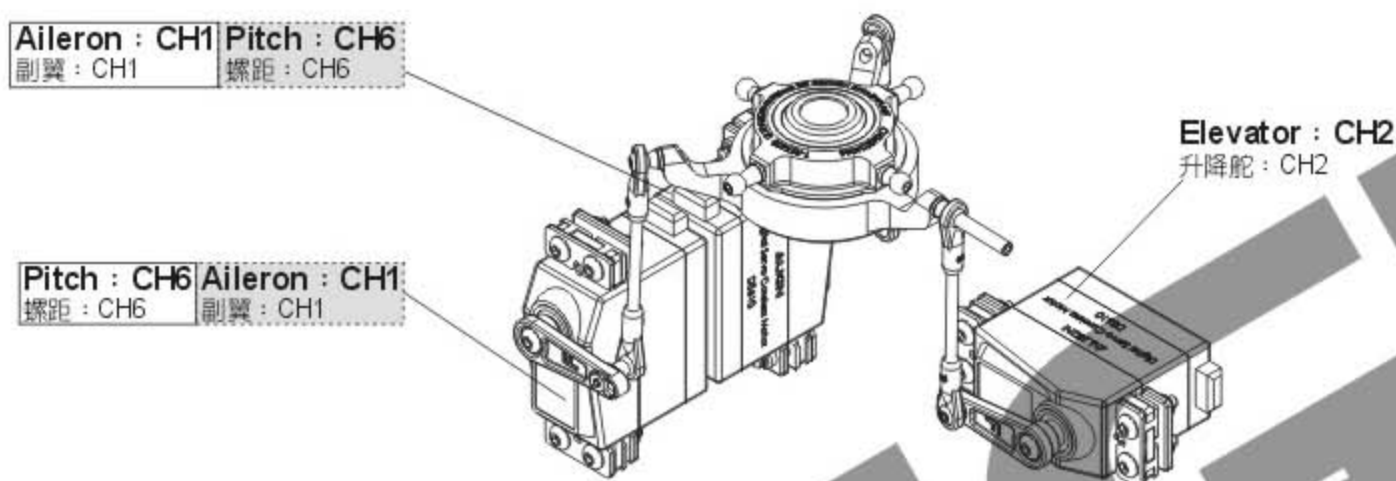

Positions of CH1 · CH6 are exchangeable, After assembling as photo (Note: Set the transmitter under CCPM 120 degrees mode), pull throttle stick (pitch) upward. If one swashplate servo (or two servos) moves downward, adjust reverse switch (REV) on the transmitter to make it moves upward. If three servo move downward, adjust the travel value (+) of SWASH CH6 on the transmitter to make them move upward. When the actions of Aileron and Elevator are opposite, adjust travel values of SWASH CH1 and CH2.

CH1 · CH6可互換配置，依圖連結後(注意：遙控器須設定於CCPM 120°十字盤模式)，將油門搖桿(Pitch)往上推，若十字盤伺服器有1個或2個往下移時，請調整遙控器的反轉開關(REV)使伺服器往上，若3個伺服器同時往下移時，請調整遙控器 SWASH CH6行程量的正負值，使伺服器同時往上平移，副翼與前後動作相反時，同樣調整 SWASH CH1 · CH2 行程量正負值。

12.AJUSTMENTS FOR GYRO AND TAIL NEUTRAL SETTING 陀螺儀與尾翼中立點設定調整

Turn off Revolution mixing(RVMX) mode on the transmitter, then set the gain switch on the transmitter and the gyro to Head lock mode. The gain setting is about 70%, and after transmitter setting, connect to BEC power to work on tail neutral setting.

Note : When turn on BEC power, please do not touch tail rudder stick and the helicopter. Then wait for 3 seconds, make tail servo arm and tail servo at a right angle(90 degrees), tail pitch assembly must be correctly fixed about in the middle of the travel of tail rotor shaft for standard neutral setting.

發射器內陀螺儀設定請關閉根軸混控模式，並將發射器上的感度開關與陀螺儀切至鎖定模式，感度設約 70% 左右，發射器設定完成後接上BEC接收電源，即可進行尾中立點設置。

注意：當啟動BEC電源時請勿撥動尾舵搖桿或碰觸機體，待3秒陀螺儀鎖定後尾伺服器需與尾伺服器約成90°，尾旋翼控制組須正確置於尾橫軸行程約中間位置，即為標準尾中立點設定。

TAIL NEUTRAL SETTING 尾中立點設定

After setting Head Lock mode, correct setting position of tail servo and tail pitch assembly is as photo. If the tail pitch assembly is not at the neutral position, please adjust the length of rudder control rod to trim.

陀螺儀鎖定後尾伺服器與尾 Pitch控制組正確擺置位置。若尾 Pitch控制組未置中時請調整尾控制連桿的長度來修正。

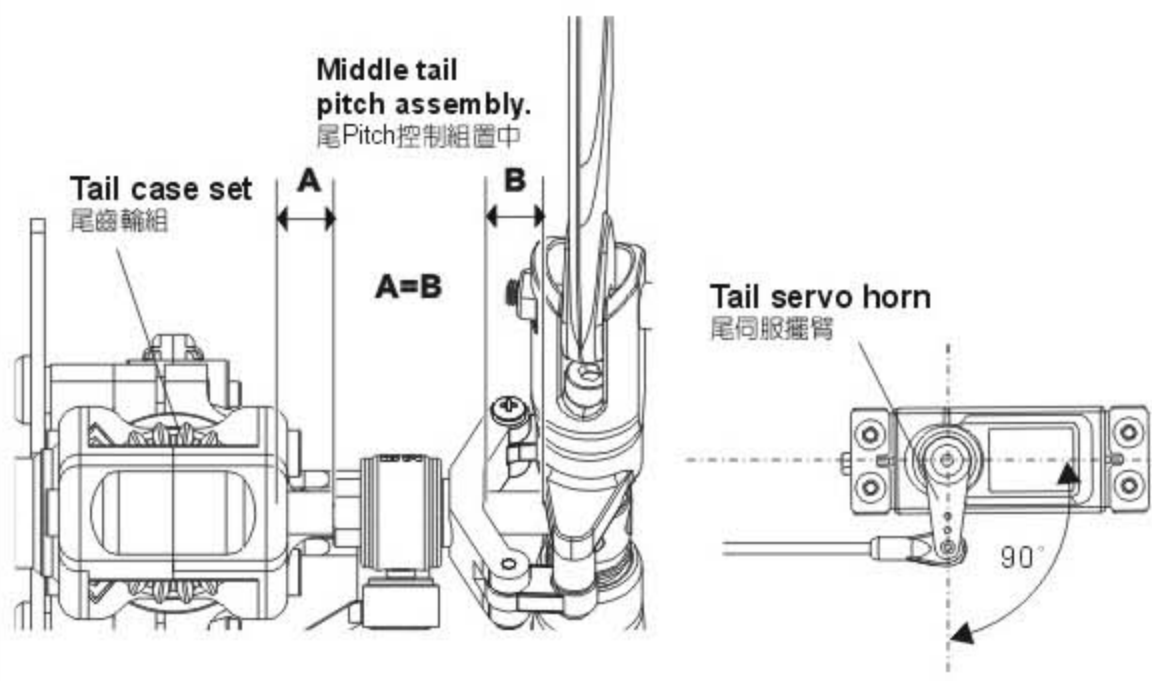

HEAD LOCK DIRECTION SETTING OF GYRO 陀螺儀鎖定方向設定

To check the head lock direction of gyro is to move the tail counterclockwise and the tail servo horn will be trimmed clockwise. If it trims in the reverse direction, please switch the gyro to "REVERSE".

陀螺儀鎖定方向確認，當手搖尾部逆時鐘擺動，尾伺服器擺臂應逆時鐘修正，反向時請切換陀螺儀上"鎖定反向"開關修正。

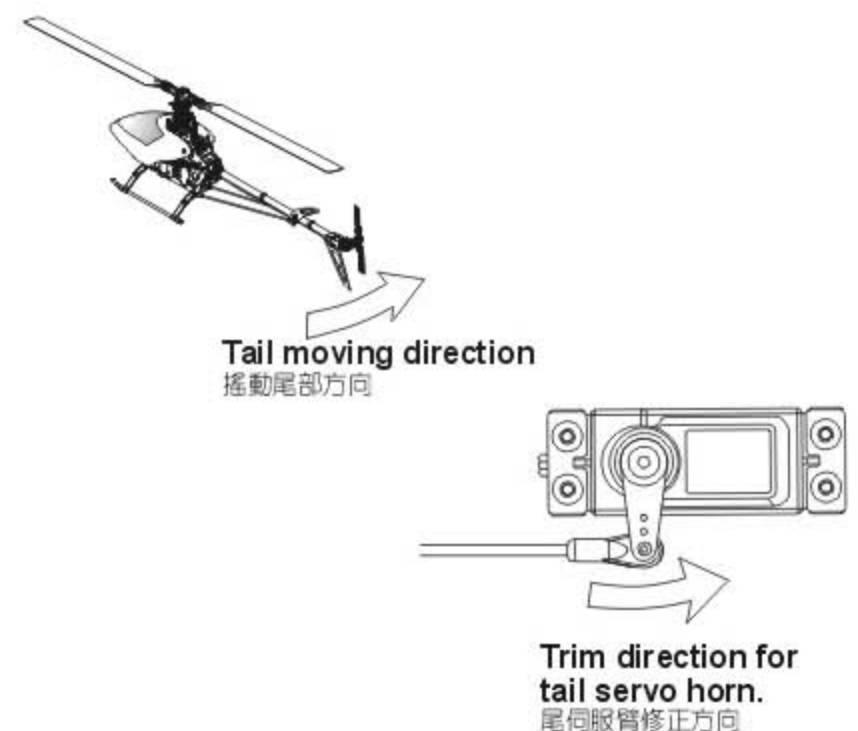

GENERAL FLIGHT 一般飛行模式

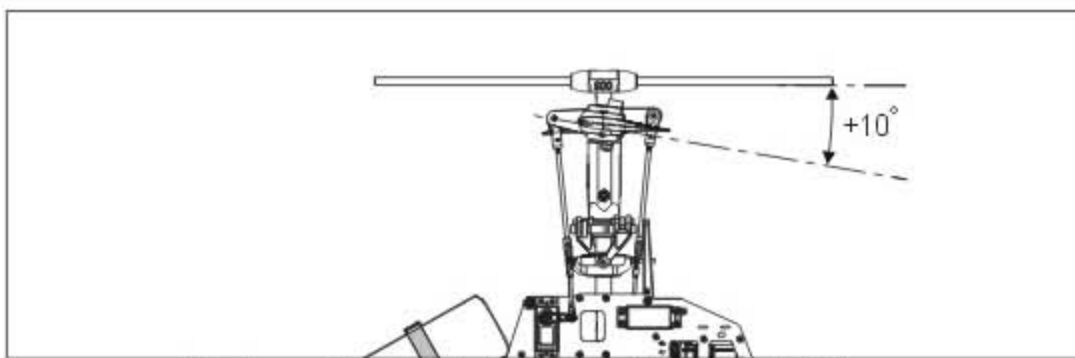

Stick position at high/Throttle 100%/Pitch+10°
搖桿高速/油門100%/Pitch+10°

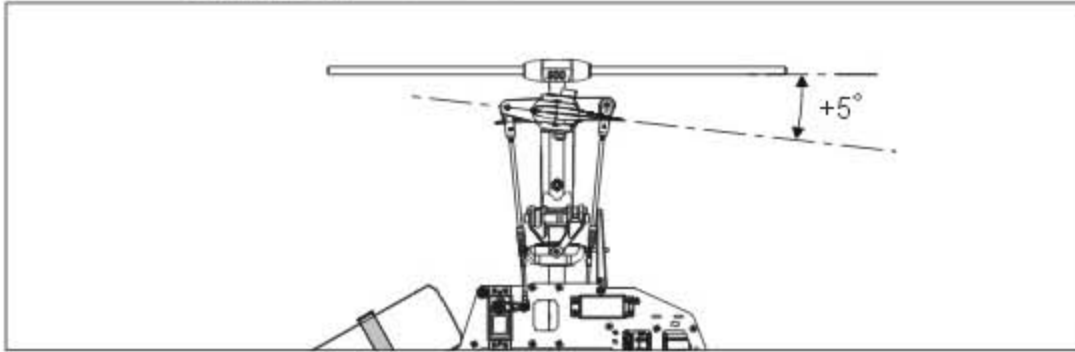

Stick position at Hovering/Throttle 60%/Pitch+5°
搖桿停懸/油門60%/Pitch+5°

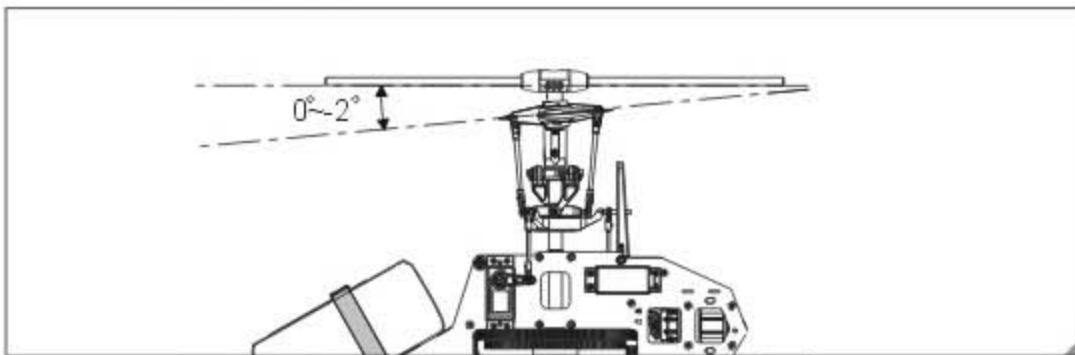

Stick position at low/Throttle 0%/Pitch0~-2°
搖桿低速/油門0%/Pitch0~-2°

GENERAL FLIGHT 一般飛行模式

	Throttle 油門	Pitch 螺距
5	100% High speed 100% 高速	+10°
4	85%	
3	60% Hovering 60% 停懸	+5°
2	40%	
1	0% Low speed 0% 低速	0° ~ -2°

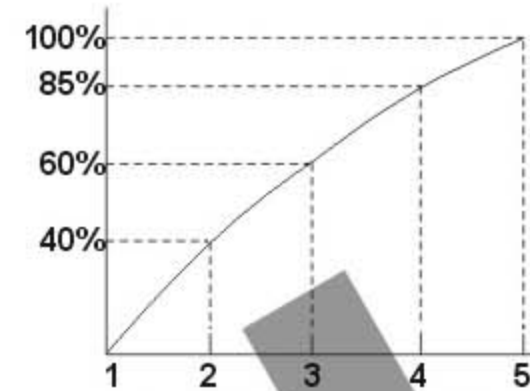

Throttle Curve (Hovering Flight)
停懸模式油門曲線

3D FLIGHT 3D特技飛行模式

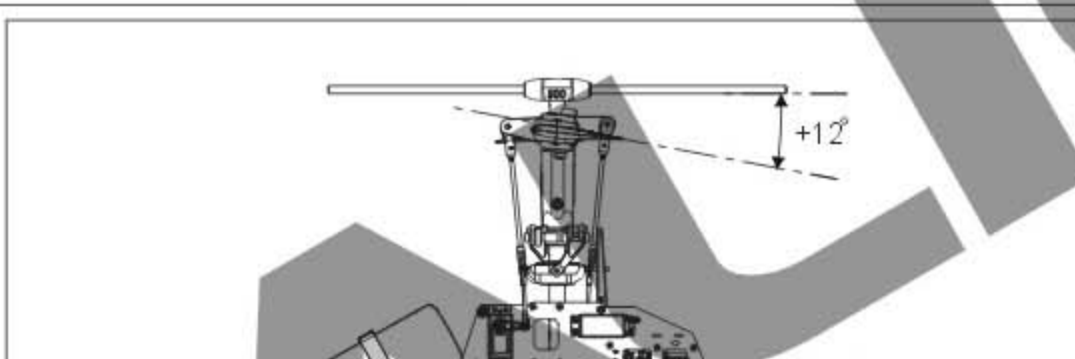

Stick position at high/Throttle 100%/Pitch+12°
搖桿高速/油門100%/Pitch+12°

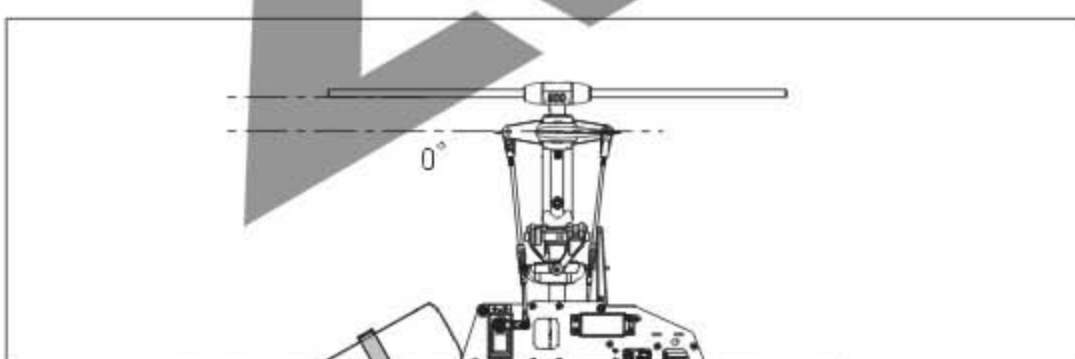

Stick position at middle/Throttle 90%/Pitch 0°
搖桿中速/油門90%/Pitch 0°

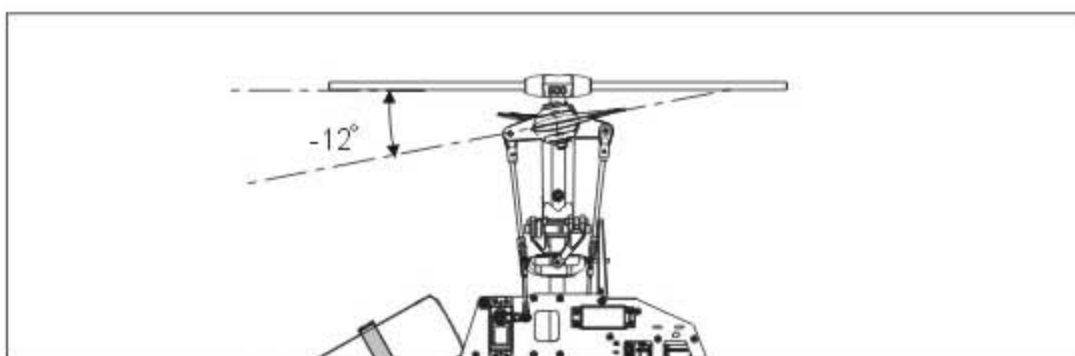

Stick position at low/Throttle 100%/Pitch-12°
搖桿低速/油門100%/Pitch-12°

IDLE 1 : SPORT FLIGHT

	Throttle 油門	Pitch 螺距
5	85%	+12°
3	80%	+5°
1	85%	-5°

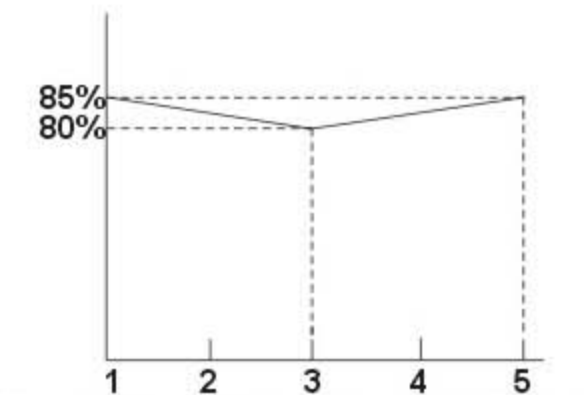

Throttle Curve (Simple Aerobatic Flight)
空中飛行模式油門曲線

IDLE 2 : 3D FLIGHT

	Throttle 油門	Pitch 螺距
5	100% High 100% 高	+12°
3	90% Middle 90% 中	0°
1	100% Low 100% 低	-12°

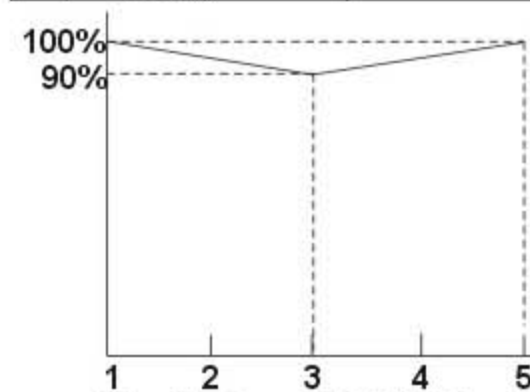

Throttle Curve (3D Flight)
特技飛行模式油門曲線



1. Pitch range : Approx. ±15 degrees.
2. If the pitch is set too high, it will result in shorter flight duration and poor motor performance.
3. Setting the throttle to provide a higher speed is preferable to increasing the pitch too high.
1. 螺距(Pitch)總行程約 ±15°
2. 過大螺距設定，會導致動力與飛行時間降低。
3. 動力提昇以較高轉速的設定方式，優於螺距調大的設定。

FEATURES 產品特色

- 3Axis** **3-axis gyroscopic flybarless system to simulate the stability of mechanical flybar system, yet at the same time achieving agile 3D performance.**
3軸陀螺儀無平衡翼系統，可模擬有平衡翼系統的穩定性，更有靈活的3D性能。
- MEMS** **Utilizes MEMS gyro sensors, which feature small footprint, high reliability, and excellent stability.**
採用MEMS (Micro Electro Mechanical Systems) 微機電系統技術感測器，具有體積小，可靠性高，穩定性佳的優點。
- 12bit** **12 bit processors providing ultra high resolution, resulting in highly precise controls.**
採用12位元處理器，超高解析度，控制細膩精準。
- SPEKTRUM/JR** **Supports Spektrum and JR satellite receivers.**
支援SPEKTRUM與JR衛星天線。
- S.BUS** **Supports Futaba S.Bus architecture.**
支援Futaba S.BUS功能。
- USB** **Software upgradable through PC interface adapter.**
具備可升級程式化介面，可透過傳輸線更新軟體。
- Easy** **Simplistic setup process without the need of external devices. Setup is done through 5 steps and 2 sensitivity adjustments. Rudder setup is identical to GP780 gyro, minimizing learning curve.**
設定簡單不需額外的介面，只需五個步驟、兩個感度調整即可完成所有設定，尾舵設定和GP780相同，設定輕鬆上手。
- Energy** **Flybarless system dramatically improves 3D power output and efficiency, resulting in reduced fuel or electricity consumption.**
無平衡翼系統，可大幅降低3D大動作飛行能量消耗，提供直昇機更大的動力輸出且更加節省燃油或電力。
- Stable** **Highly sensitive gyroscopic sensors combined with advanced control detection routine providing higher hovering and aerobatic stability than other flybarless system.**
高感度陀螺感測器及先進環路設計，可提供比一般平衡翼系統更佳的靜態及動態穩定性。
- CCPM** **Suitable for all CCPM and mechanical mixing system.**
適用於任何比例之對稱式三伺服器CCPM系統及傳統十字盤系統。
- GOV** **Built in speed governor function.**
內建定速器功能。
- T-REX 250-700** **Compatible with helicopter of all sizes from T-Rex 250 to T-Rex 700.**
3GX Flybarless電子設備相容迷你型直昇機至大型直昇機T-REX250~T-REX700。
- Pitch Gauge** **Innovative pitch gauge as an aid to facilitate pitch adjustments.**
創新設計的螺距量測器，藉以模擬有平衡翼系統之螺距量測。
- 280Hz** **High frame rate signal output for faster and higher precision servo response.**
高頻數位輸出訊號，使伺服器的反應更加精準、迅速。
- 3.5V-8.4V** **Capable to operate between 3.5V to 8.4V, compatible with high voltage servos.**
適用電壓3.5V~8.4V，支援高電壓伺服器。
- 11g** **Small footprint, light weight, minimalists and reliable design.**
體積小、重量輕，構造簡單可靠，提供操控者高性能的飛行樂趣。
- RoHS** **RoHS certified.**
符合RoHS限用規章。

3GX FLYBARLESS SETUP INDICATORS 功能設定指示燈說明

Flybarless system setup mode 無平衡翼系統設定模式：

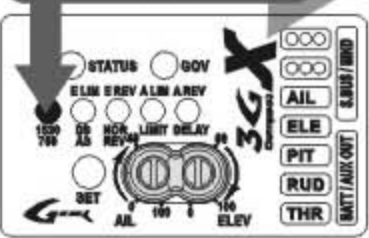
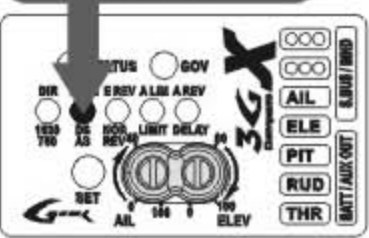
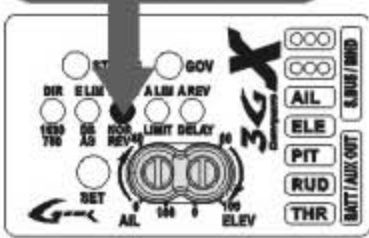
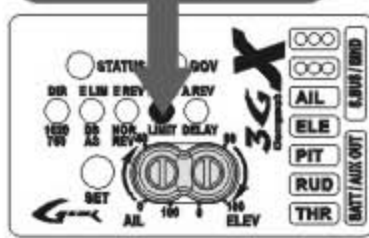
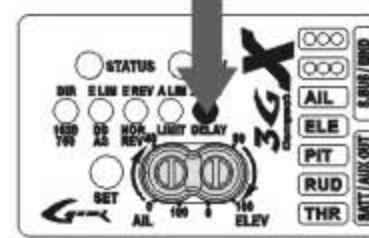
DIR	E.LIM	E.REV	A.LIM	A.REV
				
Direct mode bypassing gyro, for mechanical travel and neutral point setup. 機械行程與中立點設定	Collective mixing type recognition and elevator endpoint settings 混控辨識及升降舵行程設定	Elevator reverse settings 升降舵正反向設定	Aileron endpoints settings 副翼行程設定	Aileron reverse settings 副翼正反向設定

Rudder gyro setup mode 尾舵陀螺儀設定模式：

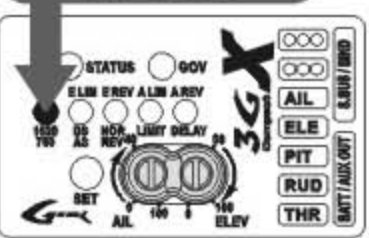
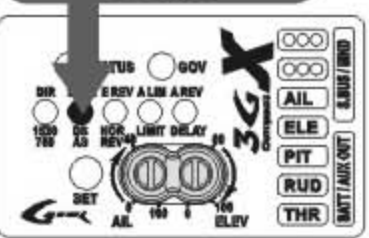
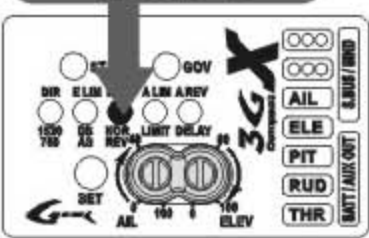
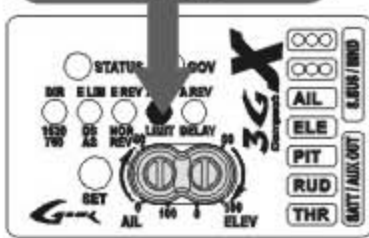
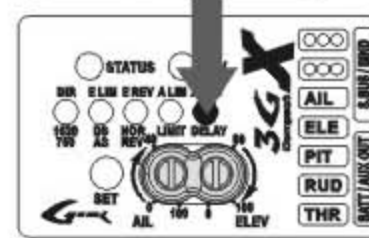
1520/760	DS/AS	NOR/REV	LIMIT	DELAY
				
Servo frame rate settings (1520 μs and 760 μs) 寬頻1520 μs及窄頻 760 μs 伺服器設定	Digital/Analog servo settings 數位及類比伺服器設定	Rudder Servo Reverse settings 尾舵陀螺儀正反向設定	Rudder endpoints settings 尾舵行程設定	Rudder servo delay, and helicopter size settings 尾舵延遲量及大小直昇機模式設定

SETUP PRE-CHECK 設定前注意事項



While using 3GX FBL system, be sure to turn off the following functions in the transmitter
 使用3GX系統若是遙控器有下列功能時請勿開啓功能
 * Swash Ring * Linkage Compensation * Swash Mix * Mixing * Acceleration

1. Connect the receiver and servos to the flybarless control unit as per diagram found on page 21~22 .
 2. Digital servos must be used on cyclic to avoid damage to servos.
 commended servo spec: minimum speed 0.08 sec/60, torque 12kg.cm or higher.
 3. The trim must be zero when using 3GX, and should not be adjusted at anytime. If the helicopter hovering tend one side, it means the swashplate doesn't keep horizontal when setting. Go to flybarless system "Direct mode bypassing gyro, for mechanical travel and neutral point setup" to adjust the level of the swashplate and then re-complete the setup.
 4. When the 3GX flybarless system is installed for the first time, a few simple setup steps and fly tests need to be performed in the flybarless setup mode. These steps need to be performed only during initial setup, and does not need to be repeated for subsequent flights. Just power up the system normally, check the proper servo operations, and fly. The initial setup procedure only need to be repeated after software upgrade, pitch range reset, or subtrims are added in the transmitter.
1. 將接收器及伺服器依接線示意圖連接 (請參照第21~22頁)。
 2. 十字盤必須安裝數位伺服器, 否則會造成伺服器損毀。建議規格: 速度0.08秒/60° 以內; 扭力12kg.cm以上。
 3. 進入設定前必須將遙控器的外微調歸零, 飛行時不可調整外微調, 若直昇機停懸時偏向某一邊移動, 表示設定時十字盤未保持水平, 請進入無平衡翼系統"機械行程與中立點設定", 調整十字盤呈水平後, 重新完成設定。
 4. 第一次安裝3GX Flybarless無平衡翼系統時, 必須進入無平衡翼設定模式, 進行幾項簡易的安裝設定與飛行測試, 完成後即不須再進入此設定模式, 只要正常開機, 檢查伺服器動作 正確後即可飛行; 除非要更新程式、重設螺距或有更動遙控器內微調(sub.trim)時, 必須進入設定模式重設無平衡翼系統。

3GX Connectivity Method 3GX接線方式

Method 1: Standard receiver connectivity method 方式一:傳統接收器接線法

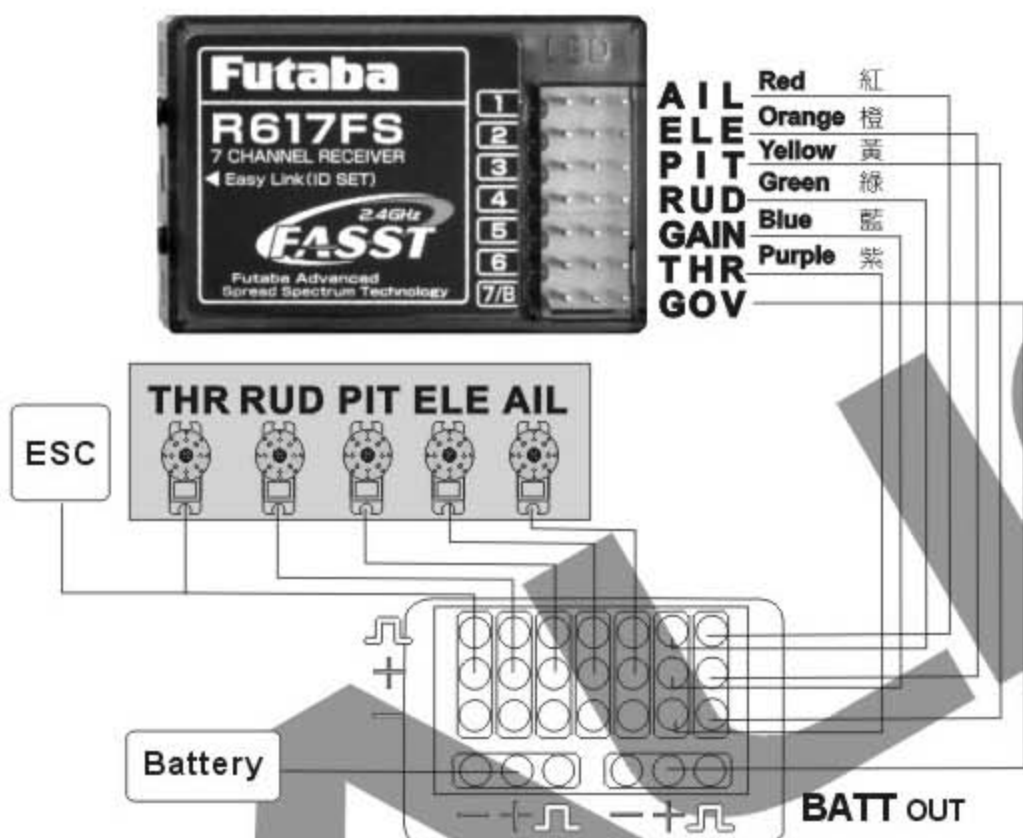

1. Connect all wires as shown in diagram. Receiver and 3GX wires are color coded to distinguish the different connection channels. Care should be taken to ensure proper wire color to channel connection.
 2. Receiver power is achieved by connecting the 3GX "S.BUS/BIND" port to the ch7 or BATT port on receiver using supplied signal wire.
 3. To avoid damage to servos, only digital servos should be used for swashplate. Recommended spec: 0.08s/60° or faster, with 12 Kg or higher torque.
 4. 3GX has built in speed governor function which can be utilized by purchasing the optional speed sensor. Governor setting is done through channel 7 on the receiver.
1. 請依照圖示進行接線, 接收器與3GX的接線使用不同的顏色來區分不同的通道, 接線時請注意各顏色所對應的通道。
 2. 接收器電源請以隨附的訊號線由3GX的"S.BUS/BIND"孔位接至第七通道或BATT通道。
 3. 十字盤必須安裝數位伺服器, 否則會造成伺服器損毀。建議規格: 速度0.08秒/60°以內; 扭力12kg以上。
 4. 3GX內建定速器功能, 可另購定速器感知器使用, 轉速設定由接收器的第七通道設定。

Method 2: Futaba S.BUS Connectivity method 方式二:Futaba S.BUS接線法

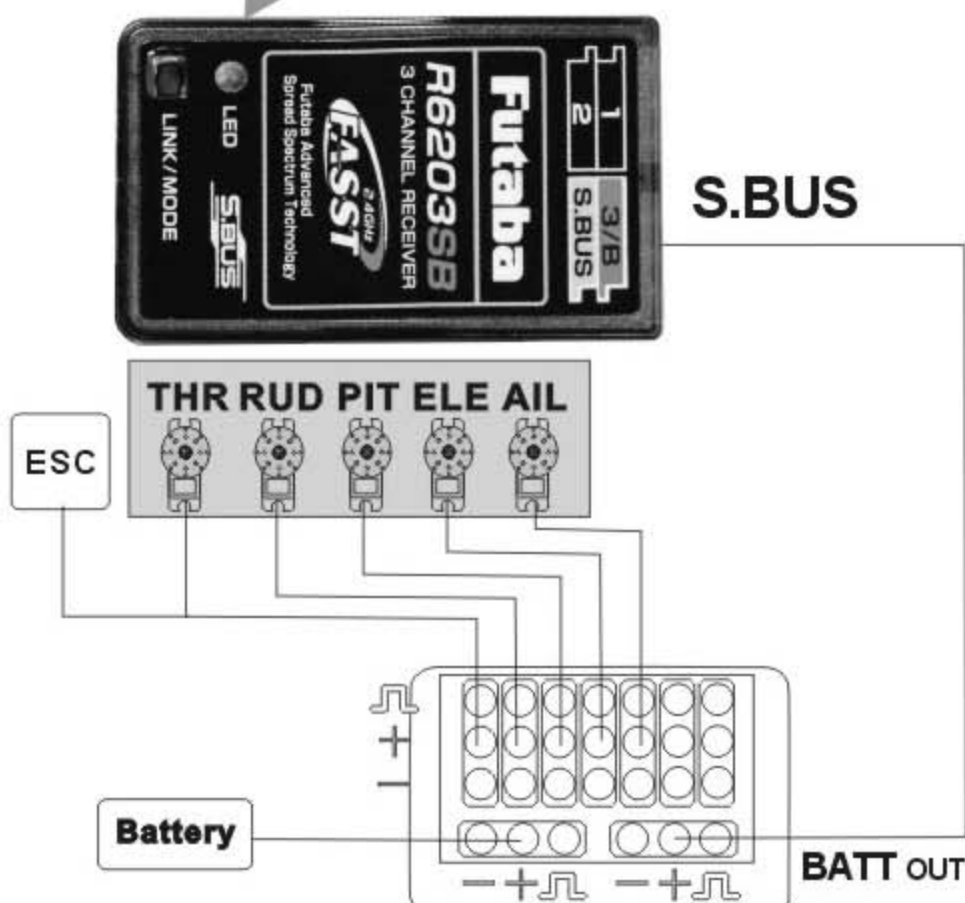

1. For Futaba S.BUS receivers, connect wires as shown in diagram.
 2. Receiver power is supplied through S.BUS signal wire connected to 3GX' s "S.BUS/BIND" port.
 3. The default channel/function mapping when using S.BUS are:
 (1)AIL (2)ELE (3)THR
 (4)RUD (5)GAIN (6)PIT (7)GOV
1. 具備S.BUS功能的Futaba接收器, 請依照圖示進行接線。
 2. 接收器電源共同由S.BUS 訊號線接至3GX的"S.BUS/BIND"孔位。
 3. 使用S.BUS功能時, 內部通道已指定為:
 (1) AIL (2) ELE (3) THR
 (4) RUD (5) GAIN (6) PIT (7) GOV



If channel 3 is set as PIT and channel 6 set as THR on transmitter, Such as 8FG, 12Z, 14MZ,nd etc, please reprogram the transmitter to utilize channel3 as THR and channel6 as PIT.
 若所使用的遙控器內部指定(3)通道為PIT (6)通道為THR時, 例如8FG、12Z、14MZ等, 請更改遙控器上的設定為(3)通道 THR (6)通道 PIT。

4. To avoid damage to servos, only digital servos should be used for swashplate. Recommended spec: 0.08s/60 or faster, with 12Kg or higher torque.
 5. 3GX has built in speed governor function which can be utilized by purchasing the optional speed sensor. Governor setting is done through channel 7 on the receiver.
4. 十字盤必須安裝數位伺服器, 否則會造成伺服器損毀。建議規格: 速度0.08秒/60°以內; 扭力12kg以上。
 5. 3GX內建定速器功能, 可另購定速器感知器使用, 轉速設定由接收器的第七通道設定。

Method 3: JR/SPEKTRUM Satellite connectivity method 方式三:JR/SPEKTRUM衛星天線接線法

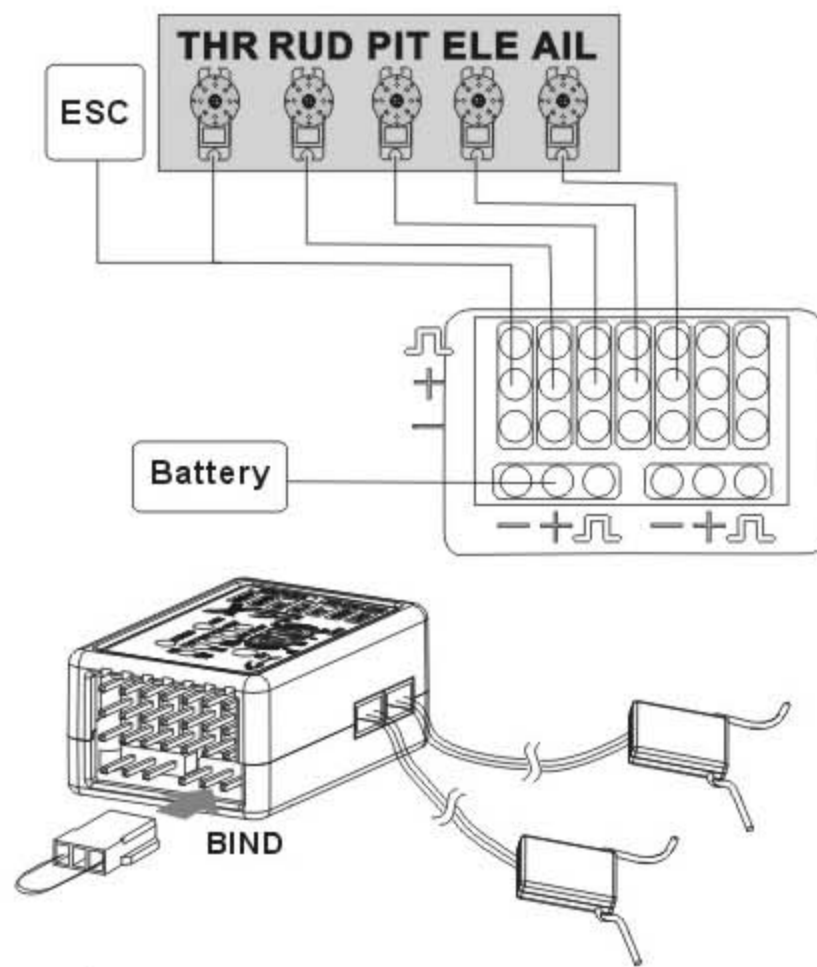

1. Do not mix satellite receivers of different makes.
2. Even under correct startup sequence, if transmitter is powered off first, LED1~LED5 will also flash. Thus the receiver should always be powered off before the transmitter.
3. 3GX supports satellite receiver models currently available on the market. Should new receiver version comes out with compatibility issues, firmware will be updated to resolve any incompatibility that may arise.

1. 不同廠牌的衛星天線請勿交叉對頻。
2. 正常開機的情況下，如果先關發射機，也會發生LED1~LED5持續閃爍情況，所以請養成先關接收機，再關發射機的良好習慣。
3. 如有新型號衛星天線產生不相容情形，將以韌體更新方式解決。

1. For JR or Spektrum satellite receivers, connect wires as shown in diagram.
2. To avoid damage to servos, only digital servos should be used for swashplate. Recommended spec: 0.08s/60° or faster, with 12Kg or higher torque.
3. 3GX has built in speed governor function which can be utilized by purchasing the optional speed sensor. Governor setting is done through channel 7 on the receiver. Channel 5/GEAR controls RPM of speed governor, channel 7/AUX2 controls rudder gyro gain. For radios with less than 6 channels, please use the standard receiver connectivity method.
4. For radios with less than 6 channels, channel 5/GEAR is used for rudder gyro gain. Speed governor cannot be used. For safety concern, two satellite receives should be used, with each antenna perpendicular (90 degrees) from each other. A satellite receiver should be installed on each side of the frame, separate by minimum distance of 5cm.
5. Should both satellite receivers loose connectivity during flight, LED1 ~ LED5 will flash continuously as warning. A single power cycle of the system will not clear this error. The system need to be power cycled the second time to reset.
6. default channel/function mapping when using satellite receiver are:
 (1)THR (2)AIL (3)ELE
 (4)RUD (5)GOV (6)PIT (7)GAIN

1. 請依照圖示進行接線，3GX支援Spektrum與JR系統衛星天線。
2. 十字盤必須安裝數位伺服器，否則會造成伺服器損毀。
建議規格：速度0.08秒/60°以內；扭力12kg以上。
3. 3GX內建定速器功能，可另購定速器感知器使用。七動及七動以上遙控器(5) GEAR控制定速器轉速，(7) AUX2控制尾舵陀螺儀感度。六動以下遙控器請使用傳統接線方式。
4. 為安全起見，請盡量安裝兩個衛星天線，兩個衛星天線角度除必須呈90度之外，且須安裝於機身兩側，相隔至少5公分以上。
5. 如果飛行途中有兩個衛星天線同時失連的情形，LED1~LED5會持續閃爍警告，在此情形下就算重新開機，LED1~LED5會持續閃爍而無法開機，必須再重新開機一次，才可正常運作。
6. 使用衛星天線接線時，內部通道已指定為：
 (1) THR (2) AIL (3) ELE
 (4) RUD (5) GOV (6) PIT (7) GAIN

Failsafe(Last Position Hold) 失控保護(保留最後指令)：

When helicopter lost connectivity with your radio under this setting, all channels will hold at the last command position, except throttle channel which goes to a preset position.

1. Push throttle stick to the desired fail safe position.
2. Plug the binding plug into 3GX' s BIND port, and perform radio binding steps.
3. After successful binding, do not power off the 3GX, unplug the binding plug and allow 3GX to enter initializing process. The last position hold function will be active after the 3GX initializes.
4. Test Method: Power off transmitter. The throttle channel should move to preset position, while all other channels should hold in their last position.

在此模式下，若您的直昇機與遙控器失連，除油門頻道為預設位置，其餘頻道皆為最後指令位置。

1. 將油門搖桿放置於您所需要的預設安全位置
2. 將對頻接頭插在3GX的BIND插座，執行與遙控器的對頻動作。
3. 與遙控器完成對頻動作後，不要關閉3GX電源，先將對頻接頭拔除，3GX會進入開機狀態，待3GX開機完成後，即完成保留最後指令設定。
4. 測試方法：將遙控器關機，除了油門頻道為預設安全位置外，其餘頻道都為失連前的最後指令位置。

Failsafe (Pre-set Position Hold) 失控保護(回復預設值)：

When helicopter lost connectivity with your radio under this setting, all channels will move to the pre-set position.

1. Plug the binding plug into 3GX' s BIND port, and power up the 3GX. After the rapid flash of satellite' s LEDs, pull the binding plug off.
2. Power up radio transmitter, and perform radio binding steps. After radio is bound, LED on the satellite antennas will end the rapid flash, following by slower flash.
3. Move the transmitter sticks to the desired fail safe position while the LED is flashing in slower mode.
4. Satellite antenna' s LED will lit up after 5 seconds, and 3GX goes through initializing process. The failsafe position will be set after the 3GX initializes.
5. Test Method: Power off transmitter, and all channels should move to the pre-set failsafe position.

在此模式下，若您的直昇機與遙控器失連，所有頻道為預設安全位置。

1. 將對頻接頭插在3GX的BIND插座，先開啟3GX電源，待衛星天線上LED快速閃爍後，將對頻接頭拔除。
2. 開啟遙控器電源，執行與遙控器的對頻動作，對頻完成瞬間，衛星天線上LED會由快速閃爍狀態熄滅，之後再亮起改為慢速閃爍。
3. 在慢速閃爍狀態時，將遙控器上的所有搖桿放置於您所需要的預設安全位置。
4. 5秒後衛星天線LED燈為恆亮，3GX進入開機狀態，待3GX開機完成後，即完成失控保護設定。
5. 測試方法：將遙控器關機，所有頻道為預設安全位置。

FLYBARLESS SYSTEM INITIAL SETUP STEPS 無平衡翼系統設定

1. DIR : Direct mode to bypass gyro for mechanical travel and neutral point setup

DIR機械行程與中立點設定模式

Setup method for 3GX flybarless system is same as the 3G flybarless system. 3GX無平衡翼系統設定方式與3G相同

Step 1.1 : Enter the DIR settings 步驟 1.1 : 進入DIR設定

Press and hold the SET button while powering up the receiver. Release the button when LED 1-5 begin to cycle. The DIR green LED will light up indicating the gyro has been bypassed for neutral and mechanical travel range setup.

按下"SET"鍵不放，並將電池接上電子調速器ESC，接著LED1~5(DIR~A. REV)會循序亮起，此時即可以放開按鍵，"DIR"綠燈亮起，則進入3GX Flybarless機械行程與中立點設定模式。

Note: if pressed for more than 2 seconds, 3GX will enter governor setup mode.

註:若按壓時間超過2秒，3GX會進入定速器設定模式，請重開電源進入DIR設定。

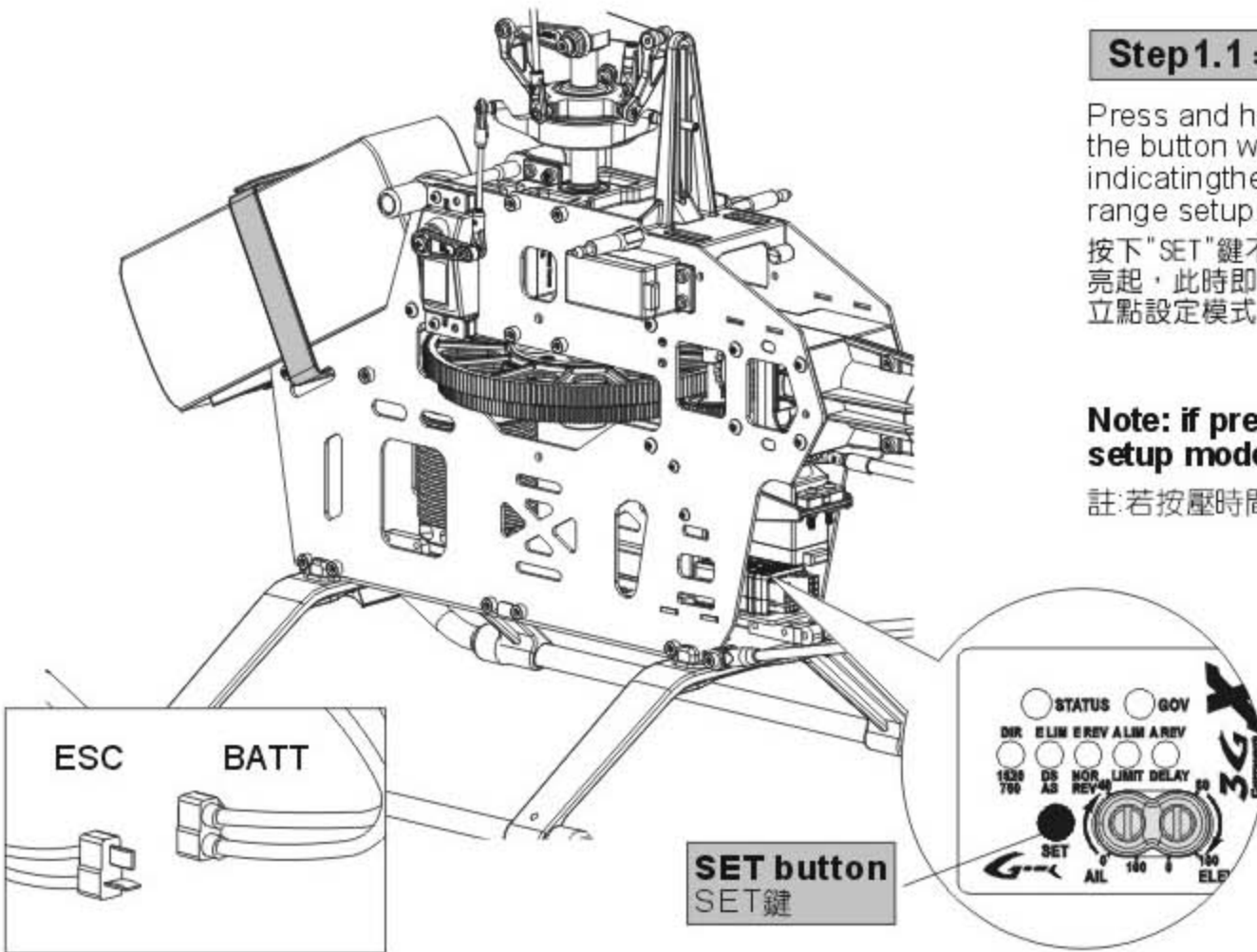

Transmitter function to servo mapping 遙控器對應伺服器關係

Step 1.2 : Swashplate function check 步驟 2 : 十字盤作動確認

Verify the correct swashplate movements for PIT, AIL, and ELE inputs. 確認十字盤作動 PIT、AIL、ELE 是否正確。

CAUTION 注意

In case of incorrect servo movement or no movement at all, please check for proper connection between 3GX flybarless connection to servos, as well as proper setup on transmitter.

若作動錯誤或伺服器無動作，請檢查3GX Flybarless 伺服器訊號線接線以及遙控器設定是否正確。

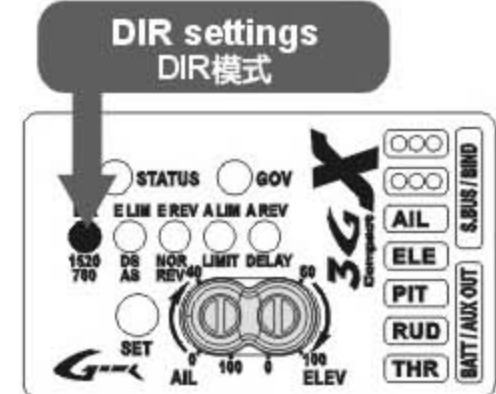
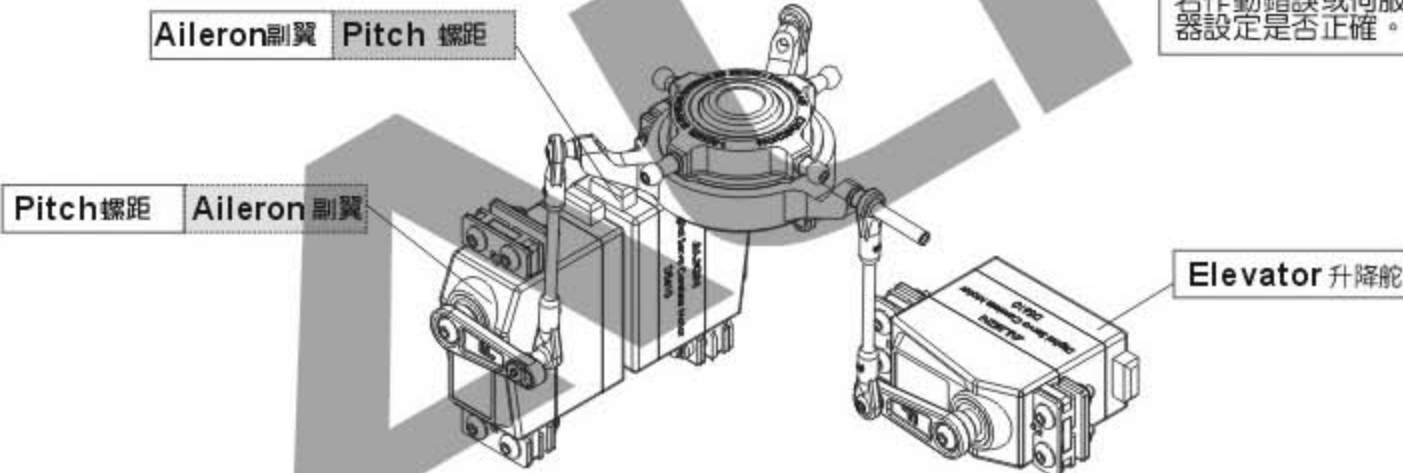

Step 1.3 : Mechanical Setup 步驟 1.3 : 機械結構設定

Adjust the servo neutral point and main blade pitch. 請調整伺服器中立點、主旋翼角度(如圖示)。

CAUTION 注意

Pay extra attention to these setup steps. Incorrect neutral points will affect flight stability, and worse lead to loss of control.

本步驟請確實設定，若中立點不正確，不但影響飛行穩定性，更可能造成失控的危險。

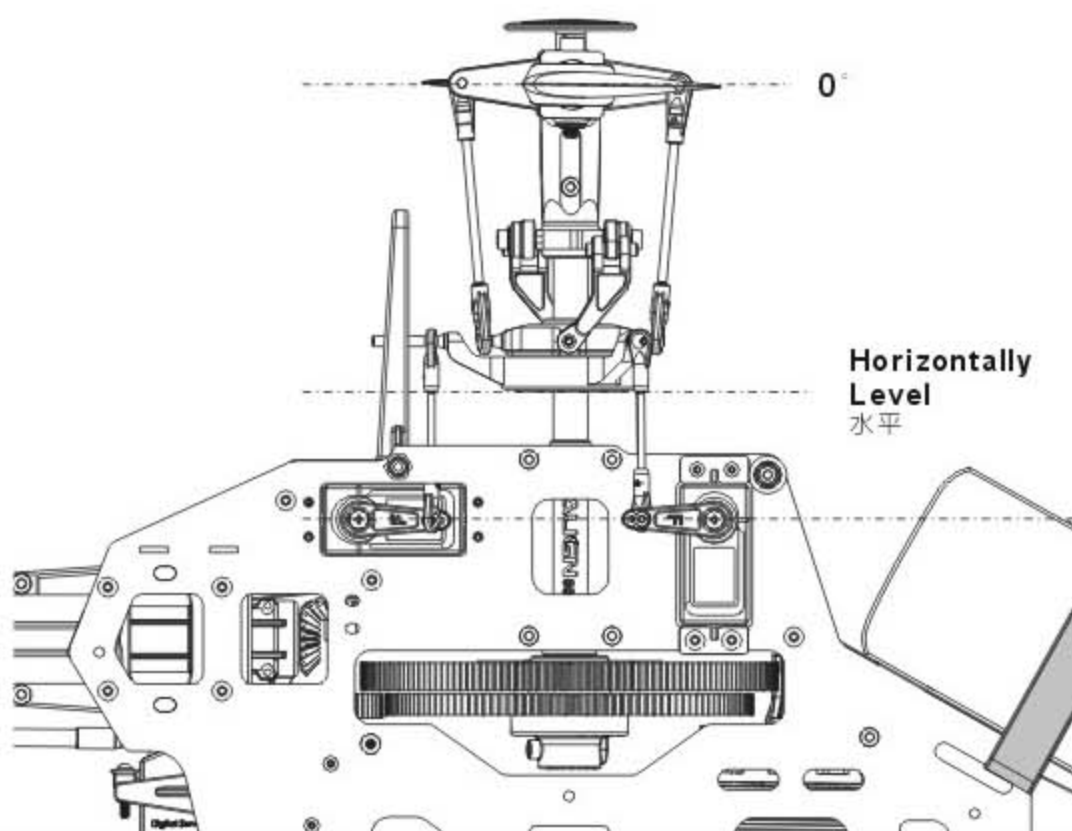

Adjust subtrims on transmitter so servo horn is horizontally level 伺服器中立點水平(Subtrim)

Step 1.4 : Collective pitch setup 步驟1.4 : 主旋翼螺距(集體螺距)設定

Adjust the maximum collective pitch using the transmitter's swashplate mixing function (pitch swash AFR). Recommended pitch range $\pm 12^\circ$, maximum pitch range for advanced pilot shall not exceed $\pm 14^\circ$. 建議螺距設定 $\pm 12^\circ$ ，高階使用者不超過 $\pm 14^\circ$ 為限。

CAUTION 注意

Do not adjust individual servos endpoints through the servo ATV/AFR function, use only swashplate mixing adjustments. Should any changes made to the endpoints or subtrims on the transmitter in the future, the flybarless system initial setup must be performed again. CCPM系統調整行程量時，須從遙控器Swash十字盤混控比率 (Pitch swash AFR) 調整，勿去調整個別伺服器的ATV行程量。爾後遙控器的內微調如有變更，必須重新進行Flybarless各項設定。

While using 3GX FBL system, be sure to turn off the following functions in the transmitter 使用3GX系統若是遙控器有下列功能時請勿開啓功能

- * Swash Ring
- * Linkage Compensation
- * Swash Mix
- * Mixing
- * Acceleration

Use the included pitch gauge and the gauge measuring rod to aid the adjustment of pitch. 利用隨附的螺距量測器與螺距量測桿，模擬有平衡翼系統之螺距量測。

Step 1.5 : Cyclic pitch setup 步驟1.5 : 循環螺距設定

Maximum cyclic pitch setup: With main blade parallel to helicopter body, move the transmitter aileron stick all the way left, and adjust the AIL mixing percentage in SWASH settings until main blade pitch are 12 to 14 degrees. Please refer to "SETUP EXAMPLES" on page 38. 十字盤循環螺距最大角度設定：主旋翼方向與機體方向相同，油門搖桿置於主旋翼角度0度的位置不動，撥動副翼搖桿至最左，調整遙控器Swash中AIL比率，使主旋翼的攻角為原廠建議值 $\pm 12^\circ$ ，並請參閱38頁「飛行特性對照表」。

CAUTION 注意

Adjustments to the CCPM servos endpoints should be done through transmitter's swashplate mixing function (AIL swash AFR). Do not adjust individual servos endpoints through the servo ATV/AFR function. Should any changes made to the endpoints or subtrims on the transmitter in the future, the flybarless system initial setup must be performed again. CCPM系統調整行程量時，從遙控器Swash十字盤混控比率做調整，勿去調整個別伺服器的ATV行程量。爾後遙控器內微調如有變更，必須重新進行Flybarless各項設定。

Example: cyclic pitch of 12' : Futaba 12ZH with three DS610's
 Aileron swash AFR : 65% (12')
 Elevator swash AFR : 65%
 Pitch swash AFR : 43% ($\pm 12'$)

以循環螺距設定12'為例：
 Futaba 12ZH 搭配 DS610 x 3
 Aileron swash AFR : 65% (12')
 Elevator swash AFR : 65%
 Pitch swash AFR : 43% ($\pm 12'$)

2.E.LIM swashplate mixing type recognition and elevator endpoint setup : E.LIM十字盤混控辨識及升降舵行程量設定模式 :

Step 2.1 : Entering E.LIM setup mode 步驟2.1 : 進入E.LIM設定

While keeping swashplate level and main pitch at zero degrees, press the SET button to register the neutral point and enter E.LIM setup mode. The E.LIM LED will lit up after DIR turns off.

保持十字盤為水平、旋翼角度為零度的狀態下，接著按下"SET"鍵DIR燈將熄滅，E.LIM燈將會亮起，進入"E.LIM升降舵行程量"設定模式。

CAUTION 注意

The throttle stick position where main pitch is 0 degree must be maintained through this setup process. 油門搖桿須置於主旋翼角度0度的位置，不可再移動。

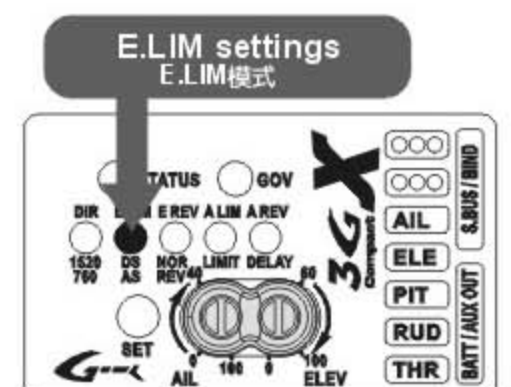
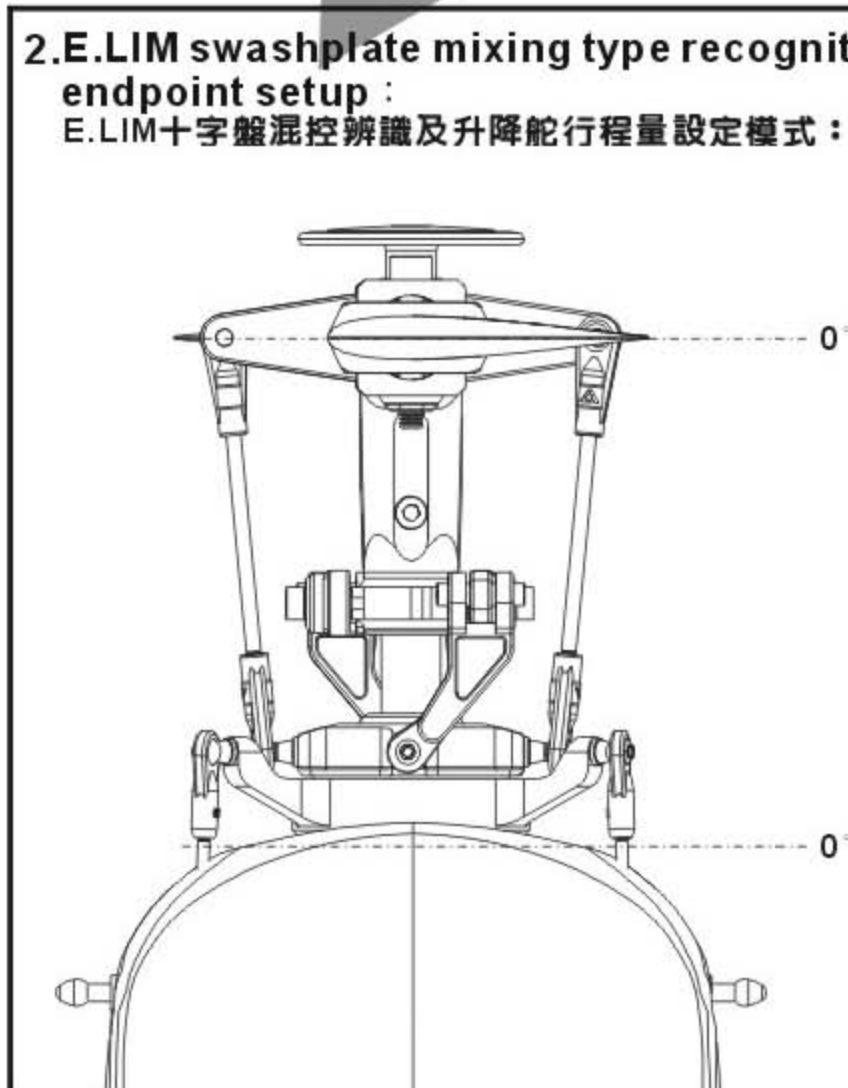

Step 2.2 : Swashplate mixing type recognition and elevator endpoint setup

步驟 2.2 : 十字盤混控辨識與升降舵行程量設定

With all channels stationary, move the transmitter elevator stick forward, and then back to center position. This completes the swashplate mixing type recognition process. The control unit will determine the CCPM mixing ratio or traditional mechanical mixing maximum elevator endpoints. 將遙控器升降舵推至最前方(請勿動到其他舵面動作), 再將升降舵搖桿放回中間位置, 完成此模式設定。

讓 3GX Flybarless 解算 CCPM 混控比例或傳統十字盤模式及前後可用行程。

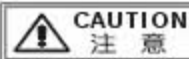

Throttle stick position where main pitch is 0 degree must be maintained through this setup process.
油門搖桿須置於主旋翼角度 0 度的位置, 不可再移動。

Throttle stick must be maintained
油門搖桿固定

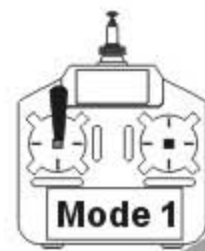

ELE

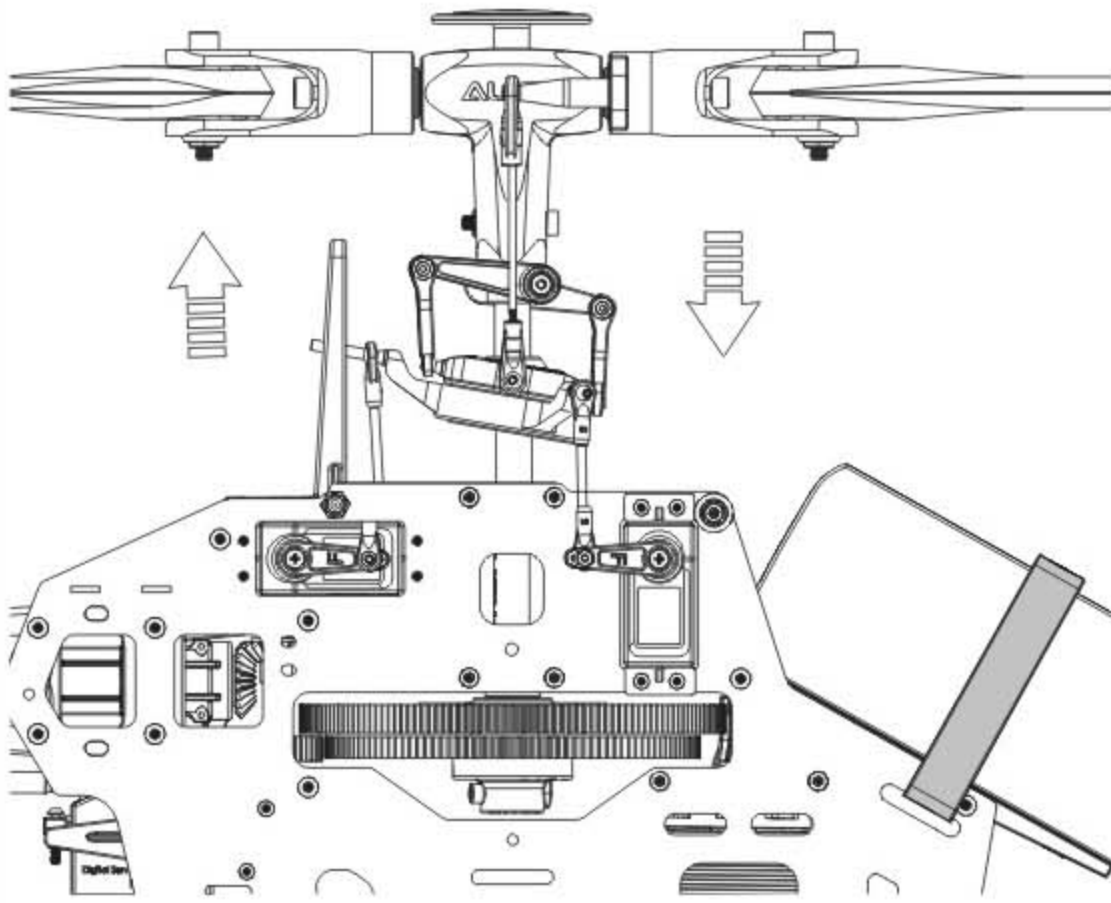
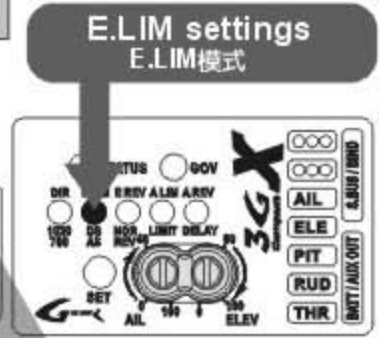
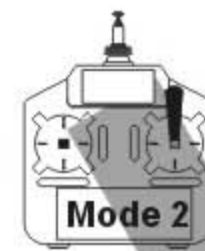

3. E.REV elevator reverse setup mode : E.REV 升降舵陀螺儀正反向設定模式 :

Press the SET button to enter E.REV setup mode. The E.REV LED will lit up after E.LIM turns off. This setup mode sets the elevator gyro direction

1. Tilt the helicopter forward as shown in diagram, and check if swashplate is tilting correctly toward the back.
2. If the swashplate is tilting at the wrong direction, move the transmitter elevator stick until STATUS LED changes color, and re-check the swashplate tilting direction.

接著按下 "SET" 鍵, 讓設定模式進入 "E.REV 升降舵陀螺儀正反向" 設定模式, 此時 E.LIM 燈熄滅, E.REV 燈亮起。此模式設定升降舵陀螺儀修正方向

1. 如圖示, 將機身向前傾確認十字盤的修正方向是否正確。
2. 如果十字盤方向修正錯誤, 請撥動升降舵搖桿改變 STATUS 燈顏色後, 再次確認十字盤修正方向是否正確。

Swashplate correction direction
十字盤修正方向

Helicopter tilting direction
機體傾斜方向

Helicopter tilting direction
機體傾斜方向

E.REV settings
E.REV 模式

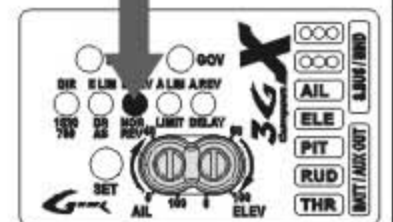

4. A.LIM aileron endpoints setup : A.LIM 副翼行程量設定模式 :

Press the SET button to enter A.LIM setup mode. The A.LIM LED will lit up after E.REV turns off. With all channels stationary, move the transmitter aileron stick to the right, and then back to center position. This completes the aileron endpoint setup process. The control unit will determine the maximum aileron endpoints

接著按下 "SET" 鍵, 讓設定模式進入 "A.LIM 副翼行程量" 設定模式, 此時 E.REV 燈熄滅, A.LIM 燈亮起。將副翼搖桿向右推到底, 完成後將搖桿置中, 完成此模式設定, 讓 3GX Flybarless 解算副翼可用行程。

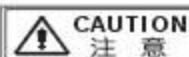

The throttle stick position where main pitch is 0 degree must be maintained through this setup process.
油門搖桿須置於主旋翼角度 0 度的位置, 不可再移動。

Throttle stick must be maintained
油門搖桿固定

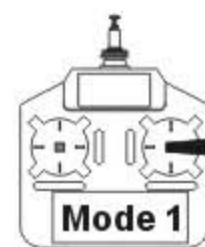

AIL

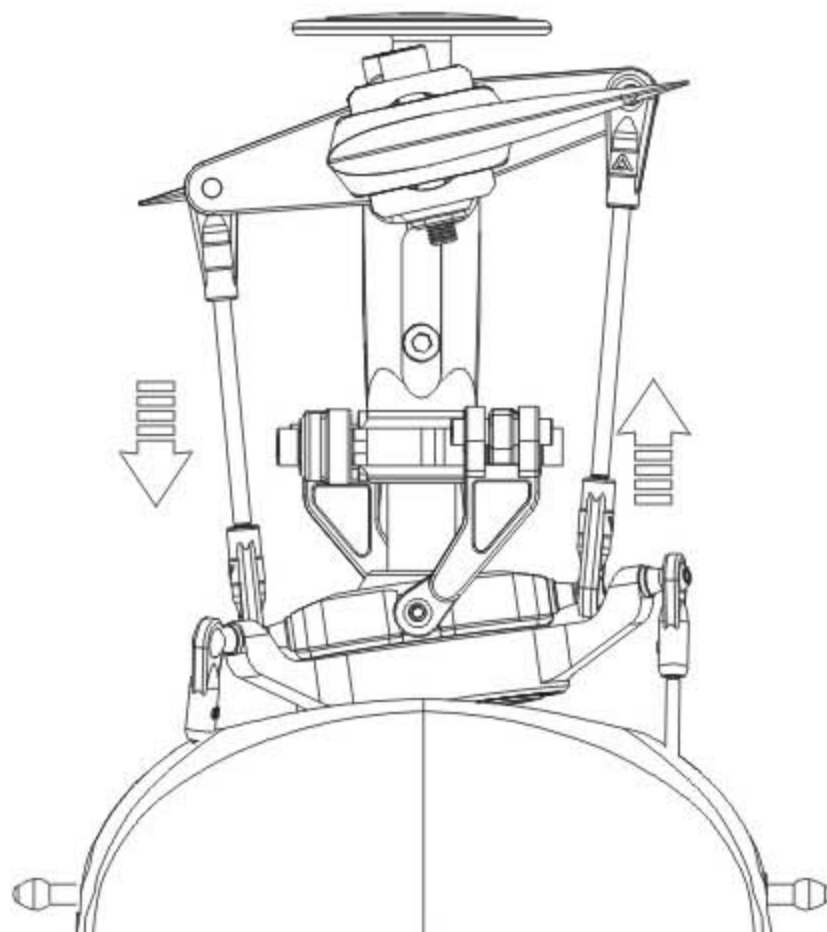
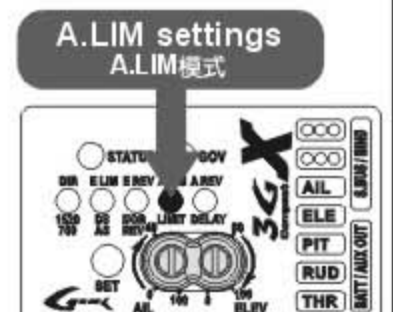
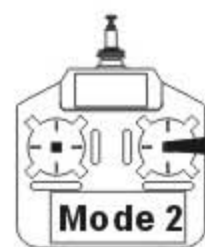

5. A.REV aileron reverse setup mode : A.REV 副翼陀螺儀正反向設定模式 :

Press the SET button to enter A.REV setup mode. The A.REV LED will lit up after A.LIM turns off. Tilt the helicopter right as shown in diagram, and check if swashplate is tilting correctly toward the left. If the swashplate is tilting at the wrong direction, move the transmitter aileron stick until STATUS LED changes color, and re-check the swashplate tilting direction. Press the SET button again, and the control unit will restart with all LED's flashing. This completes the flybarless portion of the setup process.

接著按下"SET"鍵，讓設定模式進入"A.REV副翼陀螺儀正反向"設定模式，此時A.LIM燈熄滅，A.REV燈亮起。此模式設定副翼陀螺儀修正方向，如果將直昇機往右傾，3GX Flybarless應將十字盤向左傾修正，如果反向，可向左或向右推動副翼搖桿，變換"STATUS"不同顏色燈號，更換陀螺儀修正方向。接著按下"SET"鍵完成無平衡翼系統設定，所有LED將閃動，重新開機。

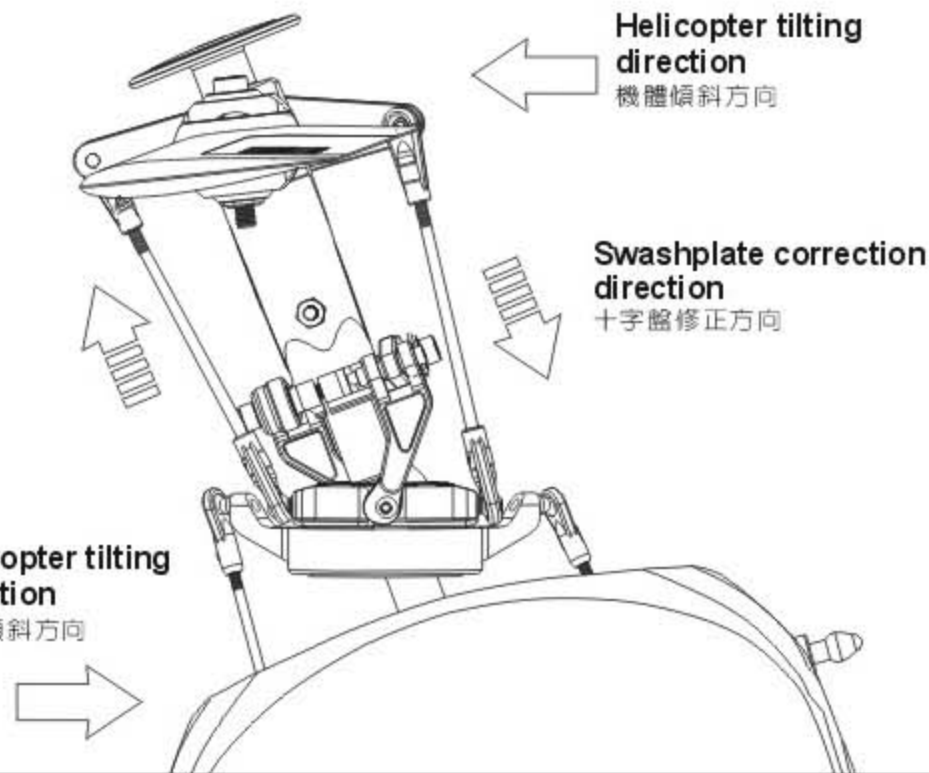

3GX Flybarless system must remain stationary during startup. Do not move the helicopter until the swashplate jumps up and down slightly 3 times, indicating the completion of initialization. (please refer to page 33 step 3)
3GX Flybarless 開機時會進入初始化狀態，此時請勿移動機身，當初始化完成後，十字盤會保持水平上下小幅跳動3次，表示開機完成。(請參考P.33步驟3)

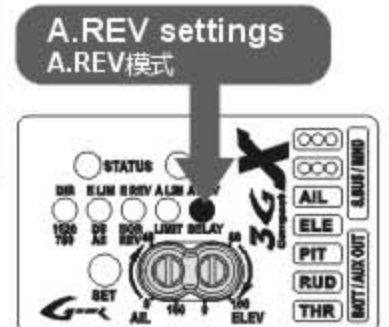

RUDDER GYRO SETUP 尾舵陀螺儀設定

After the system reboots, flybarless setup is completed. Now the rudder gyro needs to setup with similar procedure as Align's GP780 gyro. Push and hold the SET button for 2 seconds to enter the rudder gyro setup mode.

If your transmitter has the following settings, please disable it or set the value to zero.

完成開機後Flybarless部分已設定完成，接著要設定尾舵陀螺儀，所有設定如同GP780。於待機狀態下持按"SET"鍵2秒進入尾舵陀螺儀設定。如果您的遙控器有下列功能時，請設定為關閉(OFF)或數值設定為零。

- ATS
- Pilot authority mixing
- Throttle to rudder mixing
- Rudder to gyro mixing
- Pitch to rudder mixing
- Revolution mixing



3GX Flybarless rudder gyro has the factory setting of 1520 μ s and DS digital servo. Double check your servospec and change the gyro setting as needed to avoid damages to the servo.

3GX Flybarless 尾舵陀螺儀出廠設定值為：1520 μ s寬頻與DS數位伺服器模式，安裝時請確認您的伺服器規格，避免設定值不同而造成伺服器損壞。

1.1520 μ s (standard) or 760 μ s(narrow band) servo frame rate setup.

1520 μ s (標準)或760 μ s (窄頻)伺服器設定

3GX Flybarless system is compatible with both the 760 μ s narrow frame rate servos (such as Futaba S9256, S9251, BLS251), as well as the standard 1520 μ s frame rate servos (most others). Proper frame rate must be selected based on your servo's specifications.

To enter the setup mode : Press and hold the SET button for 2 seconds until STATUS LED flashes. The 1520/760 LED will light up indicating servo frame rate setup mode. Push the transmitter rudder stick left or right to select the frame rate. For example, if rudder is pushed to the left (or right) and STATUS LED turns green, the frame rate is set to 1520 μ s. To set it to 760 μ s, the rudder stick need to be pushed from the center to the opposing end 3 times for the STATUS LED to turn red, indicating frame rate set to 760 μ s.

3GX Flybarless panel : Each setting value is labeled on the 3G flybarless control unit with either green or red lettering, which corresponds to the STATUS LED color. Subsequent setup mode is entered by a single press of the SET button. Setup mode will exit if no activity is detected in 10 seconds.

3GX Flybarless相容兩種波寬控制系統，若您使用的伺服器屬於760 μ s系統（如Futaba S9256、S9251、BLS251），則必須將3GX Flybarless設定於760的模式，其他未標示760 μ s規格的伺服器，一般皆為1520 μ s系統，須設定為1520的模式。

進入功能設定模式：持按面板上的"SET"設定鍵約2秒，此時"STATUS"狀態指示燈會開始閃爍，且"1520/760"的功能設定指示燈會亮起，表示進入標準/窄頻伺服器選項，利用遙控器方向舵搖桿的左右方向來選擇設定值，例如方向舵搖桿往左（或右）時，"STATUS"指示燈為綠色，表示設定值為1520 μ s系統；若要設定為窄頻760 μ s系統時，必須將搖桿由中立點往相反方向連續撥動3次，使"STATUS"指示燈亮紅色，才會進入760 μ s系統。

3GX Flybarless的面板：標籤上已使用綠/紅色的字體提示"STATUS"燈色所代表的設定值。設定完成後按"SET"鍵一次可進入下一個設定，或是10秒內不做任何設定，系統會自動離開設定模式。

Green LED : 1520 μ s standard band
Red LED : 760 μ s narrow band
綠燈 : 1520 μ s寬頻伺服器
紅燈 : 760 μ s窄頻伺服器



Standard/Narrow band mode
寬頻/窄頻模式

Select by moving the rudder stick left and right
左右撥動方向舵選擇

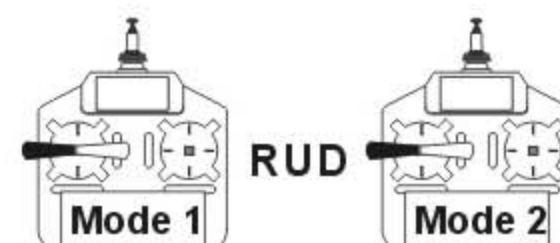

2. DS (digital) / AS (analog) servo selection

DS數位/AS類比伺服器選擇

There is a direct correlation between servos' speed to gyro's performance. Faster servos are able to execute commands from the gyro at faster and higher precision. Due to the high performance gyro sensors used in the 3GX flybarless system, premium high speed digital rudder servos are mandatory for optimal tail performance. Some of the recommended rudder servos include Align DS650, DS620, DS520, DS420, Futaba S9257, S9256, S9254, S9253, or other servos with similar specifications.

Setup method : Press and hold the SET button for 2 seconds to enter the setup mode, then press the SET button to select DS/AS setup mode, as indicated by the lighting of DS/AS LED. Using the transmitter's rudder stick, select either digital servo DS mode (STATUS LED is green), or analog servo AS mode (STATUS LED is red).

伺服器動作速度攸關陀螺儀的性能，伺服器動作愈快，就能立即反應陀螺儀送出的指令，發揮快速精準的效能；由於3GX Flybarless具有相當快速的反應時間與靈敏度，所以建議您搭配高速型數位伺服器，如ALIGN DS650、DS620、DS520、DS420、Futaba S9257、S9256、S9254、S9253或其他相同規格伺服器，以獲得最佳效能。

設定方式：持按"SET"鍵2秒進入功能設定模式，再按"SET"鍵選擇DS/AS選項，(DS/AS指示燈亮起)，利用方向舵搖桿選擇數位DS (STATUS為綠燈)或類比AS (STATUS為紅燈)伺服器。



Using an analog servo in DS mode will cause damages to the servo.

在DS模式下連接"AS類比伺服器"將導致伺服器燒毀。

Select by moving the rudder stick left and right
左右撥動方向舵選擇

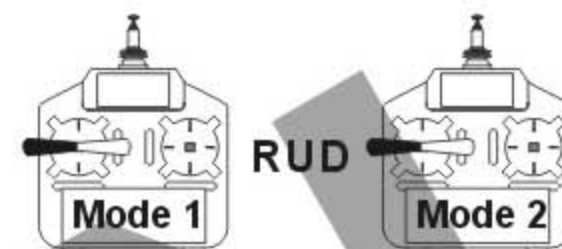

3. Rudder servo direction check and link adjustment

檢查尾舵伺服器正逆轉方向與調整連桿

Move the transmitter rudder stick left/right, and check for the correct direction of the rudder servo. If needed, servo reverse is done from the transmitter's REV (reverse) function.

For tail pitch adjustment, center the rudder servo by either setting the 3GX flybarless to normal rate mode (non-heading lock), or press and hold the SET button for 2 seconds. With the rudder servo centered and servo horn at 90 degrees, adjust the linkage length until tail pitch slider is centered on the tail output shaft as shown in diagram.

左右撥動尾舵搖桿，確認尾舵伺服器移動的方向是否正確，若不正确請更改遙控器上的尾舵伺服器正逆轉方向。

將3GX Flybarless切換成非鎖定模式或持按"SET"鍵2秒，使尾舵伺服器保持在中立點的位置上，調整伺服器舵片，盡可能使尾舵連桿與伺服器擺臂呈90度，接著調整連桿長度使尾Pitch控制組置中。

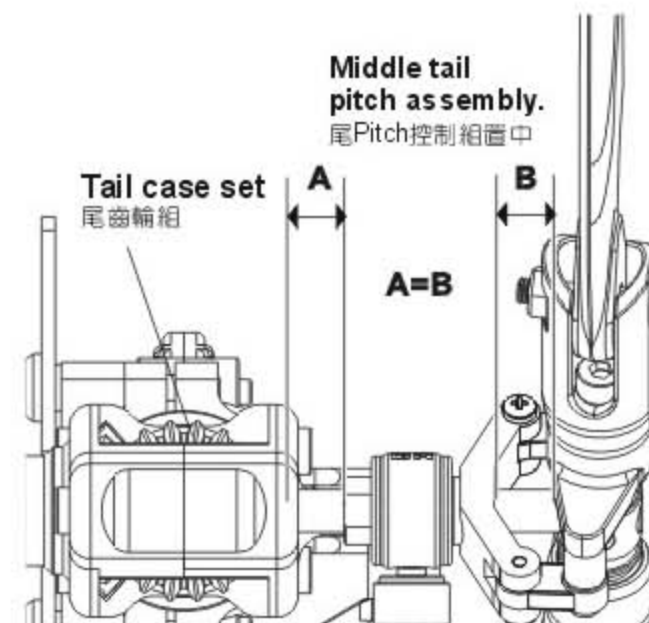
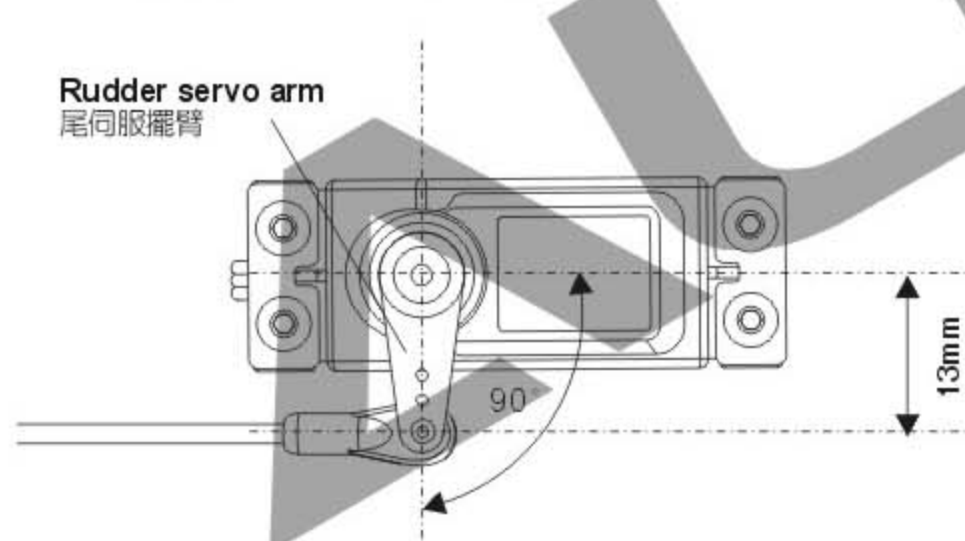

4. Gyro NOR/REV setting

NOR/REV陀螺儀正反向開關設定

Lift up the helicopter by hand, and turn it to the left (yaw). Check if the rudder servo is applying correct compensation to the right. If reversed, set the NOR/REV setting as follow.

Setup method : Press and hold the SET button for 2 seconds to enter the setup mode, then press the SET button to select NOR/REV setup mode, as indicated by the lighting of NOR/REV LED. Using the transmitter's rudder stick, select either NOR (STATUS LED is green), or REV (STATUS LED is red).

提起直昇機，將機頭往左擺動，若尾舵伺服器的擺動方向與遙控器的方向舵搖桿打右舵同方向時，表示陀螺儀的動作方向設定正確，若不正确時請更改正反向設定。
設定方式：持按"SET"鍵2秒進入功能設定模式，選擇NOR/REV選項，以方向舵選擇NOR (STATUS為綠燈)或REV (STATUS為紅燈)。



Select by moving the rudder stick left and right
左右撥動方向舵選擇

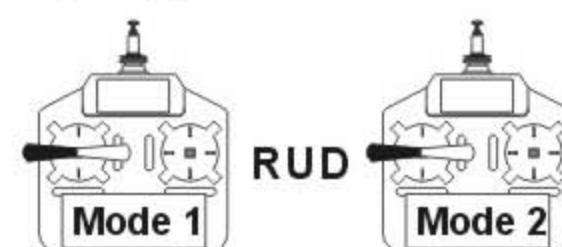

5. LIMIT rudder servo endpoint setting

LIMIT尾舵伺服器行程量調整

Press and hold the SET button for 2 seconds to enter the setup mode, then press the SET button repeatedly to select LIMIT setup mode, as indicated by the lighting of LIMIT LED. Push the transmitter rudder stick left until tail pitch slider reaches the end, then center the rudder stick and wait 2 seconds for the STATUS LED to flash red. Then push the rudder stick right until tail pitch slider reaches the end, then center the rudder stick and wait 2 seconds for the STATUS LED to flash red. This completes the left and right endpoint limit adjustment of servo travel. Insufficient servo travel will degrade helicopter performance, while excessive travel will cause binding and damage rudder servo.

持按"SET"鍵2秒進入功能設定模式，此時尾伺服器會保持在中立點的位置上，選擇LIMIT選項，接著將方向舵搖桿慢慢的往左移動，使尾控制組達到該側的大行程限度後，將搖桿回歸中立點不動，待2秒後"STATUS"指示燈會亮紅燈閃爍，表示左側行程量已記憶；接著將尾舵搖桿向右移動至控制組最大行程限度後，再將搖桿回歸中立點不動，待2秒後"STATUS"指示燈亮紅燈閃爍，即完成左右行程量設定，行程量不足時會影響陀螺儀與直昇機的性能，行程量過大易造成伺服器損壞。

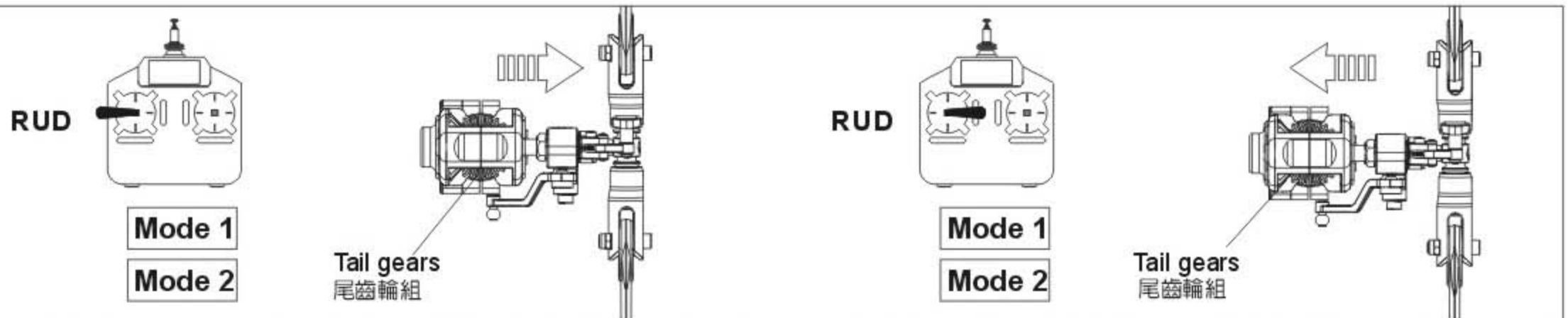

Push the transmitter rudder stick left until tail pitch slider reaches the end, then center the rudder stick and wait 2 seconds for the STATUS LED to flash red. This completes the rudder endpoint limit adjustment for the left side.

將方向舵慢慢往左撥動，使控制組達到左舵最大行程限度後，將搖桿回歸中立點不動，待2秒後"STATUS"紅燈閃爍表示左舵行程記憶量完成。

Push the rudder stick right until tail pitch slider reaches the end, then center the rudder stick and wait 2 seconds for the STATUS LED to flash red. This completes the rudder endpoint limit adjustment for the right side.

將方向舵慢慢往右撥動，使控制組達到右舵最大行程限度後，將搖桿回歸中立點不動，待2秒後"STATUS"指示燈表示右舵行程記憶量完成。

Flashing red LED indicates settings have been registered
紅燈閃爍時表示記憶完成



Endpoint limit settings
行程量設定



Rudder travel limit setting lower than 50% will not be registered. Mechanical fix (moving link ball closer to center of servo horn) is needed for excessive servo travel when LIMIT function is below 50%.

尾舵行程量設定不可低於50%，否則3GX Flybarless將不予記憶，若發生行程量設定後，尾控制組仍會超過最大行程，請將尾伺服器臂的球頭向內移動，避免行程不足影響陀螺儀性能。

6. Helicopter size and DELAY settings

直昇機模式與DELAY控制延遲量調整

This setting includes two functions :

- (1) For small helicopters such as T-Rex 250/450, set this setting to small helicopter (STATUS LED red). For larger helicopters such as T-Rex 500/550/600/700 set this setting to large helicopter (STATUS LED green).

此設定結合兩項功能：

- (1) 3GX Flybarless支援小型/迷你型室內電直，請依您直昇機的類型選擇適合的模式，如：T-REX250/450請選擇小型/迷你型模式（設定時"STATUS"指示燈為紅色）；T-REX500/550/600/700請選中大型直昇機模式（設定時"STATUS"指示燈為綠色）。

Green LED: suitable for larger helicopters such as T-REX500/550/600/700
Red LED: suitable for smaller helicopter such as T-REX 250/450

綠燈：適用T-REX500/550/600/700大型直昇機
紅燈：適用T-REX250/450小型直昇機

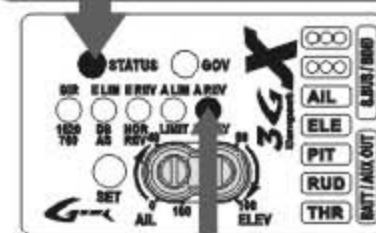

Helicopter size selection and servo delay settings
大小直昇機模式與延遲量設定

Select by moving the rudder stick left and right
左右撥動方向舵選擇

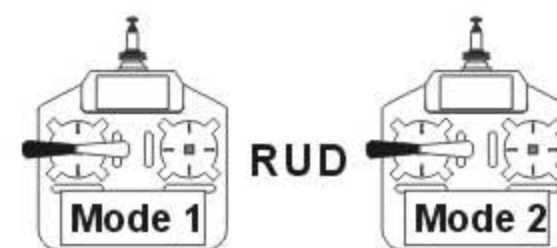

- (2) The DELAY function is utilized when slower rudder servo causes tail hunting (wagging). This can be observed after a hovering pirouette comes to a stop. If tail hunting occurs, gradually increase DELAY value to eliminate it. For best performance, DELAY value should be kept as low as possible without tail hunting.

Setup method : Press and hold the SET button for 2 seconds to enter the setup mode, then press the SET button to select DELAY setup mode, as indicated by the lighting of DELAY LED. The choice of small or large helicopter is done by moving the transmitter rudder stick left or right while observing the color of the STATUS LED. For small helicopters STATUS LED will be red, and large helicopter will be green. The amount of servo delay is set by how far you push the rudder stick, followed by pushing the SET button.

- (2) 使用速度較慢的尾舵伺服器較容易產生追蹤現象，當直昇機停懸時，打方向舵使直昇機快速自轉，當方向舵回到中立點使直昇機停止自轉時，此時若發生追蹤現象，請增加控制延遲的設定量，一般而言在不產生追蹤現象的原則下控制延遲的設定量愈小愈好，否則尾舵的動作會變得遲緩。

設定方式：持按"SET"鍵2秒進入功能設定模式，選擇至DELAY選項，以方向舵搖桿選擇小型/迷你型電直，

如：T-REX 250/450 (STATUS為紅燈)，或中大型直昇機如T-REX500/550/600/700 (STATUS為綠燈)，若要同時設定DELAY控制量時，則利用方向舵搖桿的位置來設定，搖桿由中立點推至"DELAY"燈開始閃爍時為0%，推至最大行程時控制量為100%，將搖桿推至所需的延遲量時保持不動，並按下"SET"鍵確認，即可同時設定直昇機模式與延遲量。

Green LED for T-REX550
T-REX550設定為綠燈

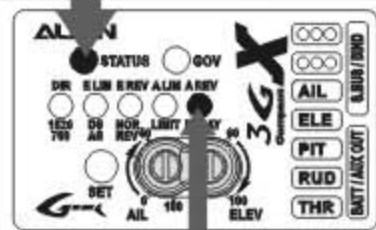

0% when DELAY LED begins flashing
DELAY燈開始閃爍時為0%

Green LED for T-REX550
T-REX550設定為綠燈

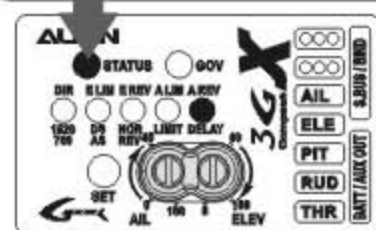

Gradually move the transmitter rudder stick until DELAY LED begins to flash, the delay value is 0% at this point.
輕推方向舵搖桿至"DELAY"燈開始閃爍時，延遲量為0%

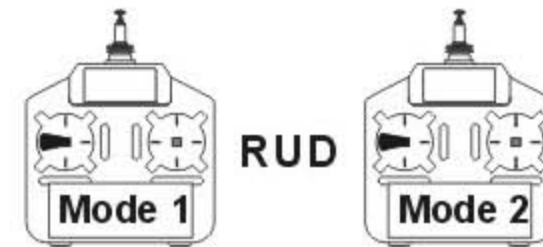

Continue to move the rudder stick until desired delay value is needed, then press the SET button to register the setting. Maximum is 100% delay, with rudder stick pushed to the end.
方向舵推至最大行程時，延遲量為100%，將搖桿推至所需的延遲量，按下"SET"鍵確認

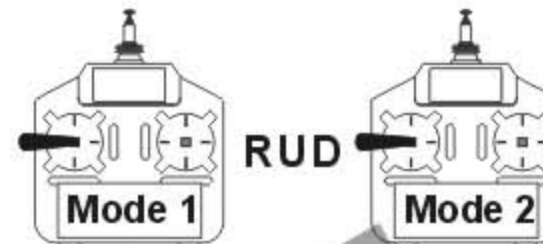

7. Sensitivity Adjustment 感度調整

For radio with built in gyro gain settings, gain can be adjusted directly. For example, 50%-100% setting on the radio translates to 0% - 100% gain in the heading lock mode; 50%-0% setting on the radio translates to 0%-100% gain in the normal (non-heading) lock mode.

Actual gain value differs amongst servos and helicopters. The goal is to find the maximum gain without tail hunting. This can only be done through actual flight tests.

The recommended starting point for transmitter's gyro gain setting should be 70~80% for hovering, 60~70% for idle-up. Value should be tuned under actual flight conditions by increasing to the maximum gain without tail hunting.

一般具有陀螺儀感度設定功能的遙控器，可直接進入GYRO功能選項進行感度值的設定，設定值50%則陀螺儀的感度為0，設定值50%~100%，則陀螺儀感度值為鎖定狀態的0~100%；設定值50%-0%，則陀螺儀感度值為非鎖定狀態的0~100%。

感度值的大小會隨著伺服器與直昇機的不同而有所差異，一般而言，在不產生追蹤現象（直昇機尾部出現左右搖擺的情況）的前提下感度值愈高愈好，所以只能透過實際飛行的狀況來進行調整。

進入遙控器感度設定的選項，一開始停懸時建議先設定在70~80%左右，Idle up飛行時設定在60~70%左右，之後再依實際飛行的狀態再行修正，如果沒有追蹤現象發生時可再調整高感度，若發生追蹤現象時，則調低感度。



For radios (IE Futaba) using 0-100% as heading lock gain scales, the recommended gain setting is 30% to 35%.
For radio that uses the 50 -100% scale (such as JR and Hitec), the recommended gain setting is 70% to 75%.
鎖定感度值為0~100%的遙控器，如Futaba，建議設定在30~35%左右；鎖定感度值為50~100%的遙控器，如JR、HITEC，建議感度值設定在70~75%左右。

Specifications 產品規格

- | | | | |
|---|--|--|---|
| <p>1. Operating voltage range :
DC 3.5V~8.4V</p> <p>2. Operating current consumption :
<80mA @ 4.8V</p> <p>3. Rotational detection rate : ± 300°/sec</p> <p>4. Rudder yaw detection rate : ± 600°/sec</p> <p>5. Sensor resolution : 12bit</p> <p>6. Operating temperature : -10°C~60°C</p> | <p>7. Operating humidity : 0%~95%</p> <p>8. Dimension/Weight :
36.5x25.5x15.6mm/ 11g</p> <p>● RoHS certification stamp</p> | <p>1. 適用電壓：DC 3.5V~8.4V</p> <p>2. 消耗電流：<80mA @ 4.8V</p> <p>3. 偵測側滾及前滾角速度：± 300°/sec</p> <p>4. 偵測尾舵角速度：± 600°/sec</p> <p>5. 感應器解析度：12bit(12位元)</p> <p>6. 操作溫度：-20°C~65°C</p> | <p>7. 操作濕度：0%~95%</p> <p>8. 尺寸/重量：
36.5x25.2x15.6mm/11g</p> <p>● 符合RoHS限用規章</p> |
|---|--|--|---|

15. RCM-BL600MX 1220KV POWER COLLOCATION REFERENCE 原裝動力數據參考表 **ALIGN**

BATTERY 電池：ALIGN Li-Poly 22.2V 5200mAh

Motor Pinion Gear 馬達齒輪	Main Rotor Blade 主旋翼規格	Pitch 螺距	Current(A) approx. 電流(A)大約值	Throttle Curve 油門曲線	RPM approx. 主旋翼轉速大約值	
16T	520 Carbon Fiber Blades 520碳纖主旋翼	Hover 停懸	+5° 16	0/50/65/85/100%	1900	
		Idle 1	0°	22	85% Middle 中	2580
			0°	26	100/100/100/100/100%	2760
			± 12°	50		2620
16T	550 Carbon Fiber Blades 550碳纖主旋翼	Hover 停懸	+5° 17	0/50/65/85/100%	1880	
		Idle 1	0°	23	85% Middle 中	2540
			0°	28	100/100/100/100/100%	2710
			± 12°	52		2570

NOTE: 1. Please do not use 550mm CF blades with 17T motor pinion gear.
2. Please use a pitch gauge to adjust the pitch value. Incorrect excess pitch setting will result poor helicopter performance and reduce ESC's life and battery's life.

註：1. 550mm碳纖主旋翼勿搭配17T馬達齒飛行
2. 請務必使用螺距規來量測調整螺距，不正確的過大螺距設定不但無法發揮直昇機的特性，反會影響到無刷調速器與電池的壽命。

PRODUCT FEATURES 產品特色

1. 5-6V step-less adjustable BEC output allowing custom voltage setting to match servo specification.
 2. BEC output utilizing switching power system, suitable for 7.4-22.2V (2S-6S) Li battery, with continuous current rating of 3A, and burst rating of 5A.
 3. Three programmable throttle speed settings to support quick throttle response.
 4. Include soft start and governor mode.
 5. Small and compact PCB design for lightweight and simple installation.
 6. Large heat sink for optimum thermal performance.
 7. Highly compatible to work with 98% of all brushless motors currently on the market.
 8. Ultra-smooth motor start designed to run with all kinds of brushless motors.
 9. The power inlet utilizes a Japanese made "Low ESR" capacitor in order to provide stable power source.
 10. The throttle has more than 200 step resolution that provides great throttle response and control.
1. 5~6伏特無段可調式BEC輸出，可依伺服器規格與所需的特性自行設定電壓。
 2. BEC輸入端採用交換式電源設計，適用7.4~22.2V (2S~6S) 鋰電，持續耐電流3A，瞬間5A。
 3. 三段可程式油門反應速度，使動力的反應隨傳隨到。
 4. 具緩啟動及Governor Mode定速功能。
 5. 體積小，窄型設計，安裝於機身容易。
 6. 有散熱片設計，可延長電變壽命。
 7. 超高相容性，可對應市面上 98% 無碳刷馬達。
 8. 絕佳起步設計，無論國產、進口、內轉、外轉無刷馬達皆起步順暢。
 9. 電池電源端採用日製 Low ESR 低阻抗電解電容，大幅提高電源之穩定性。
 10. 油門達 200 段以上解析度，無格數之油門感覺。

WIRING ILLUSTRATION 接線示意圖**SPECIFICATION 規格**

Model 型號	Continuous Current 持續	Peak Current 瞬間	BEC Output BEC輸出	Dimension 尺寸	Weight 重量
RCE-BL70G	70A	110A 5sec	Output voltage: 5-6V step-less adjustment Continuous current 3A; Burst current 5A 輸出電壓: 5~6V無段可調式 承受電流: 持續3A、瞬間5A	65x31x18mm	72g

1. Good temperature situation for working at the maximum current
2. Supporting motor types: 2~10 pole in/outrunner brushless motors.
3. Supporting maximum RPM: 2 pole → 190,000 rpm ; 6 pole → 63,000 rpm.
4. Input voltage: 5.5V ~ 25.2V (2~6S Li-Po)

NOTE: 1. When setting to the Quick throttle response speed, the accelerative peak current will increase.
2. To minimize possible radio interference induced by switching power system, BEC should be installed at least 5cm away from the receiver. The use of PCM or 2.4G receiver is recommended.

1. 持續最大電流需在機體散熱良好情況下。
2. 支援馬達型式: 二極至十數極之內外轉子無碳刷馬達。
3. 支援最高轉速: 二極→190,000rpm; 六極→63,000rpm。
4. 輸入電壓: 5.5V~25.2V (2~6S Li-Po)

注意: 1. 設定為高油門反應速度時，加速瞬間電流會有增大情形。
2. 內建Switching BEC，安裝時請與接收器保持至少5cm以上的距離以避免干擾接收器 (建議使用較穩定的PCM或2.4G系統接收器)。

FUNCTIONS 產品功能

1. Brake Option - 3 settings that include Brake disabled/Soft brake/Hard brake.
2. Electronic Timing Option - 3 settings that include Low timing/Mid timing/High timing. Generally, 2 pole motors are recommended to use low timing, while 6 or more poles should use Mid timing. High timing gives more power at the expense of efficiency. Always check the current draw after changing the timing in order to prevent overloading of battery.
3. Battery Protection Option - 2 settings that include Li-ion, Li-poly High/Middle cutoff voltage protection. The default setting is high cutoff voltage protection. CPU will automatically determine cell number of input Lithium battery (2S~6S). This option will prevent over-discharge of the battery. The following reference is the guideline for setting the Battery Protection option.
 - 3-1 Li-ion/Li-poly High cutoff voltage protection - When the voltage of single cell drops to 3.2V, the first step of battery protection mode will be engaged by the ESC resulting in reduced power. The pilot should reduce the throttle and prepare landing. If the voltage of single cell drops to 3.0V, the second step of battery protection mode will be engaged resulting in power cutoff. (*Note 1) For 11.1V/3cells Lithium battery, the full charged voltage will be approximately 12.6V. According to this input voltage, CPU will determine that this is a 3cell battery.
First step protection: 3.2V x 3cell=9.6V
Second step protection: 3.0V x 3cell= 9.0V
When the voltage drops to 9.6V, the power will be reduced. When the voltage drops to 9.0V, the power will be cut off.
 - 3-2 Li-ion/Li-poly Middle cutoff voltage protection - This option is same as instruction 3-1, but when the voltage of single

cell drops to 3.0V, the first step of battery protection will be engaged. When the voltage of single cell drops to 2.8V, the second step of battery protection will be engaged. (*Note 1)

Note 1: Second step of battery protection only works when Aircraft mode is setting to the option 4-1.

NOTE: THIS OPTION IS ONLY SUITABLE FOR A FULLY CHARGED BATTERY PACK IN GOOD WORKING CONDITION.

4. Aircraft Option: 3 settings that include Normal Airplane / Helicopter 1 / Helicopter 2.

Normal Airplane Mode is used for general airplanes and gliders. When flying Helicopters, you can choose Helicopter 1 Mode, or Helicopter 2 Mode. Helicopter 1 Mode provides Soft Start feature. Helicopter 2 Mode provides Soft Start and Governor Mode.

5. Throttle response speed: 3 settings that include standard/ Medium/ Quick throttle response speed.

The default setting is "quick speed". Use this option to adjust the setting according to flight character. For example, setting at Medium or Quick speed for 3D and powerful flight to make the power response more quickly, but note the accelerative peak current and power expense will increase.

6. BEC output voltage setting: 5-6V step-less adjustment.

This option allows custom voltage setting. Default setting is 5.5V; please adjust the voltage according to the specification of the servo (speed and resistance). Prior to entering the setup mode, a voltmeter needs to be connected to the power inlet of the receiver (as illustration) to monitor the selected voltage. The voltage is set by varying the throttle stick position from low (5V) to high (6V).

The voltmeter needs to be connected to any un-use inlets "+" and "-" to measure the selected voltage.

將電壓表連接到任一未使用通道的 "+" 端及 "-" 端，以量測所選擇的電壓。

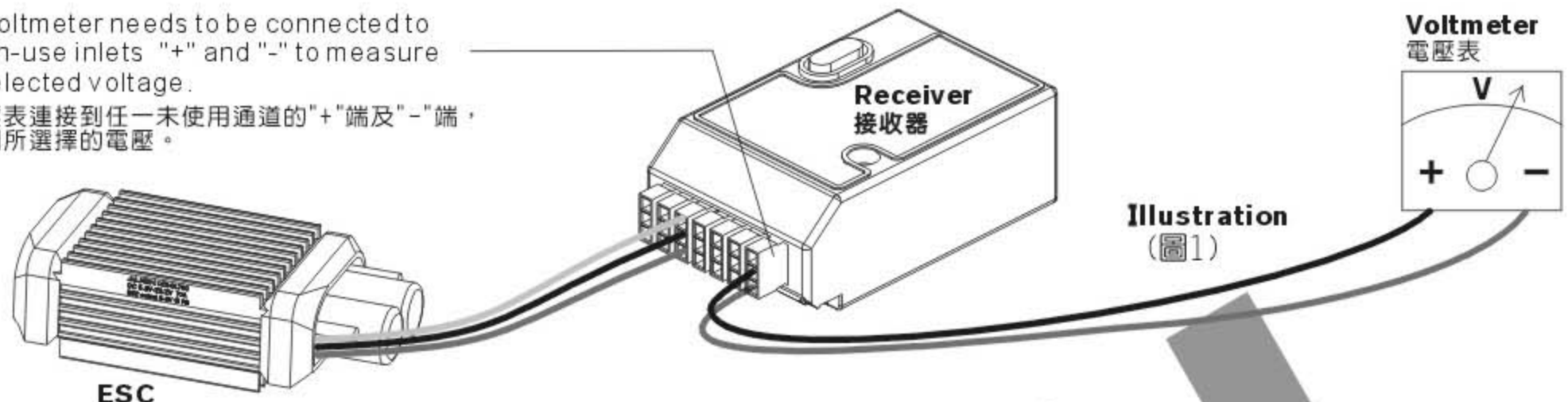

NOTE: Certain servos are designed to work with high voltage, while other servos are designed for lower voltage.

To avoid damage to servos, please follow the servo's factory specification to determine the proper voltage setting.

注意: 部份伺服器不適合較高的電壓下操作，請依原廠適用電壓規格設定，避免造成伺服器燒毀。

7. Thermal Protection: When the ESC temperature reaches 80°C for any reason, it will engage the battery protection circuit, reducing power to the ESC. We recommend mounting the ESC in a location with adequate air flow and ventilation.

8. Safe Power On Alarm: When the operator turns on the ESC, it will automatically detect the transmitter signal. The ESC will emit a confirmation tone and enter normal operation mode if the throttle is set to the lowest position. If the throttle position is at full throttle, it will begin to enter Setup Mode. If the throttle is in any other position, the ESC will emit an alarm and not enter into user mode for safety precautions.

9. Aircraft Locator: If the aircraft should land or crash in an unexpected location and become lost, the pilot can enable the Aircraft Locator Option. The Aircraft Locator Option is engaged by turning off the transmitter. When the ESC does not receive a signal from the transmitter for 30 seconds, it will start to send an alarm to the motor. The sound of the alarm will aid the pilot to locate the aircraft. This option will not work with a PCM receiver that has SAVE function enabled, or with low noise resistant PPM receivers.

1. 煞車設定: 三段選擇分為無煞車 / 軟性煞車 / 急煞車

2. 進角設定: 三段選擇分為低進角 / 中進角 / 高進角

設定時機分為二極以及六極以上無碳刷馬達，二極無碳刷馬達一般適用低進角，若希望馬達轉速提高，可將進角設定為中進角。六極以上無碳刷馬達一般適用中進角，若希望馬達轉速提高，可將進角設定為高進角。然而進角之調整需要注意電流之變化，避免電池過載，影響電池及馬達壽命。

3. 電池保護電壓設定: 二段選擇分為 Li-Ion、Li-Po 高截止電壓保護/中截止電壓保護

出廠設定為高截止電壓保護；此功能會自動判定所輸入鋰電池的cell數(2~6S)，並提供使用者對該電池之放電保護，以避免因放電電壓過低而造成電池損壞，以下為設定值之解說：

3-1 Li-Ion/Li-Po高截止電壓保護：當鋰電單cell壓降達3.2V時，電變會啟動第一階段保護，使動力間歇性中斷，此時使用者應將油門收小，準備降落；而當單cell電壓持續壓降達到3.0V時則會啟動第二階段保護，完全限制動力輸出(註1: 僅在4-1選項"一般飛機模式"下才會啟動第二階段保護)。

例: 以一個使用11.1V 3cell鋰電池之系統而言11.1V鋰電池充飽電壓約12.6V，此輸入電壓CPU會自動判定為3cell鋰電。

第一階段保護: 3.2Vx3cell=9.6V 第二階段保護: 3.0Vx3cell=9.0V 當電壓降至9.6V時，動力會間歇性中斷，當壓降達到9.0V時則完全限制動力輸出。

3-2 Li-Ion/Li-Po中截止電壓保護: 同3-1功能說明，但單cell壓降達到3.0V時，會啟動第一階段保護，單cell壓降達到2.8V時啟動第二階段保護(註1)。

注意: 以上功能僅適用於充飽電，且功能正常的鋰電池。

4. 飛機模式設定: 三段式選擇分為: 一般飛機模式/直昇機模式1/直昇機模式2

使用於一般飛機或滑翔機時，請設定於一般飛機模式，使用於直昇機時可選擇直昇機模式1: 具有緩啟動功能，或直昇機模式2: 具有緩啟動及Governor Mode定速功能。

5. 油門反應速度設定: 三段選擇分為標準/中速/快速

出廠設定值為"快速"油門反應速度，此功能提供使用者依所需的飛行特性來作適當的調整，例如3D飛機與劇烈的3D直昇機飛行時可設定為中速或快速，使動力反應更加快速、靈敏，但須注意提高油門反應速度時，加速瞬間電流與耗電量會有增大的情形。

6. BEC輸出電壓設定: 5~6V無段調整

本功能提供使用者自行設定BEC輸出電壓，初始電壓為5.5V，使用者可依伺服器的規格與所需的特性(速度與扭力)自行更改設定；進入此項設定前，請先將電壓表連接到接收器的電源端(如圖1)，用以監看所選擇的電壓，設定時以油門搖桿的位置來決定輸出電壓，油門搖桿最低為5伏特，最高為6伏特，之間的電壓值可移動搖桿的位置任意設定。

7. 溫度保護: 當電變因不良之空氣對流或是過載輸出導致溫度上升達 80°C時，電變會啟動溫度保護，而使動力間歇性中斷，建議將電變裝置在機艙內空氣對流之位置，並實際使用電流量表測輸出電流，以達到電變之最佳效率。

8. 開機防暴衝提醒功能: 當使用者開啟電變電源時，系統會自動偵測發射機之設定，如果發射機油門未置於最低點，或未置於最高點準備進入設定模式，馬達將不會轉動，同時會有警示聲響提醒。

9. 尋機功能: 當飛機降若再長草區無法以目視定位時，使用者可將發射機關閉，當電變無法接收來自接收機信號時，電變會於三十秒後使馬達發出警示聲響，以利定位。此功能不適用於設定了 SAVE 功能之 PCM 接收機，或抗雜訊低之 PPM 接收機。

SETUP MODE 設定模式

1. Setup mode: Make sure to connect the ESC to the throttle channel of the receiver. Please refer to the user manual of your radio system. The second step is to connect the 3 power-out signal pins to the brushless motor. Before you turn on the transmitter, please adjust the throttle stick to the maximum full throttle position. Proceed to connect the battery to the ESC. You will hear confirmation sounds as soon as you enter the SETUP MODE. Please refer the attached flow chart for details.
2. Throttle stick positions in Setup mode: Setup mode includes six settings: Brake, Electronic Timing, Battery Protection, Aircraft, Throttle Response Speed and BEC output voltage. Every setting has three options. Simply place the throttle stick in the highest, middle, and lowest positions for each setting. For example, first brake setting (Hard): move the stick to the highest position. Then timing setting (mid): move the throttle stick in the middle position.

1. 進入設定模式:將電變與接收器之油門 Channel 連接,不同之遙控系統請參閱遙控系統之使用手冊,馬達之三條線亦與電變連接,將發射器之油門搖桿推到最高點,使之於全油門狀態,先開啓發射器電源,再將電源連接至電變,進入設定模式後,馬達將有設定模式之提示聲響。請參考第二頁程式化設定模式說明。
2. 設定模式中之動作:設定模式共含有六項設定,分別為煞車、馬達進角、電池保護、飛機模式、油門反應速度級、BEC 輸出電壓等設定,詳細內容請參考產品功能之解說。每一項設定中各含三段設定,各項設定以油門搖桿之上、中、下位置來決定其設定值。
例如:煞車設定時,油門搖桿撥至最高,則設定為急煞車,進入第二項進角設定時,油門搖桿撥至中間,則設定為中進角。

Mode 設定模式	Throttle position 油門搖桿	Low 低	Middle 中	High 高
Brake 煞車設定		● Brake disabled(1-1) 無煞車(1-1)	Soft brake(1-2) 軟性煞車(1-2)	Hard brake(1-3) 急煞車(1-3)
Electronic Timing 進角設定		Low-timing(2-1) 低進角(2-1)	● Mid-timing(2-2) 中進角(2-2)	High-timing(2-3) 高進角(2-3)
Battery Protection 電池保護電壓設定		● High cutoff voltage protection(3-1) 高截止電壓保護(3-1)	Middle cutoff voltage protection(3-2) 中截止電壓保護(3-2)	—
Aircraft 飛機模式設定		Normal Airplane/Glider(4-1) 一般飛機 / 滑翔機(4-1)	● Helicopter 1 (Soft Start)(4-2) 直升機模式1(緩啟動功能)(4-2)	Helicopter 2 (Soft Start+ Governor Mode)(4-3) 直升機模式2(緩啟動+Governor Mode定速功能)(4-3)
Throttle response speed 油門反應速度設定		Standard(5-1) 標準(5-1)	Medium speed(5-2) 中速(5-2)	● Quick speed(5-3) 快速(5-3)
BEC output voltage BEC輸出電壓設定		5.0V	● 5.5V	6.0V

Note: "●" default setting
註: "●" 表示出廠設定值

Chart A
表A

ESC START-UP INSTRUCTION 開機使用模式



CURRENT SETTINGS INDICATOR BEEPS EXPLANATION 開機模式設定響音提示說明



INSTRUCTIONS ON AIRCRAFT MODE SETTINGS 飛機模式設定使用說明

Normal Airplane/Glider Mode (Option 4-1):
This option is applied to general airplanes and gliders.

Helicopter 1 Mode (Option 4-2):
This option provides a soft start feature and is applied to Helicopters for Normal, Idle Up 1, or Idle Up 2 modes.
Please note that the sensitivity of the gyro should be set lower when flying in Idle Up 1 or Idle Up 2 modes if tail hunting (wag) occurs due to higher rotor speed.

Helicopter 2 Mode (Option 4-3):
This option supports soft start as well as Governor Mode features and is applied to Helicopters for Idle Up 1 and Idle Up 2 modes(not suitable for Normal Flight Mode). When Governor Mode is in use, the throttle should be set between 75% and 85%. Again if tail wag occurs, lower the sensitivity of the gyro to eliminate the hunting effect. The Governor Mode may not work properly in cases of insufficient rotor speed (due to improper gear ratio), poor battery discharge capability, and improper setting of gyro sensitivity and the blade pitch, etc. Please make sure all the proper adjustments have been done when using Governor Mode.

- 一般飛機模式(選項4-1):適用於一般飛機及滑翔機。
- 直昇機模式1(選項4-2):具有緩啟動功能,適用於Normal、Idle1、Idle2等飛行模式,當切換至Idle1或Idle2模式,如有較高轉速造成陀螺儀有輕微的追蹤現象,此時應將陀螺儀的感度設定分別降低。
- 直昇機模式2(選項4-3):具有緩啟動及Governor Mode定速功能,適用於Idle1、Idle2特技飛行模式(不適合Normal飛行模式下選用),選擇定速功能時,油門應定速在75%-85%之間,如果飛行時發現有輕微的追蹤現象時,應降低陀螺儀的感度;由於轉速不足(齒比搭配不當),電池效能不佳,陀螺儀感度設定不當,Pitch設定錯誤,皆會導致無法發揮定速的功能,甚至產生尾部偏擺的情形,所以選擇此模式時應針對相關條件進行確認。

SETUP MODE 程式化設定模式 Minimum 4 channel radio is required 四動以上標準發射器均可執行設定

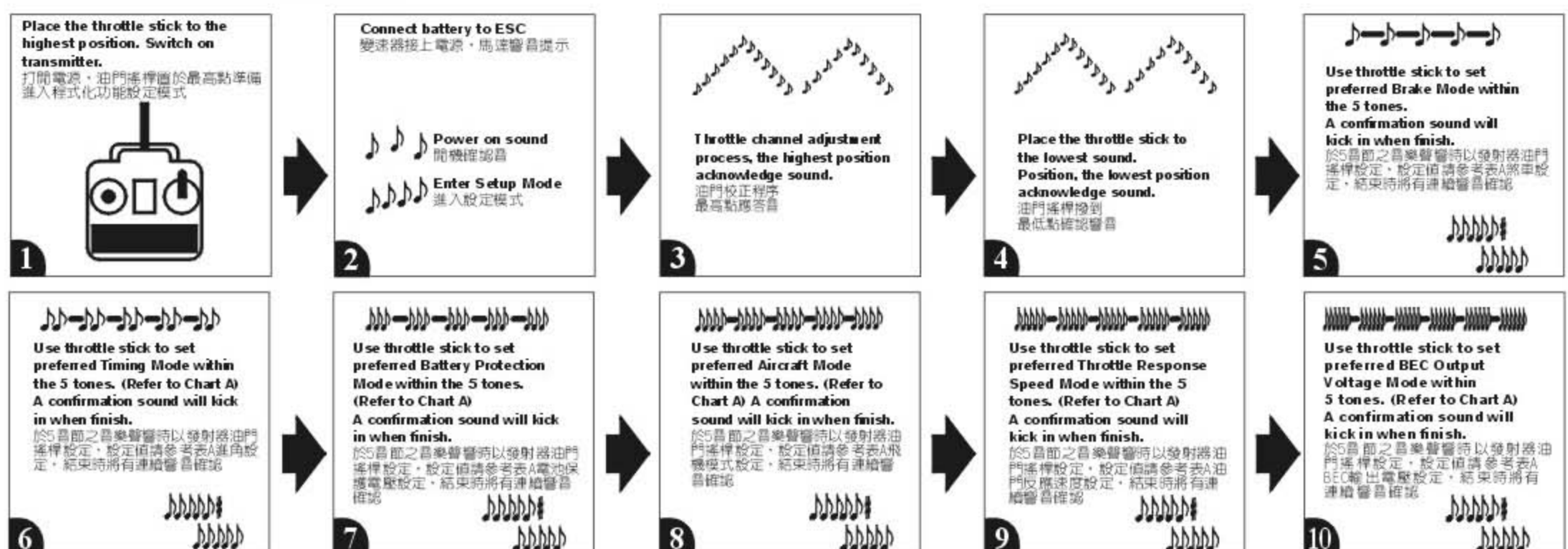

Step1 步驟1

Turn on Transmitter, and then receiver power.
先開啓遙控器電源，再開啓接收器電源。

Step2 步驟2

3GX Flybarless system will go through initialization process, as indicated by flashing of all LED's. Do not move the helicopter or transmitter sticks until initialization process completes.
此時3GX Flybarless控制器指示燈STATUS及DIR~A.REV會閃動，請勿移動直昇機與撥動搖桿，以利陀螺儀感應器進入初始化程序。

Step3 步驟3

The completion of initialization process is indicated by the rapid up and down motion of swashplate 3 times while remaining level. Should the swashplate jumps up and down at a tilted position, the flybarless system initial setup need to be performed again. (Refer to page 23: Flybarless system initial setup)

The pitch of helicopter will remain locked until successful initialization. If the initialization process is unable to complete, with STATUS LED blinking red, Re-check all connections, and perform another reboot with helicopter remain stationary.

Following successful initialization process, green STATUS LED indicates rudder is in heading lock mode, while red LED indicates normal non-heading mode. (Refer to P.29 Gain Adjustment)

如左圖示，初始化完成後，十字盤會保持水平上下小幅跳動三次，表示完成開機程序；如十字盤為傾斜跳動三次，則表示設定錯誤，須進入無平衡翼系統重新設定。（參考P.23 無平衡翼系統設定）

完成開機前直昇機螺距被固定無法動作，如果一直無法完成開機程序STATUS紅燈閃爍，請檢查開機時直昇機是否靜止或訊號線未接妥，確認後重新開機。正常開機後，STATUS亮綠燈表示尾舵為鎖定模式，亮紅燈為非鎖定模式。（請參照P.29感度調整）

Green = rudder in heading lock mode
Red = rudder in normal mode
綠燈為尾舵鎖定模式
紅燈為尾舵非鎖定模式

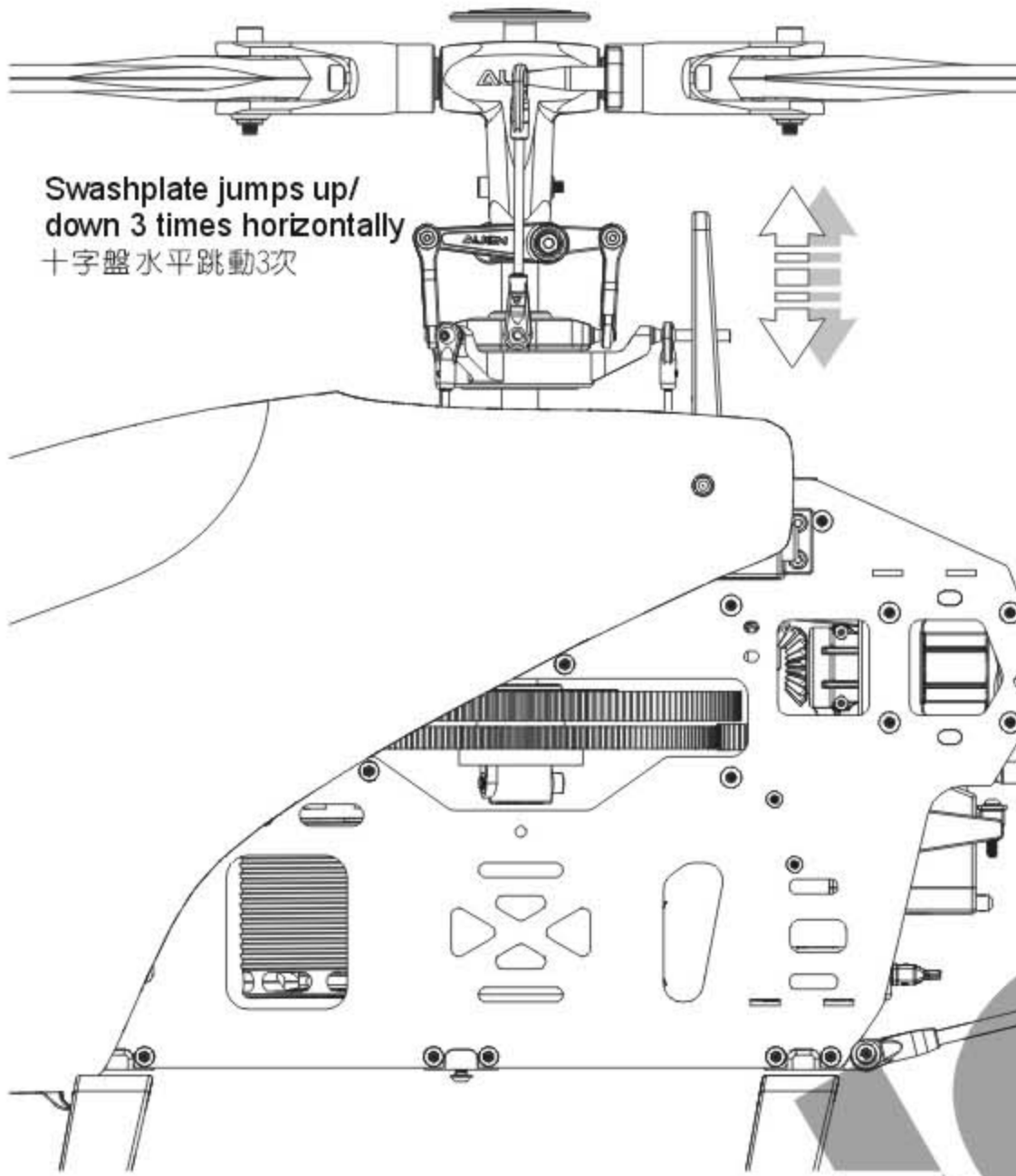
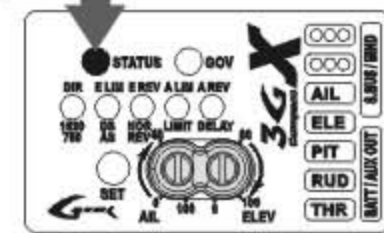

Swashplate jumps up/down 3 times horizontally
十字盤水平跳動3次



Swashplate jumps up and down 3 times horizontally represents successful initialization.
十字盤水平跳動三次代表正常開機



Swashplate jumps up and down 3 times tilted represents setup error.
十字盤傾斜跳動三次代表設定錯誤

Step4 步驟4

Tilt the helicopter forward and swashplate should tilt back to compensate. If reversed, perform the flybarless initial setup again and adjust the elevator reverse setting (Refer to P.25: E:REV setup)
將直昇機往前傾，陀螺儀應將十字盤向後修正，如果反向，重新進入Flybarless設定模式設定升降舵陀螺儀修正方向。（請參考P.25:E.REV升降舵陀螺儀正反向設定模式）

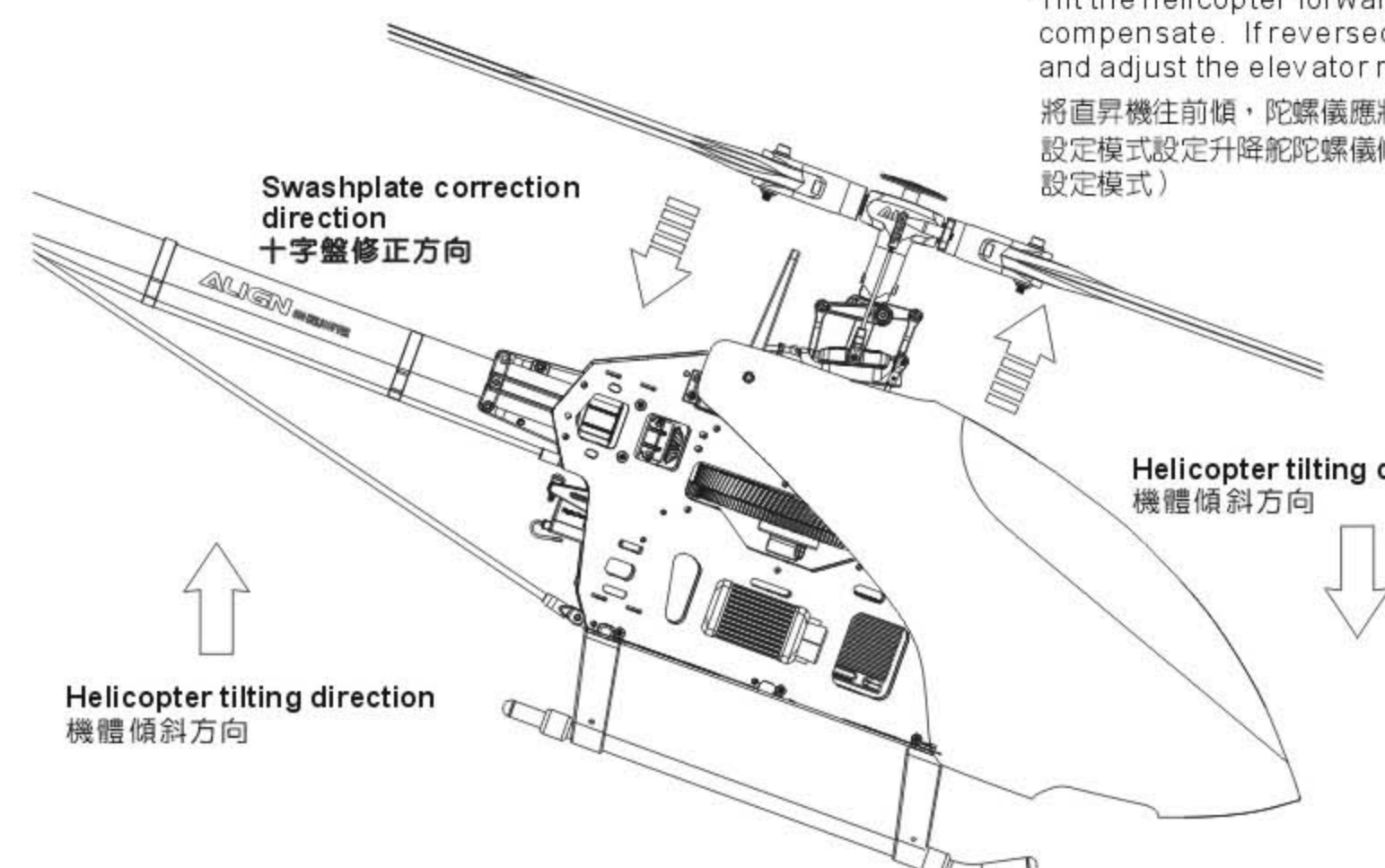

Swashplate correction direction
十字盤修正方向

Helicopter tilting direction
機體傾斜方向

Helicopter tilting direction
機體傾斜方向

Helicopter tilting direction
機體傾斜方向

Swashplate correction direction
十字盤修正方向

Helicopter tilting direction
機體傾斜方向

Step5 步驟5
Tilt the helicopter to the right and swashplate should tilt left to compensate. If reversed, perform the flybarless initial setup again and adjust the aileron reverse setting (Refer to P.26: A:REV setup) 將直昇機往右傾，陀螺儀應將十字盤向左修正，如果反向，重新進入Flybarless設定模式設定副翼陀螺儀修正方向。(如左圖所示：參考P.26: A:REV副翼陀螺儀正反向設定模式)

Step6 步驟6
With throttle stick all the way up (and down), and cyclic stick all the way left/right and up/down, check for any binding on the swashplate. If binding occurs, perform the flybarless initial setup again and adjust the endpoint limits. 將油門搖桿推到最高及最低，並將搖桿左右及前後推到底，十字盤動作是否流暢，如果不是必須重新進入Flybarless設定模式裏設定行程。

Step7 步驟7
Check the center of gravity (CG) and adjust component placement until CG point is right on the main shaft of the helicopter. 檢視直升機重心是否適當請先調整直昇機重心位置至主軸中心線下方位置。

Step8 步驟8
With all above steps checked, restart the system and begin flight test. 確定所有功能正常，重新開機，完成開機程序後進入飛行測試。

HELICOPTER CG CHECK PROCEDURE 直昇機機體重心檢視方式

After the battery is assembled, hold the helicopter as shown. Once the helicopter stops rotating, the helicopter's CG can be seen at where the head is pointing relative to the main shaft.

將電池固定於電池座後，將直昇機如圖示舉起，等待直昇機停止轉動後檢視機頭方向，正確重心應落在機身（主軸附近）位置。

Adjust the frame's CG within +/- 60 degrees from level.
以水平線上下夾角 60° 內為適當的範圍來調整機體的重心。

18. FLIGHT ADJUSTMENT AND SETTING 飛行動作調整與設定

ALIGN

Please practice simulation flight before real flying 飛行前請事先熟練電腦模擬飛行







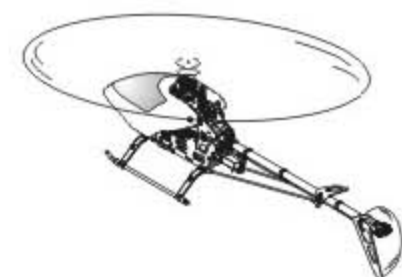

A safe and effective practice method is to use the transmitter flying on the computer through simulator software sold on the market. Do a simulation flight until you familiarize your fingers with the movements of the rudders, and keep practicing until the fingers move naturally.

1. Place the helicopter in a clear open field and the tail of helicopter point to yourself.
2. Practice to operate the throttle stick (as below illustration) and repeat practicing "Throttle high/low", "Aileron left/right", "Rudder left/right", and "Elevator up/down".
3. The simulation flight practice is very important, please keep practicing until the fingers move naturally when you hear operation orders being call out.

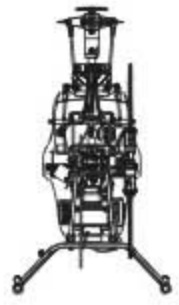
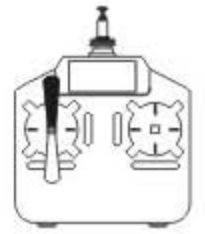
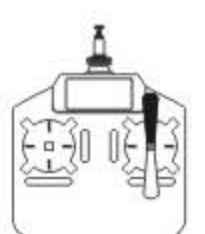
在還沒瞭解直昇機各動作的操控方式前，嚴禁實機飛行，請先進行電腦模擬飛行的練習，一種最有效、最安全的練習方式，就是透過市面販售的模擬軟體，以遙控器在電腦上模擬飛行，熟悉各種方向的操控，並不斷的重複，直到手指可熟練的控制各個動作及方向。

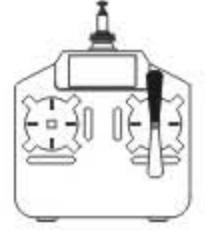
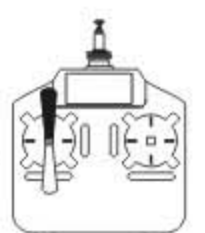
1. 將直昇機放在空曠的地方，並將直昇機的機尾對準自己。
2. 練習操作遙控器的各搖桿(各動作的操作方式如下圖)，並反覆練習油門高/低、副翼左/右、升降舵前/後及方向舵左/右操作方式。
3. 模擬飛行的練習相當重要，請重複練習直到不需思索，手指能自然隨著喊出的指令移動控制。

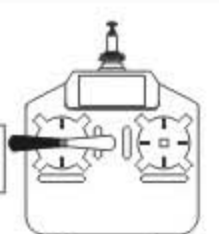

Mode 1	Mode 2	Illustration 圖示
 Aileron 副翼		 Move left 左移 ← Rotate left 左翻 ↶ Move right 右移 → Rotate right 右翻 ↷
 Elevator 升降/前後		 Fly forward 前進 ← Forward rotate 前翻 ↶ Fly backward 後退 → backward rotate 後翻 ↷
 Throttle 油門		 Ascent 上升 ↑ Descent 下降 ↓
 Rudder 方向		 Turn right 右旋 ↷ Turn left 左旋 ↶

Flight adjustment and notice 飛行調整與注意



- ⊙ Check if the screws are firmly tightened.
- ⊙ Check if the transmitter and receivers are fully charged.
- ⊙ 再次確認→螺絲是否鎖固?
- ⊙ 發射器和接收器電池是否足夠。



If there are other radio control aircraft at the field, make sure to check their frequencies and tell them what frequency you are using. Frequency interference can cause your model, or other models to crash and increase the risk of danger. 假使飛行場有其他遙控飛機，請確認他們的頻率，並告知他們你正在使用的頻率，相同的頻率會造成干擾導致失控和大大地增加風險。

★When arriving at the flying field.

★當抵達飛行場

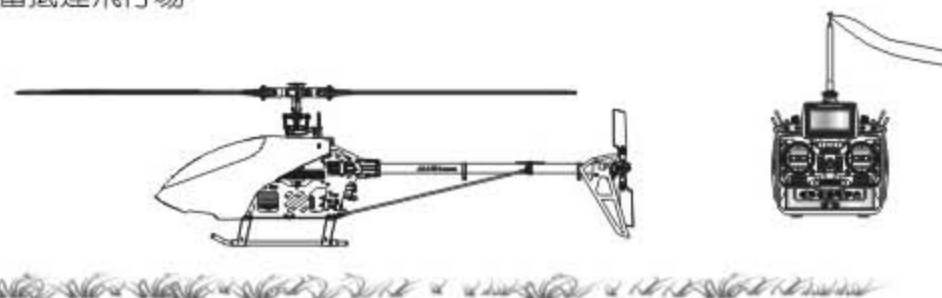

STARTING AND STOPPING THE MOTOR 啟動和停止馬達



First check to make sure no one else is operating on the same frequency. Then place the throttle stick at lowest position and turn on the transmitter. 首先確認附近沒有其他相同頻率的使用，然後打開發射器將油門搖桿推到低點。



Check if the throttle stick is set at the lowest position. 確認油門搖桿是在最低的位置。

Mode 1 Mode 2

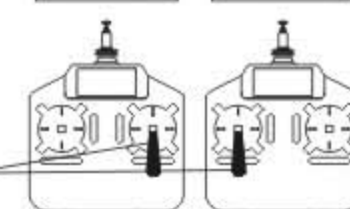

★Check the movement.
★動作確認



ON! Step1
First turn on the transmitter.
先開啟發射器

- ⊙ Are the rudders moving according to the controls?
- ⊙ Follow the transmitter's instruction manual to do a range test.
- ⊙ 方向舵是否隨著控制方向移動?
- ⊙ 根據發射器說明書進行距離測試。



ON! Step2
Connect to the helicopter power
接上直昇機電源

OFF! Step3
Reverse the above orders to turn off.
關閉電源時請依上述操作動作反執行。

This procedure is best performed on soft surfaces such as grass. The use of rubber skid stopper is recommended on hard surface to prevent vibration feedback from the ground to 3GX, resulting in over-corrections.

將直昇機置於柔軟地面上，建議硬地起飛腳架裝上避震墊圈。避免升空前腳架與過硬的地面震動太大反饋至機身上的3GX，影響無平衡翼系統升空前過度修正。

Rubber skid stoppers installed

裝上避震墊圈

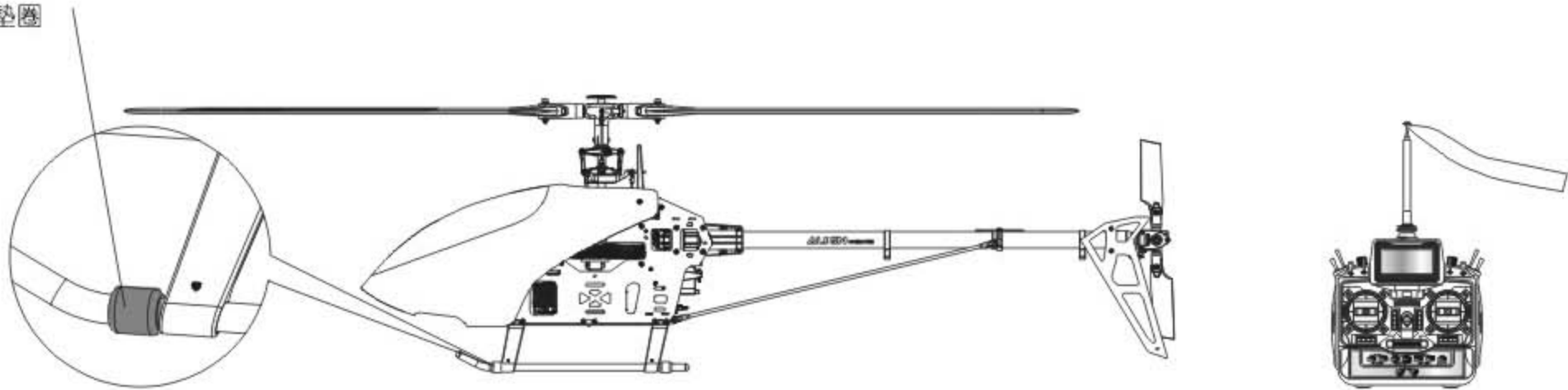

If swashplate should tilt prior to lift off, do not try to manually trim the swashplate level. This is due to vibration feedback to the 3GX, and will disappear once helicopter lifts off the ground. If manual trim is applied, helicopter will tilt immediately after lift off.

直昇機離地前，十字盤可能因3GX受震動的反饋，使十字盤有傾斜的情形，此時請勿刻意將十字盤修正為水平狀態，此現象只要離地升空時立即解除，可平穩升空；若刻意將十字盤修正為水平時，反而會造成感應器過度修正，一離地即偏往修正方向的危險。

Main rotor adjustments 主旋翼雙槳平衡調整

1. Before adjusting, apply a red piece of tape on one blade, or paint a red stripe with a marker or paint to identify on blade.
2. Raise the throttle stick slowly and stop just before the helicopter lifts-off ground. Look at the spinning blades from the side of the helicopter.
3. Look at the path of the rotor carefully. If the two blades rotate in the same path, it does not need to adjustment. If one blade is higher or lower than the other blade, adjust the tracking immediately.

1. 調整前先在其中一支主旋翼的翼端，貼上有顏色的貼紙或畫上顏色記號，方便雙槳調整辨識。
2. 慢慢的推起油門搖桿到高點並且停止，在直昇機離開地面前，從直昇機側邊觀察主旋翼轉動。
3. 仔細觀察旋翼軌跡(假如兩支旋翼移動都是相同軌跡，則不需要調整;可是如果一支旋翼較高或較低產生“雙槳”的情形時，則必須立刻調整軌跡)。

A. When rotating, the blade with higher path means the pitch too big. Please shorten pitch linkage rod (A) for regular trim.

B. When rotating, the blade with lower path means the pitch too small. Please lengthen pitch linkage rod (A) for regular trim.

A. 旋翼轉動時較高軌跡的主旋翼表示螺距(PITCH)過大，請調短連桿(A)修正。

B. 旋翼轉動時較低軌跡的主旋翼表示螺距(PITCH)過小，請調長連桿(A)修正。



Tracking adjustment is very dangerous, so please keep away from the helicopter at a distance of at least 5m.

調整軌跡非常危險，請於距離飛機最少5公尺的距離。

Incorrect tracking may cause vibrations. Please repeat adjusting the tracking to make sure the rotor is correctly aligned. After tracking adjustment, please check the pitch angle is approx. $+5^\circ$ when hovering.

不正確的旋翼軌跡會導致震動，請不斷重複調整軌跡，使旋翼軌跡精準正確。在調整軌跡後，確認一下Pitch角度在停旋時應為大約 $+5^\circ$ 。

Color mark 有標示記號的主旋翼

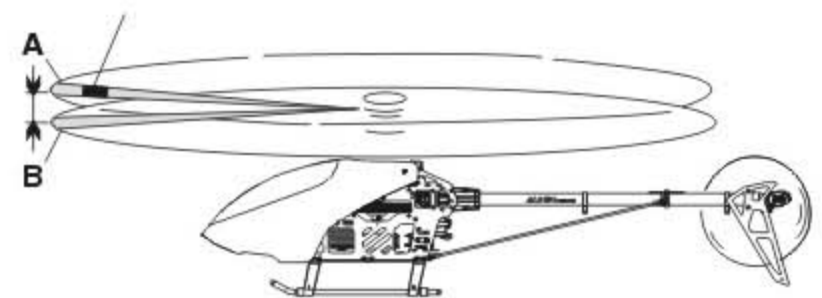

FLIGHT ADJUSTMENT AND NOTICE 飛行調整與注意

⊙ During the operation of the helicopter, please stand approximately 5m diagonally behind the helicopter.

⊙ 飛行時，請站在直昇機後方5公尺。



- ⊙ Make sure that no one or obstructions in the vicinity.
- ⊙ For flying safety, please carefully check if every movement and directions are correct when hovering.
- ⊙ 確認鄰近地區沒有人和障礙物。
- ⊙ 為了飛行安全，您必須先確認停懸時各項操控動作是否正常。



Do not attempt until you have some experiences with the operation of helicopter.

嚴禁無熟練操控飛行經驗者操控飛行。

STEP 1 THROTTLE CONTROL PRACTICE 油門控制練習

◎When the helicopter begins to lift-off the ground, slowly reduce the throttle to bring the helicopter back down. Keep practicing this action until you control the throttle smoothly.

◎當直昇機開始離地時，慢慢降低油門將飛機降下。
持續練習飛機從地面上升和下降直到你覺得油門控制很順。

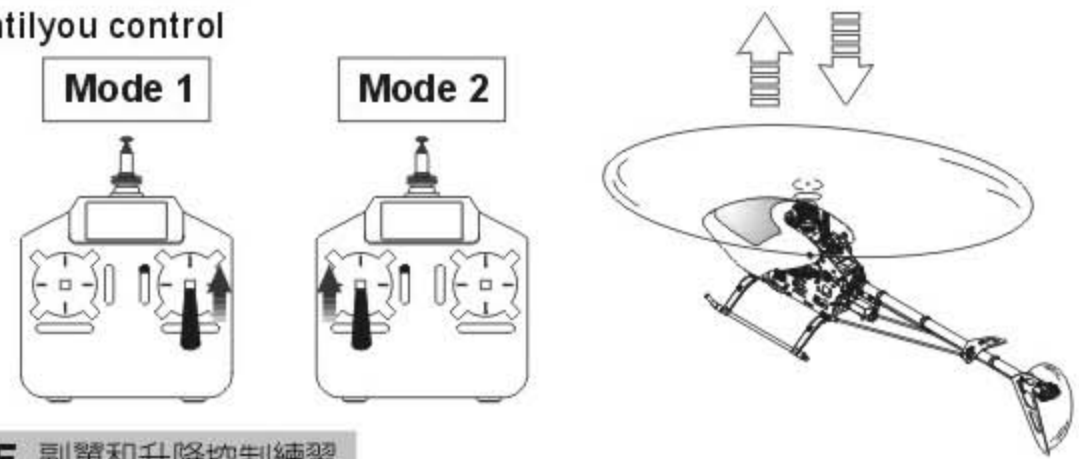

STEP 2 AILERON AND ELEVATOR CONTROL PRACTICE 副翼和升降控制練習

1. Raise the throttle stick slowly.
2. Move the helicopter in any direction back, forward, left and right, slowly move the aileron and elevator sticks in the opposite direction to fly back to its original position.

1. 慢慢升起油門搖桿。
2. 使直昇機依指示：移動向後/向前/向左/向右，慢慢的反向 移動副翼和升降搖桿並將直昇機開回到原來位置。

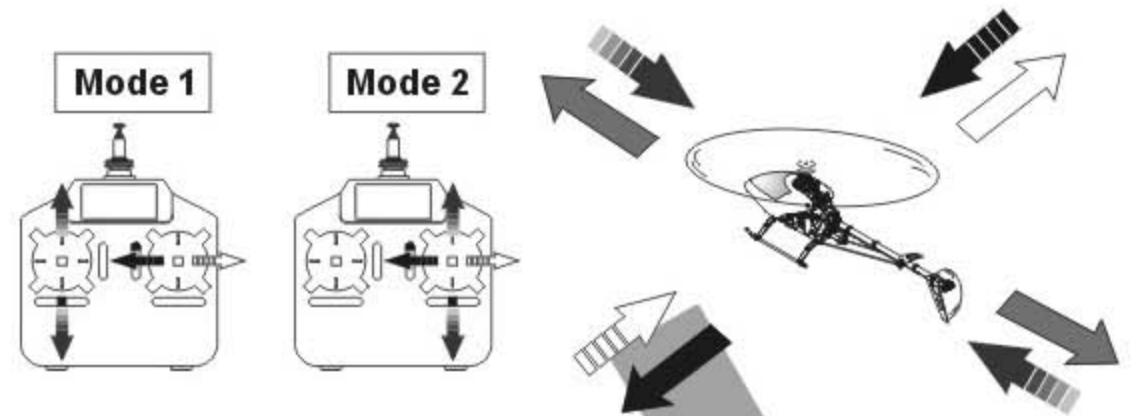

- ◎If the nose of the helicopter moves, please lower the throttle stick and land the helicopter. Then move your position diagonally behind the helicopter 5m and continue practicing.
- ◎If the helicopter flies too far away from you, please land the helicopter and move your position behind 5m and continue practicing.
- ◎當直昇機機頭偏移時，請降低油門並且降落，然後移動自己的位置到直昇機的正後方5公尺再繼續練習。
- ◎假如直昇機飛離你太遠，請先降落直昇機，並到直昇機後5公尺再繼續練習。

STEP 3 RUDDER CONTROL PRACTICING 方向舵操作練習

1. Slowly raise the throttle stick.
2. Move the nose of the helicopter to right or left, and then slowly move the rudder stick in the opposite direction to fly back to its original position.

1. 慢慢升起油門搖桿。
2. 將直昇機機頭移動左或右，然後慢慢反向移動方向舵搖桿並將直昇機飛回原本位置。

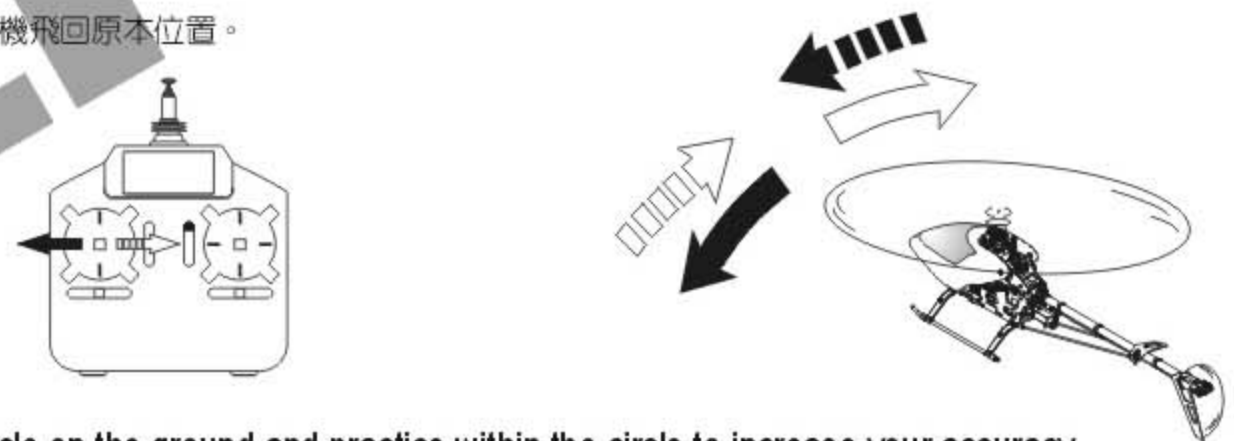

STEP 4

After you are familiar with all actions from Step1 to 3, draw a circle on the ground and practice within the circle to increase your accuracy.

◎You can draw a smaller circle when you get more familiar with the actions.

當你覺得 step1~3 動作熟悉了，在地上畫圈圈並在這個圈圈的範圍內練習飛行，以增加你操控的準確度。

◎當你更加習慣操作動作，你可以畫更小的圈圈。

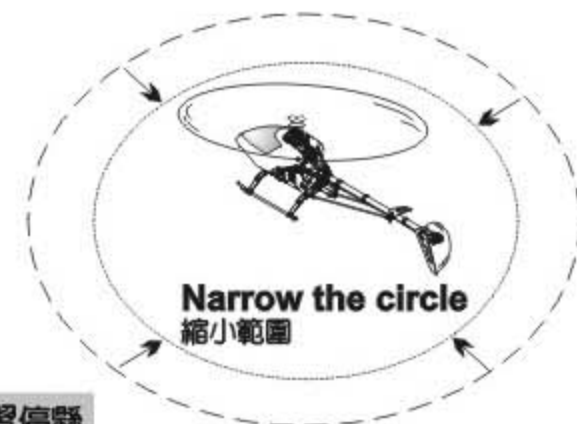

STEP 5 DIRECTION CHANGE AND HOVERING PRACTICE 改變直昇機方向和練習停懸

After you are familiar with Step1 to 4, stand at side of the helicopter and continue practicing Step1 to 4. Then repeat the Step1 to 4 by standing in front of the helicopter.

當你覺得step1~4動作熟悉了，站在面對直昇機側邊並繼續練習step1~4。之後，站在直昇機機頭前方重複步驟練習。

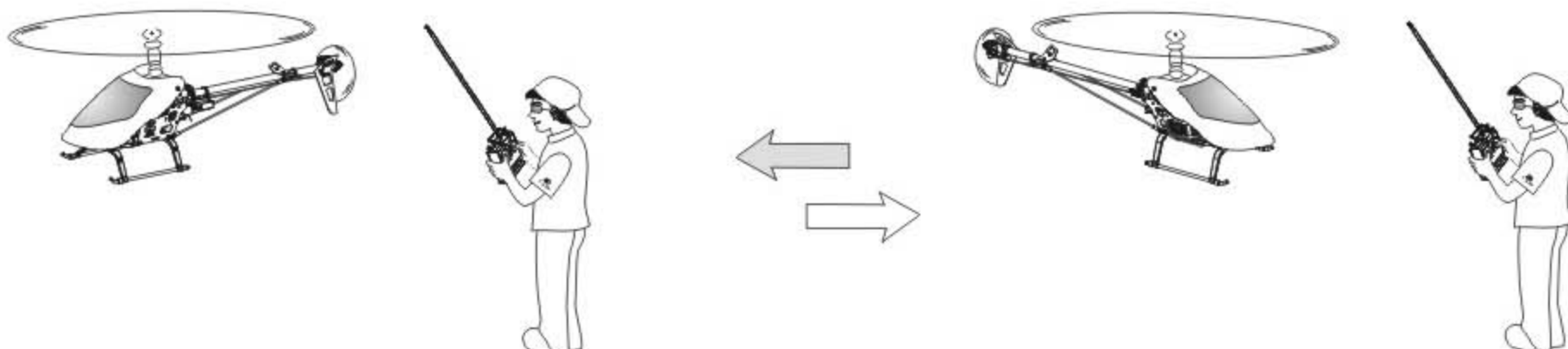

With the helicopter hovering, observe for any rapid left/right or forward/aft oscillations. If forward/aft oscillation is observed, land the helicopter, turn the ELE gain dial counterclockwise gradually, and test again. Do this until oscillation disappears.

先將直昇機以停懸飛行，觀察直昇機左右及前後是否有不正常快速抖動現象，如果前後有抖動情形，則逆時針調降升降舵感度調整旋鈕，以減少陀螺儀前後修正感度。

Set the dial to 12 o'clock position as starting point
建議初次飛行設於12點鐘方向

Elevator gain adjustment dial
升降舵感度調整旋鈕

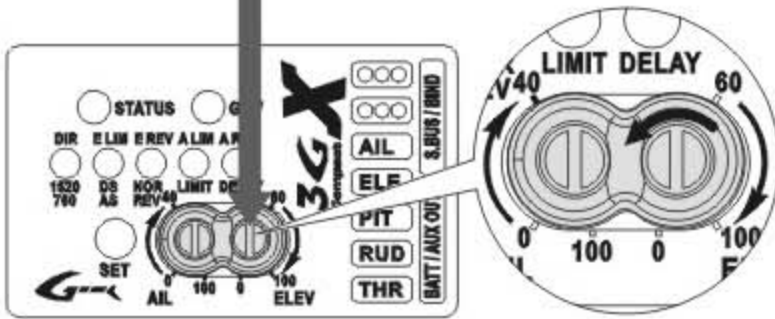

Decrease ELE gain
調降ELE感度

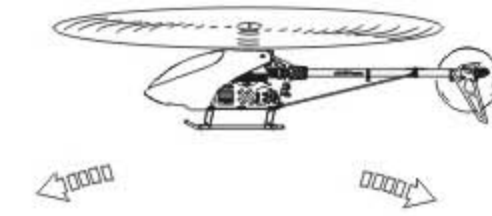

Forward/back oscillation
前後晃動



If left/right oscillation is observed, land the helicopter, turn the AIL gain dial counterclockwise gradually, and test again. Do this until oscillation disappears.

如果為左右抖動，逆時針調降副翼感度調整旋鈕，以減少陀螺儀左右修正感度。

Set the dial to 12 o'clock position as starting point
建議初次飛行設於12點鐘方向

Aileron gain adjustment dial
副翼感度調整旋鈕

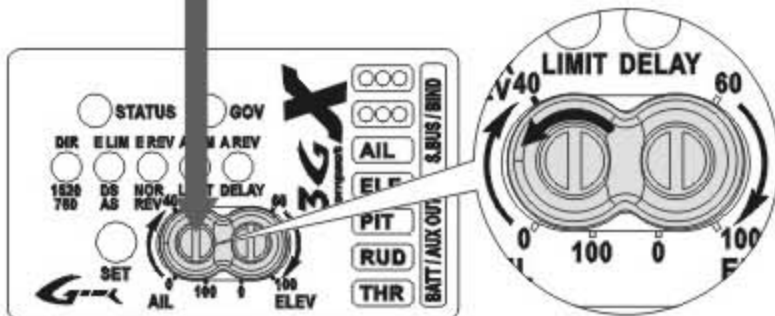

Decrease AIL gain
調降AIL感度



Left/right oscillation
左右晃動



FORWARD STRAIGHT LINE FLIGHT 前進直線航道飛行

Put the helicopter into fast forward flight from hovering. If similar oscillation is observed, reduce the elevator gyro gain. If the helicopter pitches up, or responds slowly, increase the elevator gyro gain. Repeat test until the oscillation is eliminated. Similar method is used for aileron gyro gain. After gyro gain adjustments are completed, the helicopter cyclic rate can be tuned using transmitter's swash AIL and ELE mixing ratio. Higher the percentage, faster the roll/flip rate. Exponential can also be added on the transmitter to soften the sensitivity for stable hover.

停懸完後可快速前進飛行，同樣的如果有不正常抖動時，請將升降舵感度調小，飛行時如果有機頭向上仰起或反應緩慢現象時，請將感度調大，重複測試將感度調整至最理想值，同樣方式可調整副翼感度旋鈕。調整完陀螺儀感度，可依據飛行習慣調整Swash AIL及ELE比率，比率調整越大，前後及左右滾轉速度越快，使用者也可依據個人經驗調整舵面EXPI以增加停旋穩定性。完成所有調整後，就可享受Flybarless所提供低速飛行的穩定性及高速時的靈活性。



Forward Flight
前進飛行

Using Futaba 12ZH transmitter as an example 以Futaba 12ZH遙控器為例

	With emphasis on stability 穩定特性	With emphasis on agility 靈活特性
Main blade pitch Settings(Collective Pitch Settings) 主旋翼螺距設定 (集體螺距設定)	Main blade pitch : 10°~12° 主旋翼螺距 : 10°~12° swash pitch : 38%~43%	Main blade pitch : 12°~14° 主旋翼螺距 : 12°~14° swash pitch : 43%~48%
Cyclic pitch settings (Adjust while in DIR mode using AIL/ELE swash AFR) 循環螺距設定 (須在DIR模式下設定)	Cyclic Pitch 12° 循環螺距 12° swash Aileron : 65% Elevator : 65%	Cyclic Pitch 14° 循環螺距 14° swash Aileron : 75% Elevator : 75%
Aileron and Elevator swashplate mixing ratio settings 副翼與升降舵滾轉速率設定	swash Aileron : ≤65% Elevator : ≤65%	swash Aileron : ≤75% Elevator : ≤75%
Aileron and Elevator gyro gain settings 副翼與升降舵鎖定感度設定	12 o'clock direction(50%) 12點鐘方向(50%)	11 o'clock direction(40%) 11點鐘方向(40%)



While in DIR setup mode, the transmitter's CCPM swash mixing values for aileron and elevator represent CYCLIC pitch values. These values affect the cyclic roll rates on the aileron and elevator in flying condition. Higher values translate to faster cyclic roll rates. If cyclic roll rate is not improved with increased swash mixing values, this is due to insufficient cyclic pitch. When this happens, cyclic pitch can be increased through the flybarless setup procedure. Maximum cyclic pitch should be limited at 14 degrees.

遙控器上的CCPM十字盤混控SWASH於"DIR"模式設定循環螺距時，Aileron與Elevator比率值的大小代表循環螺距角度的大小，比率愈高循環螺距的角度愈大；而在飛行模式下Aileron與Elevator比率值的大小代表滾轉速率的大小，比率愈高滾轉速率愈快，但若比率調高仍無法提升滾轉速率時表示循環螺距不足，請進入無平衡翼系統設定模式，將循環螺距加大，但以不超過14°為限。

	Problem 狀況	Cause 原因	Solution 對策
Blade Tracking 雙槳平衡	Tracking is Off 雙槳	Pitch linkage rods are not even length PITCH連桿長度調整不平均	Adjust length of pitch linkage rods (A) 調整連桿(A)長度
Hover 停懸	Head speed too low 主旋翼轉速偏低	Excessive pitch 主旋翼的PITCH偏高	Adjust pitch linkage rods (A) to reduce pitch by 4 to 5 degrees. Hovering headspeed should be around 1900RPM. 調整連桿(A)調低Pitch約+4~5度 (停懸時主旋翼需為約1900RPM)
		Hovering throttle curve is too low 停懸點油門曲線過低	Increase throttle curve at hovering point on transmitter (around 65%) 調高停懸點油門曲線(約65%)
	Head speed too high 主旋翼轉速偏高	Not enough pitch 主旋翼的PITCH偏低	Adjust pitch linkage rods (A) to increase pitch by 4 to 5 degrees. Hovering headspeed should be around 1900RPM. 調整連桿(A)調高Pitch約+4~5度 (停懸時主旋翼需為約1900RPM)
		Hovering throttle curve is too high 停懸點油門曲線過高	Decrease throttle curve at hovering point on transmitter (around 65%) 調低停懸點油門曲線(約65%)
Rudder Response 尾舵反應	Drifting of tail occurs during hovering, or delay of rudder response when centering rudder stick. 停懸時尾翼向某一邊偏移，或撥動方向舵並回復到中立點時，尾翼產生延遲，無法停頓在所控制位置上。	Rudder neutral point improperly set 尾中立點設定不當	Reset rudder neutral point 重設尾中立點
	Tail oscillates (hunting, or wags) at hover or full throttle 停懸或全油門時尾翼左右來回搖擺。	Rudder gyro gain too low 尾舵陀螺儀感度偏低	Increase rudder gyro gain 增加尾舵陀螺儀感度
		Rudder gyro gain too high 尾舵陀螺儀感度偏高	Reduce rudder gyro gain 降低尾舵陀螺儀感度
Oscillation during flight 飛行抖動	Forward/aft oscillation when elevator is applied 升降舵打舵動作時，機體前後抖動	Elevator gyro gain too high. 升降舵陀螺感度偏高，產生追蹤現象	Turn the ELE gain dial on control box counterclockwise, 10 degrees at a time until oscillation is eliminated. 逆時針調整控制器上的升降舵感度調整旋鈕，以每次調整約10度的方式，調整至適當位置
	Helicopter front bobbles (nods) during forward flight. 直線飛行時，機頭點頭	Worn servo, or slack in control links 伺服器老化，控制結構有虛位	Replace servo, ball link, or linkage balls. 更換伺服器、連桿頭、球頭
	Left/right oscillation when aileron is applied 副翼打舵動作時，機體左右抖動	Aileron gyro gain too high 副翼陀螺感度偏高，產生追蹤現象	Turn the AIL gain dial on control box counterclockwise, 10 degrees at a time until oscillation is eliminated. 逆時針調整控制器上的副翼感度調整旋鈕，以每次調整約10度的方式，調整至適當位置
	Elevator input causes helicopter to drift 升降舵動作飄移	Worn servo, or slack in control links 伺服器老化，控制結構有虛位	Replace servo, ball link, or linkage balls. 更換伺服器、連桿頭、球頭
Drifting during flight 飛行飄移	Helicopter pitches up during forward flight 直線飛行機頭上揚	Elevator gyro gain too low 升降舵陀螺感度偏低	Turn the ELE gain dial on control box clockwise, 10 degrees at a time until drifting is eliminated. 順時針調整控制器上的升降舵感度調整旋鈕，以每次調整約10度的方式，調整至適當位置
	Aileron input causes helicopter to drift 副翼動作飄移	Aileron gyro gain too low 副翼陀螺感度偏低	Turn the AIL gain dial on control box clockwise, 10 degrees at a time until drifting is eliminated. 順時針調整控制器上的升降舵感度調整旋鈕，以每次調整約10度的方式，調整至適當位置
Control Response 動作反應	Slow Forward/Aft/Left/Right input response 前後左右飛行動作反應偏慢	Roll rate too low 滾轉速率偏低	Increase the swashplate AFR in transmitter 調整遙控器內Swash AFR值，提高滾轉速率
		Roll rate still slow after swash afr adjustment, cyclic pitch too low 已經調整滾轉速率仍然滾動偏慢，循環角度偏低	Go back through the DIR setup procedure and increase the cyclic pitch. 重新進入DIR模式，設定較大的循環螺距角度
	Sensitive Forward/Aft/Left/Right input response 前後左右飛行動作反應偏快	Roll rate too high 滾轉速率偏快	Decrease the swashplate AFR in transmitter 調整遙控器內Swash AFR值，降低滾轉速率
		Roll rate still too fast after swash afr adjustment, cyclic pitch too high 已經調整滾轉速率仍然滾動偏快，循環角度偏高	Go back through the DIR setup procedure and decrease the cyclic pitch. 重新進入DIR模式，設定較小的循環螺距角度

If above solution does not resolve your issues, please check with experienced pilots or contact your Align dealer.

※在做完以上調整後，仍然無法改善情況時，應立即停止飛行並向有經驗的飛手諮詢或連絡您的經銷商。

Q&A 1 **Pitches up during fast forward flight.**
 (1) Elevator gyro gain too low, increase the elevator gain by gradually turning the ELE dial clockwise.
 (2) Elevator trim not centered. Check if helicopter is tilting backwards during hover.
 快速飛行時直昇機機頭會上揚？
 (1) ELE感度不足，請稍微將ELE感度旋鈕順時針方向調高。
 (2) ELE中立點不對，請測試停懸時，直昇機中立點是否朝後。

Q&A 2 **Insufficient gain during flight, but increasing gain results in oscillation.**
 (1) Check and resolve possible mechanical vibration from helicopter.
 (2) Use softer 3GX mounting foam, or double up the stock 3GX foam.
 (3) Relocate the 3GX to location less prone to vibration.
 飛行時感度不足，將感度調高直昇機卻會抖動？
 (1) 檢查直昇機是否有異常震動，如果是請先修復機體。
 (2) 用材質較軟或兩片雙面膠泡棉固定3GX。
 (3) 將3GX換裝於直昇機較不震動的位置。

Q&A 3 **Drifting during 3D maneuvers.**
 (1) Increase AIL and ELE gain by turning both dials clockwise.
 (2) Check if cyclic servos are too slow (minimum 0.08sec / 60 degrees)
 3D飛行時有飄移現象？
 (1) 將升降與副翼感度旋鈕順時針方向調高。
 (2) 檢查推動十字盤的伺服器是否過慢（建議選擇動作速度0.08sec/60度以內規格）。

Q&A 4 **Unstable hover, control inputs are too sensitive.**
 Decrease the aileron and elevator ATV(AFR) value on the transmitter. For CCPM machines, decrease swashplate mixing percentage on the transmitter. In addition, exponential can be added to aileron and elevator channels.
 停懸時不穩定，有動作過靈敏現象？
 可調低遙控器AIL及ELE的ATV (AFR) 值（CCPM模式，請調降Swash比率），並增加EXP的設定，以提高停懸的穩定性。

Q&A 5 **After increasing the ATV(AFR) of aileron and elevator, 3D roll rates are still not enough.**
 Go back through the DIR setup procedure and use larger cyclic pitch.
 已調高AIL及ELE的ATV (AFR)，但3D飛行的滾轉速率卻無法提高？
 重新進入DIR模式，設定較大的循環螺距角度。

Q&A 6 **Helicopter oscillates after fast forward flight or after tumbles.**
 (1) Gradually reduce both AIL and ELE gain by turning them counterclockwise, 10 degrees at a time.
 (2) Use harder head dampener.
 直昇機高速飛行或滾轉後停止時，機身會有輕微抖動現象？
 (1) 逆時針調整3GX上的升降舵感度調整旋鈕，以每次調整約10度的方式，調整至適當位置。
 (2) 主旋翼橫軸及主軸連結的橡膠過軟，請換用較硬的橡膠。

Q&A 7 **While in flybarless setup mode, unable to complete ELE/AIL endpoint and reverse settings.**
 Disable all trims/subtrims on the transmitter.
 進入Flybarless設定，無法順利完成ELE、AIL行程、ELE或AIL的REV燈號？
 未取消遙控器的內外微調。

Q&A 8 **Incorrect CCPM mixing after initial flybarless setup.**
 (1) Trim/subtrims not zeroed out on transmitter.
 (2) After any trim adjustments are done on transmitter, the initial flybarless setup procedure need to be performed again.
 (3) Please turn off the swash ring, Linkage Compensation, Swash Mix, Mixing, Acceleration and other collective mixing functions in the transmitter.
 完成Flybarless設定，但CCPM混控動作不正常？
 (1) 進入Flybarless設定時未將外微調歸零。
 (2) 遙控器變更內微調，未重新進行Flybarless設定。
 (3) 請關閉遙控器內Swash ring、Linkage Compensation、Swash Mix、Mixing、Acceleration等混控功能。

Q&A 9 **3GX flybarless system unable to power up.**
 (1) Check proper voltage source.
 (2) Check AIL/ELE/PIT connections between flybarless control unit and receiver.
 (3) Check the power connection of 3GX and receiver.
 3GX Flybarless無法開機？
 (1) 檢查系統電源是否正確。
 (2) 檢查AIL、ELE及PIT的訊號線和接收器是否正常連接。
 (3) 檢查3GX與接收器間電源線是否正常連接。

Q&A 10 **3GX flybarless system powers up with LED flashing, but swashplate did not jump 3 times, pitch is locked, unable to complete the initialization process.**
 (1) Possible movement during initialization process. Make sure helicopter is absolutely stationary.
 (2) If STATUS LED flashes red, check the connection between controller and receiver.
 3GX Flybarless開機後閃燈正常，十字盤未跳動，PIT被鎖定，無法順利完成開機動作？
 (1) 開機時直昇機必須完全靜止，才可順利開機。
 (2) 檢查如果STATUS紅綠燈號一直閃爍，請檢查遙控器與接收器是否正常。

Q&A 11 **I noticed swashplate tilts slightly at extreme pitch due to servo interactions, should I make efforts to level it out?**
 No. Level the swashplate at 0 degrees using subtrims ONLY in DIR setup mode. (please refer to page 23 step 1.3)
 End point swashplate interactions are automatically compensated by the 3GX system while in flight.
 十字盤移動到最高與最低位置時會有些微傾斜，我能嘗試將它修正調整到水平嗎？
 否。在DIR模式時利用內微調(Subtrims)將十字盤0度時調整至水平(參閱第23頁 步驟1.3)，實際飛行時，3GX系統會自動修正十字盤的混控位差。

Q&A 12 **What adjustments can I make on the transmitter after the DIR setup has been completed?**
 You can adjust the trim tabs, dual rates, exponential, collective pitch, and ail/elev swash AFR (for roll rate). Again do NOT adjust the subtrims unless followed by repeating of DIR setup steps.
 在離開DIR模式後，有哪些調整功能是我能使用的？
 一般開機模式下，你仍然可以使用以下幾個功能調整直昇機：舵面大小動(dual rates, exponential)、集體螺距(collective pitch)、升降/副翼混控速率(ail/elev swash AFR (for roll rate))。

Q&A 13 **During step 5 of DIR setup mode, only aileron swash mixing was mentioned. Should I set elevator swash mixing as well?**
 No. The 3GX system automatically calculates a cyclic ring based on the aileron swash mix percentage. Setting of elevator swash mix has no affect on the 3GX system. Set the cyclic pitch by the aileron swash mix & just use the same value for elevator.
 在步驟五-循環螺距設定時，為何只測量副翼的角度？
 3GX系統在實際飛行時，會自動給定十字盤一個限圈運行，所以在測量副翼循環螺距角度後，設定相同數值的升降循環角度即可。

ALIGN

Specifications & Equipment/規格配備:

Length/機身長:1042mm

Height/機身高:356mm

Main Blade Length/主旋翼長:520mm(550mm Option另購)

Main Rotor Diameter/主旋翼直徑:1188mm(1248mm)

Tail Rotor Diameter/尾旋翼直徑:254mm

Motor Pinion Gear/馬達齒輪:16T

Main Drive Gear/傳動主齒:170T

Autorotation Tail Drive Gear/尾驅動主齒:131T

Tail Drive Gear/尾翼傳動齒:34T

Drive Gear Ratio/齒輪傳動比:1:10.62:3.85

Weight/空機重:1800g

Flying Weight/全配重:Approx. 2800g

