

DOMINATOR T-REX 450L Super Combo INSTRUCTION MANUAL

使用說明書

RH45E10XT

ALIGN



3GX Compact



3Axs MEMS 12bit APs 5.BUS Easy Energy Stable GOV G-TWO (250-300) GPS (2.4-2.6) RoHS

Thank you for buying ALIGN products. The T-REX 450L DOMINATOR is the latest technology in Rotary RC models. Please read this manual carefully before assembling and flying the new T-REX 450L DOMINATOR helicopter. We recommend that you keep this manual for future reference regarding tuning and maintenance.

承蒙閣下選用亞拓遙控世界系列產品，謹表謝意。進入遙控世界之前必須告訴您許多相關的知識與注意事項，以確保您能夠在學習的過程中較得心應手。在開始操作之前，請務必詳閱本說明書，相信一定能夠給您帶來相當大的幫助，也請您妥善保管這本說明書，以作為日後參考。



Contents

1	INTRODUCTION 前言
1~2	SAFETY NOTES 安全注意事項
3	EQUIPMENT REQUIRED FOR ASSEMBLY 自備設備
3	PACKAGE ILLUSTRATION 包裝說明
4	SAFETY CHECK BEFORE FLYING 飛行前安全檢查重要事項
5~15	ASSEMBLY SECTION 組裝說明
16	EQUIPMENT INSTALLATION 各項設備配置圖
17	BATTERY INSTALLATION ILLUSTRATION 電池安裝示意圖
17	CANOPY ASSEMBLY 機頭罩安裝
18	EQUIPMENT ILLUSTRATION 電子設備建議配置圖示
19	SERVO SETTING AND ADJUSTMENT 伺服器設定調整
19	ADJUSTMENTS FOR GYRO AND TAIL NEUTRAL SETTING 陀螺儀與尾翼中立點設定調整
20	PITCH AND THROTTLE SETTING 主旋翼螺距與油門設定
21~32	3GX FLYBARLESS MANUAL 3GX 無平衡翼系統使用說明
33	3GX V4.0 SETUP TABLE 簡易設定表
34	POWER COLLOCATION REFERENCE 原裝動力數據參考表
34~37	RCE-BL45X BRUSHLESS SPEED CONTROLLER INSTRUCTION MANUAL 無刷调速器使用說明
38~39	3GX FLYBARLESS PREFLIGHT CHECK 飛行前測試程序
39~42	FLIGHT ADJUSTMENT AND SETTING 飛行動作調整與設定
43	3GX FLYBARLESS FLIGHT TEST PROCEDURE 飛行測試程序
44	TROUBLESHOOTING 飛行中狀況排除
45~46	Q & A 問與答

Thank you for buying ALIGN Products. The T-REX 450L DOMINATOR Helicopter is designed as an easy to use, full featured Helicopter R/C model capable of all forms of rotary flight. Please read the manual carefully before assembling the model, and follow all precautions and recommendations located within the manual. Be sure to retain the manual for future reference, routine maintenance, and tuning. The T-REX 450L DOMINATOR is a new product developed by ALIGN. It features the best design available on the R/C helicopters market to date, providing flying stability for beginners, full aerobatic capability for advanced fliers, and unsurpassed reliability for customer support.

感謝您選購亞拓產品，為了讓您容易方便的使用 T-REX 450L DOMINATOR 直昇機，請您詳細的閱讀完這本說明書之後再進行組裝以及操作這台直昇機，同時請您妥善的保存這本說明書、作為日後進行調整以及維修的參考。T-REX 450L DOMINATOR 是由亞拓自行研發的新產品，不論您是需求飛行穩定性的初學者或是追求性能的飛行愛好者。T-REX 450L DOMINATOR 將是您最佳的選擇。

WARNING LABEL LEGEND 標誌代表涵義

	Do not attempt under any circumstances. 在任何禁止的環境下，請勿嘗試操作。
	Mishandling due to failure to follow these instructions may result in damage or injury. 因為疏忽這些操作說明，而使用錯誤可能造成財產損失或嚴重傷害。
	Mishandling due to failure to follow these instructions may result in danger. 因為疏忽這些操作說明，而使用錯誤可能造成危險。

IMPORTANT NOTES 重要聲明

R/C helicopters, including the T-REX 450L DOMINATOR are not toys. R/C helicopter utilize various high-tech products and Technologies to provide superior performance. Improper use of this product can result in serious injury or even death. Please read this manual carefully before using and make sure to be conscious of your own personal safety and the safety of others and your environment when operating all ALIGN products. Manufacturer and seller assume no liability for the operation or the use of this product. Intended for use only by adults with experience flying remote control helicopters at a legal flying field. After the sale of this product we cannot maintain any control over its operation or usage.

As the user of this product, you are solely responsible for operating it in a manner that does not endanger yourself and others or result in damage to the product or the property of others.

T-REX 450L DOMINATOR 遙控直昇機並非玩具，它是結合了許多高科技產品所設計出來的休閒用品，所以商品的使用不當或不熟悉都可能會造成嚴重傷害甚至死亡，使用之前請務必詳讀本說明書，勿輕忽並注意自身安全。注意！任何遙控直昇機的使用，製造商和經銷商是無法對使用者於零件使用的損耗異常或組裝不當所發生之意外負任何責任，本產品是提供給有操作過模型直昇機經驗的成人或有相當技術的人員在旁指導於當地合法遙控飛行場飛行，以確保安全無虞下操作使用，產品售出後本公司將不負任何操作和使用控制上的任何性能與安全責任。

做為本產品的使用者，您，是唯一對於您自己操作的環境及行為負全部的責任之人。

We recommend that you obtain the assistance of an experienced pilot before attempting to fly our products for the first time. A local expert is the best way to properly assemble, setup, and fly your model for the first time. T-REX 450L DOMINATOR requires a certain degree of skill to operate, and is a consumer item. Any damage or dissatisfaction as a result of accidents or modifications are not covered by any warranty and cannot be returned for repair or replacement. Please contact our distributors for free technical consultation and parts at discounted rates when you experience problems during operation or maintenance.

As Align Corporation Limited has no control over use, setup, final assembly, modification or misuse, no liability shall be assumed nor accepted for any resulting damage or injury. By the act of use, setup or assembly, the user accepts all resulting liability.

模型商品屬於需高操作技術且為消耗性之商品，如經拆裝使用後，會造成不等情況零件損耗，任何使用情況所造成商品不良或不滿意，將無法於保固條件內更換新品或退貨，如遇有使用操作維修問題，本公司全省分公司或代理商將提供技術指導、特價零件供應服務。對使用者的不當使用、設定、組裝、修改、或操作不良所造成的破損或傷害，本公司無法控制及負責。任何使用、設定、組裝、修改、或操作不良所造成的破損、意外或傷害，使用者應承擔全部責任。

2. SAFETY NOTES 安全注意事項



- Fly only in safe areas, away from other people. Do not operate R/C aircraft within the vicinity of homes or crowds of people. R/C aircraft are prone to accidents, failures, and crashes due to a variety of reasons including, lack of maintenance, pilot error, and radio interference. Pilots are responsible for their actions and damage or injury occurring during the operation or as a result of R/C aircraft models.
- Prior to every flight, carefully check rotorhead spindle shaft screws and tail blade grip screws, linkage balls and screws, ensure they are firmly secured.
- 遙控模型飛機、直昇機屬高危險性商品，飛行時務必遠離人群，人為組裝不當或機件損壞、電子控制設備不良，以及操控上的不熟悉、都有可能導致飛行失控損傷等不可預期的意外，請飛行者務必注意飛行安全，並需了解自負疏忽所造成任何意外之責任。
- 每趟飛行前須仔細檢查，主旋翼夾座橫軸螺絲、尾旋翼夾座螺絲，以及機身各部位球頭、螺絲，確實上膠鎖緊才能昇空飛行。



LOCATE AN APPROPRIATE LOCATION 遠離障礙物及人群

R/C helicopters fly at high speed, thus posing a certain degree of potential danger. Choose a legal flying field consisting of flat, smooth ground without obstacles. Do not fly near buildings, high voltage cables, or trees to ensure the safety of yourself, others and your model. For the first practice, please choose a legal flying field. Do not fly your model in inclement weather, such as rain, wind, snow or darkness.

直昇機飛行時具有一定的速度，相對的也潛在著危險性，場地的選擇也相對的重要，請遵守當地法規到合法遙控飛行場地飛行。務必選擇在空曠合法專屬飛行場地，並必須注意周遭有沒有人、高樓、建築物、高壓電線、樹木等等，避免操控的不當造成自己與他人財產的損壞。請勿在下雨、打雷等惡劣天氣下操作，以確保本身及機體的安全。



NOTE ON LITHIUM POLYMER BATTERIES 鋰聚電池注意事項

Lithium Polymer batteries are significantly more volatile than alkaline or Ni-Cd/Ni-MH batteries used in RC applications. All manufacturer's instructions and warnings must be followed closely. Mishandling of Li-Po batteries can result in fire. Always follow the manufacturer's instructions when disposing of Lithium Polymer batteries.

鋰聚電池跟一般在RC使用的鹼性電池、鎳鎘電池、鎳氫電池比較起來是相對危險的。請嚴格遵守鋰聚電池說明書之使用注意事項。不恰當使用鋰聚電池，可能造成火災並傷及生命財產安全，切勿大意！

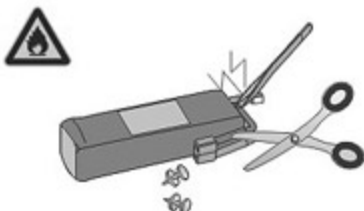

PREVENT MOISTURE 遠離潮濕環境

R/C models are composed of many precision electrical components. It is critical to keep the model and associated equipment away from moisture and other contaminants. The introduction or exposure to water or moisture in any form can cause the model to malfunction resulting in loss of use, or a crash. Do not operate or expose to rain or moisture.

直昇機內部也是由許多精密的電子零組件組成，所以必須絕對的防止潮濕或水氣，避免在浴室或雨天時使用，防止水氣進入機身內部而導致機件及電子零件故障而引發不可預期的意外！



PROPER OPERATION 勿不當使用本產品

Please use the replacement of parts on the manual to ensure the safety of instructors. This product is for R/C model, so do not use for other purpose.

請勿自行改造加工，任何的升級改裝或維修，請使用亞拓產品目錄中的零件，以確保結構的安全。請確認於產品限內操作，請勿過載使用，並勿用於安全、法令外其它非法用途。



OBTAIN THE ASSISTANCE OF AN EXPERIENCED PILOT 避免獨自操控

Before turning on your model and transmitter, check to make sure no one else is operating on the same frequency. Frequency interference can cause your model, or other models to crash. The guidance provided by an experienced pilot will be invaluable for the assembly, tuning, trimming, and actual first flight or unforeseen danger may happen. (Recommend you to practice with computer-based flight simulator.)

至飛行場飛行前，需確認是否有相同頻率的同好正進行飛行，因為開啟相同頻率的發射器將導致自己與他人立即干擾等意外危險。遙控飛機操控技巧在學習初期有著一定的難度，要盡量避免獨自操作飛行，需有經驗的人士在旁指導，才可以操控飛行，否則將可能造成不可預期的意外發生。(勤練電腦模擬器及老手指導是入門必要的選擇)

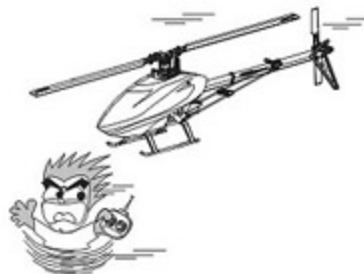

SAFE OPERATION 安全操作

Operate this unit within your ability. Do not fly under tired condition and improper operation may cause in danger. Never take your eyes off the model or leave it unattended while it is turned on. Immediately turn off the model and transmitter when you have landed the model.

請於自己能力內及需要一定技術範圍內操作這台直昇機，過於疲勞、精神不佳或不當操作，意外發生風險將可能提高。不可在視線範圍外進行，降落後也請馬上關掉直昇機和遙控器電源。



ALWAYS BE AWARE OF THE ROTATING BLADES 遠離旋轉中零件

During the operation of the helicopter, the main rotor and tail rotor will be spinning at a high rate of speed. The blades are capable of inflicting serious bodily injury and damage to the environment. Be conscious of your actions, and careful to keep your face, eyes, hands, and loose clothing away from the blades. Always fly the model a safe distance from yourself and others, as well as surrounding objects.

直昇機主旋翼與尾旋翼運轉時會以高轉速下進行，在高轉速下的旋翼會造成自己與他人在身體上或環境上的嚴重損傷，請勿觸摸運轉中的主旋翼與尾旋翼，並保持安全距離以避免造成危險及損壞。







KEEP AWAY FROM HEAT 遠離熱源

R/C models are made of various forms of plastic. Plastic is very susceptible to damage or deformation due to extreme heat and cold climate. Make sure not to store the model near any source of heat such as an oven, or heater. It is best to store the model indoors, in a climate-controlled, room temperature environment.











遙控飛機多半是以PA纖維或聚乙烯、電子商品為主要材質，因此要盡量遠離熱源、日曬，以避免因高溫而變形甚至熔毀損壞的可能。

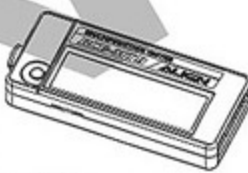

RADIO TRANSMITTER AND ELECTRONIC EQUIPMENT REQUIRED FOR ASSEMBLY 自備遙控及電子設備

 Transmitter (6-channel or more, helicopter system) 發射器 (六動以上直昇機模式遙控器)	 Receiver (7-channel or more) 接收器 (七動以上)	 or 或 Remote receiver 衛星天線
 22.2V 6S 1100~1400mAh Li-Po Battery x 1 22.2V 6S 1100~1400mAh Li-Po 電池 x 1	 Balance Charger RCC-3SX 分壓充電器 RCC-3SX	

ADDITIONAL TOOLS REQUIRED FOR ASSEMBLY 自備工具

 Swashplate Leveler 十字盤調整器	 Digital Pitch Gauge 電子螺距規	 Multi-function Tester Voltmeter/Servo Diagnosis 多功能檢測計 電池電壓 / 伺服器檢測				
 Phillips Screw Driver 十字螺絲起子 φ 3.0 / φ 1.8mm	 Cutter Knife 刀子	 Hexagon Screw Driver 六角螺絲起子 3mm/2.5mm/2mm/1.5mm	 Needle Nose Pliers 尖嘴鉗	 Oil 潤滑油	 CA 瞬間膠	 R48 軸承膠

4.PACKAGE ILLUSTRATION 包裝說明

450HB17 450HB22 450HB21 450HB19 450HT19 450HG1	Canopy 機頭罩	360 Carbon fiber blade x 1set 360 碳纖維主旋翼 x 1 組	3GX Flybarless System 3GX 無平衡翼系統	460MX (1800KV) Brushless motor x 1 460MX (1800KV) 無刷馬達 x 1 RCE-BL45X Brushless ESC x 1 RCE-BL45X 無刷定速調速器 x 1 DS525M Digital Servo x 1 DS525M 數位伺服器 x 1 DS430M Digital Servo x 3 DS430M 數位伺服器 x 3
---	----------------------	--	--	---

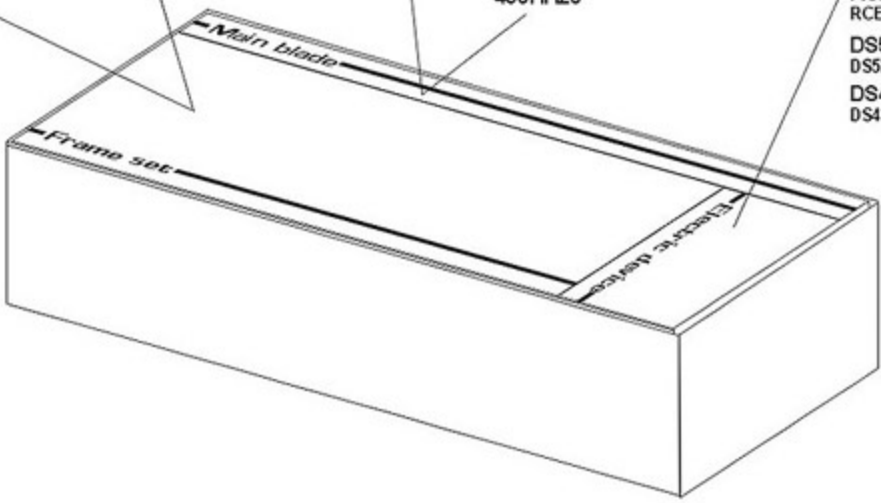

CAREFULLY INSPECT BEFORE REAL FLIGHT 請嚴格執行飛行前檢查義務

- Before flying, please check to make sure no one else is operating on the same frequency for the safety.
- Before flight, please check if the batteries of transmitter and receiver are enough for the flight.
- Before turn on the transmitter, please check if the throttle stick is in the lowest position. IDLE switch is OFF.
- When turn off the unit, please follow the power on/off procedure. Power ON- Please turn on the transmitter first, and then turn on receiver. Power OFF- Please turn off the receiver first and then turn off the transmitter. Improper procedure may cause out of control, so please to have this correct habit.
- Before operation, check every movement is smooth and directions are correct. Carefully inspect servos for interference and broken gear.
- Check for missing or loose screws and nuts. See if there is any cracked and incomplete assembly of parts. Carefully check main rotor blades and rotor holders. Broken and premature failures of parts possibly cause resulting in a dangerous situation.
- Check all ball links to avoid excess play and replace as needed. Failure to do so will result in poor flight stability.
- Check the battery and power plug are fastened. Vibration and violent flight may cause the plug loose and result out of control.

- 每次飛行前應先確認所使用的頻率是否會干擾他人，以確保您自身與他人的安全。
- 每次飛行前確定您發射器與接收器電池的電量是在足夠飛行的狀態。
- 開機前確認油門搖桿是否位於最低點，熄火降落開關，定速開關 (IDLE) 是否於關閉位置。
- 開機時必須遵守電源開關機的程序，開機時應先開啟發射器後，再開啟接收器電源；關機時應先關閉接收器後，再關閉發射器電源。不正確的開關程序可能會造成失控的現象，影響自身與他人的安全，請養成正確的操作習慣。
- 開機請先確定直昇機各個動作是否順暢，及方向是否正確，並檢查伺服器的動作是否有干涉或崩齒的情形，使用故障的伺服器將導致不可預期的危險。
- 飛行前確認沒有缺少或鬆脫的螺絲與螺帽，確認沒有組裝不完整或損壞的零件，仔細檢查主旋翼是否有損壞，特別是接近主旋翼夾座的部位。損壞或組裝不完整的零件不僅影響飛行，更會造成不可預期的危險。注意：對損耗、有裂痕零件更新及定期保養檢查的重要性。
- 檢查所有的連桿頭是否有鬆脫的情形，過鬆的連桿頭應先更新，否則將造成直昇機無法操控的危險。
- 確認電池及電源接頭是否固定牢靠，飛行中的震動或激烈的飛行，可能造成電源接頭鬆脫而造成失控的危險。

STANDARD EQUIPMENT 標準配備

 450HC6	 450HH17	 450HB22	 450HB21	 450HB19
 450HT19	 450HT20	 450HG1	 450HZ25	 M3x3 Set Screw x1 M3 止洩螺絲 x1 Motor Pinion Helical Gear 11T x 1 馬達斜齒輪 11T x 1
 460MX (1800KV) Brushless motor x 1 460MX (1800KV) 無刷馬達 x 1	 RCE-BL45X Brushless ESC x 1 RCE-BL45X 無刷定速調速器 x 1	 DS430M Digital Servo x 3 DS430M 數位伺服器 x 3 DS525M Digital Servo x 1 DS525M 數位伺服器 x 1	 3GX Flybarless System 3GX 無平衡翼系統	 360 Carbon fiber blade x 1 360 碳纖維旋翼 x 1

When you see the marks as below, please use glue or grease to ensure flying safety.

標有以下符號之組裝步驟，請配合上膠或上油，以確保使用之可靠度。

- CA:** Apply CA Glue to fix.
R48: Apply Anaerobics Retainer to fix.
T22: Apply Thread Lock to fix.
OIL: Add Grease.

- CA: 使用瞬間膠固定
 R48: 使用金屬管狀固定缺氣膠固定
 T22: 使用螺絲膠
 OIL: 添加潤滑油

When assembling ball links, make sure the "A" character faces outside.

各項塑膠製連桿頭扣接時，A字請朝外。

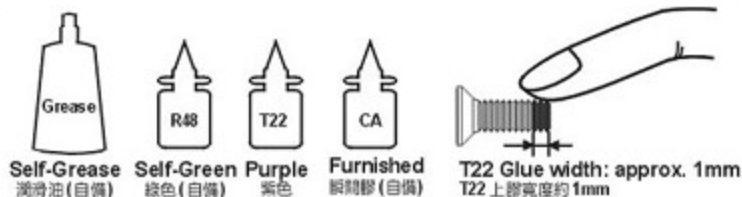

R48 metal tubular adhesive (eg. Bearings). T22 thread lock, apply a small amount on screws or metal parts and wipe surplus off. When disassembling, recommend to heat the metal joint about 15 Seconds. (NOTE: Keep plastic parts away from heat.)

R48 為強力金屬管狀 (如軸承) 接著劑，T22 為螺絲膠，膠合螺絲或金屬內外徑請務必少量使用，必要時請用手去除多餘膠量，欲拆卸時可於金屬接合部位熱烤約 15 秒。(注意！塑膠件避免接近熱源)

450HH17

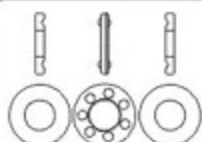

Thrust bearing
止推軸承 (φ 4x φ 8x3.3mm) x 2



Washer
華司 (φ 4x φ 6.5x0.4mm) x 2



Bearing
軸承 (φ 4x φ 8x3mm) x 4

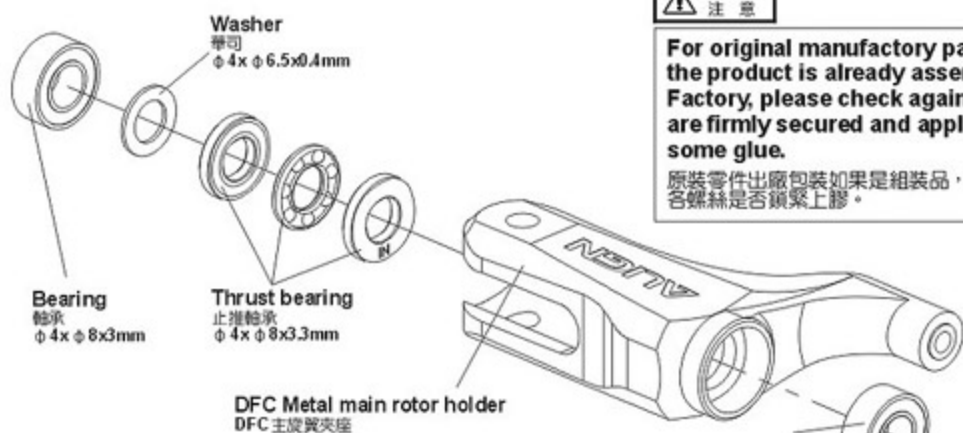

Apply a little amount of T22 thread lock when fixing a metal part.
螺絲鎖附於金屬件請使用適量T22(螺絲膠)

CAUTION
注意

For original manufactory package, if the product is already assembled by Factory, please check again if screws are firmly secured and applied with some glue.

原裝零件出廠包裝如果是組裝品，請需再確認各螺絲是否鎖緊上膠。

CAUTION
注意

Thrust bearing and washer for radial bearing are wear items, and thus should be inspected for replacement after every 20 flights. For flights with high headspeed, the inspection interval should be reduced to ensure flight safety.

止推軸承及橫軸墊圈屬於飛行消耗品，建議每20趟定期檢查及更換，高主旋翼轉速飛行時，請縮短定期檢查之趟數，以確保飛行安全。

CAUTION
注意

Metal main rotor holder
金屬主旋翼夾座

Apply grease on thrust bearing.
止推軸承塗上潤滑油



"IN" mark faces inside

IN 字樣朝內

Thin (larger ID)
(內徑較大)

Thick (smaller ID)
(內徑較小)

Thrust bearing 止推軸承

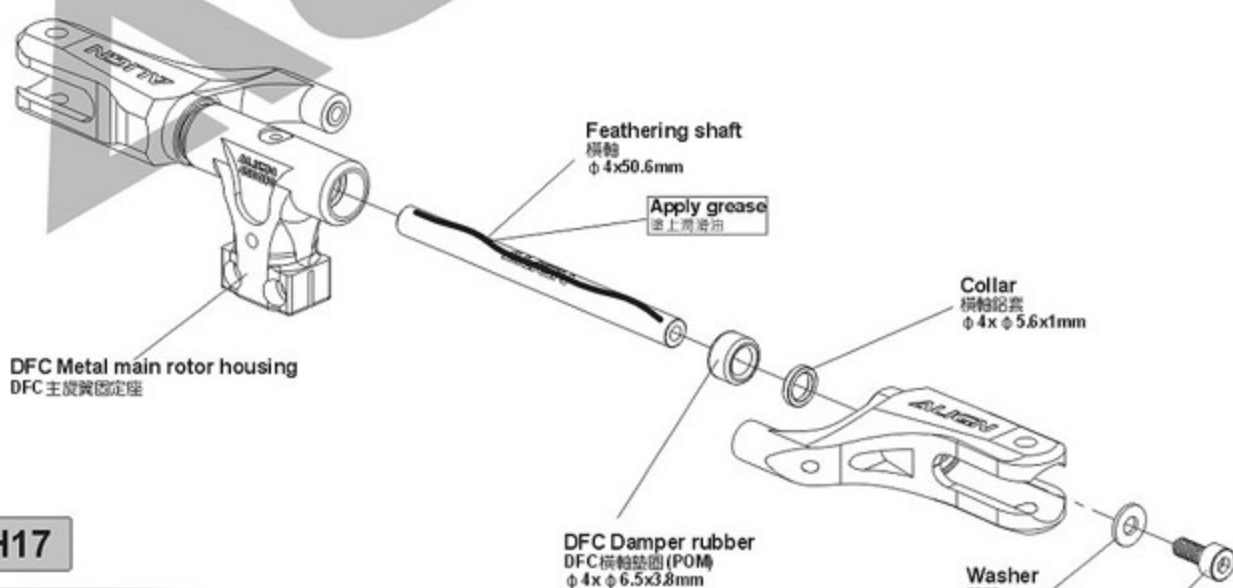

450HH17



Socket screw
圓頭內六角螺絲 (M2.5x6mm) x 2



DFC Damper rubber
DFC 橫軸墊圈 (POM)
(φ 4x φ 6.5x3.8mm) x 2



Washer
華司 (φ 2.6x φ 5.8x0.6mm) x 2



Collar
橫軸銘套 (φ 4x φ 5.6x1mm) x 2

Washer
華司
φ 2.6x φ 5.8x0.6mm

Socket screw
圓頭內六角螺絲
M2.5x6mm

450HH17

Linkage ball A(M2x2.5)
球頭A(M2x2.5)(ϕ 4.75x7.18mm) x 2

Linkage ball G(M2x2.5)
球頭G(M2x2.5)(ϕ 4.75x11.18mm) x 2

Long linkage ball(M2x2.5)
導板長球頭(M2x2.5)(ϕ 4.75x23.68mm) x 1

DFC CCPM Swashplate
DFC CCPM 十字盤組

Linkage ball A(M2x2.5)
球頭A(M2x2.5)(ϕ 4.75x7.18mm)

Linkage ball G(M2x2.5)
球頭G(M2x2.5)(ϕ 4.75x11.18mm)

Long linkage ball(M2x2.5)
導板長球頭(M2x2.5) ϕ 4.75x23.68mm

Apply a little amount of T22 thread lock when fixing a metal part.
螺絲鎖附於金屬件請使用適量T22(螺絲膠)

CAUTION
注意

For original manufactory package, if the product is already assembled by Factory, please check again if screws are firmly secured and applied with some glue.

原裝零件出廠包裝如果是組裝品，請需再確認各螺絲是否鎖緊上膠。

450HH17

DFC linkage bearing sleeve
DFC 連桿軸承套 (ϕ 2x ϕ 3x ϕ 4.5mm) x 2

Bearing
軸承 (ϕ 2x ϕ 4.5x2mm) x 4

Socket screw
圓頭內六角螺絲(M2x6mm) x 2

DFC Linkage rod(A)
DFC 連桿A (M1.6x12mm) x 2

DFC Ball Link
DFC 連桿頭 x 2

Socket collar screw
圓頭內六角軸套螺絲(M2x15mm) x 2

Washer
華司(ϕ 2x ϕ 3.6x0.2mm) x 2

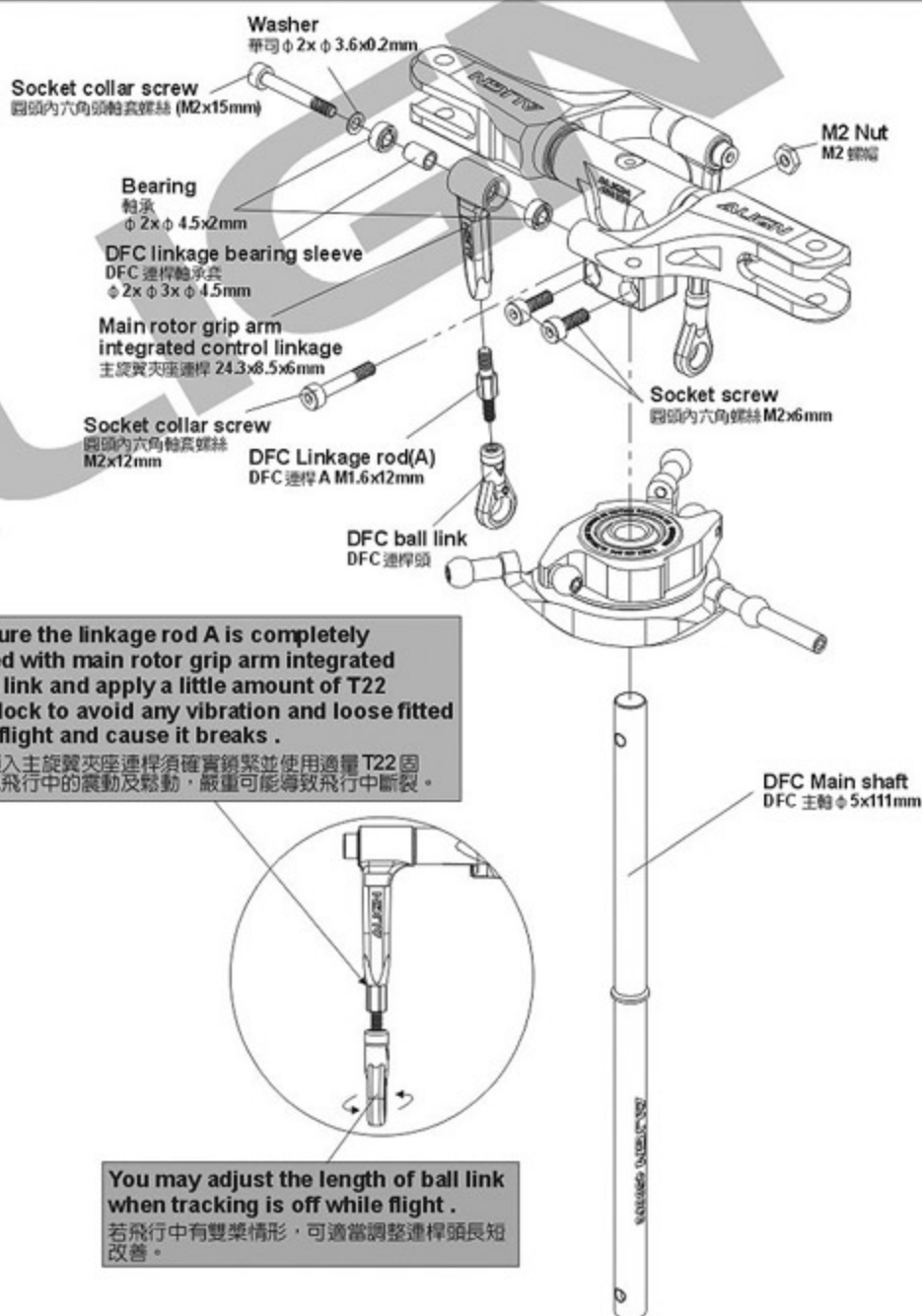

450HB19

Socket collar screw
圓頭內六角軸套螺絲(M2x12mm) x 1

M2 Nut
M2 螺帽 x 1

450HB22



Bearing
軸承 (φ 5xφ 11x5mm) x2



Socket screw
圓頭內六角螺絲 (M2.5x6mm) x4



Socket button head screw
半圓頭內六角螺絲 (M2.5x5mm) x8

Bearing
軸承
φ 5xφ 11x5mm

450L Metal bearing holder
450L 金屬主軸固定座

450L Gyro mount
450L 陀螺儀固定座

Socket button head screw
半圓頭內六角螺絲 M2.5x5mm

450L Frame Mounting Bolt
450L 機身銘柱
φ 4x33mm

3GX foam tape
3GX 泡棉

3GX flyerless system (Position #1)
3GX 飛平翼系統 (位置1)

Directional Arrow
方向指示

While you stick 3GX on the bottom plate, please make sure the control panel is aimed at suitable position.

黏貼 3GX 時請比對底板孔位，調整至適當位置。

450L Shapely Reinforcement brace (L)
450L 機身增強片 (左)

Socket screw
圓頭內六角螺絲 M2.5x6mm

450L main frame(L)
450L 板羅架板 1.2mm (左)

Apply a little amount of T22 thread lock when fixing a metal part.
螺絲鎖附於金屬件請使用適量 T22 (螺絲膠)



For original manufactory package, if the product is already assembled by Factory, please check again if screws are firmly secured and applied with some glue.

原裝零件出廠包裝如果是組裝品，請需再確認各螺絲是否鎖緊上膠。



If 3GX was to be mounted inverted (Position #1), please enter connect anti-torque compensation section and set it as "reverse" (STATUS LED turns red) to avoid the effect of the performance of gyro lock.

選擇 3GX 面板朝下的安裝方式時 (位置 1)，請進入設定選項中的反扭力補償設定，並將反扭力補償設為 "反向" (STATUS 燈為紅燈)，以免影響陀螺儀鎖定效果。



450HB22A



Washer
華司 (φ 2.6xφ 5.8x0.6mm) x3

450HB22



Socket button head screw
半圓頭內六角螺絲 (M2.5x5mm) x1



Socket button head screw
半圓頭內六角螺絲 (M2.5x10mm) x2

Skid mount
腳架固定座

Bottom plate
底板

Washer
華司
φ 2.6xφ 5.8x0.6mm

Landing Skid
450PRO 腳架

Socket button head screw
半圓頭內六角螺絲
M2.5x5mm

Socket button head screw
半圓頭內六角螺絲
M2.5x10mm



Main frame assembly key point :

First do not fully tighten the screws of main frames and put two bearings through the main shaft to check if the movements are smooth. The bottom bracket must be firmly touched the level table top(glass surface) ; please keep the smooth movements on main shaft and level bottom bracket, then slowly tighten the screws. This assembly can help for the power and flight performance.

機身側板組立重點：

側板螺絲先不完全鎖緊，放入主軸貫穿二顆軸承確認上下移動必需滑順，主體底板必須與水平桌面(玻璃平面)踏實緊貼；請保持主軸滑順與底板平行桌面後慢慢鎖緊螺絲。正確側板的組裝對動力與飛行性能有顯著幫助。

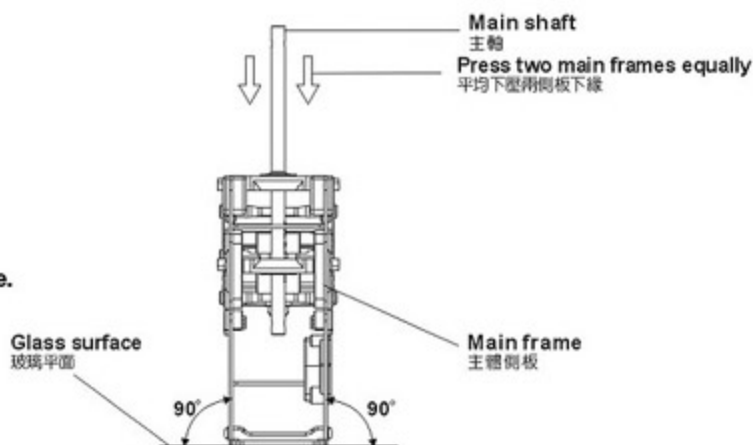

Apply a little amount of T22 thread lock when fixing a metal part.
螺絲鎖附於金屬件請使用適量 T22(螺絲膠)



For original manufactory package, if the product is already assembled by Factory, please check again if screws are firmly secured and applied with some glue.

原裝零件出廠包裝如果是組裝品，請需再確認各螺絲是否鎖緊上膠。

Recommend sanding the marked position with a waterproof abrasive paper (#800-1000) as below illustration to avoid the wires of electric parts to be cut.

建議於下圖色塊標示處，可使用#800~1000水砂紙打磨，可防止電子設備電線被割破。

Waterproof abrasive paper
水砂紙

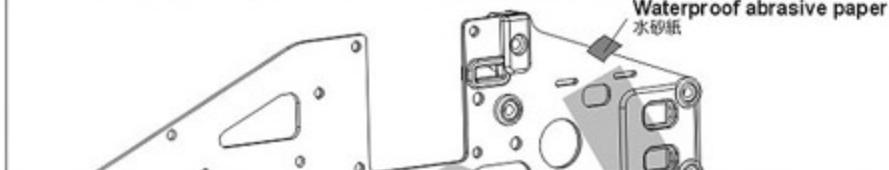

450HB22A



Socket button head self tapping screw
半圓頭內六角自攻螺絲
(T2.6x6mm) x 4

450HB22



Socket button head screw
半圓頭內六角螺絲(M2.5x5mm) x 4

Battery latch lever
電池扣拉桿

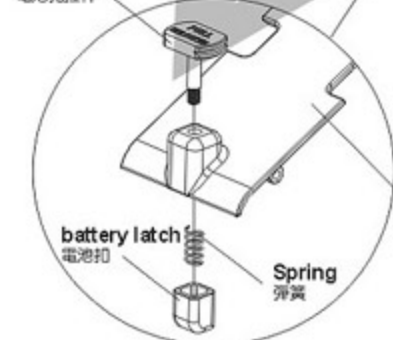

Battery release latch installation illustration
電池扣安裝示意圖

450L Brushless ESC mounting plate
450L 調速器座

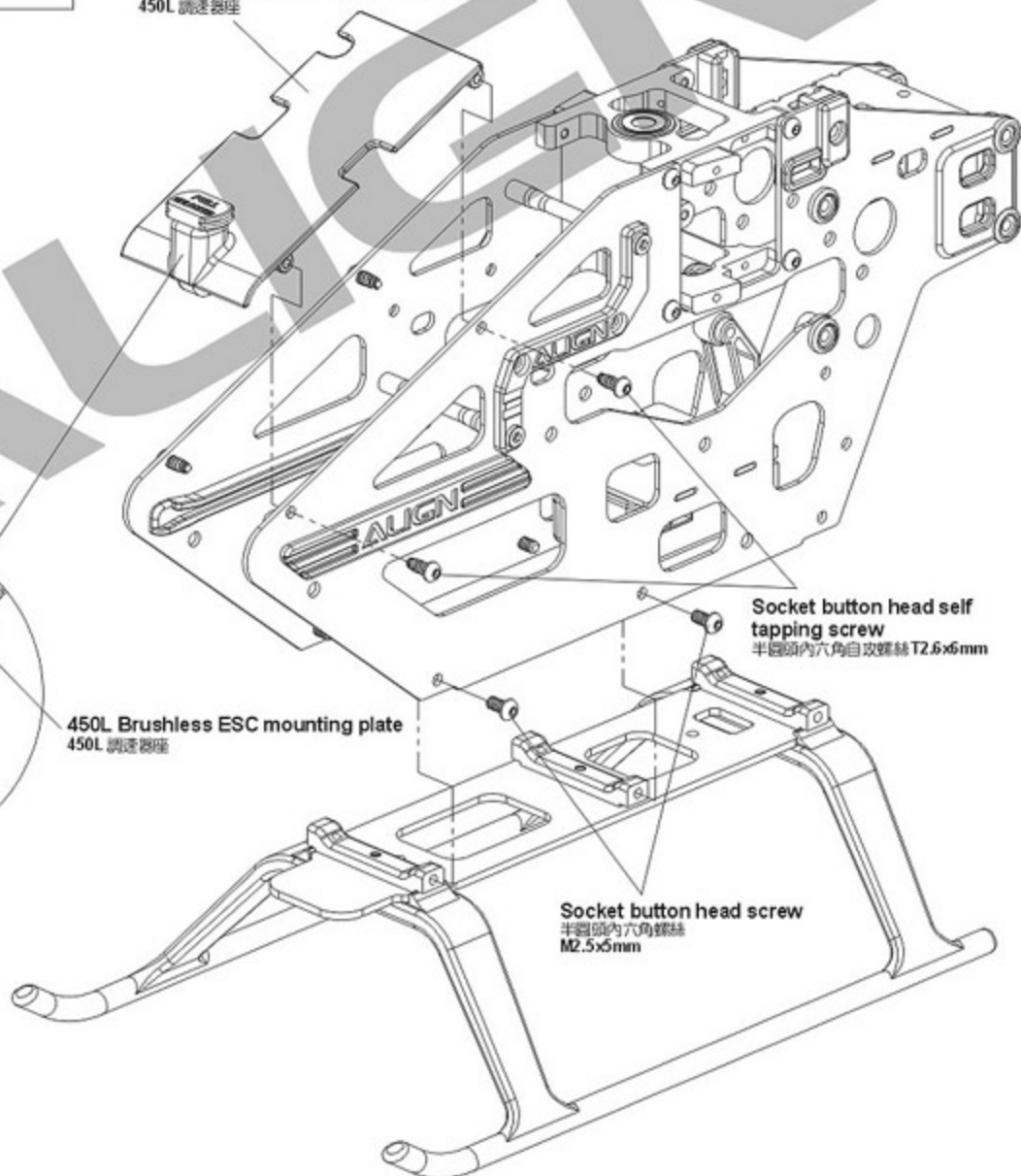

450HZ23



450HZ22



Apply a little amount of T22 thread lock when fixing a metal part.
螺絲鎖附於金屬件請使用適量 T22 (螺絲膠)

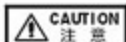

For original manufactory package, if the product is already assembled by Factory, please check again if screws are firmly secured and applied with some glue.

原裝零件出廠包裝如果是組裝品，請再確認各螺絲是否鎖緊上膠。

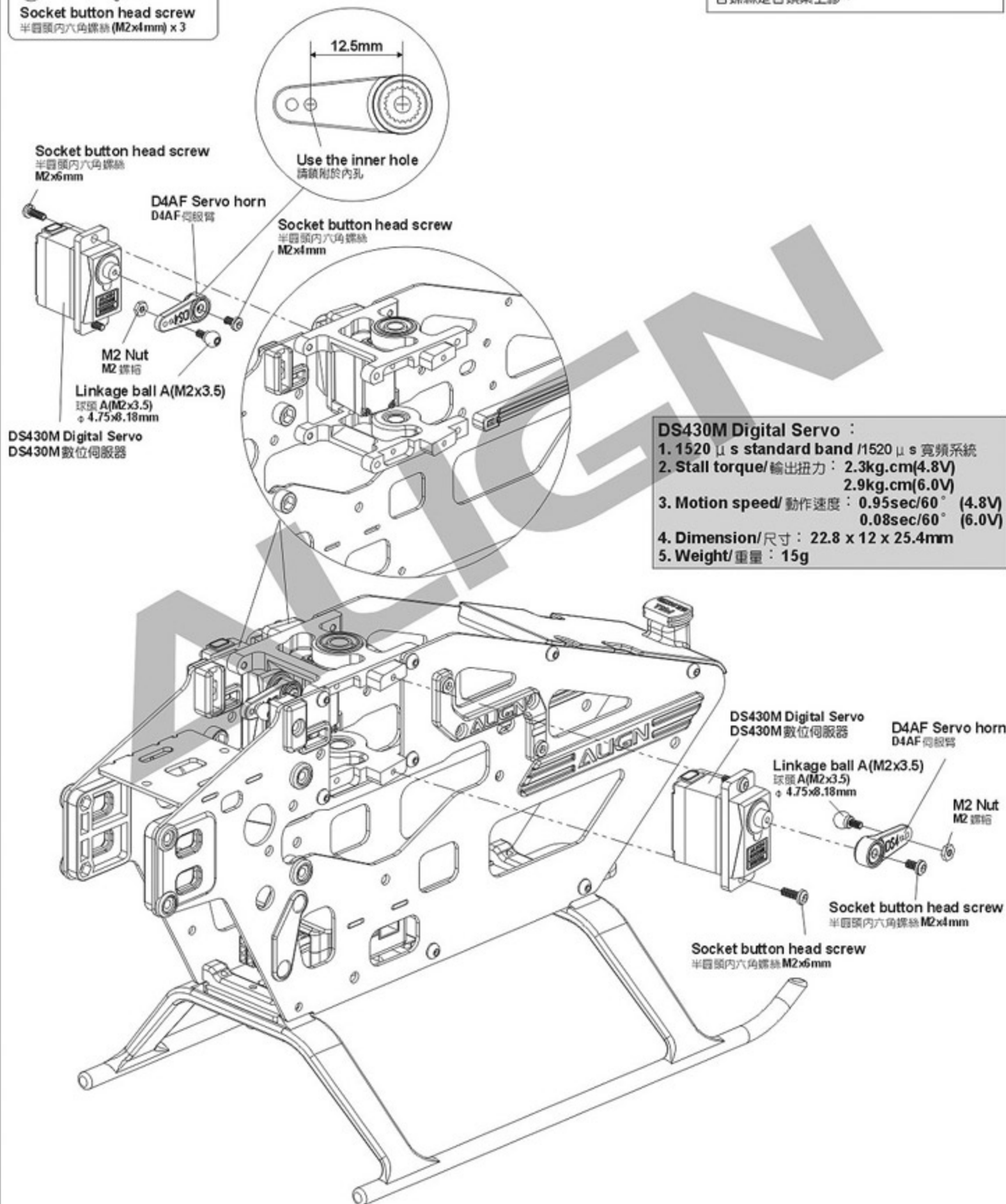

450HB22



Socket screw

圓頭內六角螺絲 (M2.5x6mm) x 4

Apply a little amount of T22 thread lock when fixing a metal part.
螺絲鎖附於金屬件請使用適量 T22(螺絲膠)



注意

For original manufactory package, if the product is already assembled by Factory, please check again if screws are firmly secured and applied with some glue.

原裝零件出廠包裝如果是組裝品，請需再確認各螺絲是否鎖緊上膠。

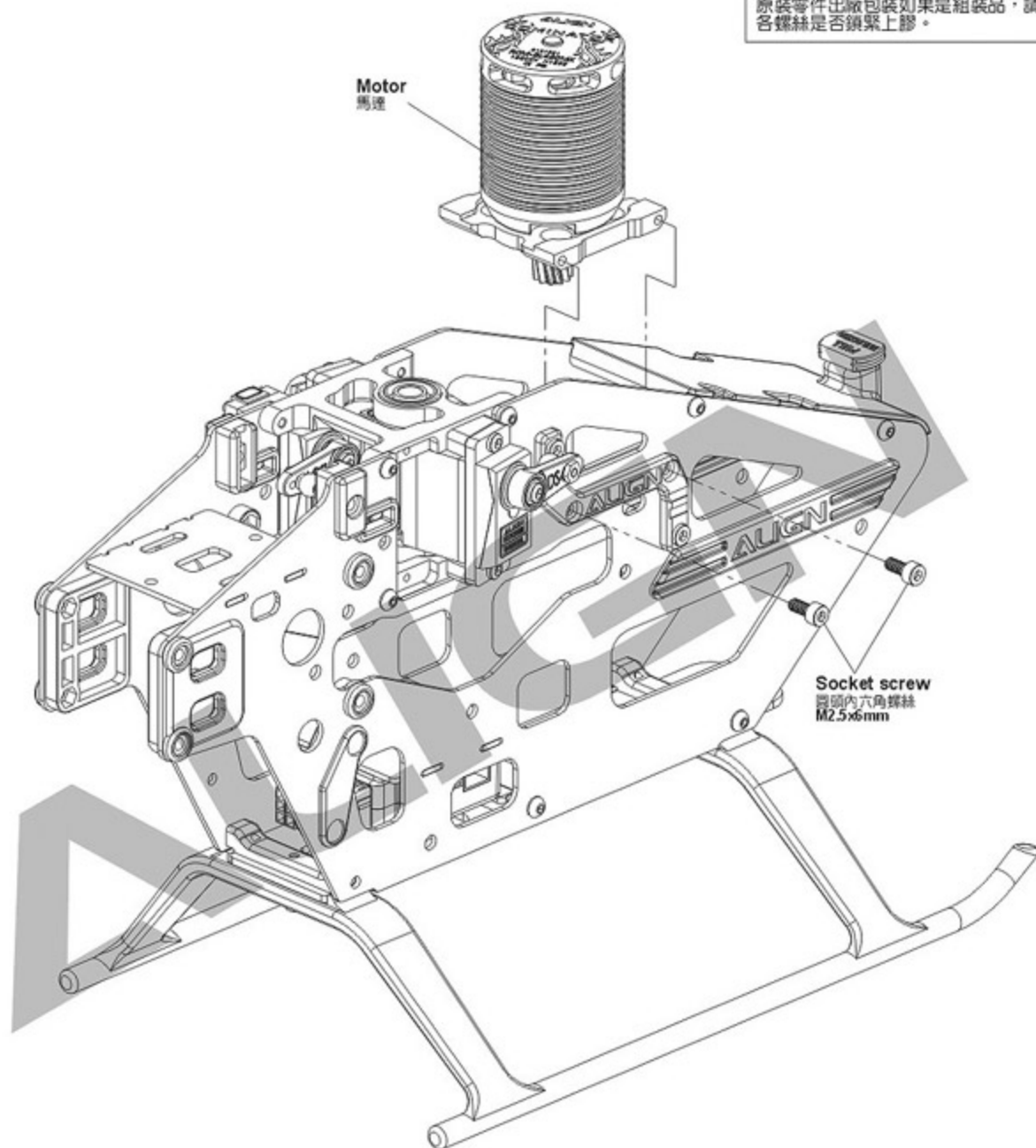

450HB22A



Socket screw

圓頭內六角螺絲 (M2.5x6mm) x 2



Washer

華司
(ϕ 2.6 x ϕ 5.8x0.6mm) x 2

450HZ23



M3 Set screw

M3 止洩螺絲 (M3x3mm) x 1

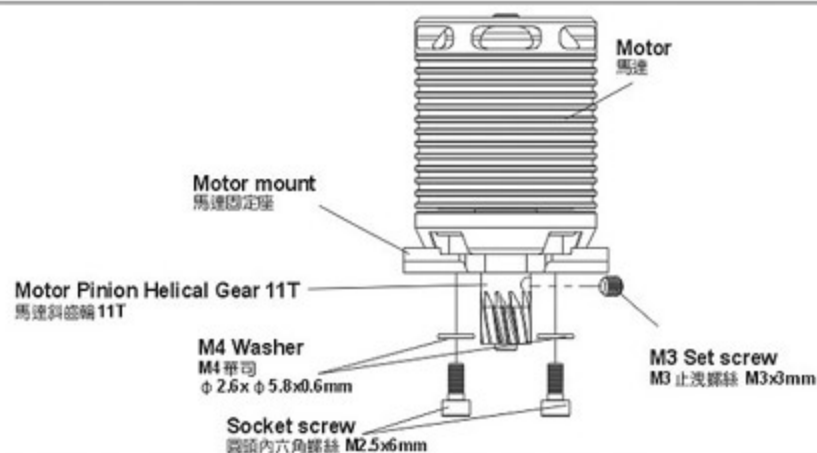

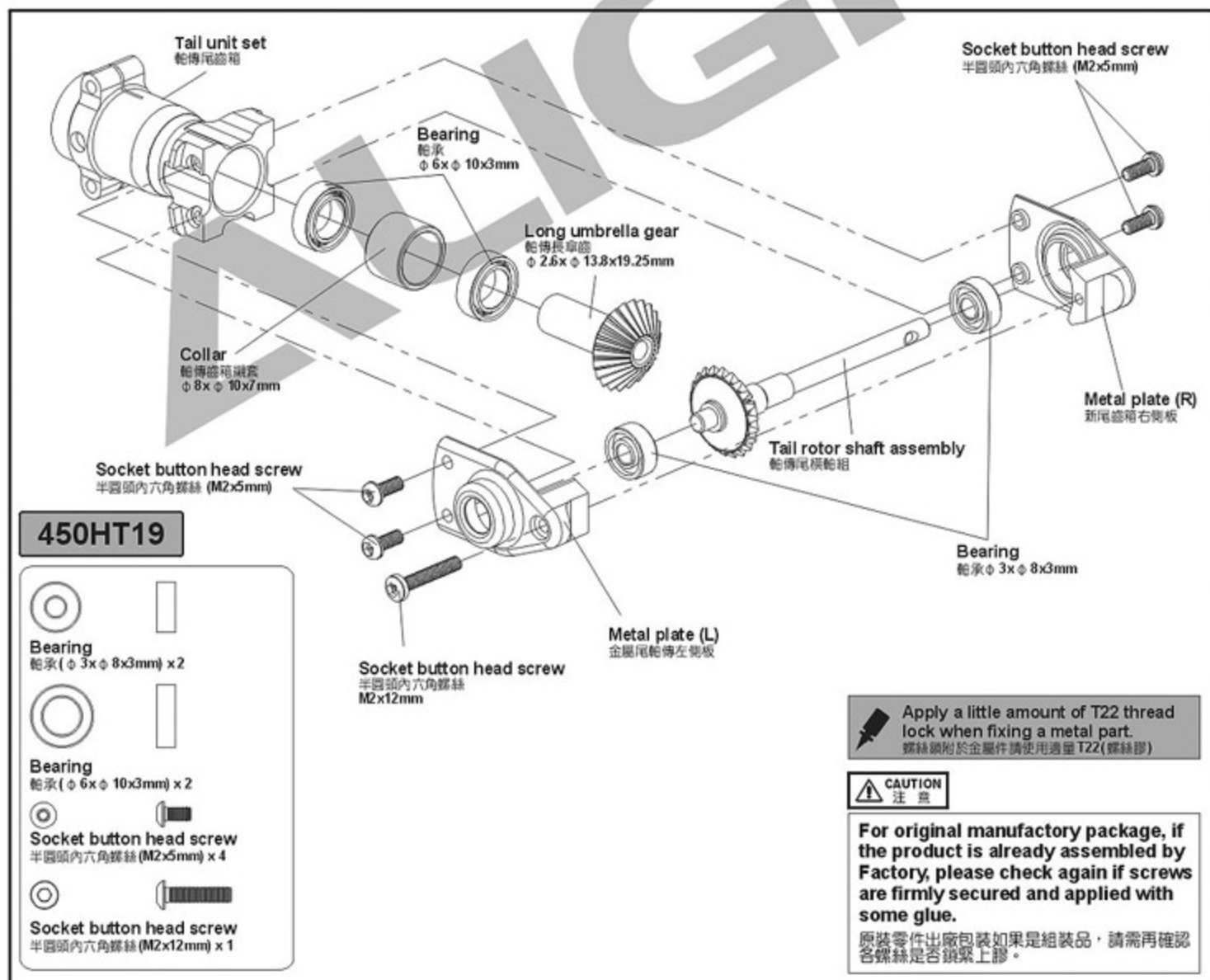
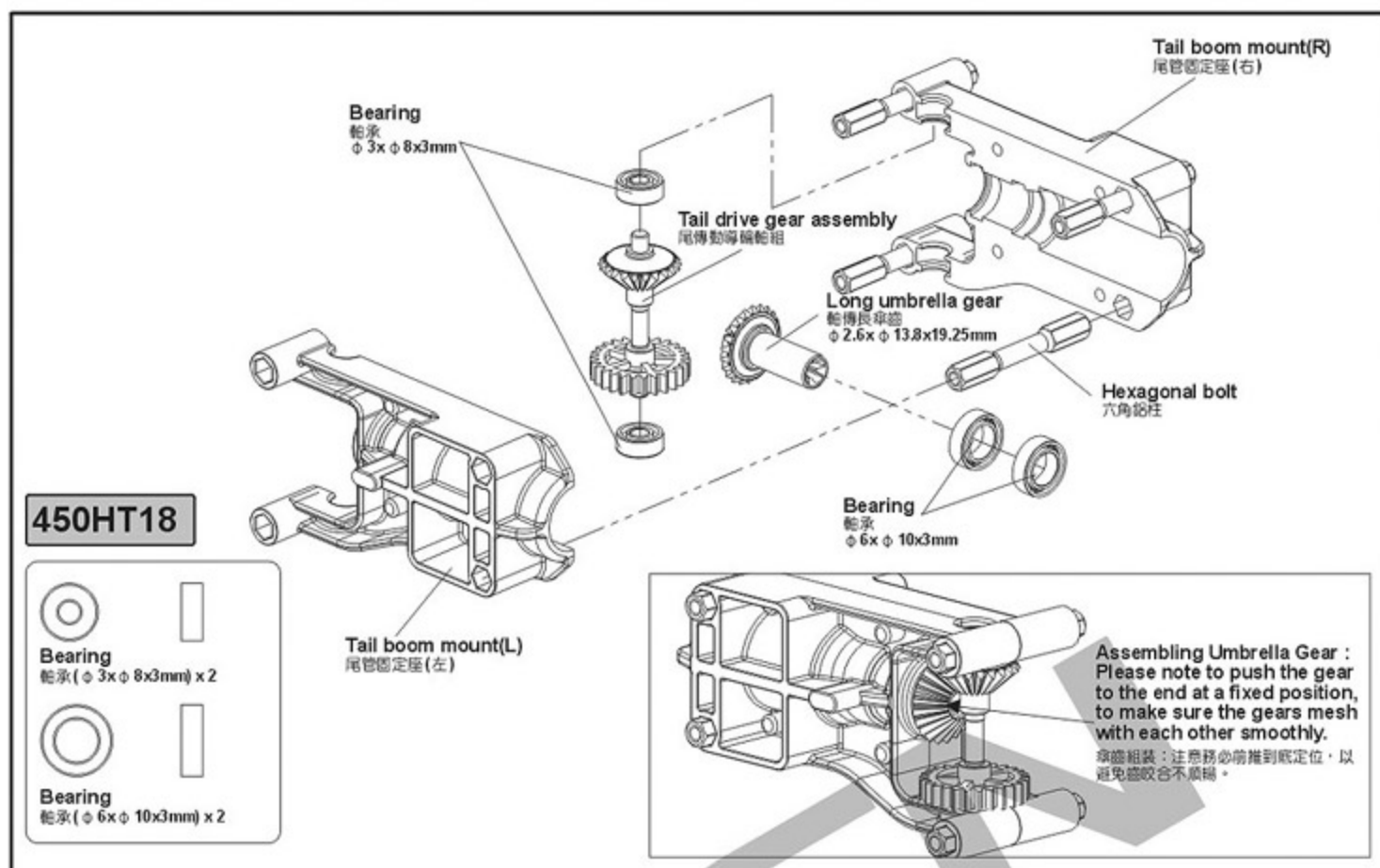

Already assembled by factory, please note to check again.
已組裝完成，請務必自行再確認。

When assembling into the tail boom, please apply some oil on the surface, to make it smooth during the assembling and keep it vertical with the torque tube for smooth rotation.
插入尾管內時，外表抹些潤滑油，以確保平滑壓入尾管中並與尾傳動軸保持垂直，讓尾輪傳動順暢。

Apply a little amount of T22 thread lock when fixing a metal part.
螺絲鎖附於金屬件請使用適量T22(螺絲膠)

CAUTION 注意

For original manufactory package, if the product is already assembled by Factory, please check again if screws are firmly secured and applied with some glue.
原裝零件出廠包裝如果是組裝品，請需再確認各螺絲是否鎖緊上膠。

When assembling the tail boom, please aim at the fixing hole $\phi 3$.
裝入尾管時請注意孔對準尾管 $\phi 3$ 固定孔

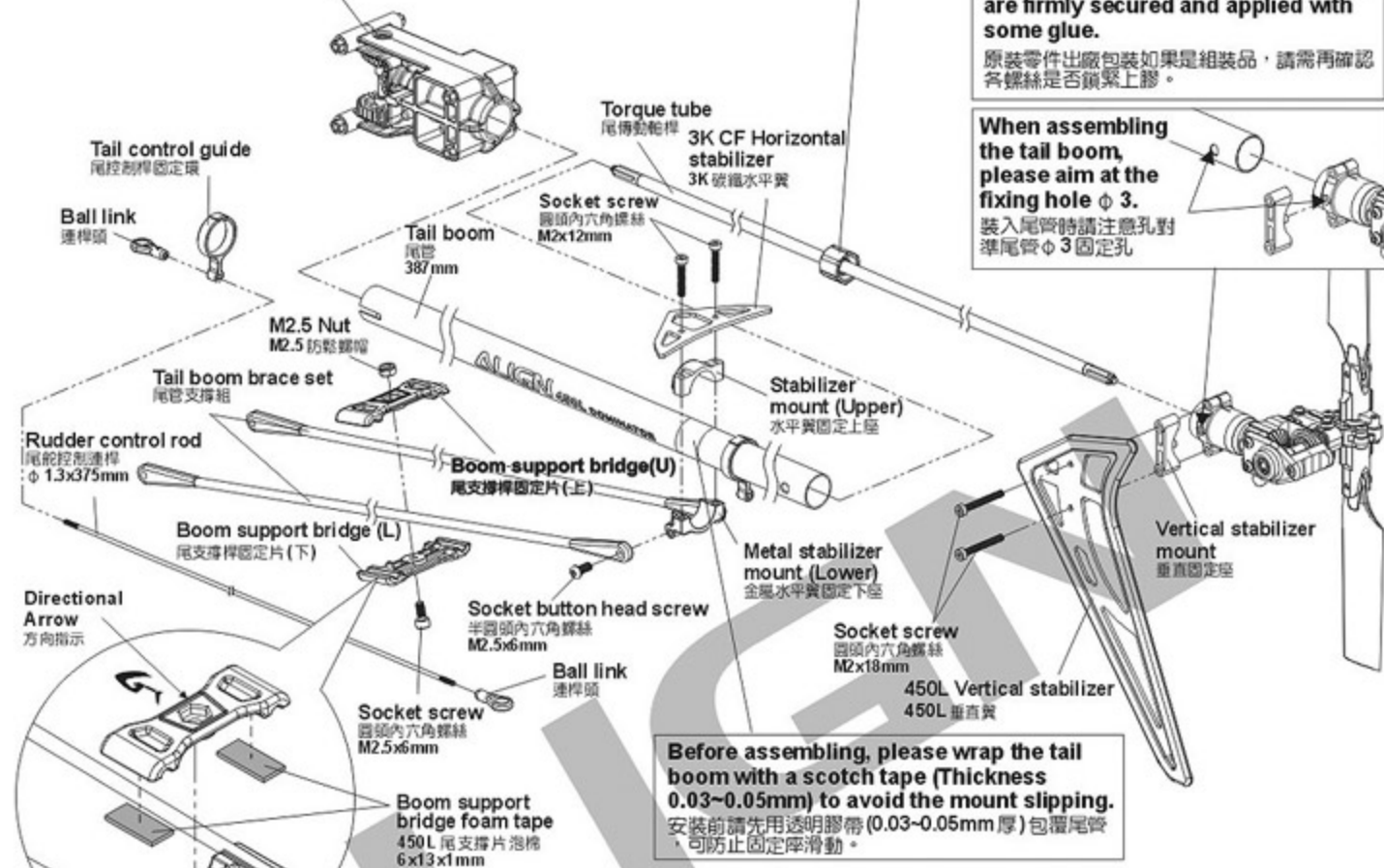

Before assembling, please wrap the tail boom with a scotch tape (Thickness 0.03~0.05mm) to avoid the mount slipping.
安裝前請先用透明膠帶(0.03~0.05mm厚)包覆尾管，可防止固定座滑動。

TIP TO FIX THE TORQUE TUBE 傳動軸軸承固定位要領

Please apply some CA glue to fix bearing on the torque tube, avoid CA glue from the dust or may cause the bearing stuck. When assembling into the tail boom, please apply some oil and use the attached torque tube mount helper to press the bearing holder of the torque tube into the tail boom horizontally.
請以少量CA將軸承固定於尾傳動軸上，避免CA沾到軸承的防塵蓋而導致軸承卡死，插入尾管內時，尾傳動軸承墊圈外表抹些潤滑油，利用隨附軸承安裝套將尾傳動軸承墊圈平行壓入尾管中不可歪斜。

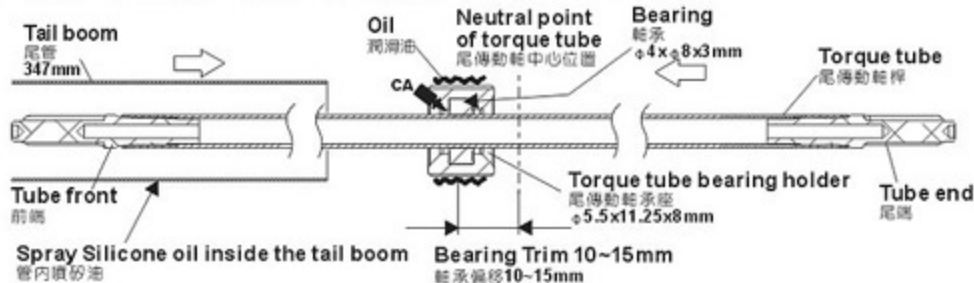

CAUTION 注意

The wider side of trapezoid shape imprinted on support bridge need to face forward.
尾支撐桿固定片上，梯形圖示較寬底邊請朝向機頭。

Boom support bridge foam tapes need to be attached to the slots in top and bottom of 450L boom support bridge.
450L 尾支撐桿固定片上下凹槽，需黏貼450L 尾支撐片泡棉。

450HT20

- Socket screw**
圓頭內六角螺絲 (M2.5x6mm) x 4
- M2.5 Nut**
M2.5 防鬆螺帽 x 1
- Ball Link**
連桿頭 x 2
- Boom support bridge foam tape**
450L 尾支撐片泡棉 (6x13x1mm) x 4

450HT19

- Socket screw**
圓頭內六角螺絲 (M2x12mm) x 2
- Socket screw**
圓頭內六角螺絲 (M2x18mm) x 2
- Socket button head screw**
半圓頭內六角螺絲 (M2.5x6mm) x 2

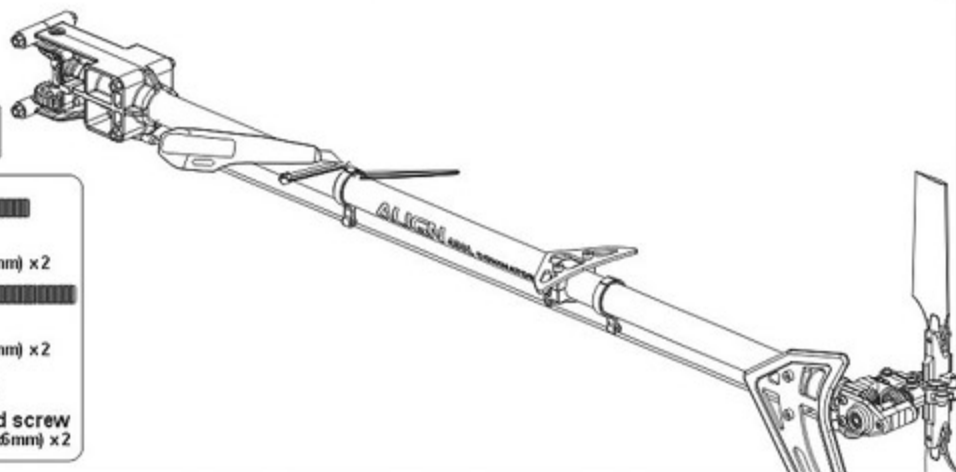

450HB22



Canopy mounting bolt
機頭罩固定柱 (2.5x21.5mm) x2

450HT18



Socket button head screw
半圓頭內六角螺絲 (M2.5x8mm) x8



CAUTION 注意
For original manufactory package, if the product is already assembled by Factory, please check again if screws are firmly secured and applied with some glue.
原裝零件出廠包裝如果是組裝品，請需再確認各螺絲是否鎖緊上膠。

450HB22A



M2.5 Set screw
M2.5止波螺絲 (M2.5x12mm) x2

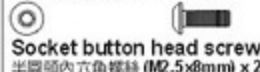

Socket button head screw
半圓頭內六角螺絲 (M2.5x8mm) x2



Socket button head self tapping screw
半圓頭內六角自攻螺絲 (T2.6x6mm) x2

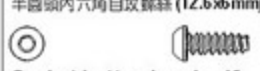

Socket button head self tapping screw
半圓頭內六角自攻螺絲 (T2.6x8mm) x2

Apply a little amount of T22 thread lock when fixing a metal part.
螺絲鎖附於金屬件請使用適量T22(螺絲膠)

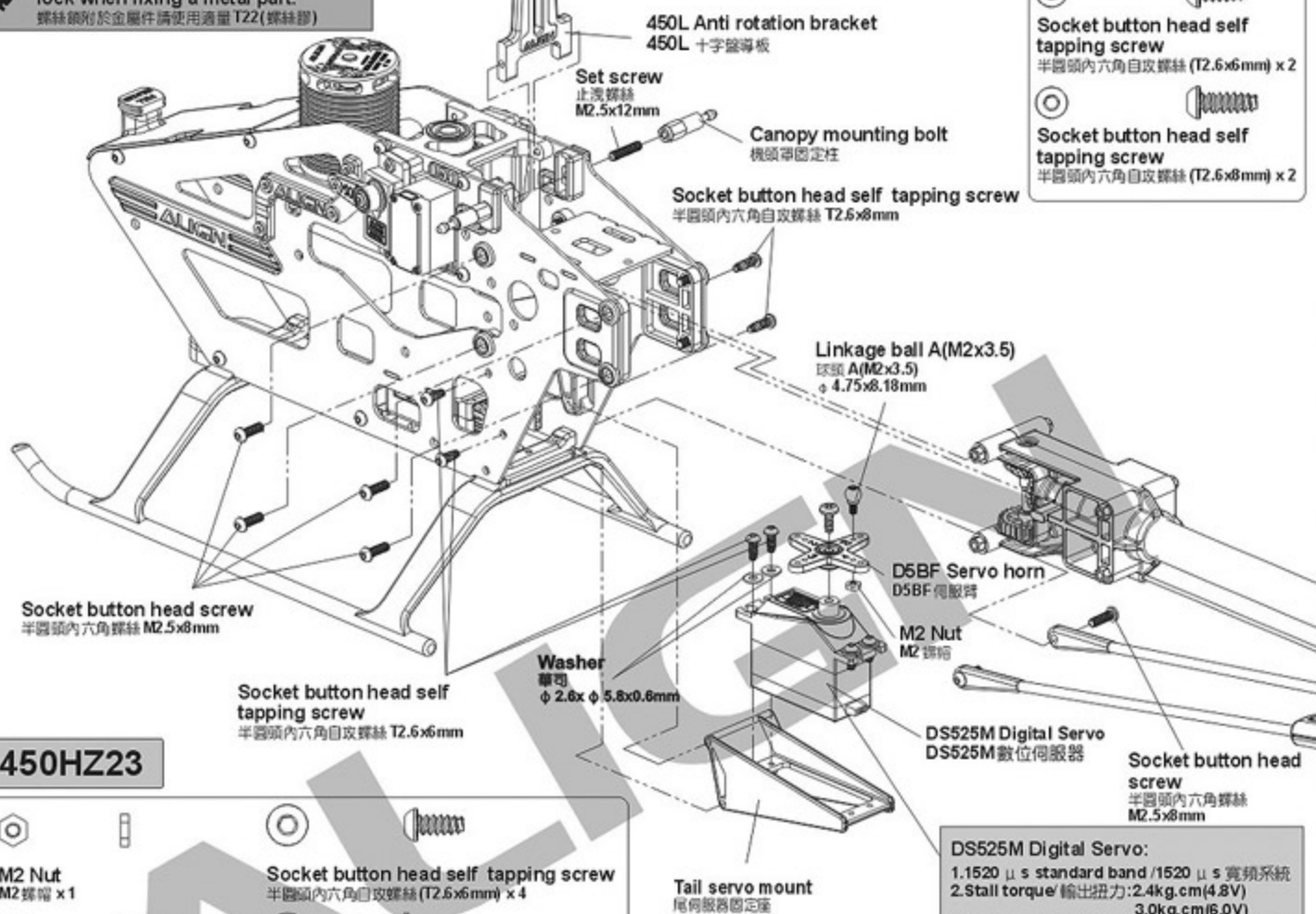

450L Anti rotation bracket
450L 十字盤導板

Set screw
止波螺絲
M2.5x12mm

Canopy mounting bolt
機頭罩固定柱

Socket button head self tapping screw
半圓頭內六角自攻螺絲 T2.6x8mm

Linkage ball A(M2x3.5)
球頭 A(M2x3.5)
φ 4.75x8.18mm

D5BF Servo horn
D5BF 伺服臂

M2 Nut
M2 螺帽

DS525M Digital Servo
DS525M 數位伺服器

Socket button head screw
半圓頭內六角螺絲
M2.5x8mm

Socket button head screw
半圓頭內六角螺絲 M2.5x8mm

Socket button head self tapping screw
半圓頭內六角自攻螺絲 T2.6x6mm

Washer
華司
φ 2.6x φ 5.8x0.6mm

Tail servo mount
尾伺服器固定座

450HZ23



M2 Nut
M2 螺帽 x1



Socket button head self tapping screw
半圓頭內六角自攻螺絲 (T2.6x6mm) x4



Linkage ball A(M2x3.5)
球頭 A(M2x3.5) (φ 4.75x8.18mm) x1



Washer
華司 (φ 2.6x φ 5.8x0.6mm) x4

DS525M Digital Servo:
1. 1520 μs standard band / 1520 μs 寬頻系統
2. Stall torque/ 輸出扭力: 2.4kg.cm(4.8V)
3.0kg.cm(6.0V)
3. Motion speed/ 動作速度: 0.08sec/60° (4.8V)
0.06sec/60° (6.0V)
4. Dimension/ 尺寸: 35.1 x 15.1 x 29mm
5. Weight/ 重量: 29g

Cross screw
圓頭十字螺絲
M2x4mm

Main gear case
主齒中心座
φ 10x φ 21.5x7.8mm

Slant thread main drive gear 121T
斜主齒輪 121T

One-way Shaft ring
單向軸套圈
φ 6x φ 8x1.6mm

One-way bearing
單向軸承
φ 6x φ 10x12mm
Already assembled
已裝入

OIL
潤滑油

Autoration tail drive gear
尾驅動主齒 106T

450HB19



Cross screw
圓頭十字螺絲 (M2x4mm) x4



Shaft ring
單向軸套圈 (φ 6x φ 8x1.6mm) x1

Character side faces down
六角刻字面朝下

One-way bearing shaft
單向軸承套
φ 5x φ 6x21.5mm

450HH17

Main Blade Fixing Screw 鎖主旋翼用螺絲



Socket collar screw
圓頭內六角軸套螺絲 (M3x16mm) x 2



M3 Nut
M3 防鬆螺帽 x 2

When tightening the main blade fixing screw, please tighten it firmly, but not over tighten, or it may cause the damage of main blade holder and result in danger.

鎖緊主旋翼螺絲須注意適當緊度即可，過緊可能導致主旋翼夾座受損，飛行意外發生。

Apply a little amount of T22 thread lock when fixing a metal part.
螺絲鎖劑於金屬件請使用適量 T22 (螺絲膠)



For original manufactory package, if the product is already assembled by Factory, please check again if screws are firmly secured and applied with some glue.

原裝零件出廠包裝如果是組裝品，請再確認各螺絲是否鎖緊上膠。

450HZ24



Main shaft spacer(0.1)
主軸墊片 (0.1)
($\phi 5 \times \phi 9 \times 0.1 \text{mm}$) x 1



Main shaft spacer(0.2)
主軸墊片 (0.2)
($\phi 5 \times \phi 9 \times 0.2 \text{mm}$) x 1

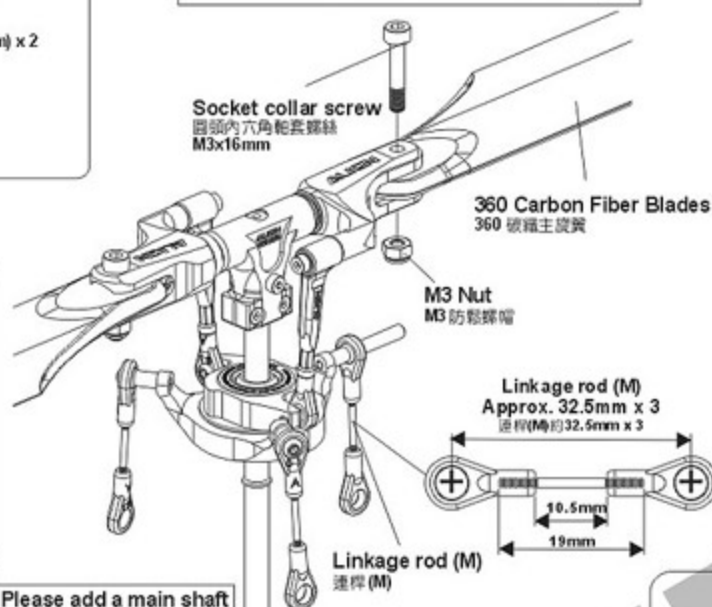

Socket collar screw
圓頭內六角軸套螺絲
M3x16mm

360 Carbon Fiber Blades
360 碳纖維旋翼

M3 Nut
M3 防鬆螺帽

Linkage rod (M)
Approx. 32.5mm x 3
連桿(棒)約 32.5mm x 3

Linkage rod (M)
連桿 (M)

Please add a main shaft spacer if necessary.
依需求加裝主軸墊片
 $\phi 5 \times \phi 9 \times 0.1 \text{mm}$
 $\phi 5 \times \phi 9 \times 0.2 \text{mm}$

450HZ22

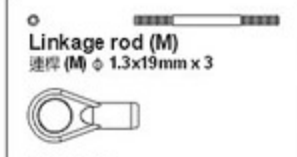

Linkage rod (M)
連桿 (M) $\phi 1.3 \times 19 \text{mm}$ x 3

Ball link
連桿頭 x 6

450HB19



Socket collar screw
圓頭內六角軸套螺絲 (M2x12mm) x 1

M2 Nut
M2 螺帽 x 1

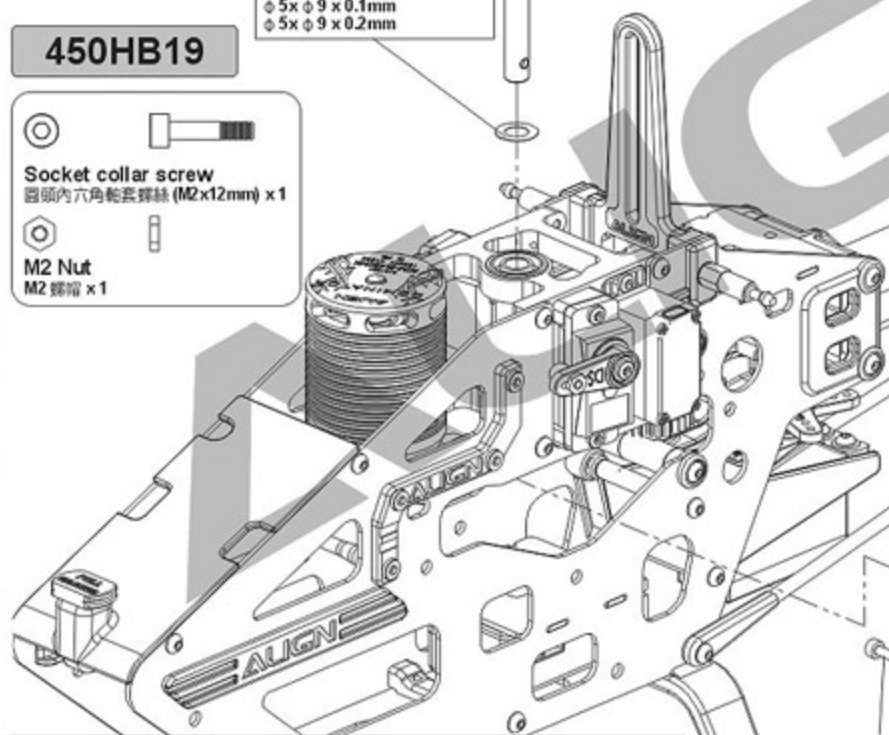

Set the motor pinion gear to main drive gear mesh to approximately 0.1mm to avoid excess power consumption motor burnt due to overload.

馬達前後可移動以保持兩齒輪咬合處約有 0.1mm 間隙，過緊齒咬合將造成動力損失或馬達高阻力的過載，嚴重可能導致馬達燒毀。

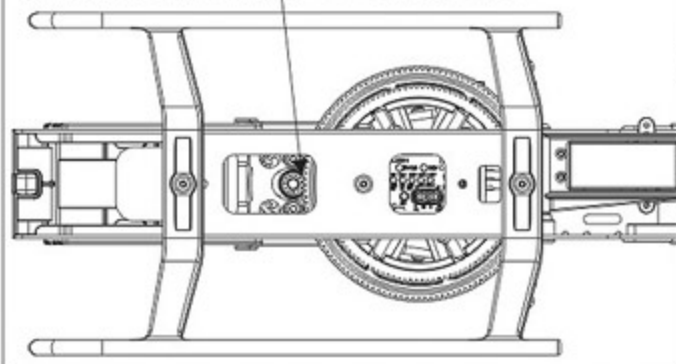

While using 3GX Flybarless system, please use the swashplate leveler to calibrate swashplate. Adjust the length of servo linkage rod to make sure the swashplate is leveled before start setting up 3GX to ensure 3GX provides the best performance.

使用 3GX 無平衡系統，請務必使用十字盤調整器校正十字盤，調整伺服器連桿長度，確保十字盤達到水平狀態，再進行 3GX 基本機體設定，這樣才能確保 3GX 飛行性能達到最佳效果。

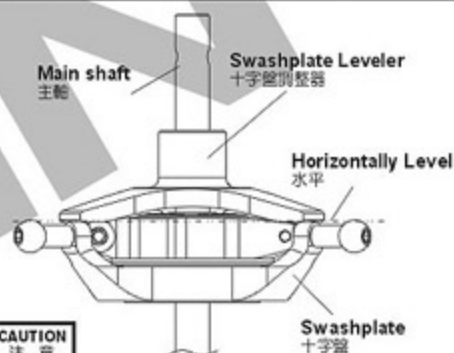

Main shaft
主軸

Swashplate Leveler
十字盤調整器

Horizontally Level
水平

Swashplate
十字盤

Slant thread main drive gear set
斜主齒輪組

Socket collar screw
圓頭內六角軸套螺絲
M2x12mm

Please do not over tighten, a over tighten may cause the autorotation tail drive gear deformed.
請以適當扭力鎖附即可，過度鎖緊易造成尾驅動主齒變形。

M2 Nut
M2 螺帽

The lower edge of main gear need to be lined up with lower edge of pinion gear. This will ensure smooth meshing, and avoid interference between pinion's base and main gear which can lead to unusual wear.

馬達齒下緣必須與主齒輪下緣水平切齊，如此才能確保齒輪傳動順暢，避免馬達主齒輪根部與新式斜主齒輪產生異常干涉磨損。

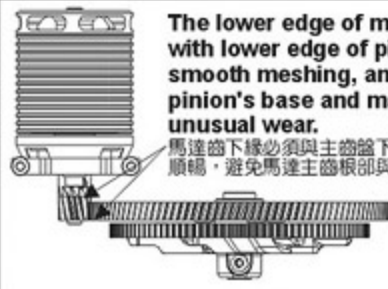



Apply a little amount of T22 thread lock when fixing a metal part.
螺絲鎖附於金屬件請使用適量 T22(螺絲膠)



For original manufactory package, if the product is already assembled by Factory, please check again if screws are firmly secured and applied with some glue.

原裝零件出廠包裝如果是組裝品，請需再確認各螺絲是否鎖緊上膠。

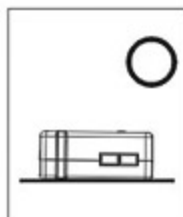

1. Consult the following diagram for 3GX installation direction, with arrow pointing toward nose or tail of helicopter. 3GX needs to be mounted flat on gyro mounting platform, away from vibration sources.

2. Two pieces of foam mounting tape can be used if helicopter experiences vibration induced flight instability. However, if this still doesn't cure the problem, please check the helicopter mechanics and minimize mechanical vibrations, or reduce the headspeed.

3. Please secure with genuine factory issued double sided anti-vibration mounting tape.

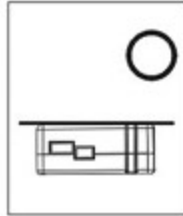

※ If 3GX was to be mounted inverted, please enter connect anti-torque compensation section and set it as "reverse" (STATUS LED turns red); to avoid the effect of the performance of gyro lock.

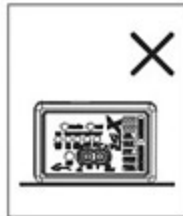

1. 3GX 擺放方向請參照圖示，方向指示箭頭指向機頭或機尾，水平擺放於陀螺儀固定座，並避開震動源。

2. 機體震動會影響陀螺儀偵測，造成飛行不穩定，可於 3GX 下方貼附 2 片泡棉減震，若仍未改善，請檢查機體排除震動或降低主旋翼轉速。

3. 請使用原廠提供避震泡棉雙面膠固定。



※ 選擇 3GX 面板朝下的安裝方式時，請進入設定選項中的反扭力補償設定，並將反扭力補償設為 "反向" (STATUS 燈為紅燈)，以免影響陀螺儀鎖定效果。

Rev. Anti torque compensation
反向 反扭力補償

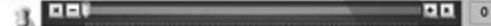

3GX
Directional Arrow
方向指示

3GX Flybarless System
3GX 無平衡翼系統

3GX flybarless system
(Position #2)
3GX 無平衡翼系統 (位置 2)

3GX foam tape
3GX 泡棉

RCE-BL45X Brushless ESC
RCE-BL45X 無刷定速調速器

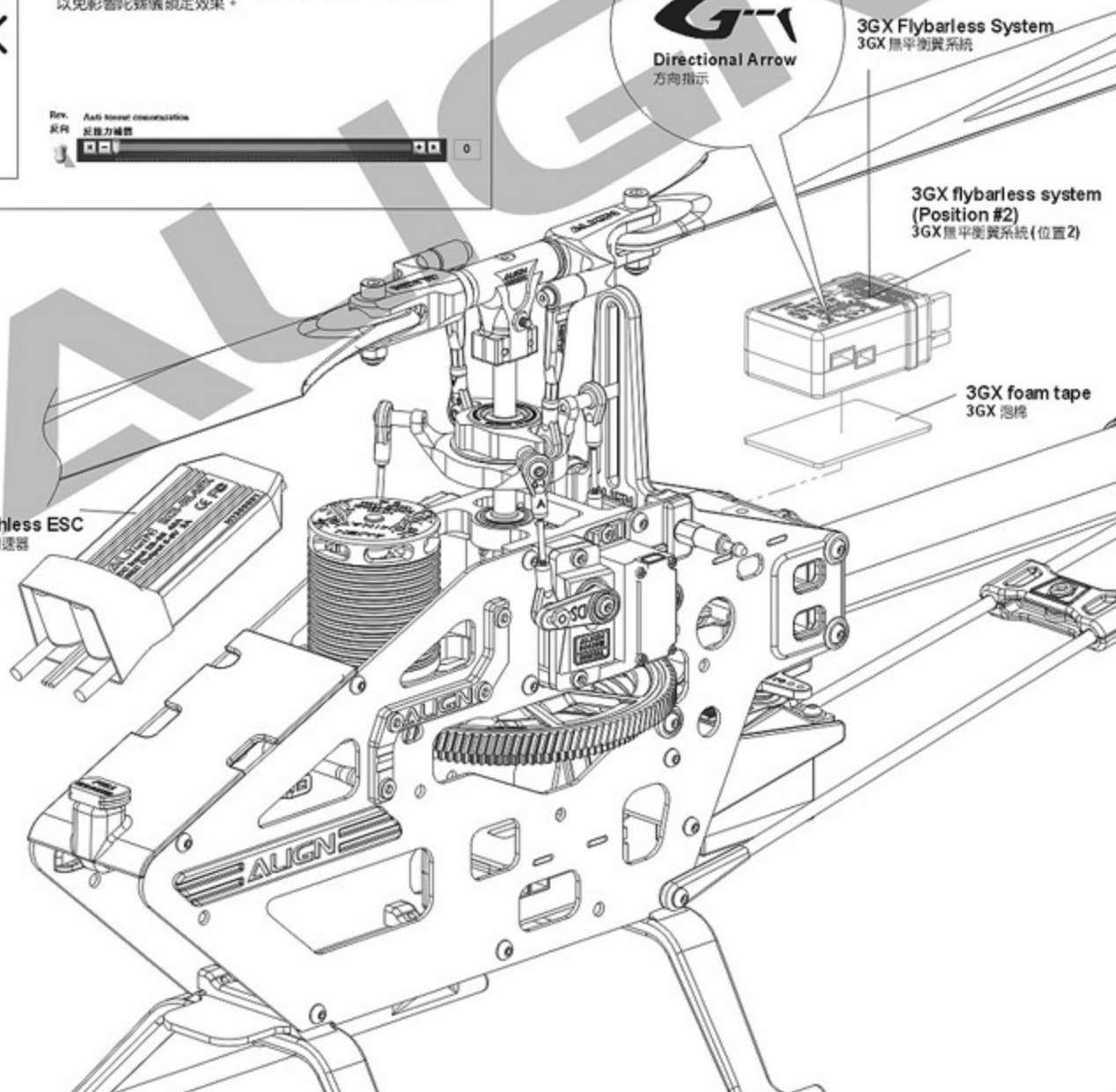

Slide the battery mounting plate along the rail until a "click" is heard to make sure the battery mounting plate is latched.

將電池固定板順著電池滑軌裝入至發出"喀答"聲響，使電池固定板卡入卡榫。

While drawing out the battery, pull this latch to allow the battery to slide out along the rail.

電池抽出時，請先將拉扣往上拉順著滑軌抽出。

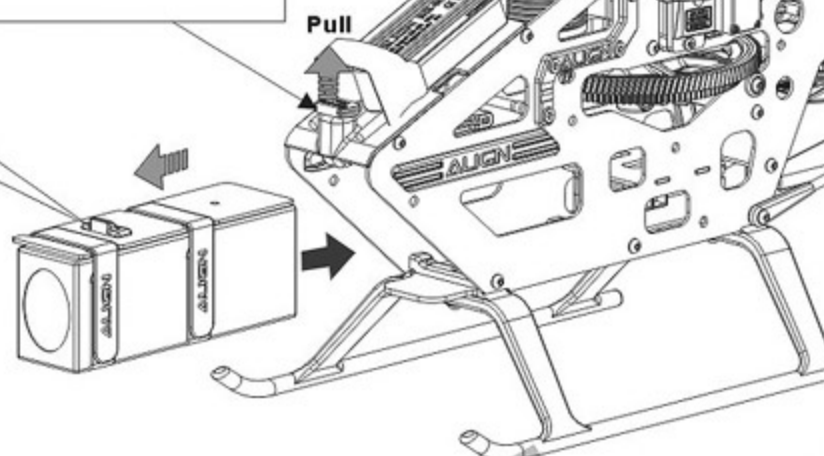
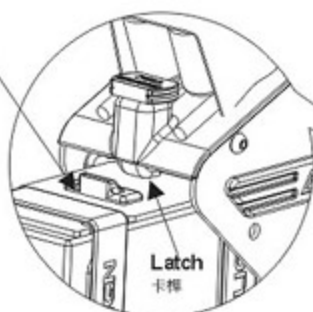

Please attach the hook & loop tape to narrow side of battery.

魔術沾請黏貼在電池的較窄面。

Use the included hook & loop strap to fix the battery in place. Start the strap 1cm below the battery mounting plate, go down along the battery until it wraps around completely. The end of the strap also needs to be 1 cm away from the battery mounting plate.

以附贈的魔術束帶來固定電池。束帶需從電池板下方1公分處，沿電池由下往上方式綁，最後束帶末端也要離電池板1公分。

Battery mount
電池固定板

Hook and loop tape
(hooked)
魔術沾(勾狀)

Hook and loop tape
(fuzzy)
魔術沾(絨毛狀)

Battery
電池

1 cm above
1公分以上

Hook and Loop Strap
魔術帶

1 cm above
1公分以上

9. CANOPY ASSEMBLY 機頭罩安裝

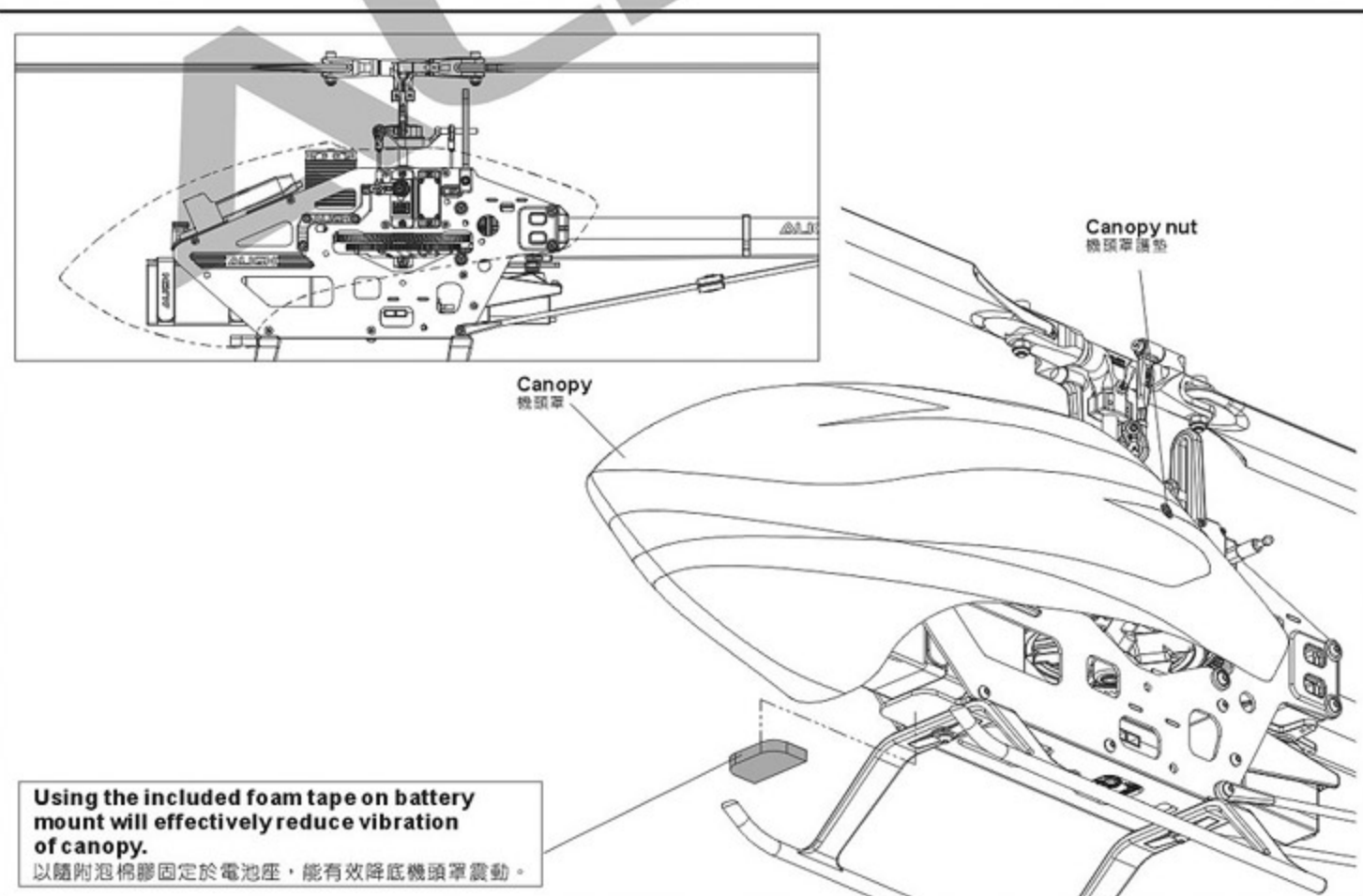

Using the included foam tape on battery mount will effectively reduce vibration of canopy.

以隨附泡棉膠固定於電池座，能有效降低機頭罩震動。

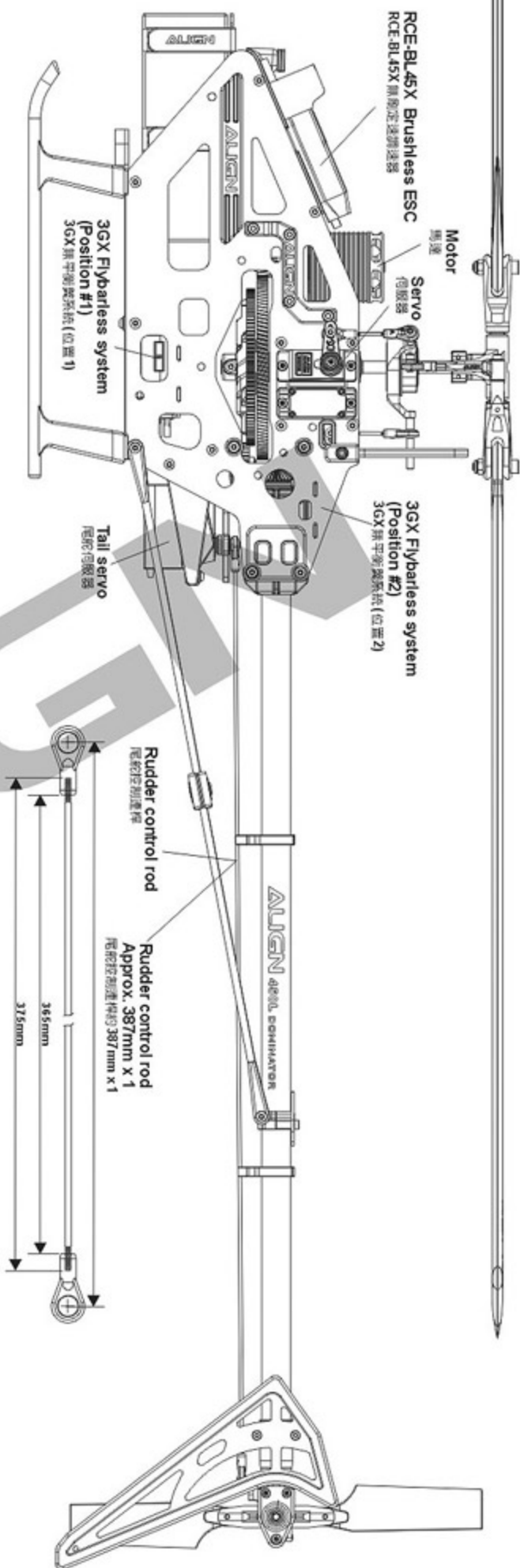

PARTS IDENTIFICATION 各部位名稱

3GX FLYBARLESS SYSTEM 3GX 無平衡翼系統組

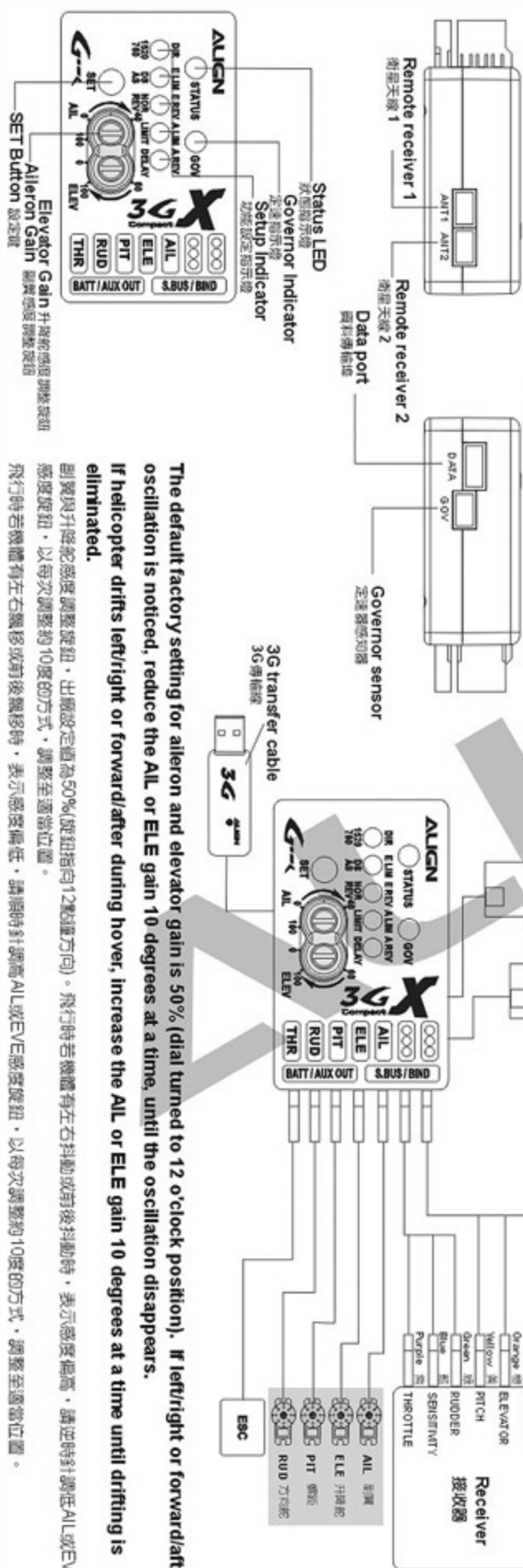

The default factory setting for aileron and elevator gain is 50% (dial turned to 12 o'clock position). If left/right or forward/aft oscillation is noticed, reduce the ALL or ELE gain 10 degrees at a time, until the oscillation disappears.

If helicopter drifts left/right or forward/aft during hover, increase the ALL or ELE gain 10 degrees at a time until drifting is eliminated.

副翼與升降舵感度調整旋鈕，出廠設定為50%(旋鈕指向12點鐘方向)。飛行時若機體有左右抖動或前後抖動時，表示感度偏高，請逆時針調低ALL或ELE感度旋鈕，以每次調整約10度的方式，調整至適當位置。

飛行時若機體有左右飄移或前後飄移時，表示感度偏低，請順時針調高ALL或ELE感度旋鈕，以每次調整約10度的方式，調整至適當位置。

To set this option is to turn on the transmitter and connect to the helicopter power. Note: For the safety, please do not connect ESC to the brushless motor before the setting in order to prevent any accident caused by the motor running during the setting. 此項設定只要開啓發射器，接上直昇機電源即可進行操作。注意：為了安全起見，設定前請先不要將無刷調速器與無刷馬達三條線接上，以免調整時啓動馬達而發生危險。

JR TRANSMITTER/SERVO JR遙控器對應伺服器關係

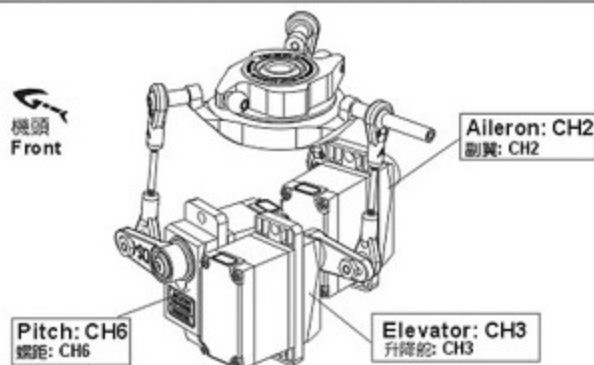

Positions of CH2 - CH6 are not exchangeable, After assembling as photo (Note: Set the transmitter under CCPM 120 degrees mode), pull throttle stick (pitch) upward. If one swashplate servo (or two servos) moves downward, adjust reverse switch (REV) on the transmitter to make it moves upward. If three servo move downward, adjust the travel value (+-) of SWASH PIT on the transmitter to make them move upward. When the actions of Aileron and Elevator are opposite, adjust travel values of SWASH AIL and ELE.

CH2、CH6不可互換配置，依圖連結後(注意：遙控器須設定於CCPM 120°十字盤模式)，將油門搖桿(Pitch)往上推，若十字盤伺服器有1個或2個往下移時，請調整遙控器的反轉開關(REV)使伺服器往上，若3個伺服器同時往下移時，請調整遙控器 SWASH PIT 行程量的正負值，使伺服器同時往上平移，副翼與前後動作相反時，同樣調整 SWASH AIL、ELE 行程量正負值。

FUTABA/HITEC TRANSMITTER/SERVO FUTABA/HITEC 遙控器對應伺服器關係

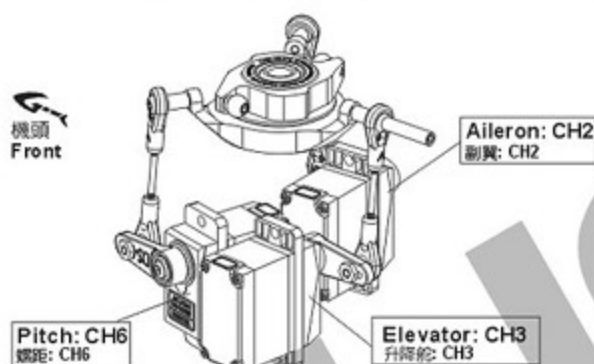

Positions of CH1 - CH6 are not exchangeable, After assembling as photo (Note: Set the transmitter under CCPM 120 degrees mode), pull throttle stick (pitch) upward. If one swashplate servo (or two servos) moves downward, adjust reverse switch (REV) on the transmitter to make it moves upward. If three servo move downward, adjust the travel value (+-) of SWASH PIT on the transmitter to make them move upward. When the actions of Aileron and Elevator are opposite, adjust travel values of SWASH AIL and ELE.

CH1、CH6不可互換配置，依圖連結後(注意：遙控器須設定於CCPM 120°十字盤模式)，將油門搖桿(Pitch)往上推，若十字盤伺服器有1個或2個往下移時，請調整遙控器的反轉開關伺服器往上，若3個伺服器同時往下移時，請調整遙控器 (REV)使伺服器往上，若3個伺服器同時往下移時，請調整遙控器 SWASH PIT 行程量的正負值，使伺服器同時往上平移，副翼與前後動作相反時，同樣調整 SWASH AIL、ELE 行程量正負值。

12.ADJUSTMENTS FOR GYRO AND TAIL NEUTRAL SETTING 陀螺儀與尾翼中立點設定調整

Turn off Revolution mixing(RVMX) mode on the transmitter, then set the gain switch on the transmitter and the gyro to non-Head lock mode, or disable gain completely. After setting the transmitter, connect the helicopter power and proceed with rudder neutral point setting. Note: When connecting to the helicopter power, please do not touch tail rudder stick and the helicopter, wait for 3 seconds for gyro to enable, and the rudder servo horn should be 90 degrees to the tail control pushrod. Tail pitch slider should be halfway on the tail output shaft. This will be the standard rudder neutral point. After completing this setting, set the gain switch back to heading lock mode, with gain at around 70%.

發射器內陀螺儀設定請關閉根軸混控模式，並將發射器上的感度開關與陀螺儀切至“非鎖定模式”或將陀螺儀感度關閉。發射機設定完成後接上直昇機電源，即可進行尾舵中立點設定。注意：當接上直昇機電源時請勿撥動尾舵搖桿或碰觸機體，待3秒陀螺儀開機完成後，尾伺服器需與尾伺服器約成90度，尾旋翼控制組須正確置於尾橫軸約中間位置，即為標準尾舵中立點設定，設定完成後，切換至“鎖定模式”，感度設約70%左右。

TAIL NEUTRAL SETTING 尾中立點設定

After the gyro is enable and under non-Head lock mode, correct setting photo. If the tail pitch assembly is not in the middle position, please adjust the length of rudder control rod to trim.

陀螺儀開機後，在非鎖定模式下，尾伺服器與尾Pitch控制組正確置位置。

若尾Pitch控制組未置中時請調整尾控制連桿的長度來修正。

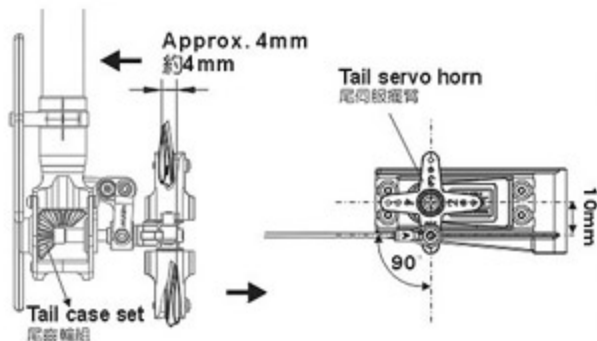

HEAD LOCK DIRECTION SETTING OF GYRO 陀螺儀鎖定方向設定

To check the head lock direction of gyro is to move the tail counterclockwise and the tail servo horn will be trimmed clockwise. If it trims in the reverse direction, please switch the gyro to "REVERSE".

陀螺儀鎖定方向確認，當手搖尾部反時鐘擺動，尾伺服器應反時鐘修正，反向時請切換陀螺儀上“鎖定反向”開關修正。

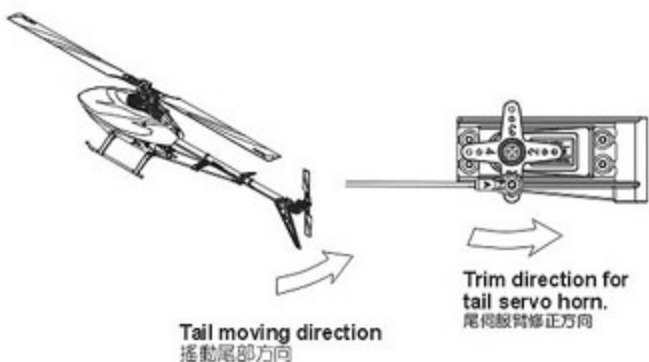

GENERAL FLIGHT 一般飛行模式

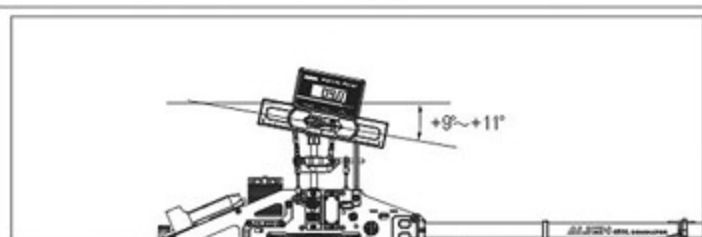

Stick position at high/Throttle 100%/Pitch +9°~+11°
搖桿高速/油門100%/Pitch +9°~+11°

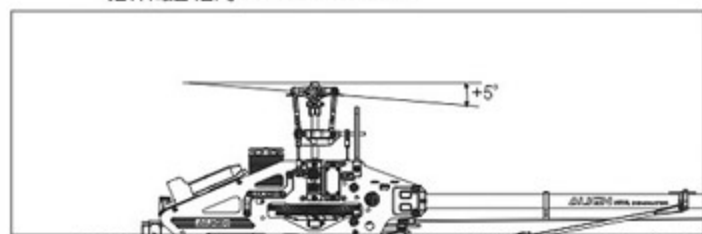

Stick position at Hovering/Throttle 65%~70%/Pitch +5°~+6°
搖桿停懸/油門65%~70%/Pitch +5°~+6°

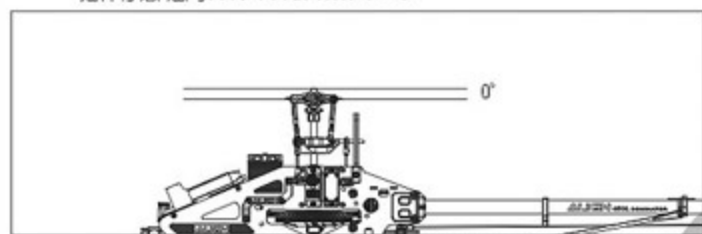

Stick position at low/Throttle 0%/Pitch 0°~-2°
搖桿低速/油門0%/Pitch 0°~-2°

3D FLIGHT 3D特技飛行模式

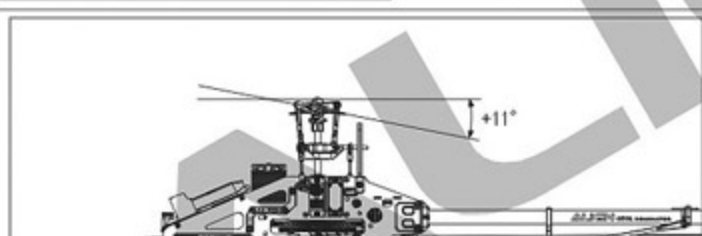

Stick position at high/Throttle 100%/Pitch +11°
搖桿高速/油門100%/Pitch +11°

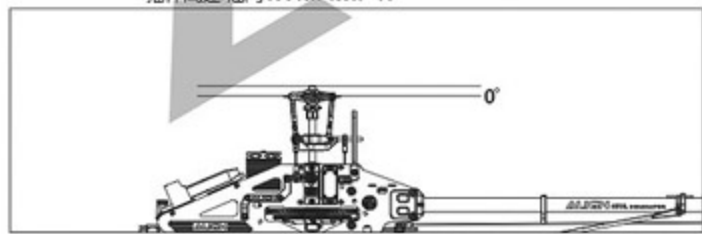

Stick position at middle/Throttle 90%/Pitch 0°
搖桿中速/油門90%/Pitch 0°

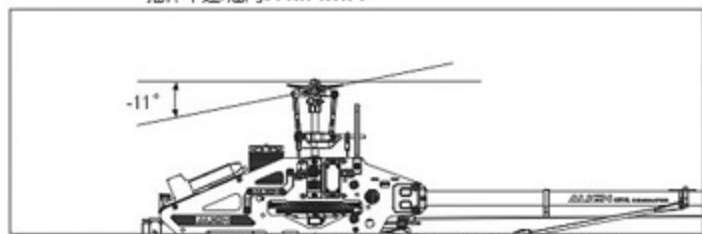

Stick position at low/Throttle 100%/Pitch -11°
搖桿低速/油門100%/Pitch -11°



1. Pitch range: Approx. 25 degrees.
 2. If the pitch is set too high, it will result in shorter flight duration and poor motor performance.
 3. Setting the throttle to provide a higher speed is preferable to increasing the pitch too high.
1. 螺距(Pitch)總行程約 25°
 2. 過大螺距設定，會導致動力與飛行時間降低。
 3. 動力提昇以較高轉速的設定方式，優於螺距調大的設定。

GENERAL FLIGHT
一般飛行模式

	Throttle 油門	Pitch 螺距
5	100% High speed 100% 高速	+9°~+11°
4	85%	
3	65%~70% Hovering 65%~70% 停懸	+5°
2	40%	
1	0% Low speed 0% 低速	0°~-2°

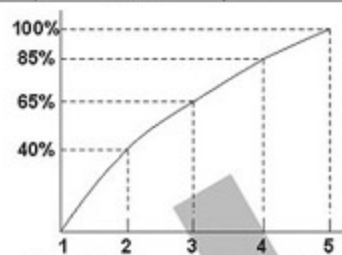

Throttle Curve (Hovering Flight)
停懸模式油門曲線

IDLE 1: SPORT FLIGHT

	Throttle 油門	Pitch 螺距
5	100%	+11°
4	80%	
3	80%	+5°
2	80%	
1	90%	-5°

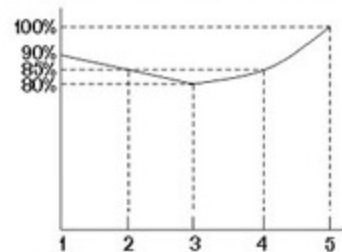

Throttle Curve (Simple Aerobatic Flight)
空中飛行模式油門曲線

IDLE 2: 3D FLIGHT

	Throttle 油門	Pitch 螺距
5	100% High 100% 高	+11°
3	90% Middle 90% 中	0°
1	100% Low 100% 低	-11°

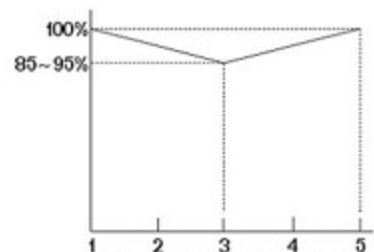

Throttle Curve (3D Flight)
特技飛行模式油門曲線

FEATURES 產品特色

- 3AxDs** 3-axis gyroscopic flybarless system to simulate the stability of mechanical flybar system, yet at the same time achieving agile 3D performance.
3軸陀螺儀無平衡翼系統，可模擬有平衡翼系統的穩定性，更有靈活的3D性能。
- MEMS** Utilizes MEMS gyro sensors, which feature small footprint, high reliability, and excellent stability.
採用MEMS (Micro Electro Mechanical Systems) 微機電系統技術感測器，具有體積小，可靠性高，穩定性佳的優點。
- 12bit** Sensor with 12 bit ultra high resolution, resulting in highly precise controls.
感測器12位元，超高解析度，控制絕無精準。
- APS** Supports APS Gyro.
支援APS陀螺儀。
- SPEKTRUM** Supports Spektrum and JR satellite receivers.
支援SPEKTRUM與JR衛星天線。
- S.BUS** Supports Futaba S.Bus architecture.
支援Futaba S.BUS功能。
- PC** Software upgradable through PC interface adapter.
具備可升級程式化介面，可透過傳輸線更新軟體。
- Easy** Simplistic setup process without the need of external devices. Setup is done through 5 steps and 2 sensitivity adjustments. Rudder setup is identical to GP780 gyro, minimizing learning curve.
設定簡單不需額外的介面，只需五個步驟、兩個感度調整即可完成所有設定，尾舵設定和GP780相同，設定輕鬆上手。
- Energy** Flybarless system dramatically improves 3D power output and efficiency, resulting in reduced fuel or electricity consumption.
無平衡翼系統，可大幅降低3D大動作飛行能量消耗，提供直昇機更大的動力輸出且更加節省燃油或電力。
- Stable** Highly sensitive gyroscopic sensors combined with advanced control detection routine providing higher hovering and aerobatic stability than other flybarless system.
高感度陀螺感測器及先進環路設計，可提供比一般平衡翼系統更佳的靜態及動態穩定性。
- CCPM** Suitable for all CCPM and mechanical mixing system.
適用於任何比例之對稱式三伺服器CCPM系統及傳統十字盤系統。
- GOV** Built in speed governor function.
內建定速器功能。
- T-REX 250-800** Comaptible with helicopter of all sizes from T-REX 250 to T-REX 800.
3GX Flybarless電子設備相容迷你型直昇機至大型直昇機T-REX 250~T-REX 800。
- 3.5V-8.4V** Capable to operate between 3.5V to 8.4V, compatible with high voltage servos.
適用電壓3.5V~8.4V，支援高電壓伺服器。
- Small** Small footprint, light weight, minimalists and reliable design.
體積小、重量輕，構造簡單可靠，提供操控者高性能的飛行樂趣。
- RoHS** RoHS certified.
符合RoHS限用規章。

3GX FLYBARLESS SETUP INDICATORS 功能設定指示燈說明

FLYBARLESS SYSTEM SETUP MODE 無平衡翼系統設定模式：

DIR	E.LIM	E.REV	A.LIM	A.REV
Direct mode bypassing gyro for mechanical travel and neutral point setup. 機械行程與中立點設定	Collective mixing type recognition and elevator endpoint settings 混控辨識及升降舵行程設定	Elevator reverse settings 升降舵正反向設定	Aileron endpoints settings 副翼行程設定	Aileron reverse settings 副翼正反向設定

RUDDER GYRO SETUP MODE 尾舵陀螺儀設定模式：

1520/760	DS/AS	NOR/REV	LIMIT	DELAY	Anti-torque compensation direction setting
Servo frame rate settings (1520 μs and 760 μs) 寬頻1520 μs及窄頻760 μs伺服器設定	Digital/Analog servo settings 數位及類比伺服器設定	Rudder Servo Reverse settings 尾舵陀螺儀正反向設定	Rudder endpoints settings 尾舵行程設定	Rudder servo delay, and helicopter size settings 尾舵延遲量及大小直昇機模式設定	Anti-torque compensation direction setting 反扭力補償正反向設定

SETUP PRE-CHECK 設定前注意事項



While using 3GX FBL system, be sure to turn off the following functions in the transmitter
 使用3GX系統若是遙控器有下列功能時請勿開啟功能
 * Swash Ring * Linkage Compensation * Swash Mix * Mixing * Acceleration

1. Connect the receiver and servos to the flybarless control unit as per diagram found on page 22~23 .
 2. Digital servos must be used on cyclic to avoid damage to servos.
 Commended servo spec: minimum speed 0.09 sec/60°, torque 2.2kg.cm or higher.
 3. The trim must be zero when using 3GX, and should not be adjusted at anytime. If the helicopter hovering tend to one side, it means the swashplate doesn't keep horizontal when setting. Go to flybarless system "Direct mode bypassing gyro, for mechanical travel and neutral point setup" to adjust the level of the swashplate and then re-complete the setup.
 4. When the 3GX flybarless system is installed for the first time, a few simple setup steps and fly tests need to be performed in the flybarless setup mode. These steps need to be performed only during initial setup, and does not need to be repeated for subsequent flights. Just power up the system normally, check the proper servo operations, and fly. The initial setup procedure only need to be repeated after software upgrade, pitch range reset, or subtrims are added in the transmitter.
1. 將接收器及伺服器依接線示意圖連接 (請參照第22~23頁)。
 2. 十字盤必須安裝數位伺服器, 否則會造成伺服器損毀。建議規格: 速度0.09秒/60°以內; 扭力2.2kg.cm以上。
 3. 進入設定前必須將遙控器的外微調歸零, 飛行時不可調整外微調, 若直升機停懸時偏向某一邊移動, 表示設定時十字盤未保持水平, 請進入無平衡翼系統"機械行程與中立點設定", 調整十字盤量水平後, 重新完成設定。
 4. 第一次安裝3GX Flybarless無平衡翼系統時, 必須進入無平衡翼設定模式, 進行幾項簡易的安裝設定與飛行測試, 完成後即不須再進入此設定模式, 只要正常開機, 檢查伺服器動作正確後即可飛行; 除非要更新程式、重設螺距或有更動遙控器內微調(sub.trim)時, 必須進入設定模式重設無平衡翼系統。

3GX CONNECTIVITY METHOD 3GX接線方式

METHOD 1: STANDARD RECEIVER CONNECTIVITY METHOD 方式一: 傳統接收器接線法

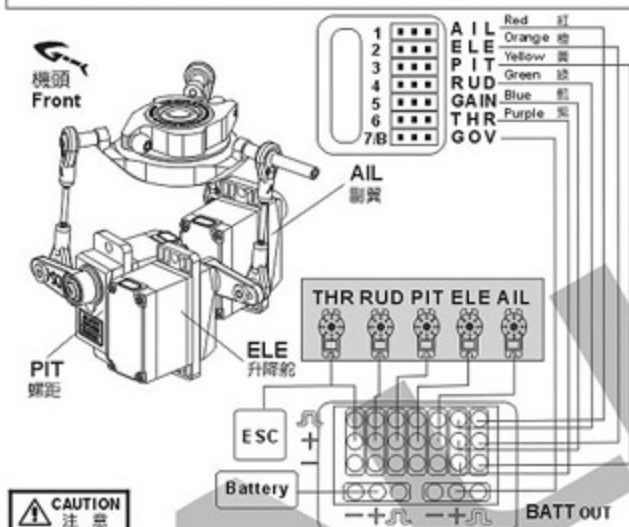

1. Connect all wires as shown in diagram. Receiver and 3GX wires are color coded to distinguish the different connection channels. Care should be taken to ensure proper wire color to channel connection.
2. While using the speed controller that not including BEC, you need to connect the BEC power with 3GX "BATT" port.
3. Receiver power is achieved by connecting the 3GX "S.BUS/BIND" port to the ch7 or BATT port on receiver using supplied signal wire.
4. To avoid damage to servos, only digital servos should be used for swashplate. Recommended spec: 0.09s/60° or faster, with 2.2 Kg or higher torque.
5. 3GX has built in speed governor function which can be utilized by purchasing the optional speed sensor. Governor setting is done through channel 7 on the receiver.

1. 請依照圖示進行接線, 接收器與3GX的接線使用不同的顏色來區分不同的通道, 接線時請注意各顏色所對應的通道。
2. 使用無BEC輸出的調速器時, 須額外由3GX的"BATT"孔位接入BEC電源。
3. 接收器電源請以隨附的訊號線由3GX的"S.BUS/BIND"孔位接至第七通道或BATT通道。
4. 十字盤必須安裝數位伺服器, 否則會造成伺服器損毀。建議規格: 速度0.09秒/60°以內; 扭力2.2kg以上。
5. 3GX內建定速器功能, 可另購定速器感知器使用, 轉速設定由接收器的第七通道設定。



Do not exchange AIL and PIT connections
 AIL及PIT不可對調。

METHOD 2: FUTABA S.BUS CONNECTIVITY METHOD 方式二: Futaba S.BUS接線法

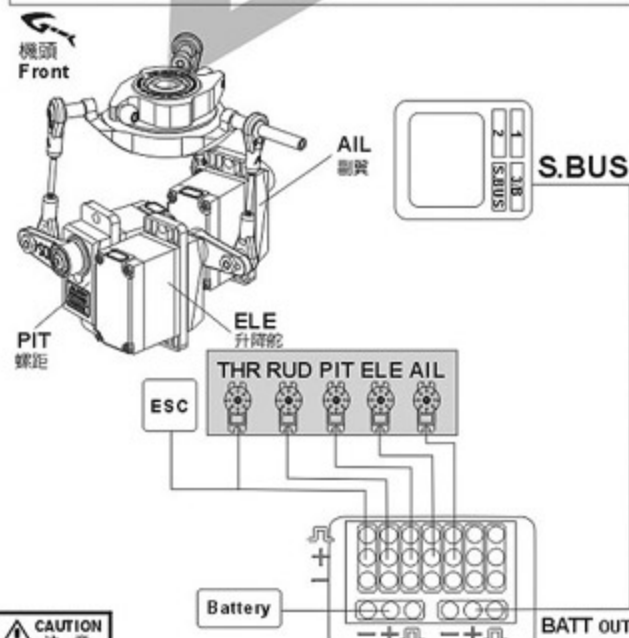

1. For Futaba S.BUS receivers, connect wires as shown in diagram.
2. While using the speed controller that not including BEC, you need to connect the BEC power with 3GX "BATT" port.
3. Receiver power is supplied through S.BUS signal wire connected to 3GX's "S.BUS/BIND" port.
4. The default channel/function mapping when using S.BUS are:
 (1)AIL (2)ELE (3)THR (4)RUD (5)GAIN (6)PIT (7)GOV

1. 具備S.BUS功能的Futaba接收器, 請依照圖示進行接線。
2. 使用無BEC輸出的調速器時, 須額外由3GX的"BATT"孔位接入BEC電源。
3. 接收器電源共同由S.BUS訊號線接至3GX的"S.BUS/BIND"孔位。
4. 使用S.BUS功能時, 內部通道已指定為:
 (1)AIL (2)ELE (3)THR (4)RUD (5)GAIN (6)PIT (7)GOV

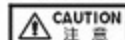

If channel 3 is set as PIT and channel 6 set as THR on transmitter, such as 8FG, 12Z, 14MZ, and etc, please reprogram the transmitter to utilize channel3 as THR and channel6 as PIT.

若所使用的遙控器內部指定(3)通道為PIT (6)通道為THR時, 例如8FG、12Z、14MZ等, 請更改遙控器上的設定為(3)通道 THR (6)通道 PIT。

5. To avoid damage to servos, only digital servos should be used for swashplate.
 Recommended spec: 0.09s/60° or faster, with 2.2Kg or higher torque.
6. 3GX has built in speed governor function which can be utilized by purchasing the optional speed sensor. Governor setting is done through channel 7 on the receiver.
5. 十字盤必須安裝數位伺服器, 否則會造成伺服器損毀。
 建議規格: 速度0.09秒/60°以內; 扭力2.2kg以上。
6. 3GX內建定速器功能, 可另購定速器感知器使用, 轉速設定由接收器的第七通道設定。



Do not exchange AIL and PIT connections
 AIL及PIT不可對調。

METHOD 3: JR/SPEKTRUM SATELLITE CONNECTIVITY METHOD 方式三:JR/SPEKTRUM衛星天線接線法

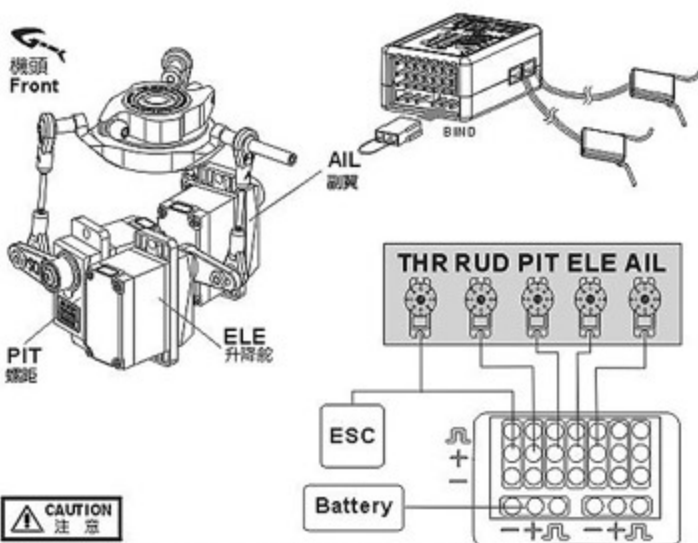

Do not exchange AIL and PIT connections
AIL及PIT不可對調。



1. Do not mix satellite receivers of different makes.
2. Even under correct startup sequence, if transmitter is powered off first, LED1~LED5 will also flash. Thus the receiver should always be powered off before the transmitter.
3. 3GX supports satellite receiver models currently available on the market. Should new receiver version comes out with compatibility issues, firmware will be updated to resolve any incompatibility that may arise.

1. 不同廠牌的衛星天線請勿交叉對頻。
2. 正常開機的情況下，如果先關發射機，也會發生LED1~LED5持續閃爍情況，所以請養成先關接收機，再關發射機的良好習慣。
3. 如有新型號衛星天線產生不相容情形，將以韌體更新方式解決。

FAILSAFE(LAST POSITION HOLD) 失控保護(保留最後指令)：

When helicopter lost connectivity with your radio under this setting, all channels will hold at the last command position, except throttle channel which goes to a preset position.

1. Push throttle stick to the desired fail safe position.
2. Plug the binding plug into 3GX's BIND port, and perform radio binding steps.
3. After successful binding, do not power off the 3GX, unplug the binding plug and allow 3GX to enter initializing process. The last position hold function will be active after the 3GX initializes.
4. Test Method: Power off transmitter. The throttle channel should move to preset position, while all other channels should hold in their last position.

FAILSAFE (PRE-SET POSITION HOLD) 失控保護(回復預設值)：

When helicopter lost connectivity with your radio under this setting, all channels will move to the pre-set position.

1. Plug the binding plug into 3GX's BIND port, and power up the 3GX. After the rapid flash of satellite's LEDs, pull the binding plug off.
2. Power up radio transmitter, and perform radio binding steps. After radio is bound, LED on the satellite antennas will end the rapid flash, following by slower flash.
3. Move the transmitter sticks to the desired failsafe position while the LED is flashing in slower mode.
4. Satellite antenna's LED will lit up after 5 seconds, and 3GX goes through initializing process. The failsafe position will be set after the 3GX initializes.
5. Test Method: Power off transmitter, and all channels should move to the pre-set failsafe position.

1. For JR or Spektrum satellite receivers, connect wires as shown in diagram.
2. While using the speed controller that not including BEC, you need to connect the BEC power with 3GX "BATT" port.
3. To avoid damage to servos, only digital servos should be used for swashplate. Recommended spec: 0.09s/60° or faster, with 2.2Kg or higher torque.
4. 3GX has built in speed governor function which can be utilized by purchasing the optional speed sensor. Governor setting is done through channel 7 on the receiver. Channel5/GEAR controls RPM of speed governor, channel7/AUX2 controls rudder gyro gain. For radios with less than 6 channels, please use the standard receiver connectivity method.
5. For radios with less than 6 channels, channel5/GEAR is used for rudder gyro gain. Speed governor cannot be used. For safety concern, two satellite receivers should be used, with each antenna perpendicular (90 degrees) from each other. A satellite receiver should be installed on each side of the frame, separate by minimum distance of 5cm.
6. Should both satellite receivers loose connectivity during flight, LED1 ~ LED5 will flash continuously as warning. A single power cycle of the system will not clear this error. The system need to be power cycled the second time to reset.

7. Default channel/function mapping when using satellite receiver are:
(1)THR (2)AIL (3)ELE (4)RUD (5)GOV (6)PIT (7)GAIN
1. 請依照圖示進行接線，3GX支援Spektrum與JR系統衛星天線。
 2. 使用無BEC輸出的調速器時，須額外由3GX的"BATT"孔位接入BEC電源。
 3. 十字盤必須安裝數位伺服器，否則會造成伺服器損毀。建議規格：速度0.09秒/60°以內；扭力2.2kg以上。
 4. 3GX內建定速器功能，可另購定速器感知器使用。七動及七動以上遙控器(5)GEAR控制定速器轉速，(7)AUX2控制尾舵陀螺儀感度。六動以下遙控器請使用傳統接線方式。
 5. 為安全起見，請盡量安裝兩個衛星天線，兩個衛星天線角度除必須呈90度之外，且須安裝於機身兩側，相隔至少5公分以上。
 6. 如果飛行途中有兩個衛星天線同時失連的情形，LED1~LED5會持續閃爍警告，在此情形下就算重新開機，LED1~LED5會持續閃爍而無法開機，必須再重新開機一次，才可正常運作。
 7. 使用衛星天線接線時，內部通道已指定為：
(1)THR (2)AIL (3)ELE (4)RUD (5)GOV (6)PIT (7)GAIN

在此模式下，若您的音響機與遙控器失連，除油門頻道為預設位置，其餘頻道皆為最後指令位置。

1. 將油門搖桿放置於您所需要的預設安全位置
2. 將對頻接頭插在3GX的BIND插座，執行與遙控器的對頻動作。
3. 與遙控器完成對頻動作後，不要關閉3GX電源，先將對頻接頭拔除，3GX會進入開機狀態，待3GX開機完成後，即完成保留最後指令設定。
4. 測試方法：將遙控器開機，除了油門頻道為預設安全位置外，其餘頻道都為失連前的最後指令位置。



When using DSMX remote receiver, need to press 3GX SET bottom first, then turn on the power and start binding process.
如果使用 DSMX 衛星天線，請先按著 3GX SET 鍵，再開啟電源對頻。

在此模式下，若您的音響機與遙控器失連，所有頻道為預設安全位置。

1. 將對頻接頭插在3GX的BIND插座，先開啟3GX電源，待衛星天線上LED快速閃爍後，將對頻接頭拔除。
2. 開啟遙控器電源，執行與遙控器的對頻動作，對頻完成瞬間，衛星天線上LED會由快速閃爍狀態熄滅，之後再亮起改為慢速閃爍。
3. 在慢速閃爍狀態時，將遙控器上的所有搖桿放置於您所需要的預設安全位置。
4. 5秒後衛星天線LED燈為恆亮，3GX進入開機狀態，待3GX開機完成後，即完成失控保護設定。
5. 測試方法：將遙控器開機，所有頻道為預設安全位置。



When using DSMX remote receiver, need to press 3GX SET bottom first, then turn on the power and start binding process.
如果使用 DSMX 衛星天線，請先按著 3GX SET 鍵，再開啟電源對頻。

FLYBARLESS SYSTEM INITIAL SETUP STEPS 無平衡翼設定

1. DIR : Direct mode to bypassing gyro for mechanical travel and neutral point setup

DIR機械行程與中立點設定模式

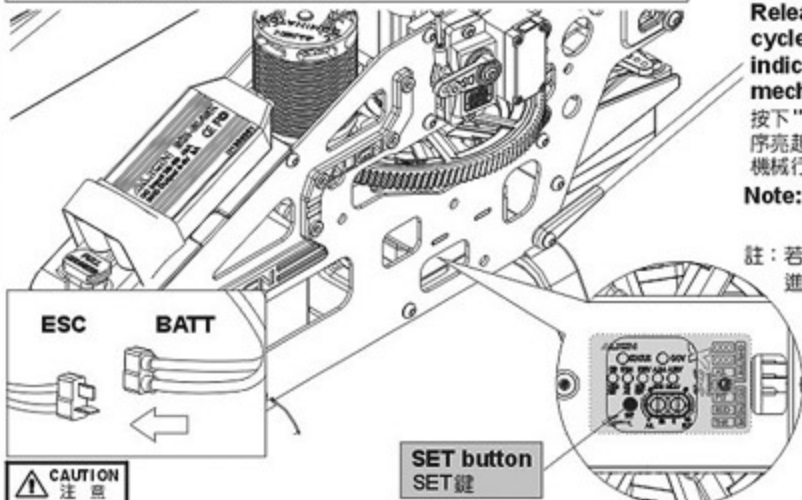

STEP1.1 : ENTER THE DIR SETTINGS

步驟 1.1 : 進入 DIR 設定

Press and hold the SET button while powering up the receiver. Release the button when LED 1-5 begin to cycle. Please power cycle to enter DIR mode. The DIR green LED will light up indicating the gyro has been bypassed for neutral and mechanical travel range setup.

按下 "SET" 鍵不放，並將接收器電源開啟，接著 LED1 ~ 5(DIR ~ A.REV) 會循序亮起，此時即可以放開按鍵(註)，"DIR"綠燈亮起，則進入 3GX Flybarless 機械行程與中立點設定模式。

Note: If pressed for more than 2 seconds, 3GX will enter 3GX throttle calibration mode. Re-power and enter DIR setting.

註：若按壓時間超過 2 秒，3GX 會進入 3GX 油门行程校正模式，請重新開電源進入 DIR 設定。



1. To set this option is to turn on the transmitter and connect to helicopter power. For the safety, please do not connect ESC to the brushless motor before the setting in order to prevent any accident caused by the motor running during the setting.
2. When entering setup mode during power up, 3GX will initiate startup process. Do not move the helicopter at this time, otherwise swashplate will be tilted after start up. Should this occurs, restart the setup mode.
3. If 3GX was to be mounted inverted, please enter connect anti-torque compensation section and set it as "reverse" (STATUS LED turns red); to avoid the effect of the performance of gyro lock.

1. 此項設定只要開啟發射器，接上直昇機電源即可進行操作。為了安全起見，設定前請先不要將無刷調速器與無刷馬達三條線接上，以免調整時啟動馬達而發生危險。

2. 當接上電源進入設定模式的同時，3GX 會啟動初始化的程序，此時請勿移動機身，以免造成開機後十字盤傾斜，發生此狀況時請重新進入設定模式。

3. 選擇 3GX 面板朝下的安裝方式時，請進入設定選項中的反扭力補償設定，並將反扭力補償設為 "反向" (STATUS 燈為紅燈)，以免影響陀螺儀鎖定效果。



TRANSMITTER FUNCTION TO SERVO MAPPING 遙控器對應伺服器關係

STEP1.2 : SWASHPLATE FUNCTION CHECK 步驟 1.2 : 十字盤作動確認

Servo on right side of heli frame is AIL, middle is ELE, left side is PIT. Do not exchange AIL and PIT connections, otherwise some compensation feature may be reversed.

機體右側伺服器為 AIL，中間為 ELE，左為 PIT，請注意 AIL 及 PIT 不可對調，否則可能造成有些修正會反向。

Verify the correct swashplate movements for PIT, AIL, and ELE inputs.

確認十字盤作動 PIT、AIL、ELE 是否正確。

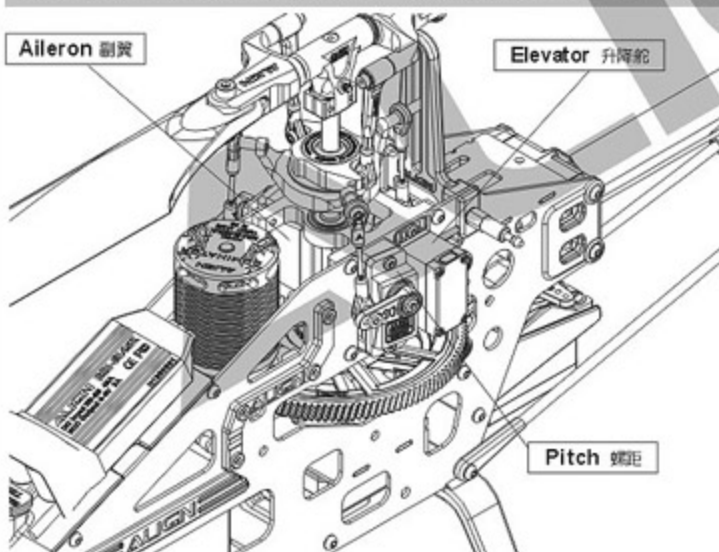

In case of incorrect servo movement or no movement at all, please check for proper connection between 3GX flybarless connection to servos, as well as proper setup on transmitter.
若作動錯誤或伺服器無動作，請檢查 3GX Flybarless 伺服器訊號線接線以及遙控器設定是否正確。

STEP1.3 : MECHANICAL SETUP 步驟 1.3 : 機械結構設定

Adjust the servo neutral point and main blade pitch.

請調整伺服器中立點、主旋翼角度 (如圖示)。



Pay extra attention to these setup steps. Incorrect neutral points will affect flight stability, and worse lead to loss of control.

本步驟請確實設定，若中立點不正確，不但影響飛行穩定性，更可能造成失控的危險。

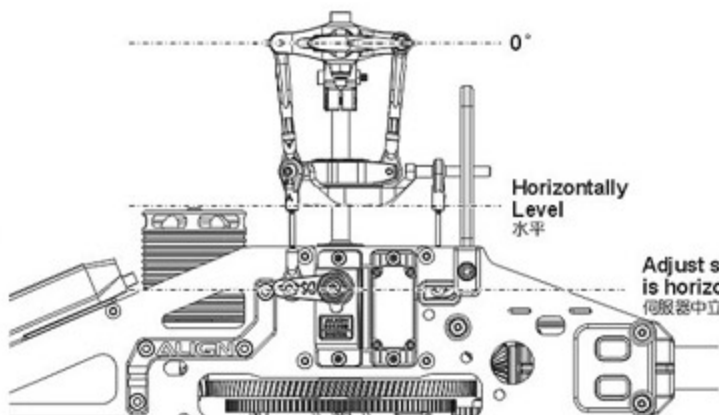

STEP1.4 : COLLECTIVE PITCH SETUP

步驟1.4 : 主旋翼螺距(集體螺距)設定

Adjust the maximum collective pitch using the transmitter's swashplate mixing function (pitch swash AFR). Recommended pitch range $\pm 9^\circ$, maximum pitch range for advanced pilot shall not exceed $\pm 12^\circ$.

建議螺距設定 $\pm 9^\circ$ ，高階使用者不超過 $\pm 12^\circ$ 為限。



Do not adjust individual servos endpoints through the servo ATV/AFR function, use only swashplate mixing adjustments. Should any changes made to the endpoints or subtrims on the transmitter in the future, the flybarless system initial setup must be performed again.

CCPM系統調整行程量時，須從遙控器Swash十字盤混控比率(Pitch swash AFR)調整，勿去調整個別伺服器的ATV行程量。

爾後遙控器的內微調如有變更，必須重新進行Flybarless各項設定。

While using 3GX FBL system, be sure to turn off the following functions in the transmitter

使用3GX系統若是遙控器有下列功能時請勿開啓功能

- * Swash Ring
- * Linkage Compensation
- * Swash Mix
- * Mixing
- * Acceleration

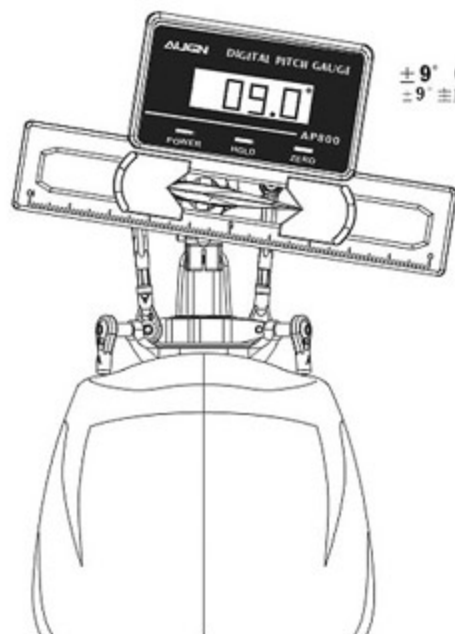

$\pm 9^\circ$ Collective pitch
 $\pm 9^\circ$ 主旋翼螺距

STEP1.5 : CYCLIC PITCH SETUP

步驟1.5 : 循環螺距設定

Swashplate cyclic pitch setting: With the main blades parallel to helicopter body, throttle stick positioned where main pitch is 0 degrees, move aileron stick all the way to the right, adjust the AIL mixing ratio within radio's SWASH menu so the main blade pitch is the factory recommended value ± 8 degrees. The ELE mixing ratio in SWASH menu can be set to the same value as AIL.

十字盤循環螺距設定：主旋翼方向與機體方向相同，油門搖桿置於主旋翼角度0度的位置不動，撥動副翼搖桿至最右，調整遙控器Swash中AIL比率，使主旋翼的攻角設定為原廠建議值 ± 8 度，搖控器Swash ELE比率請設定為與AIL比率相同即可。

If adjustments is needed for aileron and elevator roll rate, it can be done through 3GX interface's flight mode settings, or through 3GX PC interface.

若需調整副翼及升降舵轉速率時，可由3GX面板進入3GX飛行特性設定或透過3GX電腦介面調整。



Adjustments to the CCPM servos endpoints should be done through transmitter's swashplate mixing function (AIL swash AFR). Do not adjust individual servos endpoints through the servo ATV/AFR function. Should any changes made to the endpoints or subtrims on the transmitter in the future, the flybarless system initial setup must be performed again.

CCPM系統調整行程量時，從遙控器Swash十字盤混控比率做調整，勿去調整個別伺服器的ATV行程量。爾後遙控器內微調如有變更，必須重新進行Flybarless各項設定。



$\pm 8^\circ$ Cyclic pitch
 $\pm 8^\circ$ 循環螺距

Example: cyclic pitch of 8 :
 Futaba 14SG with three DS430M's
 AILeron swash AFR : 45% (8°)
 Elevator swash AFR : 45%
 Pitch swash AFR : 36% ($\pm 9^\circ$)
 例:以循環螺距設定8:
 Futaba 12SG 搭配 DS430M x3
 AILeron swash AFR : 45% (8°)
 Elevator swash AFR : 45%
 Pitch swash AFR : 36% ($\pm 9^\circ$)

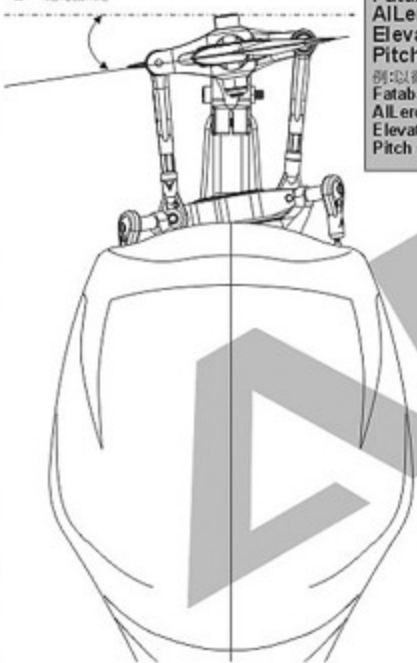

2. E.LIM swashplate mixing type recognition and elevator endpoint setup :

E.LIM十字盤混控辨識及升降舵行程量設定模式 :

STEP2.1 : ENTERING E.LIM SETUP MODE

步驟2.1 : 進入E.LIM設定

While keeping swashplate level and main pitch at zero degrees, press the SET button to register the neutral point and enter E.LIM setup mode. The E.LIM LED will lit up after DIR turns off.

保持十字盤為水平、旋翼角度為零度的狀態下，接著按下"SET"鍵DIR燈將熄滅，E.LIM燈將會亮起，進入"E·LIM升降舵行程量"設定模式。

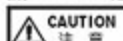

The throttle stick position where main pitch is 0 degree must be maintained through this setup process.

油門搖桿須置於主旋翼角度0度的位置，不可再移動。

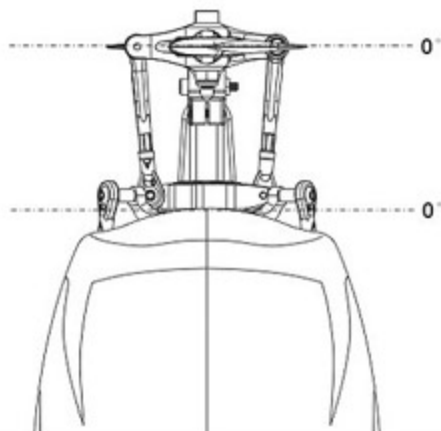

E.LIM settings
E.LIM模式



STEP2.2 : SWASHPLATE MIXING TYPE RECOGNITION AND ELEVATOR ENDPOINT SETUP

步驟2.2 : 十字盤混控辨識與升降舵行程量設定

With all channels stationary, move the transmitter elevator stick forward, and then back to center position. This completes the swashplate mixing type recognition process. The control unit will determine the CCPM mixing ratio or traditional mechanical mixing maximum elevator endpoints.

將遙控器升降舵推至最前方(請勿動到其他舵面動作), 再將升降舵搖桿放回中間位置, 完成此模式設定。

讓3GX Flybarless解算CCPM混控比例或傳統十字盤模式及前後可用行程。



注意

Throttle stick position where main pitch is 0 degree must be maintained through this setup process.
油門搖桿須置於主旋翼角度0度的位置, 不可再移動。

Throttle stick must be maintained
油門搖桿固定

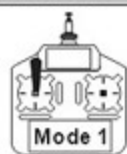

ELE

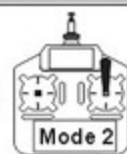

E.LIM settings
E.LIM模式

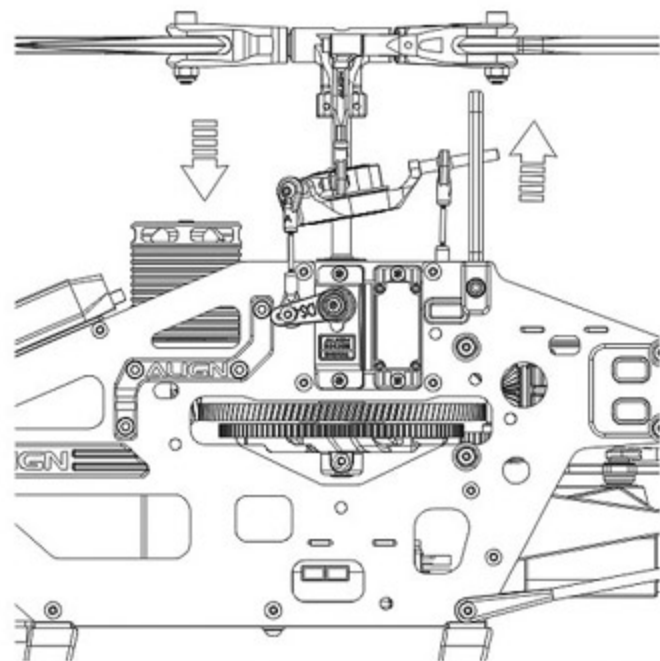
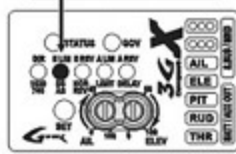

3. E.REV ELEVATOR REVERSE SETUP MODE :

E.REV升降舵陀螺儀正反向設定模式 :

Press the SET button to enter E.REV setup mode. The E.REV LED will lit up after E.LIM turns off. This setup mode sets the elevator gyro direction

1. Tilt the helicopter forward as shown in diagram, and check if swashplate is tilting correctly toward the back.
2. If the swashplate is tilting at the wrong direction, move the transmitter elevator stick until STATUS LED changes color, and re-check the swashplate tilting direction.

接著按下"SET"鍵, 讓設定模式進入"E.REV 升降舵陀螺儀正反向"設定模式, 此時E.LIM燈熄滅, E.REV燈亮起。此模式設定升降舵陀螺儀修正方向

1. 如圖示, 將機身向前傾確認十字盤的修正方向是否正確。
2. 如果十字盤方向修正錯誤, 請撥動升降舵搖桿改變STATUS燈顏色後, 再次確認十字盤修正方向是否正確。

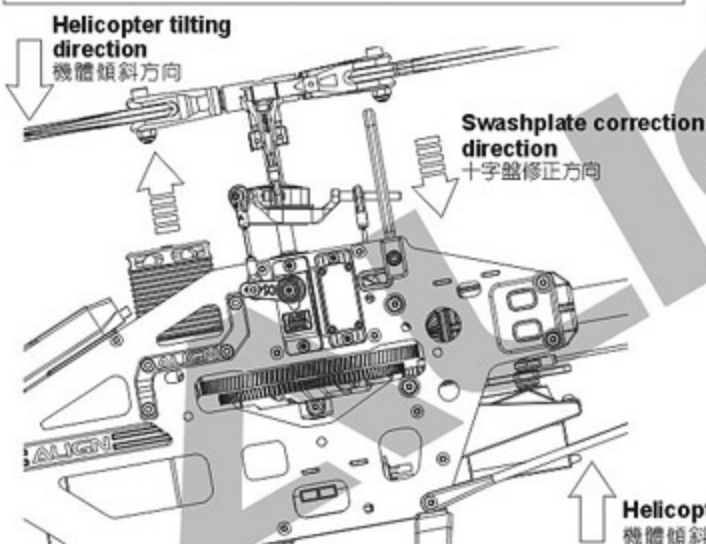

E.REV settings
E.REV模式

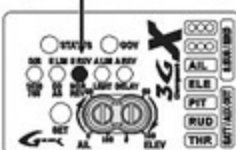

4. A.LIM AILERON ENDPOINTS SETUP :

A.LIM副翼行程量設定模式 :

Press the SET button to enter A.LIM setup mode. The A.LIM LED will lit up after E.REV turns off. With all channels stationary, move the transmitter aileron stick to the right, and then back to center position. This completes the aileron endpoint setup process. The control unit will determine the maximum aileron endpoints.

接著按下"SET"鍵, 讓設定模式進入"A.LIM副翼行程量"設定模式, 此時E.REV燈熄滅, A.LIM燈亮起。將副翼搖桿向右推到底, 完成後將搖桿置中, 完成此模式設定, 讓3GX Flybarless解算副翼可用行程。



注意

The throttle stick position where main pitch is 0 degree must be maintained through this setup process.
油門搖桿須置於主旋翼角度0度的位置, 不可再移動。

Throttle stick must be maintained
油門搖桿固定

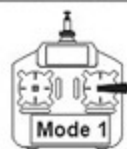

AIL

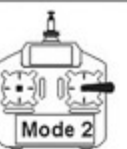

A.LIM settings
A.LIM模式

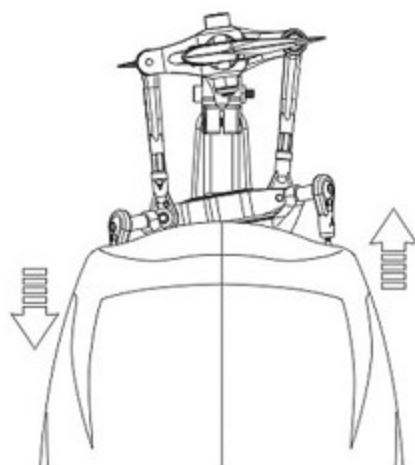
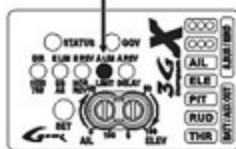

5. A.REV aileron reverse setup mode : A.REV 副翼陀螺儀正反向設定模式 :

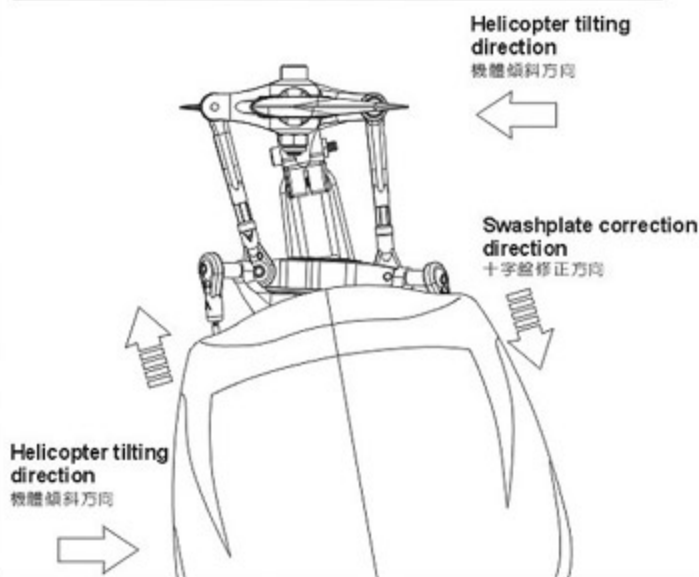

Press the SET button to enter A.REV setup mode. The A.REV LED will lit up after A.LIM turns off. Tilt the helicopter right as shown in diagram, and check if swashplate is tilting correctly toward the left. If the swashplate is tilting at the wrong direction, move the transmitter aileron stick until STATUS LED changes color, and re-check the swashplate tilting direction. Press the SET button again, and the control unit will restart with all LED's flashing. This completes the flybarless portion of the setup process.

接著按下"SET"鍵，讓設定模式進入"A.REV副翼陀螺儀正反向"設定模式，此時A.LIM燈熄滅，A.REV燈亮起。此模式設定副翼陀螺儀修正方向，如果將直昇機往右傾，3GX Flybarless應將十字盤向左傾修正，如果反向，可向左或向右推動副翼搖桿，變換"STATUS"不同顏色燈號，更換陀螺儀修正方向。接著按下"SET"鍵完成無平衡系統設定，所有LED將閃動，重新開機。



3GX Flybarless system must remain stationary during startup. Do not move the helicopter until the swashplate jumps up and down slightly 3 times, indicating the completion of initialization.
3GX Flybarless 開機時會進入初始化狀態，此時請勿移動機身，當初始化完成後，十字盤會保持水平上下小幅跳動3次，表示開機完成。

A.REV settings
A.REV模式

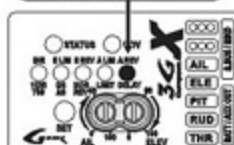

3GX THROTTLE CALIBRATION 3GX遙控器油門行程校正



For the safety, please do not connect ESC to the brushless motor before the setting in order to prevent any accident caused by the motor running during the setting.

為了安全起見，設定前請先不要將無刷馬達與無刷馬達二線板接上，以免調整時馬達運轉而發生危險。

While setting throttle calibration, reset throttle curve and pitch curve to default 0-50-100.

遙控器油門行程校正時，先將油門/俯仰曲線回復到預設0 50 100設定。

Throttle/Pitch curve
油門/俯仰曲線



Release SET button
放開SET鍵



Press 3GX SET button
按著3GX SET鍵不放



Move the throttle stick from lowest to highest point
將油門搖桿從最低點推至最高點位置



Turn on the receiver power
開啓接收機電源



After finish the setup, red and green LED start flashing and 3GX restarts
設定完成後，紅綠燈閃爍，3GX重新開啓

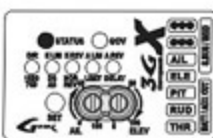

LED on 3GX panel all light up
讓3GX面板上LED依序亮起至全亮



Take off the receiver power
關閉接收機電源

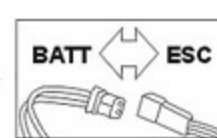

FLIGHT MODE SETTING 飛行特性設定

Operation Instruction

1. With 3GX in operation mode, push rudder to left or right, and press the SET button for about a second.
2. After entering setting mode, the STATUS LED will flash specific number of times to indicate specific settings.
3. During setting process, LED 1 to 5 indicate the rate of setting; flashing LED represents 10%, while steady lit LED represents 20%. For example, if LED 1 and LED2 are steady lit with LED3 flashing, the set rate is $2 \times 20 + 10 = 50\%$.

操作說明

1. 在3GX運作狀態中將尾舵搖桿扳至左邊或右邊不放，接著按SET鍵約一秒。
2. 進入設定後STATUS的燈號會以閃爍的次數代表所進入的選項。
3. 在設定過程中LED1-5代表設定值，LED閃爍代表10%，LED恒亮代表20%，例如LED1-LED2全亮，LED3閃爍，設定值為 $2 \times 20 + 10 = 50\%$ 。

The LED flashing frequency indicates setting position.
Single flash: Flip rate adjustment
Double flash: Elevator end point setting
Flash in group of 3: Aileron end point setting
Flash in group of 4: Swashplate dampening setting
Flash in group of 5: Swashplate accelerate setting

此燈閃爍次數為進入的程式介面位置：

閃爍次數1:滾轉速率調整
閃爍次數2:升降舵行程極限設定
閃爍次數3:副翼行程極限設定
閃爍次數4:十字盤柔化設定
閃爍次數5:十字盤加速設定

Fully lit LED1 indicates 20%
Fully lit LED2 indicates 20%
Flashing LED3 indicates 10%
So the setting value is $2 \times 20 + 10 = 50\%$.

LED1恒亮代表20%
LED2恒亮代表20%
LED3閃爍代表10%
故設定值為 $2 \times 20 + 10 = 50\%$ 。

Move rudder stick
撥動尾舵搖桿

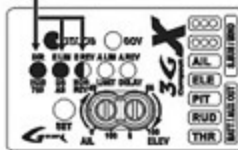
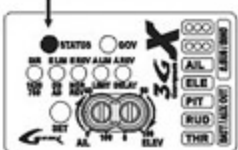

1. AILERON ROLL RATE ADJUSTMENT 滾轉速率調整

Setting Instruction:

1. After entering setting mode, STATUS LED flashes once.
2. Aileron and elevator rate can be adjusted independently.
3. Moving the aileron stick will display aileron roll rate on the LED. The more LEDs, the faster the roll rate. Moving the aileron stick can increase or decrease the number of LEDs that lights up between LED1 to LED5, which sets the aileron roll rate. Same method is used to adjust the elevator flip rate when elevator stick is moved.
4. Elevator flip rate is adjusted based on aileron roll rate. When the difference between elevator flip rate and aileron roll rate differs by 20% or more, 3GX will automatically adjust until the error rate falls within range. Therefore, we recommend adjustment aileron roll rate first, and then adjust elevator flip rate.
5. Moving the related control stick, LED will automatically jump to the set rate display of the specific stick function. For example, moving the aileron stick, LED1 to LED5 will display aileron set rate. Moving elevator stick, LED to LED5 will display elevator set rate.

設定說明

1. 進入設定後STATUS的燈號閃爍一次。
2. 副翼及升降滾轉速率可以分開調整。
3. 撥動副翼搖桿會顯示副翼滾轉速率之LED燈號，燈號越多表示滾轉越快，再次撥動副翼搖桿可以增加或減少LED1-LED5亮燈數量，進而調整副翼滾轉速率，同理撥動升降舵搖桿會顯示升降滾轉速率之LED燈號，可以調整前後滾轉速率。
4. 升降滾轉速率會依副翼滾轉速度而調整，當升降滾轉速度和副翼滾轉速度相差20%以上，3GX會自動調整與限制在誤差範圍內，所以建議先調整副翼滾轉速率，再調整升降滾轉速率。
5. 動相關搖桿LED會自動跳至該搖桿設定值，例如動副翼搖桿，LED1-5會顯示副翼設定值。動升降搖桿，LED1-5會顯示升降設定值。

Move aileron stick to adjust aileron roll rate
撥動副翼搖桿調整副翼滾轉速率



STATUS Single flash
STATUS閃爍一次

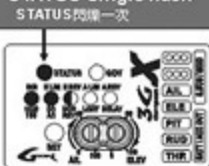

Move elevator stick to adjust elevator flip rate
撥動升降搖桿調整升降滾轉速率



STATUS Single flash
STATUS閃爍一次



2. ELEVATOR END POINT SETTING 升降舵行程極限設定

Setting Instruction

1. Before entering elevator and aileron limit setting, please switch the transmitter to throttle hold mode and push the throttle down to 0 position to avoid mechanical interference due to excess travel range.
2. After entering setting mode, STATUS LED flashes twice
3. After entering setting mode, elevator may deviate as much as 8 degrees plus compensating rate either forward or back. Moving elevator stick can adjust servo travel limit. For example, if LED shows 50%, total elevator travel range is $8+0.5 \times 8 = 12$ degrees.
4. Generally 70% is suitable for most helicopter frame. If recommended value is not used, please adjust setting until maximum is reached without mechanical binding.

設定說明

1. 進入升降舵與副翼行程極限設定前，請先將遙控器切換在熄火模式，並將油門搖桿設在0度的位置，避免行程過大時造成結構干涉。
2. 進入設定後STATUS的燈號閃爍兩次。
3. 進入後升降舵會偏至8度+外環值，有可能偏前或偏後，搖動升降舵搖桿可以調整伺服機行程極限。例如LED顯示設定為50%，升降舵行程總行程約為 $8+0.5 \times 8 = 12$ 度。
4. 一般而言70%可以適用於大部分的直升機機體，如果不使用建議值，請設定至機械結構不至干涉之極限值。

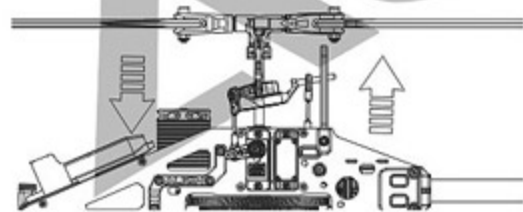

Move elevator stick to adjust elevator travel limit
撥動升降搖桿調整升降舵行程極限值



STATUS Double flash
STATUS閃爍兩次

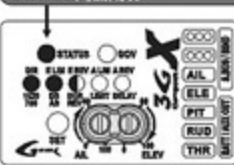

3. AILERON END POINT SETTING 副翼行程極限設定

Setting Instruction

1. After entering setting mode, STATUS LED flashes 3 times.
2. After entering setting mode, aileron may deviate as much as 8 degrees plus compensating rate either forward or back. Moving aileron stick can adjust servo travel limit. For example, if LED shows 50%, total elevator travel range is $8+0.5 \times 8 = 12$ degrees.
3. Generally 70% is suitable for most helicopter frame. If recommended value is not used, please adjust setting until maximum is reached without mechanical binding.

設定說明

1. 進入設定後STATUS的燈號閃爍三次。
2. 進入後副翼會偏至8度+外環值，有可能偏左或偏右，撥動副翼搖桿可以調整副翼行程極限值。例如LED顯示設定為50%，總舵量約為 $8+0.5 \times 8 = 12$ 度。
3. 一般而言70%可以適用於大部分的直升機機體，如果不使用建議值，請設定至機械結構不至干涉之極限值。

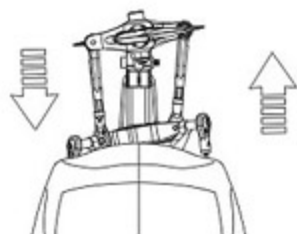

Move aileron stick to adjust aileron travel limit.
撥動副翼搖桿調整副翼行程極限值

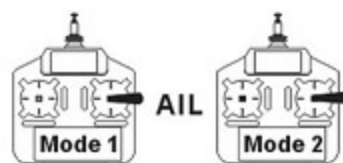

STATUS Flash in group of 3
STATUS閃爍三次

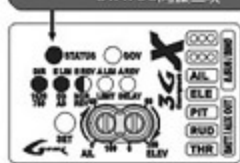

4. SWASHPLATE DAMPENING SETTING 十字盤柔化設定

Setting Instruction

1. After entering setting mode, STATUS LED flashes 4 times.
2. Move the aileron stick to adjust cyclic pitch dampening rate; the more LED lights up, the more dampening effect. Please note aileron and elevator dampening cannot be adjusted separately. Moving aileron stick is for adjusting cyclic pitch dampening rate, but moving elevator stick is for adjusting collective pitch dampening rate, NOT elevator dampening rate.
3. The more dampening effect, the smoother helicopter flies, but feels less direct. The rate of dampening should be adjusted to suit pilot's preferences.

設定說明

1. 進入設定後STATUS的燈號閃爍四次。
2. 撥動副翼搖桿可以調整循環螺距柔化程度，LED亮燈越多，柔化越多，但請注意副翼及升降柔化不可分開調整，所以撥動副翼搖桿為調整循環螺距柔化，但撥動升降舵搖桿是調整集體螺距柔化程度，而非升降舵柔化程度。
3. 柔化程度越多，機體飛行越平順，但越不直接，柔化程度可以個人不同手感調整。

Move aileron stick to adjust cyclic pitch dampening
撥動副翼搖桿調整循環螺距柔化值

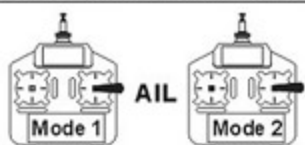

STATUS Flash in group of 4
STATUS閃爍四次

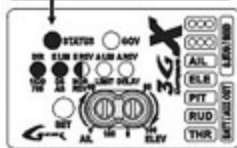

Move elevator stick to adjust collective pitch dampening
撥動升降搖桿調整集體螺距柔化值



STATUS Flash in group of 4
STATUS閃爍四次

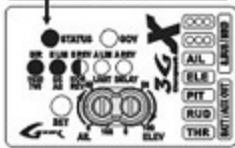

5. SWASHPLATE ACCELERATE SETTING 十字盤加速設定

Setting Instruction:

1. After entering setting mode, STATUS LED flashes 5 times.
2. Move the aileron stick to adjust cyclic pitch acceleration rate; the more LED lights up, the more acceleration effect. Please note aileron and elevator acceleration cannot be adjusted separately. Moving aileron stick is for adjusting cyclic pitch acceleration rate, but moving elevator stick is for adjusting collective pitch acceleration rate, NOT elevator acceleration rate.
3. When cyclic pitch acceleration is active, hovering point fixation ability may be reduced. Beginners or F3C pilots should minimize cyclic pitch acceleration rate value, or set it to zero.

設定說明

1. 進入設定後STATUS的燈號閃爍五次。
2. 撥動副翼搖桿可以調整循環螺距加速程度，亮燈越多，加速越多，但請注意副翼及升降加速是不可分開調整，所以撥動副翼搖桿為調整循環螺距加速，但撥動升降舵搖桿是調整集體螺距加速程度，而非升降舵加速程度。
3. 開啟循環螺距加速，會造成停旋時定點性較差，初學者或F3C飛行者請將循環螺距加速設定值降低，或設定為0。



Setting swashplate acceleration may increase the burst amp draw of servos. Therefore, BEC output capability should be confirmed to handle burst current when setting collective pitch acceleration, otherwise insufficient current supply may result in flight accidents. We recommend direct power supply if acceleration is higher than 50%.

設定十字盤加速會造成伺服機瞬間耗電量較高，所以請注意如果設定集體螺距加速，必須留意BEC是否可提供足夠的瞬間電流，否則有可能造成伺服器瞬間供電不足，而造成飛行事故，所以直接供電才建議可調整至50%以上的設定值。

Move aileron stick to adjust cyclic pitch acceleration
撥動副翼搖桿調整螺距循環加速值



STATUS Flash in group of 5
STATUS閃爍五次



Move elevator stick to adjust collective pitch acceleration
撥動升降搖桿調整集體螺距加速值



STATUS Flash in group of 5
STATUS閃爍五次

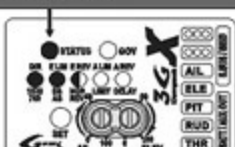

RUDDER GYRO SETUP 尾舵陀螺儀設定

After the system reboots, part of flybarless setup is completed. Now the rudder gyro needs to setup. Push and hold the SET button for 2 seconds to enter the rudder gyro setup mode.

If your transmitter has the following settings, please disable it or set the value to zero.

完成開機後Flybarless部分已設定完成，接著要設定尾舵陀螺儀，於待機狀態下持按"SET"鍵2秒進入尾舵陀螺儀設定。

如果您的遙控器有下列功能時，請設定為關閉(OFF)或數值設定為零。

- ATS
- Pilot authority mixing
- Throttle to rudder mixing
- Rudder to gyro mixing
- Pitch to rudder mixing
- Revolution mixing



3GX Flybarless rudder gyro has the factory setting of 1520 μ s and DS digital servo. Double check your servospec and change the gyro setting as needed to avoid damages to the servo.

3GX Flybarless 尾舵陀螺儀出廠設定值為：1520 μ s寬頻與DS數位伺服器模式，安裝時請確認您的伺服器規格，避免設定值不同而造成伺服器損壞。

1. 1520 μ S (STANDARD) OR 760 μ S (NARROW BAND) SERVO FRAME RATE SETUP

1520 μ s(標準)或760 μ s(窄頻)伺服器設定

3GX Flybarless system is compatible with both the 760 μ s narrow frame rate servos (such as Futaba S9256, S9251, BLS251), as well as the standard 1520 μ s frame rate servos (most others). Proper frame rate must be selected based on your servo's specifications.

To enter the setup mode: Press and hold the SET button for 2 seconds until STATUS LED flashes. The 1520/760 LED will light up indicating servo frame rate setup mode. Push the transmitter rudder stick left or right to select the frame rate. For example, if rudder is pushed to the left (or right) and STATUS LED turns green, the frame rate is set to 1520 μ s. To set it to 760 μ s, the rudder stick need to be pushed from the center to the opposing end 3 times for the STATUS LED to turn red, indicating frame rate set to 760 μ s.

3GX Flybarless panel: Each setting value is labeled on the 3GX flybarless control unit with either green or red lettering, which corresponds to the STATUS LED color. Subsequent setup mode is entered by a single press of the SET button. Setup mode will exit if no activity is detected in 10 seconds.

3GX Flybarless 相容兩種波寬控制系統，若您使用的伺服器屬於760 μ s 系統（如 Futaba S9256、S9251、BLS251），則必須將3GX Flybarless 設定於760 的模式，其他未標示760 μ s 規格的伺服器，一般皆為1520 μ s 系統，須設定為1520 的模式。

進入功能設定模式：持按面板上的“SET”設定鍵約2秒，此時“STATUS”狀態指示燈會開始閃爍，且“1520/760”的功能設定指示燈會亮起，表示進入標準／窄頻伺服器選項，利用遙控器方向舵搖桿的左右方向來選擇設定值，例如方向舵搖桿往左（或右）時，“STATUS”指示燈為綠色，表示設定值為1520 μ s 系統；若要設定為窄頻760 μ s 系統時，必須將搖桿由中立點往相反方向連續撥動3次，使“STATUS”指示燈亮紅色，才會進入760 μ s 系統。

3GX Flybarless 的面板：標籤上已使用綠／紅色的字體提示“STATUS”燈色所代表的設定值。設定完成後按“SET”鍵一次可進入下一個設定，或是10秒內不做任何設定，系統會自動離開設定模式。

Green LED : 1520 μ s standard band
Red LED : 760 μ s narrow band
綠燈：1520 μ s 寬頻伺服器
紅燈：760 μ s 窄頻伺服器

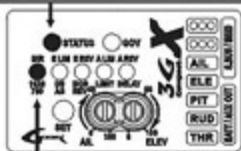

Standard/Narrow band mode
寬頻/窄頻模式

Select by moving the rudder stick left and right
左右撥動方向舵選擇



2. DS (DIGITAL) / AS (ANALOG) SERVO SELECTION DS數位/AS類比伺服器選擇

There is a direct correlation between servos' speed to gyro's performance. Faster servos are able to execute commands from the gyro at faster and higher precision. Due to the high performance gyro sensors used in the 3GX flybarless system, premium high speed digital rudder servos are mandatory for optimal tail performance.

Setup method : Press and hold the SET button for 2 seconds to enter the setup mode, then press the SET button to select DS/AS setup mode, as indicated by the lighting of DS/AS LED. Using the transmitter's rudder stick, select either digital servo DS mode (STATUS LED is green), or analog servo AS mode (STATUS LED is red).

伺服器動作速度與陀螺儀的性能，伺服器動作愈快，就能立即反應陀螺儀送出的指令，發揮快速精準的效能；由於3GX Flybarless 具有相當快速的反應時間與靈敏度，所以建議您搭配高速型數位伺服器，以獲得最佳效能。

設定方式：持按“SET”鍵2秒進入功能設定模式，再按“SET”鍵選擇DS/AS選項，（DS/AS指示燈亮起），利用方向舵搖桿選擇數位DS（STATUS為綠燈）或類比AS（STATUS為紅燈）伺服器。

Green LED : DS digital servo
Red LED : AS analog servo
綠燈：DS數位伺服器
紅燈：AS類比伺服器

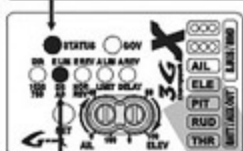

digital / analog mode
數位/類比模式



Using an analog servo in DS mode will cause damages to the servo.

在DS模式下連接“AS類比伺服器”將導致伺服器燒毀。

Select by moving the rudder stick left and right
左右撥動方向舵選擇



3. RUDDER SERVO DIRECTION CHECK AND LINK ADJUSTMENT 檢查尾舵伺服器正逆轉方向與調整選擇

Move the transmitter rudder stick left/right, and check for the correct direction of the rudder servo. If needed, servo reverse is done from the transmitter's REV (reverse) function.

For tail pitch adjustment, center the rudder servo by either setting the 3GX flybarless to normal rate mode (non-heading lock), or press and hold the SET button for 2 seconds. With the rudder servo centered and servo horn at 90 degrees, adjust the linkage length until tail pitch slider is centered on the tail output shaft as shown in diagram.

左右撥動尾舵搖桿，確認尾舵伺服器移動的方向是否正確，若正確請更改遙控器上的尾舵伺服器正逆轉方向。

將3GX Flybarless 切換成非鎖定模式或持按“SET”鍵2秒，使尾舵伺服器保持在中立點的位置上，調整伺服舵片，盡可能使尾舵連桿與伺服擺臂呈90度，接著調整連桿長度使尾Pitch 控制組置中。

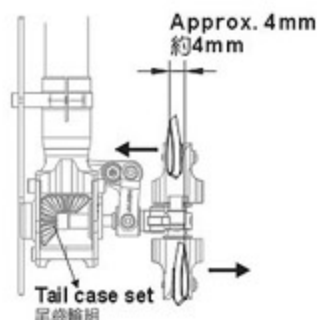
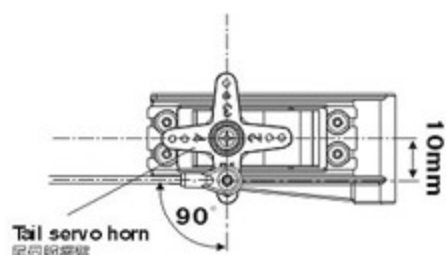

4. GYRO NOR/REV SETTING NOR/REV陀螺儀正反向開關設定

Lift up the helicopter by hand, and turn it to the left (yaw). Check if the rudder servo is applying correct compensation to the right. If reversed, set the NOR/REV setting as follow.

Setup method : Press and hold the SET button for 2 seconds to enter the setup mode, then press the SET button to select NOR/REV setup mode, as indicated by the lighting of NOR/REV LED. Using the transmitter's rudder stick, select either NOR (STATUS LED is green), or REV (STATUS LED is red).

提起直昇機，將機頭往左擺動，若尾舵伺服器的擺動方向與遙控器的方向舵搖桿打右舵同方向時，表示陀螺儀的動作方向設定正確，若不正確時請更改正反向設定。

設定方式：持按“SET”鍵2秒進入功能設定模式，選擇NOR/REV選項，以方向舵選擇NOR（STATUS為綠燈）或REV（STATUS為紅燈）。

Green LED : normal direction
Red LED : reverse direction
綠燈 : NOR正向
紅燈 : REV反向

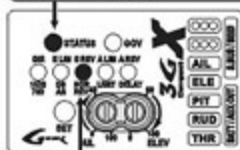

gyroscope direction settings
陀螺儀正反向設定

Select by moving the rudder stick left and right
左右撥動方向舵選擇

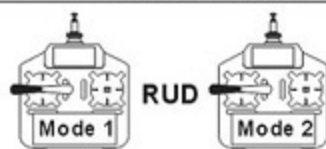

5. LIMIT rudder servo endpoint setting

LIMIT 尾舵伺服器行程量調整

Press and hold the SET button for 2 seconds to enter the setup mode, then press the SET button repeatedly to select LIMIT setup mode, as indicated by the lighting of LIMIT LED. Push the transmitter rudder stick left until tail pitch slider reaches the end, then center the rudder stick and wait 2 seconds for the STATUS LED to flash red. Then push the rudder stick right until tail pitch slider reaches the end, then center the rudder stick and wait 2 seconds for the STATUS LED to flash red. This completes the left and right endpoint limit adjustment of servo travel. Insufficient servo travel will degrade helicopter performance, while excessive travel will cause binding and damage rudder servo.

持按“SET”鍵2秒進入功能設定模式，此時尾舵伺服器會保持在中立點的位置上，選擇LIMIT選項，接著將方向舵搖桿慢慢的往左移動，使尾控制組達到該側的大行程限度後，將搖桿回歸中立點不動，待2秒後“STATUS”指示燈會亮紅燈閃爍，表示左側行程量已記憶；接著將尾舵搖桿向右移動至控制組最大行程限度後，再將搖桿回歸中立點不動，待2秒後“STATUS”指示燈亮紅燈閃爍，即完成左右行程量設定，行程量不足時會影響陀螺儀與直昇機的性能，行程量過大易造成伺服器損壞。

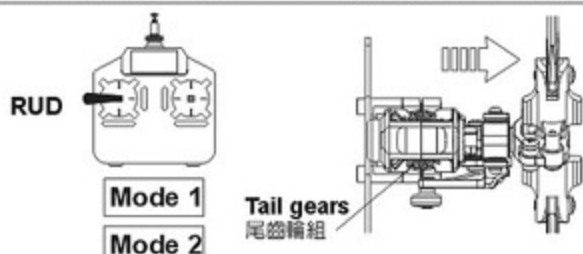

Push the transmitter rudder stick left until tail pitch slider reaches the end, then center the rudder stick and wait 2 seconds for the STATUS LED to flash red. This completes the rudder endpoint limit adjustment for the left side.

將方向舵慢慢往左撥動，使控制組達到左舵最大行程限度後，將搖桿回歸中立點不動，待2秒後“STATUS”紅燈閃爍表示左舵行程記憶量完成。

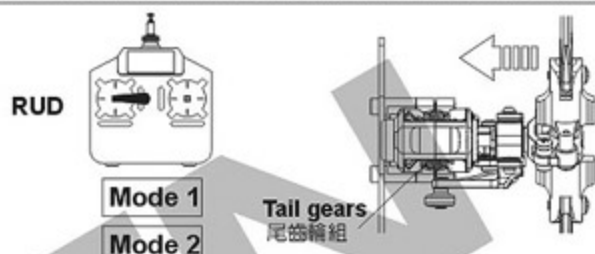

Push the rudder stick right until tail pitch slider reaches the end, then center the rudder stick and wait 2 seconds for the STATUS LED to flash red. This completes the rudder endpoint limit adjustment for the right side.

將方向舵慢慢往右撥動，使控制組達到右舵最大行程限度後，將搖桿回歸中立點不動，待2秒後“STATUS”指示燈表示右舵行程記憶量完成。

Flashing red LED indicates settings have been registered
紅燈閃爍時表示記憶完成

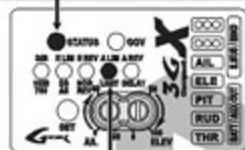

Endpoint limit settings
行程量設定



Rudder travel limit setting lower than 50% will not be registered. Mechanical fix (moving link ball closer to center of servo horn) is needed for excessive servo travel when LIMIT function is below 50%.

尾舵行程量設定不可低於50%，否則3GX Flybarless將不予記憶，若發生行程量設定後，尾控制組仍會超過最大行程，請將尾舵伺服的球頭向內移動，避免行程不足影響陀螺儀性能。

6. HELICOPTER SIZE AND DELAY SETTINGS

直昇機模式與DELAY控制延遲量調整

This setting includes two functions :

(1) For small helicopters such as T-REX 250/450, set this setting to small helicopter (STATUS LED red). For larger helicopters such as T-REX 500/550/600/700/800 set this setting to large helicopter (STATUS LED green).

此設定結合兩項功能：

(1) 3GX Flybarless 支援小型/迷你型室內電直，請依照直昇機的類型選擇適合的模式，如：T-REX250/450請選擇小型/迷你型模式（設定時“STATUS”指示燈為紅色）；T-REX500/550/600/700/800請選中大型直昇機模式（設定時“STATUS”指示燈為綠色）。

Green LED: suitable for larger helicopters such as T-REX500/550/600/700/800

Red LED: suitable for smaller helicopter such as T-REX 250/450

綠燈：適用T-REX500/550/600/700/800大型直昇機

紅燈：適用T-REX250/450小型直昇機

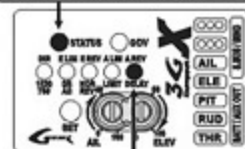

Helicopter size selection and servo delay settings
大小直昇機模式與延遲量設定

Select by moving the rudder stick left and right
左右撥動方向舵選擇



(2) The DELAY function is utilized when slower rudder servo causes tail hunting (wagging). This can be observed after a hovering pirouette comes to a stop. If tail hunting occurs, gradually increase DELAY value to eliminate it. For best performance, DELAY value should be kept as low as possible without tail hunting.

Setup method :

Press and hold the SET button for 2 seconds to enter the setup mode, then press the SET button to select DELAY setup mode, as indicated by the lighting of DELAY LED. The choice of small or large helicopter is done by moving the transmitter rudder stick left or right while observing the color of the STATUS LED. For small helicopters STATUS LED will be red, and large helicopter will be green. The amount of servo delay is set by how far you push the rudder stick, followed by pushing the SET button.

(2) 使用速度較慢的尾舵伺服器較容易產生追蹤現象，當直昇機停懸時，打方向舵使直昇機快速自轉，當方向舵回到中立點使直昇機停止自轉時，此時若發生追蹤現象，請增加控制延遲的設定量，一般而言在不產生追蹤現象的原則下控制延遲的設定量愈小愈好，否則尾舵的動作會變得遲緩。

設定方式： 持按“SET”鍵2秒進入功能設定模式，選擇至DELAY選項，以方向舵搖桿選擇小型/迷你型電道，如：T-REX 250/450 (STATUS為紅燈)，或中大型直昇機如T-REX500/550/600/700/800 (STATUS為綠燈)，若要同時設定DELAY控制量時，則利用方向舵搖桿的位置來設定，搖桿由中立點推至“DELAY”燈開始閃爍時為0%，推至最大行程時控制量為100%，將搖桿推至所需的延遲量時保持不動，並按下“SET”鍵確認，即可同時設定直昇機模式與延遲量。

Red LED for T-REX450
T-REX450 設定紅燈

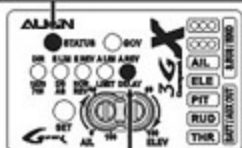

0% when DELAY LED begins flashing
DELAY燈開始閃爍時為0%

Red LED for T-REX450
T-REX450 設定為紅燈

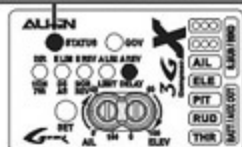

Gradually move the transmitter rudder stick until DELAY LED begins to flash, the delay value is 0% at this point.
輕推方向舵搖桿至“DELAY”燈開始閃爍時，延遲量為0%



Continue to move the rudder stick until desired delay value is needed, then press the SET button to register the setting. Maximum is 100% delay, with rudder stick pushed to the end.
方向舵推至最大行程時，延遲量為100%，將搖桿推至所需的延遲量，按下“SET”鍵確認



7. ANTI TORQUE COMPENSATION DIRECTION SETTING 反扭力補償正反向設定

To achieve consistent gyro gain on left and right, 3GX has built in anti-torque compensation function. User need to confirm if 3GX is mounted right side up or upside down.

Right side up : Installed with 3GX label facing up, anti-torque compensation set to positive (green STATUS LED).

Upside down : Installed with 3GX label facing down, anti-torque compensation set to negative (red STATUS LED).

為使陀螺儀左右感度一致，3GX內置反扭力補償功能，使用者需確認3GX為正裝或反裝。

正裝：安裝時3GX面板朝上，反扭力補償設為正向 (STATUS綠燈)。

反裝：安裝時3GX面板朝下，反扭力補償設為反向 (STATUS紅燈)。

Setup method : Press and hold the SET button for 2 seconds to enter setup mode, select until anti-torque compensation section, as indicated by lighting of all 5 setup mode LEDs. Using the rudder stick to select either positive anti-torque compensation (green STATUS LED) for right side up mounting, or negative anti-torque compensation (red STATUS LED) for upside down installation.

設定方式： 持按“SET”鍵2秒進入功能設定模式，選擇至反扭力補償設定項，此時5顆功能設定指示燈全亮，接著以方向舵搖桿選擇，當3GX正裝時，須設定為正向 (STATUS綠燈)；當3GX反裝時，須設定為反向 (STATUS紅燈)。

Green : Right side up mounting
Red : Upside down mounting
綠燈：3GX 正裝，反扭力補償正向
紅燈：3GX 反裝，反扭力補償反向



Anti Torque Compensation direction setting
反扭力補償正反向設定

Select by moving the rudder stick left and right
左右撥動方向舵選擇



8. SENSITIVITY ADJUSTMENT 感度調整

For radio with built in gyro gain settings, gain can be adjusted directly. For example, 50%-100% setting on the radio translates to 0% - 100% gain in the heading lock mode; 50%-0% setting on the radio translates to 0%-100% gain in the normal (non-heading) lock mode. Actual gain value differs amongst servos and helicopters. The goal is to find the maximum gain without tail hunting. This can only be done through actual flight tests.

The recommended starting point for transmitter's gyro gain setting should be 70~80% for hovering, 60~70% for idle-up.

Value should be tuned under actual flight conditions by increasing to the maximum gain without tail hunting.

一般具有陀螺儀感度設定功能的遙控器，可直接進入GYRO功能選項進行感度值的設定，設定值50%則陀螺儀的感度為0，設定值50%-100%，則陀螺儀感度值為鎖定狀態的0~100%；設定值50%-0%，則陀螺儀感度值為非鎖定狀態的0~100%。

感度值的大小會隨著伺服器與直昇機的不同而有所差異，一般而言，在不產生追蹤現象 (直昇機尾部出現左右搖擺的情況) 的前提下感度值愈高愈好，所以只能透過實際飛行的狀況來進行調整。

進入遙控器感度設定的選項，剛開始停懸時建議先設定在70~80%左右，Idle up飛行時設定在60~70%左右，之後再依實際飛行的狀態再行修正，如果沒有追蹤現象發生時可再調整高感度，若發生追蹤現象時，則調低感度。



注意

For radios (IE Futaba) using 0-100% as heading lock gain scales, the recommended gain setting is 30% to 35%.

For radio that uses the 50 -100% scale (such as JR and Hitec), the recommended gain setting is 70% to 75%.

鎖定感度值為0~100%的遙控器，如Futaba，建議設定在30~35%左右；鎖定感度值為50~100%的遙控器，如JR、HITEC，建議感度值設定在70~75%左右。

SPECIFICATIONS 產品規格

- | | | | |
|--|--|-------------------------|-----------------------------------|
| 1. Operating voltage range :
DC 3.5V~8.4V | 6. Operating temperature : -20°C~65°C | 1. 適用電壓：DC 3.5V~8.4V | 6. 操作溫度：-20°C~65°C |
| 2. Operating current consumption :
<80mA @ 4.8V | 7. Operating humidity : 0%~95% | 2. 消耗電流：<80mA @ 4.8V | 7. 操作溫度：0%~95% |
| 3. Rotational detection rate : ±300°/sec | 8. Dimension/Weight :
36.5x25.2x15.6mm/ 11g | 3. 偵測側滾及前滾角速度：±300°/sec | 8. 尺寸/重量：
36.5x25.2x15.6mm/11g |
| 4. Rudder yaw detection rate : ±600°/sec | 9. RoHS certification stamp | 4. 偵測尾舵角速度：±600°/sec | 9. 符合RoHS環保規章 |
| 5. Sensor resolution : 12bit | | 5. 感應器解析度：12bit(12位元) | |

	Swashplate Settings 十字盤設定	3GX throttle calibration 3GX油門行程校正	Rudder Settings 尾舵設定	Flight Mode Setting 飛行特性設定
Enter Setup Mode 進入方式	Turn on transmitter, press/hold SET, power on heli, release SET before LEDs stop scrolling. 先開遙控器，按SET鍵，開機體電源，跑馬燈跑完之前放開按鍵。	Turn on TX, lower throttle all the way down, press/hold SET, power on heli, release SET after LEDs stop scrolling. 先開遙控器，將遙控器油門至於最低點，按SET鍵，開機體電源，跑馬燈跑完後放開按鍵。	With 3GX powered up, press SET for about one second. 在3GX運作狀態中，按SET鍵約一秒。	With 3GX powered up, push the rudder stick left or right, and hold the SET button for about one second. 在3GX運作狀態中將尾舵扳至左邊或右邊，接著按SET鍵約一秒。
Setting 1 設定一	LED 燈號 Setting 程序	LED1 Lit LED1 亮	LED1 lit LED1 亮	STATUS flashes green 1 once STATUS閃綠燈一下
	Setup Method 設定方式	Mechanical Travel and Neutral point setting 機械行程與中立點設定 Setup swashplate movement on TX, and set the right aileron cyclic pitch to 8 degrees. The ELE mixing ratio in SWASH menu can be set to the same value as AIL. 設定遙控器十字盤動作，並將右副翼循環螺距設為8度，升降舵swash比率與副翼比率相同即可，設定完成後旋翼角度歸零。	3GX throttle calibration 3GX油門行程校正 Push throttle open fully to complete setup, indicated by flashing of LED1-5, and then enter normal operation condition. 將油門位置推至全開，設定完成，LED1-LED5閃爍，後進入系統正常狀況。	Wide/narrow servo band setting 寬/窄頻伺服設定 Set servo wide/narrow band using rudder stick. Green LED for standard wide band servos. For narrow band servo, LED will be orange until rudder stick is pushed 3 times to confirm setting and status LED will turn to red. 由尾舵搖桿設定寬/窄頻伺服機。STATUS綠燈為一般伺服機時，必須注意設定窄頻伺服機必須，STATUS會先亮橘燈，搖三次後才會變紅燈。
Setting 2 設定二	LED 燈號 Setting 程序	LED2 Lit LED2 亮	LED2 lit LED2 亮	STATUS flashes green 2 twice STATUS閃綠燈兩下
	Setup Method 設定方式	Elevator Travel Limit Setting 升降舵行程設定 Push elevator stick forward to limit, and release. 將遙控器升降舵搖桿往前推至最前位置，然後放開。	Digital/Analog Servo Selection 數位/類比伺服選擇 Move rudder stick to select digital/analog servo. Green STATUS indicates digital servo, red indicates analog. 由尾舵搖桿設定數位/類比伺服機，STATUS綠燈為數位伺服器，紅燈為類比伺服機。	Elevator travel limit setting 升降舵行程極限設定 While in this mode, elevator may deviate forward/backward by as much as 8 degrees + offset percentage. For example, LED displays 50% settings, total elevator travel will be 8+0.5*8=12 degrees. Set to a value with no mechanical binding at extreme end or keep default value at 70%. 進入後升降舵會偏至8度+外環值，有可能偏前或偏後，例如LED顯示設定為50%，總舵量為8+0.5*8=12度，設定至機械不至干涉之極限值或保留預設70%。
Setting 3 設定三	LED 燈號 Setting 程序	LED3 Lit LED3 亮	LED3 lit LED3 亮	STATUS flashes green 3 twice STATUS閃綠燈三下
	Setup Method 設定方式	Elevator gyro setting 升降舵陀螺正反設定 Tilt heli forward and back while observing gyro correction direction. If reversed, move elevator stick until STATUS LED changes color to reverse gyro direction. 前後搖動機身，觀看陀螺修正方向，如果錯誤，搖動升降搖桿，改變STATUSLED燈號以改變陀螺修正方向。	Rudder Gyro NOR/REV Setting 舵螺正反設定 Yaw the heli left/right while observing gyro correction direction. If reversed, move rudder stick to change direction. 左右搖動機身，查看尾舵修正方向，如果反向，搖動尾舵搖桿，改變修正方向。	Aileron travel limit setting 副翼行程極限設定 While in this mode, aileron may deviate left/right by as much as 8 degrees + offset percentage. For example, LED displays 50% settings, total aileron travel will be 8+0.5*8=12 degrees. Set to a value with no mechanical binding at extreme end or keep default value at 70%. 進入後副翼會偏至8度+外環值，有可能偏左或偏右，例如LED顯示設定為50%，總舵量為8+0.5*8=12度，設定至機械不至干涉之極限值或保留預設70%。
Setting 4 設定四	LED 燈號 Setting 程序	LED4 Lit LED4 亮	LED4 lit LED4 亮	STATUS flashes green 4 once STATUS閃綠燈四下
	Setup Method 設定方式	Aileron Travel Limit Setting 副翼行程設定 Push aileron stick to extreme right, and release. 將副翼搖桿向右推至極限，然後將搖桿置中。	Rudder Servo Travel 尾向服務行程 Move rudder stick to left/right until rudder at extreme end point, wait until STATUS change from green to red. 移動尾舵搖桿，移動尾舵左右行程至極限位置，稍候等待，STATUS燈由綠轉紅時完成該項的設定。	Swashplate Dampening Setting 十字盤柔化設定 Move elevator stick to adjust collective pitch dampening level. Move aileron stick to adjust cyclic pitch dampening. More LED's indicates more dampening. 搖動升降舵搖桿可以調整集體螺距柔化程度，搖動副翼搖桿可以調整循環螺距柔化程度，亮燈越多，柔化越多。
Setting 5 設定五	LED 燈號 Setting 程序	LED5 Lit LED5 亮	LED5 lit LED5 亮	STATUS flashes green 5 once STATUS閃綠燈五下
	Setup Method 設定方式	Aileron gyro setting 副翼陀螺正反設定 Tilt heli left and right while observing gyro correction direction. If reversed, move aileron stick until STATUS LED changes color to reverse gyro direction. 左右搖動機身，觀看陀螺修正方向，如果錯誤，搖動副翼搖桿，改變STATUS LED燈號以改變陀螺修正方向。	Heli Size and Delay Value 直昇機模式與延遲量 Move rudder stick to change STATUS color, green STATUS for large heli more, red STATUS for small heli mode. Moving rudder stick to any one side to set delay. The amount of delay is determined by distance from center and keeps the position. Press EXIT to set. 以尾舵搖桿設定STATUS燈號，綠燈為大直昇機模式，紅燈為小直昇機模式，搖桿撥至任一邊並保持位置才跳出此模式為設定延遲值，搖桿偏量越多，接著按跳出，延遲量越多。	Swashplate bump (acceleration) Setting 十字盤加速設定 Move elevator stick to adjust collective pitch acceleration level. Move aileron stick to adjust cyclic pitch acceleration level. More LED's indicates more acceleration. If acceleration level exceeds 50%, check the BEC to ensure it can supply enough current to servos. Dedicated receiver battery is recommended for acceleration higher than 50%. 撥動升降舵搖桿可以調整集體螺距加速程度，撥動副翼搖桿可以調整循環螺距加速程度，亮燈越多，加速越多。注意集體螺距加速超過50%，必須注意BEC是否可供應足夠電流，有可能造成伺服機瞬間供電不足，直接供電才建議可調整至50%以上。
Setting 6 設定六	LED 燈號 Setting 程序	LED 1-5 all lit up LED1-5全亮	LED 1-5 all lit up LED1-5全亮	
	Setup Method 設定方式		Gyro install reverse setting 陀螺安裝正反設定 Use rudder stick to set gyro install position. Green STATUS is normal, red STATUS is install upside down. 用尾舵搖桿，綠燈為正裝，反之紅燈為倒裝。	
Warnings 注意事項	After completing setting of 8 degrees SWASH, do not make further adjustments. If adjustment to helicopter's roll rate is needed, the adjustment must be made in the roll rate under flight mode's cyclic pitch section. 設定完8度後的SWASH值，不可以再調整，如果要調整直昇機滾轉速率，必須使用飛行特性設定功能的滾轉速率調整進行設定。			1. Flashing LED indicates 10%; fully lit LED indicates 20%. For example, LED1 and LED2 are fully lit, while LED3 is flashing, this is translated to 2*20+10=50%. LED閃爍為10%，全亮為20%，例如LED1-LED2全亮，LED3閃爍，設定值為2*20+10=50%。 2. Move the stick to display the stick function's setting value. For example, moving aileron stick will result in LED1-LED5 displaying aileron's setting value. 撥動副翼搖桿LED會自動跳至該搖桿設定值，例如副翼搖桿，LED1-5會顯示副翼設定值。

RCM-BL460MX MOTOR 無刷馬達

This new Brushless motor developed by the ALIGN POWER R&D TEAM, is packed with the latest, cutting edge technology available today. It features exceptional levels of high-torque power. The 460MX utilizes an 6-pole outrunner stator-rotor and unrivaled Ndfb extra strong magnets that traditional magnets cannot compare to. Also included is a high temperature, wear-resisting, low friction, double ZZ high efficiency bearing. The 460MX will be the most revolutionary motor operating on low current amperage, and delivering high torque to RC models.

由亞拓動力團隊獨家研發出新款的無刷馬達，具有超高扭力特色，採用9槽矽鋼片、6極外轉子以及傳統磁鐵無法比擬的釹鐵硼超強磁鐵，搭配高溫耐用的雙ZZ超高效能精密軸承設計，電流低、扭力強，將是下一波動力革命中的最具代表性的一顆星。

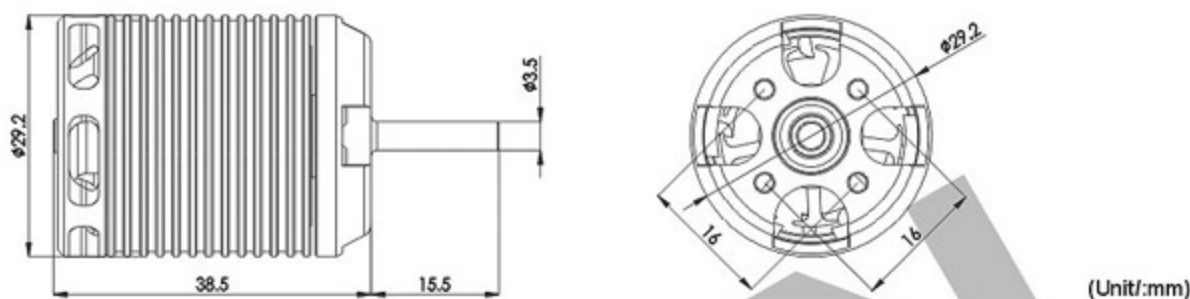
**SPECIFICATION 尺寸規格：**

KV	KV值	1800KV(RPM/V)	Input voltage	輸入電壓	6S
Stator Arms	矽鋼片槽數	9	Magnet Poles	磁鐵極數	6
Max continuous current	最大持續電流	30A	Max instantaneous current	最大瞬間電流	45A(5sec)
Max continuous power	最大持續功率	650W	Max instantaneous power	最大瞬間功率	970W(5sec)
Dimension	尺寸	Shaft ϕ 3.5x29.2x54mm	Weight	重量	Approx. 87g

PRODUCT FEATURES 產品特色

- 5-6V step-less adjustable BEC output allowing custom voltage setting to match servo specification.
 - BEC output utilizing switching power system, suitable for 7.4-22.2V (2S-6S) Li battery, with continuous current rating of 3A, and burst rating of 5A.
 - Three programmable throttle speed settings to support quick throttle response.
 - Include soft start and governor mode.
 - Small and compact PCB design for lightweight and simple installation.
 - Large heat sink for optimum thermal performance.
 - Highly compatible to work with 98% of all brushless motors currently on the market.
 - Ultra-smooth motor start designed to run with all kinds of brushless motors.
 - The power inlet utilizes a Japanese made "Low ESR" capacitor in order to provide stable power source.
 - The throttle has more than 200 step resolution that provides great throttle response and control.
- 5~6伏特無段可調式BEC輸出，可依伺服器規格與所需的特性自行設定電壓。
 - BEC輸入端採用交換式電源設計，適用7.4~22.2V(2S~6S)鋰電，持續耐電流3A，瞬間5A。
 - 三段可程式油門反應速度，使動力的反應隨傳隨到。
 - 具緩啟動及Governor Mode定速功能。
 - 體積小，窄型設計，安裝於機身容易。
 - 有散熱片設計，可延長電變壽命。
 - 超高相容性，可對應市面上98%無刷馬達。
 - 絕佳起步設計，無論國產、進口、內轉、外轉無刷馬達皆起步順暢。
 - 電池電源端採用日製Low ESR低阻抗電解電容，大幅提高電源之穩定性。
 - 油門達200段以上解析度，無格數之油門感覺。

WIRING ILLUSTRATION 接線示意圖



SPECIFICATION 尺寸規格：

Model 型號	Continuous Current 持續	Peak Current 瞬間	BEC Output BEC輸出	Dimension 尺寸	Weight 重量
RCE-BL45X	45A	60A	Output voltage: 5-6V step-less adjustment Continuous current 3A; Burst current 6A 輸出電壓: 5~6V無段可調式 承受電流: 持續3A、瞬間6A	58x29.3x21mm	47g

1. Good temperature situation for working at the maximum current
2. Supporting motor types: 2~10 pole in/outrunner brushless motors.
3. Supporting maximum RPM: 2 pole → 190,000 rpm; 6 pole → 63,000 rpm.
4. Input voltage: 7.4V ~ 22.2V(2~6S Li-Po)

NOTE : 1. When setting to the Quick throttle response speed, the accelerative peak current will increase.

2. To minimize possible radio interference induced by switching power system, BEC should be installed at least 5cm away from the receiver. The use of 2.4G receiver is recommended.

1. 持續最大電流需在機體散熱良好情況下。
2. 支援馬達型式: 二極至十數極之內外轉子無刷馬達。
3. 支援最高轉速: 二極→190,000rpm; 六極→63,000rpm。
4. 輸入電壓: 7.4V-22.2V(2~6S Li-Po)

注意: 1. 設定為高油門反應速度時, 加速瞬間電流會有增大情形。

2. 內建 Switching BEC, 安裝時請與接收器保持至少5cm以上的距離以避免干擾接收器(建議使用較穩定的2.4G系統接收器)。

FUNCTIONS 產品功能

1. Brake Option - 3 settings that include Brake disabled/Soft brake/Hard brake.
2. Electronic Timing Option - 3 settings that include Low timing/Mid timing/High timing. Generally, 2 pole motors are recommended to use low timing, while 6 or more poles should use Mid timing. High timing gives more power at the expense of efficiency. Always check the current draw after changing the timing in order to prevent overloading of battery.
3. Battery Protection Option- 2 settings that include Li-ion, Li-poly High/Middle cutoff voltage protection. The default setting is high cutoff voltage protection. CPU will automatically determine cell number of input Lithium battery (2S~6S). This option will prevent over-discharge of the battery. The following reference is the guideline for setting the Battery Protection option.
 - 3-1 Li-ion/Li-poly High cutoff voltage protection-When the voltage of single cell drops to 3.2V, the first step of battery protection mode will be engaged by the ESC resulting in reduced power. The pilot should reduce the throttle and prepare landing. If the voltage of single cell drops to 3.0V, the second step of battery protection mode will be engaged resulting in power cutoff. (*Note 1) For 22.2V/6cells Lithium battery, the full charged voltage will be approximately 25.2V. According to this input voltage, CPU will determine that this is a 3cell battery.
First step protection: 3.2V x 6cell=19.2V
Second step protection: 3.0V x 6cell= 18V
When the voltage drops to 19.2V, the power will be reduced. When the voltage drops to 18V, the power will be cut off.
 - 3-2 Li-ion/Li-poly Middle cutoff voltage protection- This option is same as instruction 3-1, but when the voltage of single cell drops to 3.0V, the first step of battery protection will be engaged. When the voltage of single cell drops to 2.8V, the second step of battery protection will be engaged. (*Note 1)
Note 1: Second step of battery protection only works when Aircraft mode is setting to the option 4-1.
Note: this option is only suitable for a fully charged battery pack in good working condition.
4. Aircraft Option: 3 settings that include Normal Airplane / Helicopter 1 / Helicopter 2. Normal Airplane Mode is used for general airplanes and gliders. When flying Helicopters, you can choose Helicopter 1 Mode, or Helicopter 2 Mode. Helicopter 1 Mode provides Soft Start feature. Helicopter 2 Mode provides Soft Start and Governor Mode.
5. Throttle response speed: 3 settings that include standard/ Medium/ Quick throttle response speed. The default setting is "quick speed". Use this option to adjust the setting according to flight character. For example, setting at Medium or Quick speed for 3D and powerful flight to make the power response more quickly, but note the accelerative peak current and power expense will increase.
6. BEC output voltage setting: 5-6V step-less adjustment. This option allows custom voltage setting. Default setting is 5.5V; please adjust the voltage according to the specification of the servo (speed and resistance). Prior to entering the setup mode, a voltmeter needs to be connected to the power inlet of the receiver (as illustration) to monitor the selected voltage. The voltage is set by varying the throttle stick position from low (5V) to high (6V).

The voltmeter needs to be connected to any un-use inlets "+" and "-" to measure the selected voltage.
將電壓表連接到任一未使用通道的"+"端及"-"端, 以量測所選擇的電壓。

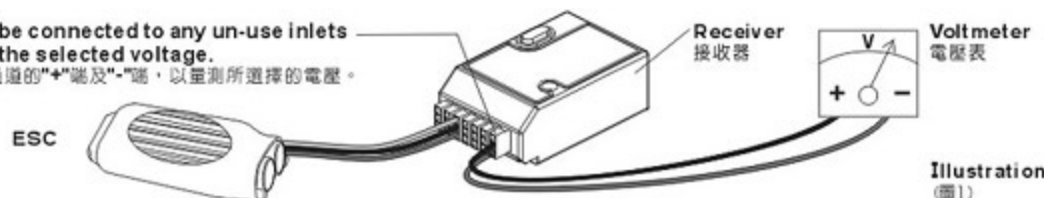

NOTE : Certain servos are designed to work with high voltage, while other servos are designed for lower voltage. To avoid damage to servos, please follow the servo's factory specification to determine the proper voltage setting.
注意: 部份伺服器不適合較高的電壓下操作, 請依原廠適用電壓規格設定, 避免造成伺服器燒毀。

- 7. Thermal Protection:** When the ESC temperature reaches 80° C for any reason, it will engage the battery protection circuit, reducing power to the ESC. We recommend mounting the ESC in a location with adequate air flow and ventilation.
- 8. Safe Power On Alarm:** When the operator turns on the ESC, it will automatically detect the transmitter signal. The ESC will emit a confirmation tone and enter normal operation mode if the throttle is set to the lowest position. If the throttle position is at full throttle, it will begin to enter Setup Mode. If the throttle is in any other position, the ESC will emit an alarm and not enter into user mode for safety precautions.
- 9. Aircraft Locator:** If the aircraft should land or crash in an unexpected location and become lost, the pilot can enable the Aircraft Locator Option. The aircraft locator option is engaged by turning off the transmitter. When the ESC does not receive a signal from the transmitter for 30 seconds, it will start to send an alarm to the motor. The sound of the alarm will aid the pilot to locate the aircraft. This option will not work with a PCM receiver that has SAVE function enabled, or with low noise resistant PPM receivers.

1. 煞車設定：三段選擇分為無煞車 / 軟性煞車 / 急煞車

2. 進角設定：三段選擇分為低進角 / 中進角 / 高進角

設定時機分為二檔以及六檔以上無碳刷馬達，二檔無碳刷馬達一般適用低進角，若希望馬達轉速提高，可將進角設定為中進角。六檔以上無碳刷馬達一般適用中進角，若希望馬達轉速提高，可將進角設定為高進角。然而進角之調整需要注意電流之變化，避免電池過載，影響電池及馬達壽命。

3. 電池保護電壓設定：二段選擇分為 Li-Ion、Li-Po 高截止電壓保護 / 中截止電壓保護

出廠設定為高截止電壓保護；此功能會自動判定所輸入電池的 cell 數 (2~6S)，並提供使用者對該電池之放電保護，以避免因放電電壓過低而造成電池損壞，以下為設定值之解說：

3-1 Li-Ion/Li-Po 高截止電壓保護：當電單 cell 壓降達 3.2V 時，電變會啟動第一階段保護，使動力間歇性中斷，此時使用者應將油門收小，準備降落；而當單 cell 電壓持續壓降達到 3.0V 時則會啟動第二階段保護，完全限制動力輸出 (註1：僅在 4-1 選項 "一般飛機模式" 下才會啟動第二階段保護)。

例：以一個使用 22.2V 6cell 電池之系統而言 22.2V 電池充電電壓約 25.2V，此輸入電壓 CPU 會自動判定為 6cell 電池。

第一階段保護：3.2Vx6cell=19.2V

第二階段保護：3.0Vx6cell=18V 當電壓降至 19.2V 時，動力會間歇性中斷，當壓降達到 18V 時則完全限制動力輸出。

3-2 Li-Ion/Li-Po 中截止電壓保護：同 3-1 功能說明，但單 cell 壓降達到 3.0V 時，會啟動第一階段保護，單 cell 壓降達到 2.8V 時啟動第二階段保護 (註1)。

注意：以上功能僅適用於充電電，且功能正常的電池。

4. 飛機模式設定：三段式選擇分為：一般飛機模式 / 直昇機模式 1 / 直昇機模式 2

使用於一般飛機或滑翔機時，請設定於一般飛機模式，使用於直昇機時可選擇直昇機模式 1：具有緩啟動功能，或直昇機模式 2：具有緩啟動及 Governor Mode 定速功能。

5. 油門反應速度設定：三段選擇分為標準 / 中速 / 快速

出廠設定值為 "快速" 油門反應速度，此功能提供使用者依所需之飛行特性來作適當的調整，例如 3D 飛機與劇烈的 3D 直昇機飛行時可設定為中速或快速，使動力反應更加快速、靈敏，但須注意提高油門反應速度時，加速瞬間電流與耗電量會有增大的情形。

6. BEC 輸出電壓設定：5~6V 無段調整

本功能提供使用者自行設定 BEC 輸出電壓，初始電壓為 5.5V，使用者可依伺服器的規格與所需的特性 (速度與扭力) 自行更改設定；進入此項設定前，請先將電壓連接到接收器的電源 端 (如圖 1)，用以監看所選擇的電壓，設定時以油門搖桿的位置來決定輸出電壓，油門搖桿最低為 5 伏特，最高為 6 伏特，之間的電壓值可移動搖桿的位置任意設定。

7. 溫度保護：當電變因不良之空氣對流或是過載輸出導致溫度上升達 80°C 時，電變會啟動溫度保護，而使動力間歇性中斷，建議將電變裝置在機艙內空氣對流之位置，並實際使用電流表監測 輸出電流，以達到電變之最佳效率。

8. 開機防塞動提醒功能：當使用者開啟電變電源時，系統會自動偵測發射機之設定，如果發射機油門未置於最低點，或未置於最高點準備進入設定模式，馬達將不會轉動，同時會有警示聲響提醒。

9. 尋機功能：當飛機降落在長草區無法以目視定位時，使用者可將發射機關閉，當電變無法接收來自接收機信號時，電變會於三十秒後使馬達發出警示聲響，以利定位。此功能不適用於設定了 SAVE 功能之 PCM 接收機，或抗雜訊低之 PPM 接收機。

SETUP MODE 設定模式

1. Setup mode: Make sure to connect the ESC to the throttle channel of the receiver. Please refer to the user manual of your radio system. The second step is to connect the 3 power-out signal pins to the brushless motor. Before you turn on the transmitter, please adjust the throttle stick to the maximum full throttle position. Proceed to connect the battery to the ESC. You will hear confirmation sounds as soon as you enter the SETUP MODE. Please refer to page 37 for details.

2. Throttle stick positions in Setup mode: Setup mode includes six settings: Brake, Electronic Timing, Battery Protection, Aircraft, Throttle Response Speed and BEC output voltage. Every setting has three options. Simply place the throttle stick in the highest, middle, and lowest positions for each setting. For example, first brake setting (Hard): move the stick to the highest position. Then timing setting (mid): move the throttle stick in the middle position.

1. 進入設定模式：將電變與接收器之油門 Channel 連接，不同之遙控系統請參閱您遙控系統之使用手冊，馬達之三條線亦與電變連接，將發射器之油門搖桿推到最高點，使之於全油門狀態，先開啟發射器電源，再將電源連接至電變，進入設定模式後，馬達將有設定模式之提示聲響。請參考第 37 頁程式化設定模式說明。

2. 設定模式中之動作：設定模式共含有六項設定，分別為煞車、馬達進角、電池保護、飛機模式、油門反應速度及 BEC 輸出電壓等設定，詳細內容請參考產品功能之解說。每一項設定中各含三段設定，各項設定以油門搖桿之上、中、下位置來決定其設定值。
例如：煞車設定時，油門搖桿撥至最高，則設定為急煞車，進入第二項進角設定時，油門搖桿撥至中間，則設定為中進角。

Mode 設定模式	Throttle position 油門搖桿	Low 低	Middle 中	High 高
Brake 煞車設定		● Brake disabled(1-1) 無煞車 (1-1)	Soft brake(1-2) 軟性煞車 (1-2)	Hard brake(1-3) 急煞車 (1-3)
Electronic Timing 進角設定		Low-timing(2-1) 低進角 (2-1)	● Mid-timing(2-2) 中進角 (2-2)	High-timing(2-3) 高進角 (2-3)
Battery Protection 電池保護電壓設定		● High cutoff voltage protection(3-1) 高截止電壓保護 (3-1)	Middle cutoff voltage protection(3-2) 中截止電壓保護 (3-2)	—
Aircraft 飛機模式設定		Normal Airplane/Glider(4-1) 一般飛機 / 滑翔機 (4-1)	● Helicopter 1 (Soft Start)(4-2) 直昇機模式 1 (緩啟動功能) (4-2)	Helicopter 2 (Soft Start+ Governor Mode)(4-3) 直昇機模式 2 (緩啟動+Governor Mode 定速功能) (4-3)
Throttle response speed 油門反應速度設定		Standard(5-1) 標準 (5-1)	Medium speed(5-2) 中速 (5-2)	● Quick speed(5-3) 快速 (5-3)
BEC output voltage BEC 輸出電壓設定		5.0V	● 5.5V	6.0V

Note: "●" default setting
註："●" 表示出廠設定值

Chart A
表 A

ESC START-UP INSTRUCTION 開機使用模式

1

Ensure the throttle stick is at the lowest position.
Switch on transmitter.
打開電源，油門搖桿置於最低點，準備進入使用操作模式



2

Connect battery power to ESC
變速器接上電源，馬達響音提示

Power on sound
開機確認音

Transmitter detected sound
系統偵測OK















3

Current Settings Indicator Beeps
升空使用模式響音提示

First mode sound (Brake)
Second mode sound (Timing)
Third mode sound (Battery protection)
Fourth mode sound (Aircraft)
Fifth mode sound (Throttle response speed)
No sound for BEC output voltage

第一種模式響音提示(煞車)
第二種模式響音提示(齒角)
第三種模式響音提示(電池保護)
第四種模式響音提示(飛機模式)
第五種模式響音提示(油門反應速度)
BEC輸出電壓不會以響音提示

CURRENT SETTINGS INDICATOR BEEPS EXPLANATION 開機模式設定響音提示說明

<p>First Beep Group Brake Status 第一個響音 煞車設定狀態提示</p> <ul style="list-style-type: none">  = Brake disabled = 無煞車  = Soft brake = 軟性煞車  = Hard brake = 急煞車 	<p>Second Beep Group Electronic Timing 第二個響音 齒角設定狀態提示</p> <ul style="list-style-type: none">  = Low timing (apply to 2 pole inrunner motors) = 低齒角 (適合2級內轉子馬達)  = Mid timing (apply to 6 pole in/out runner motors) = 中齒角 (適合6級內外轉子馬達)  = High timing (apply to high power output) = 高齒角 (適用於高功率輸出) <p>High timing big power/capase 高齒角模式有較大功率與耗電特性</p>	<p>Third Beep Group Battery protection Cutoff 第三個響音 電池保護設定狀態提示</p> <ul style="list-style-type: none">  = High cutoff voltage protection = 高截止電壓保護  = Middle cutoff voltage protection = 中截止電壓保護 	<p>Fourth Beep Group Aircraft Status 第四個響音 飛機模式設定狀態提示</p> <ul style="list-style-type: none">  = Normal airplane/Glider = 一般飛機/滑翔機  = Helicopter 1 (Soft start) = 直昇機模式1(緩啟動功能)  = Helicopter 2 (Soft start + Governor Mode) = 直昇機模式2(緩啟動功能+Governor Mode定速功能) 	<p>Fifth Beep Group Throttle Response 第五個響音 油門反應速度設定狀態提示</p> <ul style="list-style-type: none">  = Standard = 標準  = Medium speed = 中速  = Quick speed = 快速
--	--	--	--	--

INSTRUCTIONS ON AIRCRAFT MODE SETTINGS 飛機模式設定使用說明

Normal Airplane/Glider Mode (Option 4-1):

This option is applied to general airplanes and gliders.

Helicopter 1 Mode (Option 4-2):

This option provides a soft start feature and is applied to Helicopters for Normal, Idle Up 1, or Idle Up 2 modes.

Please note that the sensitivity of the gyro should be set lower when flying in Idle Up 1 or Idle Up 2 modes if tail hunting (wag) occurs due to higher rotor speed.

Helicopter 2 Mode (Option 4-3):

This option supports soft start as well as Governor Mode features and is applied to Helicopters for Idle Up 1 and Idle Up 2 modes (not suitable for Normal Flight Mode). When Governor Mode is in use, the throttle should be set between 75% and 85%. Again if tail wag occurs, lower the sensitivity of the gyro to eliminate the hunting effect. The Governor Mode may not work properly in cases of insufficient rotor speed (due to improper gear ratio), poor battery discharge capability, and improper setting of gyro sensitivity and the blade pitch, etc. Please make sure all the proper adjustments have been done when using Governor Mode.

一般飛機模式(選項4-1): 適用於一般飛機及滑翔機。

直昇機模式1(選項4-2): 具有緩啟動功能，適用於Normal、Idle1、Idle2等飛行模式，當切換至Idle1或Idle2模式，如有較高轉速造成陀螺儀有輕微的追蹤現象，此時應將陀螺儀的感度設定分別降低。

直昇機模式2(選項4-3): 具有緩啟動及Governor Mode定速功能，適用於Idle1、Idle2特技飛行模式(不適合Normal飛行模式下選用)，選擇定速功能時，油門應定速在75%~85%之間，如果飛行時發現有輕微的追蹤現象時，應降低陀螺儀的感度；由於轉速不足(齒比搭配不當)，電池效能不佳，陀螺儀感度設定不當，Pitch設定錯誤，皆會導致無法發揮定速的功能，甚至產生尾部偏擺的情形，所以選擇此模式時應針對相關條件進行確認。

SETUP MODE 程式化設定模式

Minimum 4 channel radio is required 四動以上標準發射器均可執行設定

1

Place the throttle stick to the highest position. Switch on transmitter.
打開電源，油門搖桿置於最高點準備進入程式化功能設定模式



2

Connect battery to ESC
變速器接上電源，馬達響音提示

Power on sound
開機確認音

Enter Setup Mode
進入設定模式

3

Throttle channel adjustment process, the highest position acknowledge sound.
油門校正程序最高點響音

4

Place the throttle stick to the lowest position. Position, the lowest position acknowledge sound.
油門搖桿置最低點響音

5

Use throttle stick to set preferred Brake Mode within the 5 tones. A confirmation sound will kick in when finish.
於5音節之音樂響音時以強制油門選擇設定，設定正確時將有連綿響音確認，結束時將有連續響音確認



6

Use throttle stick to set preferred Timing Mode within the 5 tones. (Refer to Chart A) A confirmation sound will kick in when finish.
於5音節之音樂響音時以強制油門選擇設定，設定正確時將有連綿響音確認，結束時將有連續響音確認



7

Use throttle stick to set preferred Battery Protection Mode within the 5 tones. (Refer to Chart A) A confirmation sound will kick in when finish.
於5音節之音樂響音時以強制油門選擇設定，設定正確時將有連綿響音確認，結束時將有連續響音確認



8

Use throttle stick to set preferred Aircraft Mode within the 5 tones. (Refer to Chart A) A confirmation sound will kick in when finish.
於5音節之音樂響音時以強制油門選擇設定，設定正確時將有連綿響音確認，結束時將有連續響音確認



9

Use throttle stick to set preferred Throttle Response Speed Mode within the 5 tones. (Refer to Chart A) A confirmation sound will kick in when finish.
於5音節之音樂響音時以強制油門選擇設定，設定正確時將有連綿響音確認，結束時將有連續響音確認



10

Use throttle stick to set preferred BEC Output Voltage Mode within 5 tones. (Refer to Chart A) A confirmation sound will kick in when finish.
於5音節之音樂響音時以強制油門選擇設定，設定正確時將有連綿響音確認，結束時將有連續響音確認



STEP 5 步驟5
Tilt the helicopter to the right and swashplate should tilt left to compensate. If reversed, perform the flybarless initial setup again and adjust the aileron reverse setting (Refer to P.26: A:REV setup)
將直昇機往右傾，陀螺儀應將十字盤向左修正，如果反向，重新進入Flybarless設定模式設定副翼陀螺儀修正方向。(如左圖所示：參考P.26 A.REV副翼陀螺儀修正反向設定模式)

STEP 6 步驟6
With throttle stick all the way up (and down), and cyclic stick all the way left/right and up/down, check for any binding on the swashplate. If binding occurs, perform the flybarless initial setup again and adjust the endpoint limits.
將油门搖桿推到最高及最低，並將搖桿左右及前後推到底，十字盤動作是否流暢，如果不是必須重新進入Flybarless設定模式裏設定行程。

STEP 7 步驟7
Check the center of gravity (CG) and adjust component placement until CG point is right on the main shaft of the helicopter.
檢視直升機重心是否適當請先調整直昇機重心位置至主軸中心線下方位置。

STEP 8 步驟8
With all above steps checked, restart the system and begin flight test.
確定所有功能正常，重新開機，完成開機程序後進入飛行測試。

HELICOPTER CG CHECK PROCEDURE 直昇機機體重心檢視方式

After the battery is assembled, hold the helicopter as shown. Once the helicopter stops rotating, the helicopter's CG can be seen at where the head is pointing relative to the main shaft.

將電池固定於電池座後，將直昇機如圖示舉起，等待直昇機停止轉動後檢視機頭方向，正確重心應落在機身（主軸附近）位置。

Adjust the frame's CG within +/- 60 degrees from level.
以水平線上下夾角 60° 內為適當的範圍來調整機體的重心。

19. FLIGHT ADJUSTMENT AND SETTING 飛行動作調整與設定

PLEASE PRACTICE SIMULATION FLIGHT BEFORE REAL FLYING 飛行前請事先熟練電腦模擬飛行









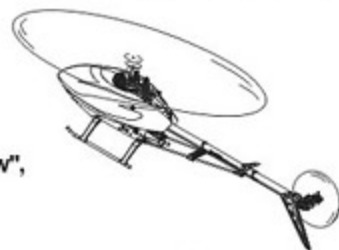











A safe and effective practice method is to use the transmitter flying on the computer through simulator software sold on the market. Do a simulation flight until you familiarize your fingers with the movements of the rudders, and keep practicing until the fingers move naturally.

1. Place the helicopter in a clear open field and the tail of helicopter point to yourself.
2. Practice to operate the throttle stick (as below illustration) and repeat practicing "Throttle high/low", "Aileron left/right", "Rudder left/right", and "Elevator up/down".
3. The simulation flight practice is very important, please keep practicing until the fingers move naturally when you hear operation orders being call out.

在還沒瞭解直昇機各動作的操控方式前，嚴禁實機飛行，請先進行電腦模擬飛行的練習，一種最有效、最安全的練習方式，就是透過市面販售的模擬軟體，以遙控器在電腦上模擬飛行，熟悉各種方向的操控，並不斷的重複，直到手指可熟練的控制各個動作及方向。

1. 將直昇機放在空曠的地方，並將直昇機的機尾對準自己。
2. 練習操作遙控器的各搖桿(各動作的操作方式如下圖)，並反覆練習油门高/低、副翼左/右、升降舵前/後及方向舵左/右操作方式。
3. 模擬飛行的練習相當重要，請重複練習直到不需思索，手指能自然隨著喊出的指令移動控制。



Mode 1	Mode 2	Illustration 圖示
 Aileron 副翼 	 Move left 左移  Rotate left 左翻	 Move right 右移  Rotate right 右翻
 Elevator 升降/前後 	 Fly forward 前進  Forward rotate 前翻	 Fly backward 後退  backward rotate 後翻
 Throttle 油門 		 Ascent 上升  Descent 下降
 Rudder 方向 	 Turn right 右旋  Turn left 左旋	

FLIGHT ADJUSTMENT AND NOTICE 飛行調整與注意



- Check if the screws are firmly tightened.
- Check if the transmitter and receivers are fully charged.
- 再次確認→螺絲是否鎖固?
- 發射器和接收器電池是否足夠。



If there are other radio control aircraft at the field, make sure to check their frequencies and tell them what frequency you are using. Frequency interference can cause your model, or other models to crash and increase the risk of danger.
假使飛行場有其他遙控飛機，請確認他們的頻率，並告知他們你正在使用的頻率，相同的頻率會造成干擾導致失控和大大地增加風險。

- ★ When arriving at the flying field.
- ★ 當抵達飛行場



STARTING AND STOPPING THE MOTOR 啟動和停止馬達

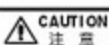

First check to make sure no one else is operating on the same frequency. Then place the throttle stick at lowest position and turn on the transmitter.
首先確認附近沒有其他相同頻率的使用，然後打開發射器將油門搖桿推到低點。

- ★ Check the movement.
- ★ 動作確認



ON! Step1
First turn on the transmitter.
先開啟發射器



Check if the throttle stick is set at the lowest position.
確認油門搖桿是在最低的位置。

Mode 1 Mode 2

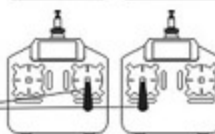

- Are the rudders moving according to the controls?
- Follow the transmitter's instruction manual to do a range test.
- 方向舵是否隨著控制方向移動?
- 根據發射器說明書進行距離測試。



ON! Step2
Connect to the helicopter power
接上直昇機電源



OFF! Step3
Reverse the above orders to turn off.
關閉電源時請依上述操作動作反執行。

This procedure is best performed on soft surfaces such as grass. The use of rubber skid stopper is recommended on hard surface to prevent vibration feedback from the ground to 3GX, resulting in over-corrections.

將直升機置於柔軟地面上，建議硬地起飛腳架裝上避震墊圈。避免升空前腳架與過硬的地面震動太大反饋至機身上的3GX，影響無平衡翼系統升空前過度修正。

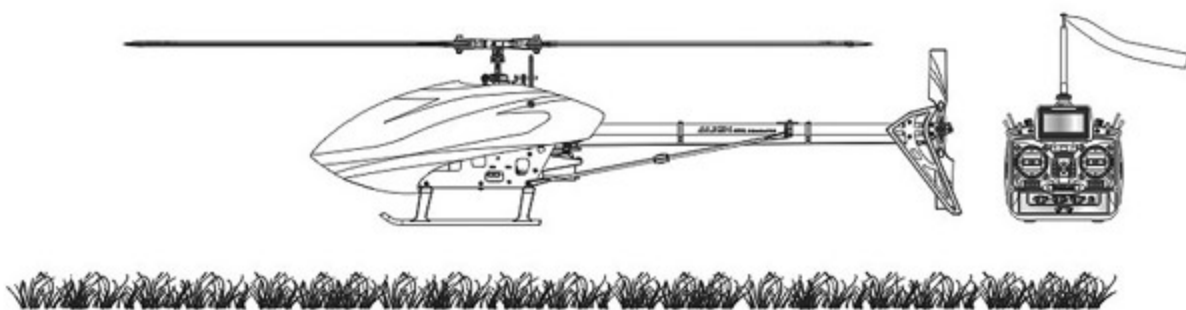

If swashplate should tilt prior to lift off, do not try to manually trim the swashplate level. This is due to vibration feedback to the 3GX, and will disappear once helicopter lifts off the ground. If manual trim is applied, helicopter will tilt immediately after liftoff.

直昇機離地前，十字盤可能因3GX受震動的反饋，使十字盤有傾斜的情形，此時請勿刻意將十字盤修正為水平狀態，此現象只要離地升空時立即解除，可平穩升空；若刻意將十字盤修正為水平時，反而會造成感應器過度修正，一離地即偏往修正方向的危險。

MAIN ROTOR ADJUSTMENTS 主旋翼雙槳平衡調整

1. Before adjusting, apply a red piece of tape on one blade, or paint a red stripe with a marker or paint to identify on blade.
2. Raise the throttle stick slowly and stop just before the helicopter lifts-off ground. Look at the spinning blades from the side of the helicopter.
3. Look at the path of the rotor carefully. If the two blades rotate in the same path, it does not need to adjustment. If one blade is higher or lower than the other blade, adjust the tracking immediately.

1. 調整前先在其中一支主旋翼的翼端，貼上有顏色的貼紙或畫上顏色記號，方便雙槳調整辨識。
2. 慢慢的推起油門搖桿到高點並且停止，在直昇機離開地面前，從直昇機側邊觀察主旋翼轉動。
3. 仔細觀察旋翼軌跡(假如兩支旋翼移動都是相同軌跡，則不需要調整;可是如果一支旋翼較高或較低產生“雙槳”的情形時，則必須立刻調整軌跡)。

A. When rotating, the blade with higher path means the pitch too big. Please shorten DFC ball link for regular trim.
B. When rotating, the blade with lower path means the pitch too small. Please lengthen DFC ball for regular trim.

- A. 旋翼轉動時較高軌跡的主旋翼表示螺距(PITCH)過大，請調短DFC連桿頭修正。
B. 旋翼轉動時較低軌跡的主旋翼表示螺距(PITCH)過小，請調長DFC連桿頭修正。



Tracking adjustment is very dangerous, so please keep away from the helicopter at a distance of at least 5m.

調整軌跡非常危險，請於距離飛機最少5公尺的距離。

Incorrect tracking may cause vibrations. Please repeat adjusting the tracking to make sure the rotor is correctly aligned. After tracking adjustment, please check the pitch angle is approx. $+5^\circ$ when hovering.

不正確的旋翼軌跡會導致震動，請不斷重複調整軌跡，使旋翼軌跡精準正確。在調整軌跡後，確認一下Pitch角度在停旋時應為大約 $+5^\circ$ 。

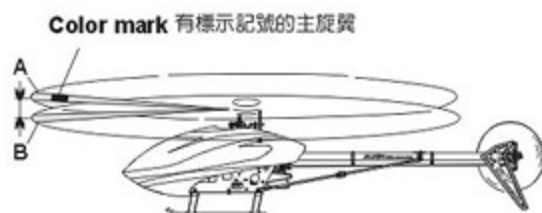

FLIGHT ADJUSTMENT AND NOTICE 飛行調整與注意

- ⊙ During the operation of the helicopter, please stand approximately 5m diagonally behind the helicopter.
⊙ 飛行時，請站在直昇機後方5公尺。



- ⊙ Make sure that no one or obstructions in the vicinity.
⊙ For flying safety, please carefully check if every movement and directions are correct when hovering.
⊙ 確認鄰近地區沒有人和障礙物。
⊙ 為了飛行安全，您必須先確認停懸時各項操控動作是否正常。



Do not attempt until you have some experiences with the operation of helicopter.
嚴禁無熟練操控飛行經驗者操控飛行。

STEP 1 THROTTLE CONTROL PRACTICE 油門控制練習

◎When the helicopter begins to lift-off the ground, slowly reduce the throttle to bring the helicopter back down. Keep practicing this action until you control the throttle smoothly.

◎當直昇機開始離地時，慢慢降低油門將飛機降下。
持續練習飛機從地面上的上升和下降直到你覺得油門控制很順。

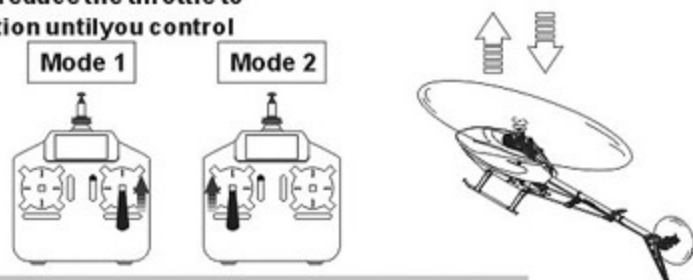

STEP 2 AILERON AND ELEVATOR CONTROL PRACTICE 副翼和升降控制練習

1. Raise the throttle stick slowly.
2. Move the helicopter in any direction back, forward, left and right, slowly move the aileron and elevator sticks in the opposite direction to fly back to its original position.

1. 慢慢升起油門搖桿。
2. 使直昇機依指示：移動向後/向前/向左/向右，慢慢的反向移動副翼和升降搖桿並將直昇機開回到原來位置。

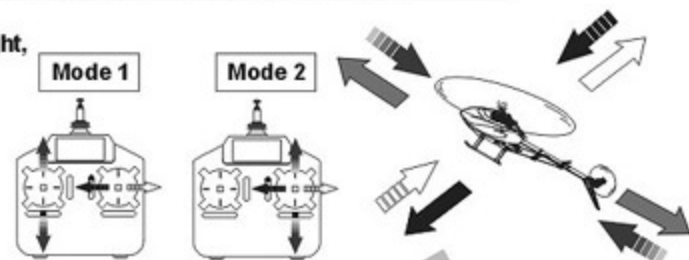

◎If the nose of the helicopter moves, please lower the throttle stick and land the helicopter. Then move your position diagonally behind the helicopter 5m and continue practicing.
◎If the helicopter flies too far away from you, please land the helicopter and move your position behind 5m and continue practicing.
◎當直昇機機頭偏移時，請降低油門並且降落，然後移動自己的位置到直昇機的正後方5公尺再繼續練習。
◎假如直昇機飛離你太遠，請先降落直昇機，並到直昇機後5公尺再繼續練習。

STEP 3 RUDDER CONTROL PRACTICING 方向舵操作練習

1. Slowly raise the throttle stick.
2. Move the nose of the helicopter to right or left, and then slowly move the rudder stick in the opposite direction to fly back to its original position.

1. 慢慢升起油門搖桿。
2. 將直昇機機頭移動左或右，然後慢慢反向移動方向舵搖桿並將直昇機飛回原本位置。

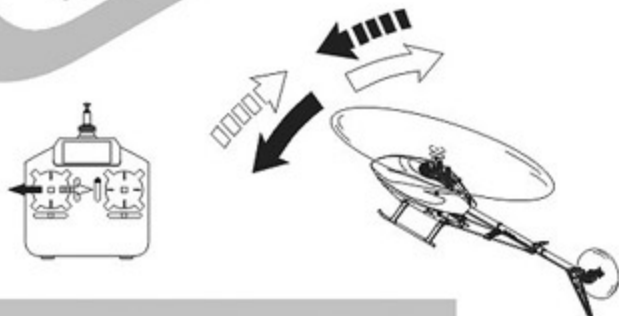

STEP 4

After you are familiar with all actions from Step 1 to 3, draw a circle on the ground and practice within the circle to increase your accuracy.

◎You can draw a smaller circle when you get more familiar with the actions.

當你覺得 step1~3 動作熟悉了，在地上畫圈並在這個圈內的範圍內練習飛行，以增加你操控的準確度。

◎當你更加習慣操作動作，你可以畫更小的圈圈。



STEP 5 DIRECTION CHANGE AND HOVERING PRACTICE 改變直昇機方向和練習停懸

After you are familiar with Step 1 to 4, stand at side of the helicopter and continue practicing Step 1 to 4. Then repeat the Step 1 to 4 by standing in front of the helicopter.

當你覺得step1~4動作熟悉了，站在面對直昇機側邊並繼續練習step1~4。之後，站在直昇機機頭前方重複步驟練習。

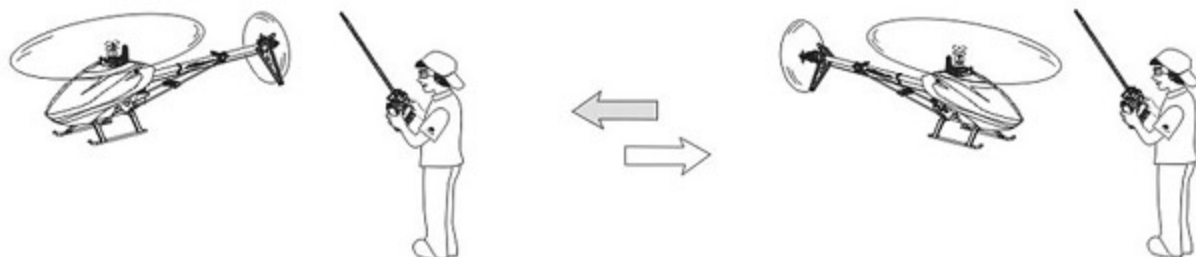

With the helicopter hovering, observe for any rapid left/right or forward/aft oscillations. If forward/aft oscillation is observed, land the helicopter, turn the ELE gain dial counterclockwise gradually, and test again. Do this until oscillation disappears.

先將直昇機以停懸飛行，觀察直昇機左右及前後是否有不正常快速抖動現象，如果前後有抖動情形，則逆時針調降升降舵感度調整旋鈕，以減少陀螺儀前後修正感度。

SET THE DIAL TO 12 O'CLOCK POSITION AS STARTING POINT 建議初次飛行設於12點鐘方向

Elevator gain adjustment dial 升降舵感度調整旋鈕

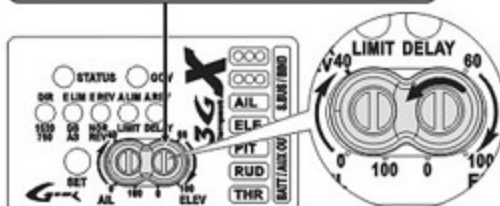

Decrease ELE gain
調降ELE感度



Forward/back oscillation
前後晃動



If left/right oscillation is observed, land the helicopter, turn the AIL gain dial counterclockwise gradually, and test again. Do this until oscillation disappears.

如果為左右抖動，逆時針調降副翼感度調整旋鈕，以減少陀螺儀左右修正感度。

SET THE DIAL TO 12 O'CLOCK POSITION AS STARTING POINT 建議初次飛行設於12點鐘方向

Aileron gain adjustment dial 副翼感度調整旋鈕

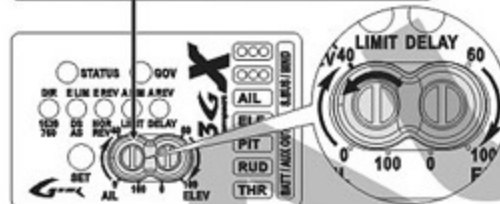

Decrease AIL gain
調降AIL感度



Left/right oscillation
左右晃動



FORWARD STRAIGHT LINE FLIGHT 前進直線航道飛行

After hovering, proceed to fast forward flight. Should there be similar oscillation, please reduce elevator gain. Should the helicopter pitch up or experience slow response during flight, increase elevator gain. Repeat this process until ideal gain values are achieved. Similar method is used to set the aileron gain. After adjusting gyro gains, adjust the roll rate in 3GX Flight Mode settings based on your preference. Higher the roll rate, the faster the roll/flips are. Pilot can also adjust the cyclic EXP setting for the preferred stability. After all adjustments are complete, the pilot can enjoy the stability of slow flight and the fast agility from flybarless system.

停懸完後可快速前進飛行，同樣的如果有不正常抖動時，請將升降舵感度調小，飛行時如果有機頭向上仰起或反應緩慢現象時，請將感度調大，重複測試將感度調整至最理想值，同樣方式可調整副翼感度旋鈕。調整完陀螺儀感度，可依據飛行習慣進入3GX飛行特性設定調整滾轉速率，調整越大，前後及左右滾轉速度越快，使用者也可依據個人經驗調整舵面EXP以增加停懸穩定性。完成所有調整後，就可享受Flybarless所提供低速飛行的穩定性及高速時的靈活性。



Forward Flight
前進飛行



	Problem 狀況	Cause 原因	Solution 對策
Blade Tracking 雙槳平衡	Tracking is Off 雙槳	Pitch linkage rods are not even length PITCH連桿長度調整不平均	Adjust length of pitch linkage rods (A) 調整DFC連桿頭長度
Hover 停懸	Head speed too low 主旋翼轉速偏低	Excessive pitch 主旋翼的PITCH偏高	Adjust pitch linkage rods (A) to reduce pitch by 4 to 5 degrees. Hovering headspeed should be around 2800RPM. 調整連桿頭調低Pitch約+4~5度 (停懸時主旋翼需為約2800RPM)
		Hovering throttle curve is too low 停懸點油門曲線過低	Increase throttle curve at hovering point on transmitter (around 65%) 調高停懸點油門曲線(約65%)
	Head speed too high 主旋翼轉速偏高	Not enough pitch 主旋翼的PITCH偏低	Adjust pitch linkage rods (A) to increase pitch by 4 to 5 degrees. Hovering headspeed should be around 2800RPM. 調整連桿頭調高Pitch約+4~5度 (停懸時主旋翼需為約2800RPM)
		Hovering throttle curve is too high 停懸點油門曲線過高	Decrease throttle curve at hovering point on transmitter (around 65%) 調低停懸點油門曲線(約65%)
Rudder Response 尾舵反應	Drifting of tail occurs during hovering, or delay of rudder response when centering rudder stick. 停懸時尾翼向某一邊偏移，或撥動方向舵並回復到中立點時，尾翼產生延遲，無法停頓在所控制位置上。	Rudder neutral point improperly set 尾中立點設定不當	Reset rudder neutral point 重設尾中立點
	Tail oscillates (hunting, or wags) at hover or full throttle 停懸或全油門時尾翼左右來回搖擺。	Rudder gyro gain too low 尾舵陀螺儀感度偏低	Increase rudder gyro gain 增加尾舵陀螺儀感度
		Rudder gyro gain too high 尾舵陀螺儀感度偏高	Reduce rudder gyro gain 降低尾舵陀螺儀感度
Oscillation during flight 飛行抖動	Forward/aft oscillation when elevator is applied 升降舵打舵動作時，機體前後抖動	Elevator gyro gain too high. 升降舵陀螺感度偏高，產生追蹤現象	Turn the ELE gain dial on 3GX counterclockwise, 10 degrees at a time until oscillation is eliminated. 逆時針調整3GX上的升降舵感度調整旋鈕，以每次調整約10度的方式，調整至適當位置
	Helicopter front bobbles (nods) during forward flight. 直線飛行時，機頭點頭	Worn servo, or slack in control links 伺服器老化，控制結構有虛位	Replace servo, ball link, or linkage balls. 更換伺服器、連桿頭、球頭
	Left/right oscillation when aileron is applied 副翼打舵動作時，機體左右抖動	Aileron gyro gain too high 副翼陀螺感度偏高，產生追蹤現象	Turn the AIL gain dial on 3GX counterclockwise, 10 degrees at a time until oscillation is eliminated. 逆時針調整3GX上的副翼感度調整旋鈕，以每次調整約10度的方式，調整至適當位置
	Elevator input causes helicopter to drift 升降舵動作飄移	Worn servo, or slack in control links 伺服器老化，控制結構有虛位	Replace servo, ball link, or linkage balls. 更換伺服器、連桿頭、球頭
Drifting during flight 飛行飄移	Helicopter pitches up during forward flight 直線飛行機頭上揚	Elevator gyro gain too low 升降舵陀螺感度偏低	Turn the ELE gain dial on 3GX clockwise, 10 degrees at a time until drifting is eliminated. 順時針調整3GX上的升降舵感度調整旋鈕，以每次調整約10度的方式，調整至適當位置
	Aileron input causes helicopter to drift 副翼動作飄移	Aileron gyro gain too low 副翼陀螺感度偏低	Turn the AIL gain dial on 3GX clockwise, 10 degrees at a time until drifting is eliminated. 順時針調整3GX上的升降舵感度調整旋鈕，以每次調整約10度的方式，調整至適當位置
Control Response 動作反應	Slow Forward/Aft/Left/Right input response 前後左右飛行動作反應偏慢	Roll rate too low 滾轉速率偏低	Adjust roll rate within 3GX Flight Mode setting. 調整3GX飛行特性設定內的滾轉速率值
	Sensitive Forward/Aft/Left/Right input response 前後左右飛行動作反應偏快	Roll rate too high 滾轉速率偏高	Adjust roll rate within 3GX Flight Mode setting. 調整3GX飛行特性設定內的滾轉速率值

If above solution does not resolve your issues, please check with experienced pilots or contact your Align dealer.

※在做完以上調整後，仍然無法改善情況時，應立即停止飛行並向有經驗的飛手諮詢或連絡您的經銷商。

Q&A 1 Failure in 3GX update, resulting in unbootable, how to deal with?

Please restore the version of 3GX V1.0, let the 3GX hardware operate functionally.

Step 1: Install 3GX USB driver with computer and 3GX hardware, do not turn on the power of 3GX hardware at this time.

Step 2: select C drive at your computer, than follow below steps to find the 3GX welcome screen of "3GX_Update V1.0.exe", C:\My_setting\3GX\ALIGN_sys\Update\Former\3GX_Update V1.0.exe, then perform 3GX_Update V1.0.exe.

Step 3: Turn on the power of 3GX hardware, click "Update" bottom at 3GX welcome screen, then 3GX software will revert to 3GX V1.0.

Step 4: After restoration, 3GX hardware can be operate functionally, then can be update 3GX V4.0 Or other your favorite 3GX version.

3GX 更新失敗，造成無法開機使用，如何處理？

依照下列步驟將 3GX 還原成 V1.0 版本，即可恢復 3GX 正常。

步驟 1. 將 3GX 傳輸線(USB)與 3GX 連接，此時 3GX 先不開機電源。

步驟 2. 請到電腦 C 槽依下面路徑找到 3GX_Update V1.0.exe，C:\My_setting\3GX\ALIGN_sys\Update\Former\3GX_Update V1.0.exe，然後執行 3GX_Update V1.0.exe。

步驟 3. 將 3GX 接上電源，並在接電之後按下視窗上的 Update 按鈕，3GX 系統會還原成 1.0 版本。

步驟 4. 還原之後 3GX 便可以正常使用，只要再把 3GX 更新到 V4.0 即可。

Q&A 2 Pitches up during fast forward flight.

(1) Elevator gyro gain too low, increase the elevator gain by gradually turning the ELE dial clockwise.

(2) Elevator trim not centered. Check if helicopter is tilting backwards during hover.

快速飛行時直昇機機頭會上揚？

(1) ELE 感度不足，請稍微將 ELE 感度旋鈕順時針方向調高。

(2) ELE 中立點不對，請測試停懸時，直昇機中立點是否朝後。

Q&A 3 Insufficient gain during flight, but increasing gain results in oscillation.

(1) Check and resolve possible mechanical vibration from helicopter.

(2) Use softer 3GX mounting foam, or double up the stock 3GX foam.

(3) Relocate the 3GX to location less prone to vibration.

飛行時感度不足，將感度調高直昇機卻會抖動？

(1) 檢查直昇機是否有異常震動，如果是請先修復機體。

(2) 用材質較軟或兩片雙面膠泡棉固定 3GX。

(3) 將 3GX 換裝於直昇機較不震動的位置。

Q&A 4 Drifting during 3D maneuvers.

(1) Increase AIL and ELE gain by turning both dials clockwise.

(2) Check if cyclic servos are too slow (minimum 0.1sec / 60 degrees).

3D 飛行時有飄移現象？

(1) 將升降與副翼感度旋鈕順時針方向調高。

(2) 檢查推動十字盤的伺服器是否過慢（建議選擇動作速度 0.1sec/60 度以內規格）。

Q&A 5 Unstable hover, control inputs are too sensitive.

Can adjust the roll rate within 3GX Flight Mode settings, as well as increase the EXP setting to increase hovering stability. For CCPM machines, decrease swashplate mixing percentage on the transmitter. In addition, exponential can be added to aileron and elevator channels.

停懸時不穩定，有動作過靈敏現象？

可調低 3GX 飛行風格設定內的滾轉速率值，並增加 EXP 的設定，以提高停懸的穩定性。

Q&A 6 Helicopter oscillates after fast forward flight or after tumbles.

(1) Gradually reduce both AIL and ELE gain by turning them counterclockwise, 10 degrees at a time.

(2) Use harder head dampener.

直昇機高速飛行或滾轉後停止時，機身會有輕微抖動現象？

(1) 逆時針調整 3GX 上的升降舵感度調整旋鈕，以每次調整約 10 度的方式，調整至適當位置。

(2) 主旋翼槓軸及主軸連結的橡膠過軟，請換用較硬的橡膠。

Q&A 7 While in flybarless setup mode, unable to complete ELE/AIL endpoint and reverse settings.

Disable all trims/subtrims on the transmitter.

進入 Flybarless 設定，無法順利完成 ELE、AIL 行程、ELE 或 AIL 的 REV 燈號？

未取消遙控器的內外微調。

Q&A 8 Incorrect CCPM mixing after initial flybarless setup.

(1) Trim/subtrims not zeroed out on transmitter.

(2) After any trim adjustments are done on transmitter, the initial flybarless setup procedure need to be performed again.

(3) Please turn off the swash ring, Linkage Compensation, Swash Mix, Mixing, Acceleration and other collective mixing Functions in the transmitter.

完成 Flybarless 設定，但 CCPM 混控動作不正常？

(1) 進入 Flybarless 設定時未將外微調歸零。

(2) 遙控器變更內微調，未重新進行 Flybarless 設定。

(3) 請關閉遙控器內 Swash ring、Linkage Compensation、Swash Mix、Mixing、Acceleration 等混控功能。

Q&A 9 3GX flybarless system unable to power up.

(1) Check proper voltage source.

(2) Check AIL/ELE/PIT connections between flybarless control unit and receiver.

(3) Check the power connection of 3GX and receiver.

3GX Flybarless 無法開機？

(1) 檢查系統電源是否正常。

(2) 檢查 AIL、ELE 及 PIT 的訊號線和接收器是否正確連接。

(3) 檢查 3GX 與接收器間電源線是否正確連接。

Q&A 10 3GX flybarless system powers up with LED flashing, but swashplate did not jump 3 times, pitch is locked, unable to complete the initialization process.

(1) Possible movement during initialization process. Make sure helicopter is absolutely stationary.

(2) If STATUS LED flashes red, check the connection between controller and receiver.

3GX Flybarless 開機後閃燈正常，十字盤未跳動，PIT 被鎖定，無法順利完成開機動作？

(1) 開機時直昇機必須完全靜止，才可順利開機。

(2) 檢查如果 STATUS 紅綠燈號一直閃爍，請檢查遙控器與接收器是否正常工作。

Q&A 11 I noticed swashplate tilts slightly at extreme pitch due to servo interactions, should I make efforts to level it out? No. Level the swashplate at 0 degrees using subtrims ONLY in DIR setup mode. (please refer to page 24 step 1.3)

End point swashplate interactions are automatically compensated by the 3GX system while in flight.

十字盤移動到最高與最低位置時會有些微傾斜，我能嘗試將它修正調整到水平嗎？

否。在 DIR 模式時利用內微調 (Subtrims) 將十字盤 0 度時調整至水平 (參閱第 24 頁 步驟 1.3)。實際飛行時，3GX 系統會自動修正十字盤的混控位差。

Q&A 12 What adjustments can I make on the transmitter after the DIR setup has been completed? You can adjust the trim tabs, dual rates, exponential, collective pitch. Again do NOT adjust the subtrims unless followed by repeating of DIR setup steps.

在離開 DIR 模式後，有哪些調整功能是我能使用的？

一般開機模式下，你仍然可以使用以下幾個功能調整直昇機：舵面大小動 (dual rates, exponential)、集體螺距 (collective pitch)。

Q&A 13 During step 5 of DIR setup mode, only aileron swash mixing was mentioned. Should I set elevator swash mixing as well? No. The 3GX system automatically calculates a cyclic ring based on the aileron swash mix percentage. Setting of elevator swash mix has no affect on the 3GX system. Set the cyclic pitch by the aileron swash mix & just use the same value for elevator.

在步驟五 - 循環螺距設定時，為何只測量副翼的角度？

3GX 系統在實際飛行時，會自動給定十字盤一個限圈運行，所以在測量副翼循環螺距角度後，設定相同數值的升降循環角度即可。

Q&A 14 Helicopter feels lack of stability during flight? Try to adjust the gain dials on the 3GX. Due to the difference of optimal gain settings amongst different helicopters, we recommend the gain dials to be set to mid position, then adjust the gain dial according to the behavior of helicopter, until optimal stability is reached. If you feel the gain cannot be increased further, please check for vibrations in helicopter and proper mounting of the 3GX.

P.S. Drastic adjustment should be avoided; adjust one clock tick at a time to prevent oscillation as result of excessive gain.

直昇機飛行時感覺穩定性不足？

可以由 3GX 面板上感度旋鈕提高直昇機感度。因為每一台直昇機的最佳感度會有些許不同，建議使用者先將感度旋鈕調到中立點，根據直昇機狀況增加旋鈕感度，直到直昇機可以更穩定。如果使用者覺得感度幾乎無法往上調，必須檢查直昇機是否有鬆動問題或 3GX 的固定不當。

P.S. 每次調整幅度不宜太多，一次以一點鐘的刻度增加，以免感度過高造成直昇機動作追蹤發散，而造成危險。

Q&A 15 Why is there spring action from sudden stops after fast pirouettes?

(1) First check for smoothness on rudder pushrods and tail pitch assembly.

(2) Check rudder servo to see if the response is too slow, or the servo has deteriorated from usage/age.

(3) Lower rudder locking gain from transmitter.

(4) Using 3GX PC link interface, adjust rudder anti-torque compensation value.

(5) Increase the rudder delay value through 3GX rudder configuration function.

尾舵快速旋轉急停時，會有回彈問題？

(1) 先檢查尾舵連桿及尾舵制組結構是否順暢。

(2) 檢查使用的尾舵伺服機，是否反應太慢或已經老化。

(3) 調低遙控器尾舵鎖定感度。

(4) 可以使用 3GX 軟體介面，調高或調低尾舵反扭力補償。

(5) 由 3GX 尾舵調整功能，調高尾舵延遲 (delay) 量。

Q&A 16 Helicopter cyclic response too fast or too slow? Can be adjusted using 3GX software interface. If response is too fast, raise the Flight Condition Control value to soften the pause after maneuvers; On the other hand, lowering the Flight Condition Control value will result in crisper stop points.

直昇機升降舵或副翼反應過快或過慢？

可以使用 3GX 軟體介面，如果反應太快，可以將飛行風格數值調高，飛行的停頓點會較柔和，反之可以將飛行風格數值調低，停止點會較為剛硬。

Q&A 17 Unable to maintain flat plane during pirouettes, or helicopter has tendency to tilt front/back/left/right during takeoff? Please level the swashplate again, and perform swash setting again.

直昇機尾舵自旋時盤面不平或起飛時直昇機有左右或前後傾斜現象？

請重新調整十字盤水平，然後完成十字盤設定。

Q&A 18 Helicopter has tendency to tilt front/back during straight ascend/descend? If helicopter tilts forward during ascend, lower the collective pitch to elevator compensation value through 3GX software interface. If it tilts backwards, raise this value.

直昇機直上直下時有前或後傾現象？

如果直上時直昇機有前傾現象，需使用 3GX 軟體介面調低集合螺距升降補償值，反之則需調高。

Q&A 19 Tail overshoots during fast pirouettes? Lower the rudder ATV value on your transmitter. Rudder ATV should not exceed 110%, or else overshoot may occur.

直昇機尾舵快速自旋時，尾舵會有超轉現象？

需調低遙控器尾舵 ATV 值，尾舵 ATV 不宜超過 110%，否則可能會發生尾舵超轉現象。

ALIGN

Specifications & Equipment/規格配備:

Length/機身長:705mm

Height/機身高:205mm

Main Blade Length/主旋翼長:360mm

Main Rotor Diameter/主旋翼直徑:804mm

Tail Rotor Diameter/尾旋翼直徑:171mm

Motor Pinion Gear/馬達齒輪:11T

Main Drive Gear/傳動主齒輪:121T

Autorotation Tail Drive Gear/尾驅動主齒:106T

Tail Drive Gear/尾翼傳動齒:25T

Drive Gear Ratio/齒輪傳動比:1:11:4.24

Flying Weight(without battery)/全配重(不含電池): Approx. 730g

