

Super Performance HELICOPTER **T-REX 450 PRO Kit**

INSTRUCTION MANUAL 使用說明書



Thank you for buying ALIGN products. The **T-REX 450PRO** is the latest technology in Rotary RC models. Please read this manual carefully before assembling and flying the new **T-REX 450PRO** helicopter. We recommend that you keep this manual for future reference regarding tuning and maintenance.

承蒙閣下選用亞拓遙控世界系列產品，謹表謝意。進入遙控世界之前必須告訴您許多相關的知識與注意事項，以確保您能夠在學習的過程中較得心應手。在開始操作之前，請務必詳閱本說明書，相信一定能夠給您帶來相當大的幫助，也請您妥善保管這本說明書，以作為日後參考。



Contents

1	INTRODUCTION 前言
1~2	SAFETY NOTES 安全注意事項
3	EQUIPMENT REQUIRED FOR ASSEMBLY 自備設備
3	PACKAGE ILLUSTRATION 包裝說明
4	SAFETY CHECK BEFORE FLYING 飛行前安全檢查重要事項
5~16	ASSEMBLY SECTION 組裝說明
17	EQUIPMENT ILLUSTRATION 設備建議配置圖示
18	BRUSHLESS SPEED CONTROLLER INSTALLTION SUGGESTION ESC無刷調速器安裝建議位置
18	CANOPY ASSEMBLY 機頭罩安裝
19	SERVO SETTING AND ADJUSTMENT 伺服器設定調整
19	ADJUSTMENTS FOR GYRO AND TAIL NEUTRAL SETTING 陀螺儀與尾翼中立點調整
20	PITCH AND THROTTLE SETTING 主旋翼螺距與油門設定
21	POWER COLLOCATION REFERENCE 原裝動力數據參考表
21~23	RCE-BL35X BRUSHLESS SPEED CONTROLLER INSTRUCTION MANUAL 無刷調速器使用說明
24~26	FLIGHT ADJUSTMENT AND SETTING 飛行動作調整與設定
27~34	PART NAMES AND OPTIONAL PART LIST 各部零件名稱與選購備品明細

Thank you for buying ALIGN Products. The T-REX 450 PRO Helicopter is designed as an easy to use, full featured Helicopter R/C model capable of all forms of rotary flight. Please read the manual carefully before assembling the model, and follow all precautions and recommendations located within the manual. Be sure to retain the manual for future reference, routine maintenance, and tuning. The T-REX 450 PRO is a new product developed by ALIGN. It features the best design available on the Micro-Heli market to date, providing flying stability for beginners, full aerobatic capability for advanced fliers, and unsurpassed reliability for customer support.

感謝您選購亞拓產品，為了讓您容易方便的使用 T-REX 450 PRO 直昇機、請您詳細的閱讀完這本說明書之後再進行組裝以及操作這台直昇機，同時請您妥善的保存這本說明書、作為日後進行調整以及維修的參考。T-REX 450 PRO 是由亞拓自行研發的新產品，不論你是需求飛行穩定性的初學者或是追求性能的飛行愛好者。T-REX 450 PRO 將是你最佳的選擇。

THE MEANING OF SYMBOLS 標誌代表涵義

 WARNING 警告	Mishandling due to failure to follow these instructions may result in damage or injury. 因為疏忽這些操作說明，而使用錯誤可能造成財產損失或嚴重傷害。
 CAUTION 注意	Mishandling due to failure to follow these instructions may result in danger. 因為疏忽這些操作說明，而使用錯誤可能造成危險。
 FORBIDDEN 禁止	Do not attempt under any circumstances. 在任何禁止的環境下，請勿嘗試操作。

IMPORTANT NOTES 重要聲明

R/C helicopters, including the T-REX 450 PRO are not toys. R/C helicopter utilize various high-tech products and Technologies to provide superior performance. Improper use of this product can result in serious injury or even death. Please read this manual carefully before using and make sure to be conscious of your own personal safety and the safety of others and your environment when operating all ALIGN products.

Manufacturer and seller assume no liability for the operation or the use of this product.

Intended for use only by adults with experience flying remote control helicopters at a legal flying field. After the sale of this product we cannot maintain any control over its operation or usage.

T-REX 450 PRO 遙控直昇機並非玩具，它是結合了許多高科技產品所設計出來的休閒用品，所以商品的使用不當或不熟悉都可能造成嚴重傷害甚至死亡，使用之前請務必詳讀本說明書，勿輕忽並注意自身安全。注意!任何遙控直昇機的使用，製造商和經銷商是無法對使用者於零件使用的損耗異常或組裝不當所發生之意外負任何責任，本產品是提供給有操作過模型直昇機經驗的成人或有相當技術的人員在旁指導於當地合法遙控飛行場飛行，以確保安全無虞下操作使用，產品售出後本公司將不負任何操作和使用控制上的任何性能與安全責任。

We recommend that you obtain the assistance of an experienced pilot before attempting to fly our products for the first time. A local expert is the best way to properly assemble, setup, and fly your model for the first time. The T-REX 450 PRO requires a certain degree of skill to operate, and is a consumer item. Any damage or dissatisfaction as a result of accidents or modifications are not covered by any warrantee and cannot be returned for repair or replacement. Please contact our distributors for free technical consultation and parts at discounted rates when you experience problems during operation or maintenance.

模型商品屬於需高操作技術且為消耗性之商品，如經拆裝使用後，會造成不等情況零件損耗，任何使用情況所造成商品不良或不滿意，將無法於保固條件內更換新品或退貨，如遇有使用操作維修問題，本公司全省分公司或代理商將提供技術指導、特價零件供應服務。

2. SAFETY NOTES 安全注意事項



Fly only in safe areas, away from other people. Do not operate R/C aircraft within the vicinity of homes or crowds of people. R/C aircraft are prone to accidents, failures, and crashes due to a variety of reasons including, lack of maintenance, pilot error, and radio interference. Pilots are responsible for their actions and damage or injury occurring during the operation or as of a result of R/C aircraft models.

遙控模型飛機、直昇機屬高危險性商品，飛行時務必遠離人群，人為組裝不當或機件損壞、電子控制設備不良，以及操控上的不熟悉、都有可能導致飛行失控損傷等不可預期的意外，請飛行者務必注意飛行安全，並需了解自負疏忽所造成任何意外之責任。



LOCATE AN APPROPRIATE LOCATION 遠離障礙物及人群

R/C helicopters fly at high speed, thus posing a certain degree of potential danger. Choose an a legal flying field consisting of flat, smooth ground without obstacles. Do not fly near buildings, high voltage cables, or trees to ensure the safety of yourself, others and your model. For the first practice, please choose a legal flying field and can use a training skid to fly for reducing the damage. Do not fly your model in inclement weather, such as rain, wind, snow or darkness.

直昇機飛行時具有一定的速度，相對的也潛在著危險性，場地的選擇也相對的重要，請需遵守當地法規到合法遙控飛行場地飛行。必須注意周遭有沒有人、高樓、建築物、高壓電線、樹木等等，避免操控的不當造成自己與他人財產的損壞。初次練習時，務必選擇在空曠合法專屬飛行場地並適當搭配練習架練習飛行，這對飛行失誤所造成的損傷將會大幅的降低。請勿在下雨、打雷等惡劣天候下操作，以確保本身及機體的安全。



PREVENT MOISTURE 遠離潮濕環境

R/C models are composed of many precision electrical components. It is critical to keep the model and associated equipment away from moisture and other contaminants. The introduction or exposure to water or moisture in any form can cause the model to malfunction resulting in loss of use, or a crash. Do not operate or expose to rain or moisture.

直昇機內部也是由許多精密的電子零組件組成，所以必須絕對的防止潮濕或水氣，避免在浴室或雨天時使用，防止水氣進入機身內部而導致機件及電子零件故障而引發不可預期的意外！



PROPER OPERATION 勿不當使用本產品

Please use the replacement of parts on the manual to ensure the safety of instructors. This product is for R/C model, so do not use for other purpose.

請勿自行改造加工，任何的升級改裝或維修，請使用亞拓產品目錄中的零件，以確保結構的安全。請確認於產品限界內操作，請勿過載使用，並勿用於安全、法令外其它非法用途。



OBTAIN THE ASSISTANCE OF AN EXPERIENCED PILOT 避免獨自操控

Before turning on your model and transmitter, check to make sure no one else is operating on the same frequency. Frequency interference can cause your model, or other models to crash. The guidance provided by an experienced pilot will be invaluable for the assembly, tuning, trimming, and actual first flight. (Recommend you to practice with computer-based flight simulator.)

至飛行場飛行前，需確認是否有相同頻率的同好正進行飛行，因為開啓相同頻率的發射機將導致自己與他人立即干擾等意外危險。遙控飛機操控技巧在學習初期有著一定的難度，要盡量避免獨自操作飛行，需有經驗的人士在旁指導，才可以操控飛行。(勤練電腦模擬器及老手指導是入門必要的選擇)



SAFE OPERATION 安全操作

Operate this unit within your ability. Do not fly under tired condition and improper operation may cause in danger.

請於自己能力內及需要一定技術範圍內操作這台直昇機，過於疲勞、精神不佳或不當操作，意外發生風險將可能會提高。



ALWAYS BE AWARE OF THE ROTATING BLADES 遠離運轉中零件

During the operation of the helicopter, the main rotor and tail rotor will be spinning at a high rate of speed. The blades are capable of inflicting serious bodily injury and damage to the environment. Be conscious of your actions, and careful to keep your face, eyes, hands, and loose clothing away from the blades. Always fly the model a safe distance from yourself and others, as well as surrounding objects. Never take your eyes off the model or leave it unattended while it is turned on. Immediately turn off the model and transmitter when you have landed the model.

當直昇機主旋翼與尾旋翼運轉時，切勿觸摸並遠離任何物件，以避免造成危險及損壞。



KEEP AWAY FROM HEAT 遠離熱源

R/C models are made up various forms of plastic. Plastic is very susceptible to damage or deformation due to extreme heat and cold climate. Make sure not to store the model near any source of heat such as an oven, or heater. It is best to store the model indoors, in a climate-controlled, room temperature environment.

遙控飛機多半是以 PA 纖維或聚乙烯、電子商品為主要材質，因此要盡量遠離熱源、日曬，以避免因高溫而變形甚至熔毀損壞的可能。











3.EQUIPMENT REQUIRED FOR ASSEMBLY 自備設備

ALIGN

RADIO TRANSMITTER AND ELECTRONIC EQUIPMENT REQUIRED FOR ASSEMBLY 自備遙控及電子設備

 <p>Transmitter (6-channel or more, helicopter system) 發射機(六動以上直昇機模式遙控器)</p>	 <p>Receiver(6-channel or more) 接收機(六動以上)</p>	 <p>11.1V 3S 2100~2500mAh Li-Po Battery x 1 pc 11.1V 3S 2100-2500mAh Li-Po電池 x 1</p>
 <p>Dial Pitch Gauge x 1pc 旋轉式螺距規 x 1</p>	 <p>DS410M Digital Servo x 3 DS410M數位伺服器 x 3</p>	 <p>GP750 Head Lock Gyro Combo GP750鎖定向陀螺儀組 (GP750+DS520)</p>

ADDITIONAL TOOLS REQUIRED FOR ASSEMBLY 自備工具

 <p>Scissors 剪刀</p>	 <p>Cutter Knife 刀子</p>	 <p>Diagonal Cutting Pliers 斜口鉗</p>	 <p>Needle Nose Pliers 尖嘴鉗</p>
 <p>Oil 潤滑油</p>	 <p>CA 瞬間膠</p>	 <p>Hexagon Screw Driver 六角螺絲起子 2.5mm/2mm/1.5mm/1.3mm</p>	 <p>Philips Screw Driver 十字螺絲起子 PH1(φ3.0mm)</p>

4.PACKAGE ILLUSTRATION 包裝說明

ALIGN

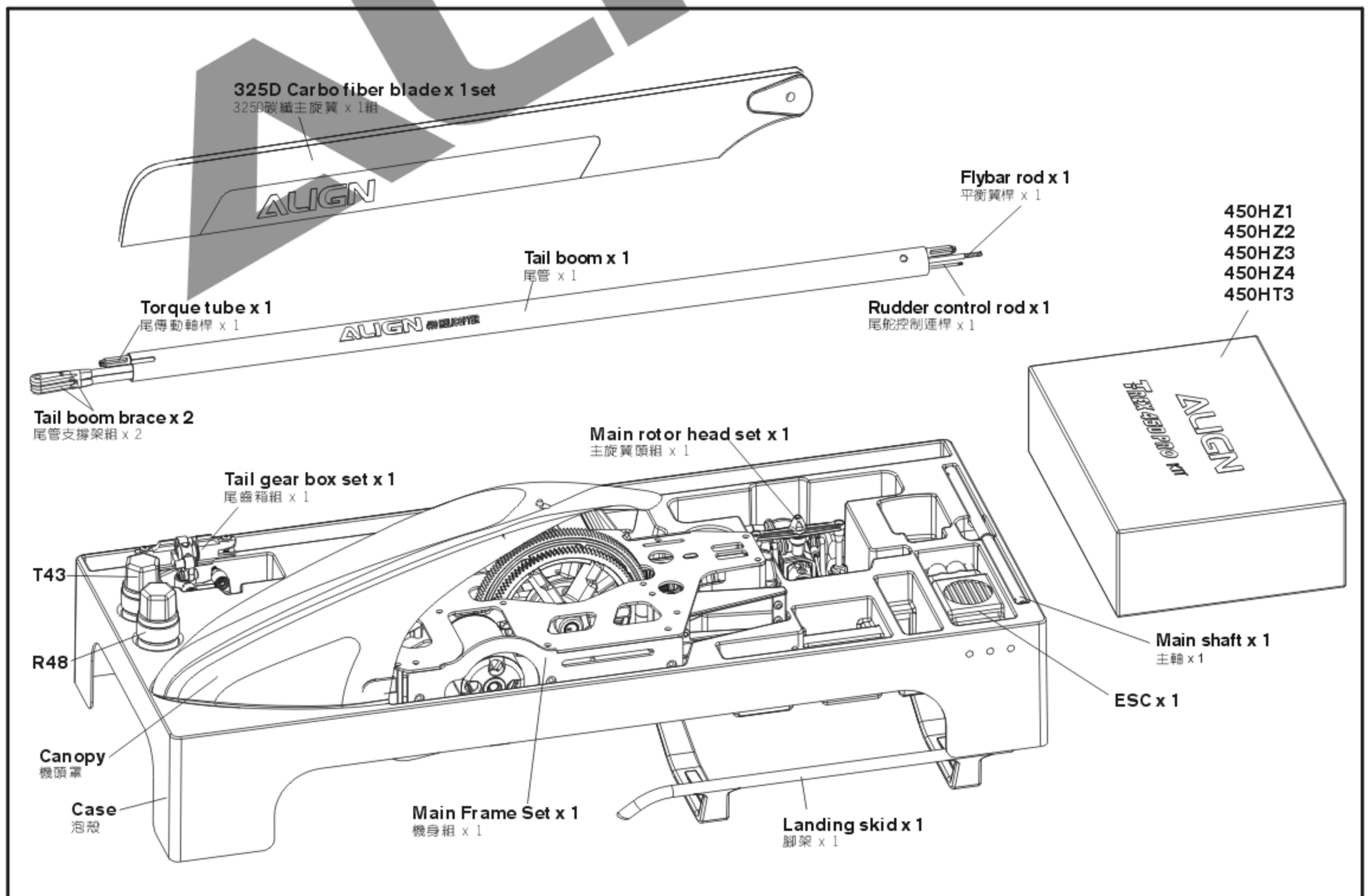

CAREFULLY INSPECT BEFORE REAL FLIGHT 實機飛行前請嚴格執行飛行前檢查義務

- ☆ **Before flying, please check to make sure no one else is operating on the same frequency for the safety.**
- ☆ **Before flight, please check if the batteries of transmitter and receiver are enough for the flight.**
- ☆ **Before turn on the transmitter, please check if the throttle stick is in the lowest position. IDLE switch is OFF.**
- ☆ **When turn off the unit, please follow the power on/off procedure. Power ON- Please turn on the transmitter first, and then turn on receiver. Power OFF- Please turn off the receiver first and then turn off the transmitter. Improper procedure may cause out of control, so please to have this correct habit.**
- ☆ **Before operation, check every movement is smooth and directions are correct. Carefully inspect servos for interference and broken gear.**
- ☆ **Check for missing or loose screws and nuts. See if there is any cracked and incomplete assembly of parts. Carefully check main rotor blades and rotor holders. Broken and premature failures of parts possibly cause resulting in a dangerous situation.**
- ☆ **Check all ball links to avoid excess play and replace as needed. Failure to do so will result in poor flight stability.**
- ☆ **Check the battery and power plug are fastened. Vibration and violent flight may cause the plug loose and result out of control.**

- ★ 每次飛行前應先確認所使用的頻率是否會干擾他人，以確保你自身與他人的安全。
- ★ 每次飛行前確定您發射機與接收機電池的電量是在足夠飛行的狀態。
- ★ 開機前確認油門搖桿是否位於最低點，熄火降落開關，定速開關(IDLE)是否於關閉位置。
- ★ 關機時必須遵守電源開關機的程序，開機時應先開啓發射機後，再開啓接收機電源；關機時應先關閉接收機後，再關閉發射機電源。不正確的開關程序可能會造失控的現象，影響自身與他人的安全，請養成正確的習慣。
- ★ 開機請先確定直昇機的各個動作是否順暢，及方向是否正確，並檢查伺服器的動作是否有干涉或崩齒的情形，使用故障的伺服器將導致不可預期的危險。
- ★ 飛行前確認沒有缺少或鬆脫的螺絲與螺帽，確認沒有組裝不完整或損毀的零件，仔細檢查主旋翼是否有損壞，特別是接近主旋翼夾座的部位。損壞或組裝不完整的零件不僅影響飛行，更會造成不可預期的危險。注意：對損耗、有裂痕零件更新及定期保養檢查的重要性。
- ★ 檢查所有的連桿頭是否有鬆脫的情形，過鬆的連桿頭應先更新，否則將造成直昇機無法操控的危險。
- ★ 確認電池及電源接頭是否固定牢靠，飛行中的震動或激烈的飛行，可能造成電源接頭鬆脫而造成失控的危險。

Standard Equipment 標準配備				
 450HC	 450HH1	 450HH2	 450HB1	 450HB2
 450HT1	 450HT2	 450HG1	 450HZ	 14T x1 M3x3 Set Screw x1 Motor Pinion Gear x 1 pc 馬達主齒 x 1
 450M Brushless motor x 1 450M無刷馬達 x 1		 RCE-BL35X Brushless ESC x 1 RCE-BL35X 35安培無刷調速器 x 1		 325D Carbon fiber blade x 1 325D碳纖主旋翼 x 1

When you see the marks as below, please use glue or grease to ensure flying safety.

標有下符號之組裝步驟，請配合上膠或上油，以確保使用之可靠度。



- CA: Apply CA Glue to fix.
- R48: Apply Anaerobics Retainer to fix.
- T43: Apply Thread Lock to fix.
- OIL: Add Grease.
- CA: 使用瞬間膠固定
- R48: 使用金屬管狀固定缺氧膠固定
- T43: 使用螺絲膠
- OIL: 添加潤滑油

When assembling ball links, make sure the "A" character faces outside.

各項塑膠製連桿頭扣接時，A字請朝外。

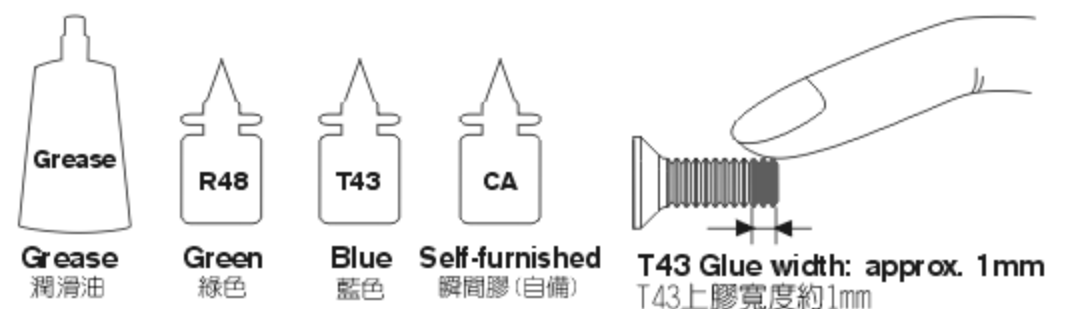

R48 metal tubular adhesive (eg. Bearings). T43 thread lock, apply a small amount on screws or metal parts and wipe surplus off. When disassembling, recommend to heat the metal joint about 15 Seconds. (NOTE: Keep plastic parts away from heat.)
R48 為強力金屬管狀(如軸承)接著劑，T43為螺絲膠，膠合螺絲或金屬內外徑請務必少量使用，必要時請用手去除多餘膠量，欲拆卸時可於金屬接合部位熱烤約15秒。(注意！塑膠件避免接近熱源)

450HH1

Apply a little amount of T43 thread lock when fixing a metal part.
螺絲鎖附於金屬件請使用適量T43(螺絲膠)

- Socket button head screw
半圓頭內六角螺絲(M2x5.5mm) x 2
- Bearing
軸承(φ2xφ5x2.5mm) x 2
- Bearing
軸承(φ2xφ5xφ6x2.3mm) x 2

CAUTION
注意

When tightening linkage balls and screws to plastic parts, please note to tighten them firmly and the best tightening torque is within 4~4.5 kgf.cm. Do not over tighten, or the plastic parts will break off or the screws strip.

螺絲及球頭鎖入塑膠件請務必注意，適當扭力鎖緊即可，鎖入力道控制在4~4.5kgf.cm內為佳。若力道太大可能會造成塑膠件破裂或螺絲滑牙、斷裂。

For original manufactory package, if the product is already assembled by Factory, please check again if screws are firmly secured and applied with some glue.

原廠零件出廠包裝如果是組裝品，請再確認各螺絲是否鎖緊上膠。

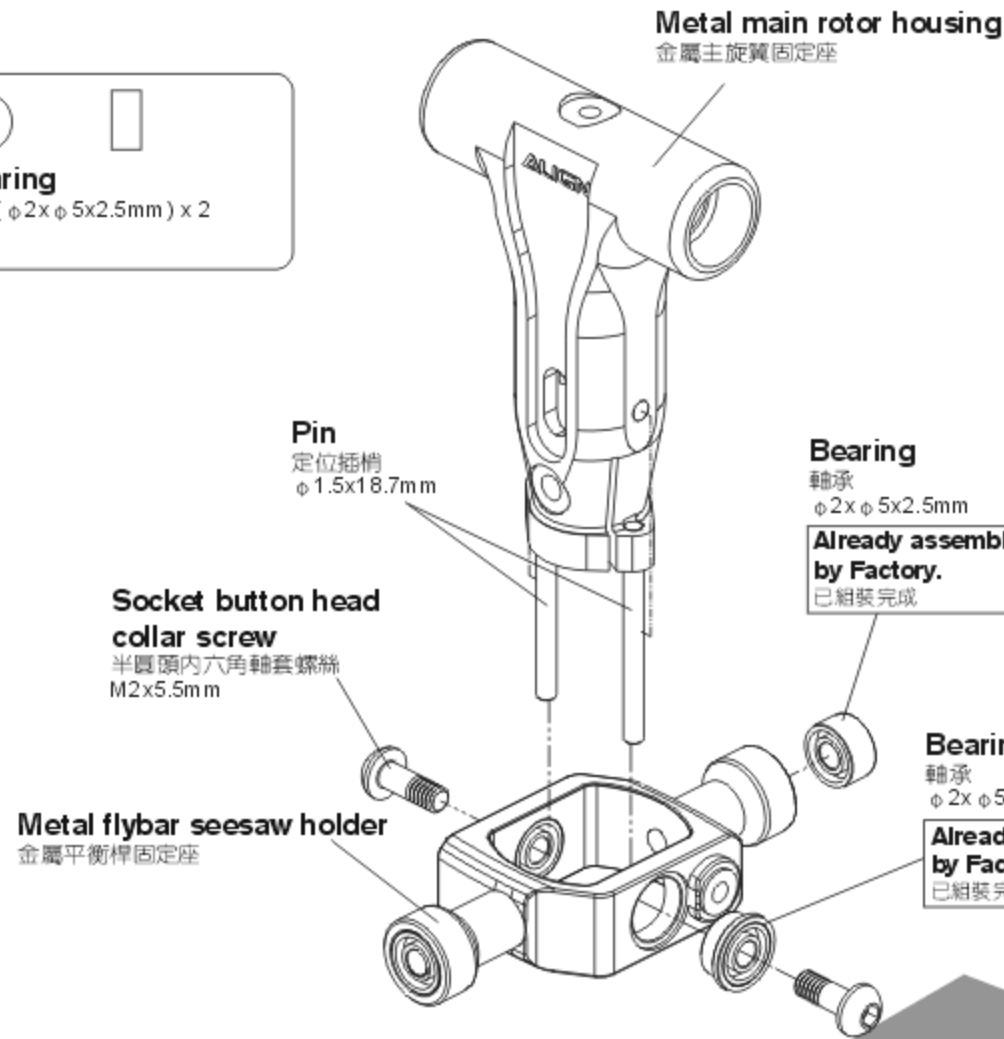

Bearing
軸承
φ2xφ5x2.5mm
Already assembled by Factory.
已組裝完成

Bearing
軸承
φ2xφ5xφ6x2.3mm
Already assembled by Factory.
已組裝完成

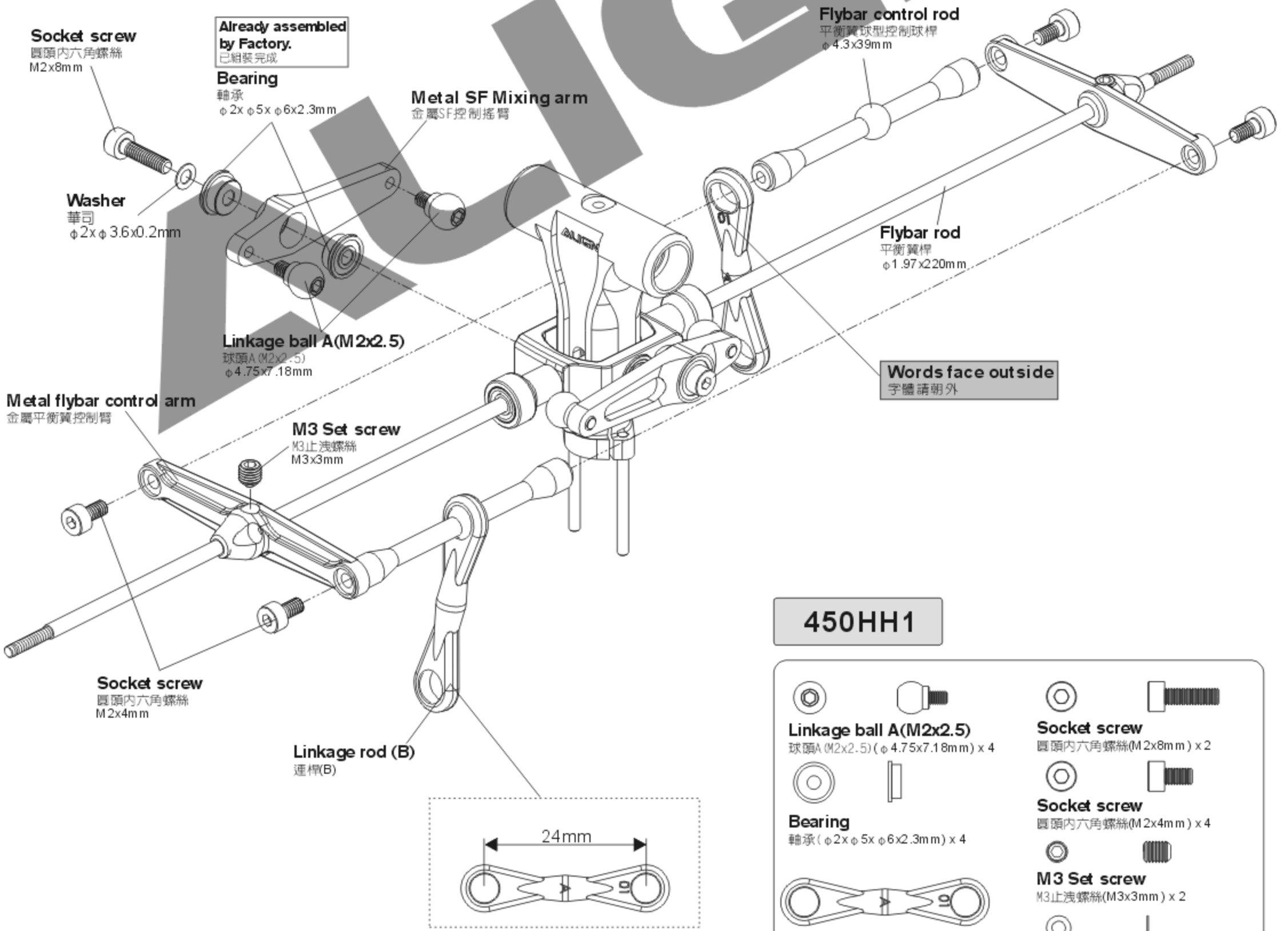

450HH1

- Linkage ball A (M2x2.5)
球頭A (M2x2.5) (φ4.75x7.18mm) x 4
- Bearing
軸承(φ2xφ5xφ6x2.3mm) x 4
- Linkage rod (B)
連桿(B) x 2
- Socket screw
圓頭內六角螺絲(M2x8mm) x 2
- Socket screw
圓頭內六角螺絲(M2x4mm) x 4
- M3 Set screw
M3止洩螺絲(M3x3mm) x 2
- Washer
華司(φ2xφ3.6x0.2mm) x 2

450HH1

Socket button head screw
半圓頭內六角螺絲(0#x4mm) x 4

Socket screw
圓頭內六角螺絲(M2x8mm) x 2

Bearing
軸承(φ2xφ5xφ6x2.3mm) x 4

Bearing
軸承(φ1.5xφ4x2mm) x 4

Linkage ball A(M2x2.5)
球頭A(M2x2.5)(φ4.75x7.18mm) x 8

Long linkage ball(M2x2.5)
導板長球頭(M2x2.5)(φ4.75x19.68mm) x 1

Washer
華司(φ2xφ3.6x0.2mm) x 2

450HZ1

Linkage rod (C)
連桿(C) φ1.3x32mm x 2

Ball link
連桿頭 x 4

Apply a little amount of T43 thread lock when fixing a metal part.
螺絲鎖附於金屬件請使用適量T43(螺絲膠)

450HB2

Socket collar screw
圓頭內六角軸套螺絲(M2x12mm) x 1

M2 Nut
M2螺帽 x 1

CAUTION
注意

For original manufactory package, if the product is already assembled by Factory, please check again if screws are firmly secured and applied with some glue.
原廠零件出廠包裝如果是組裝品，請再確認各螺絲是否鎖緊上膠。



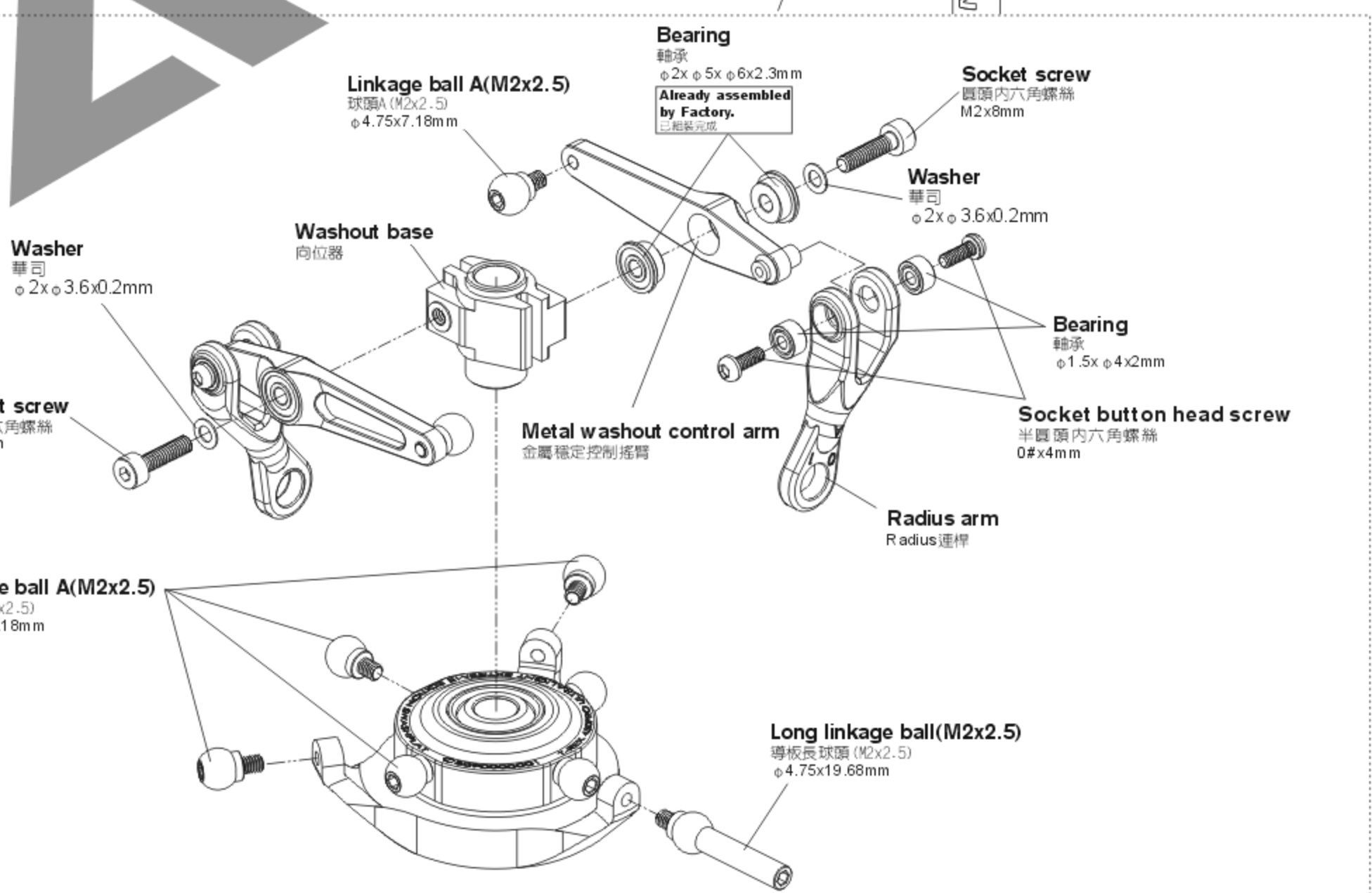
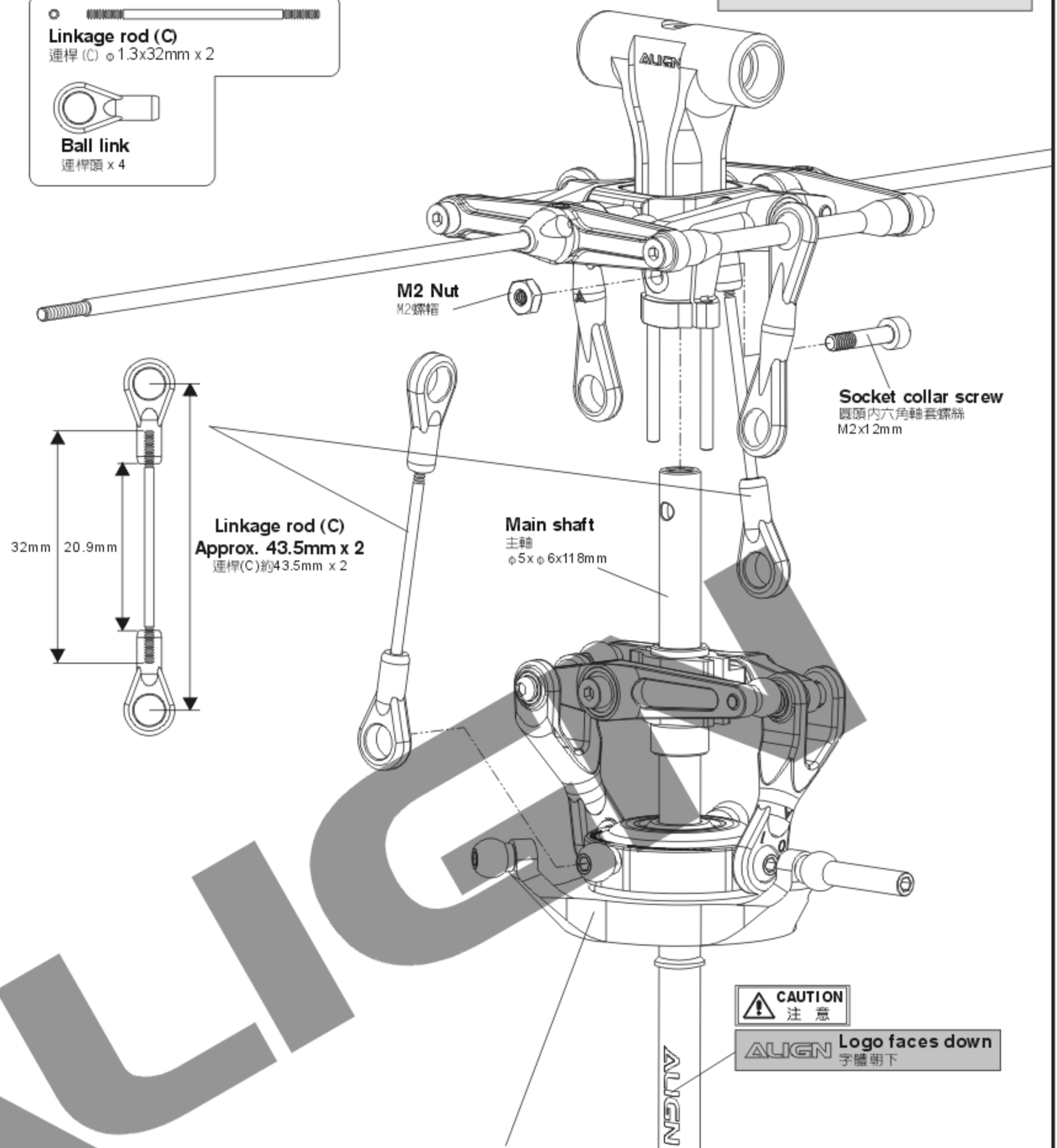



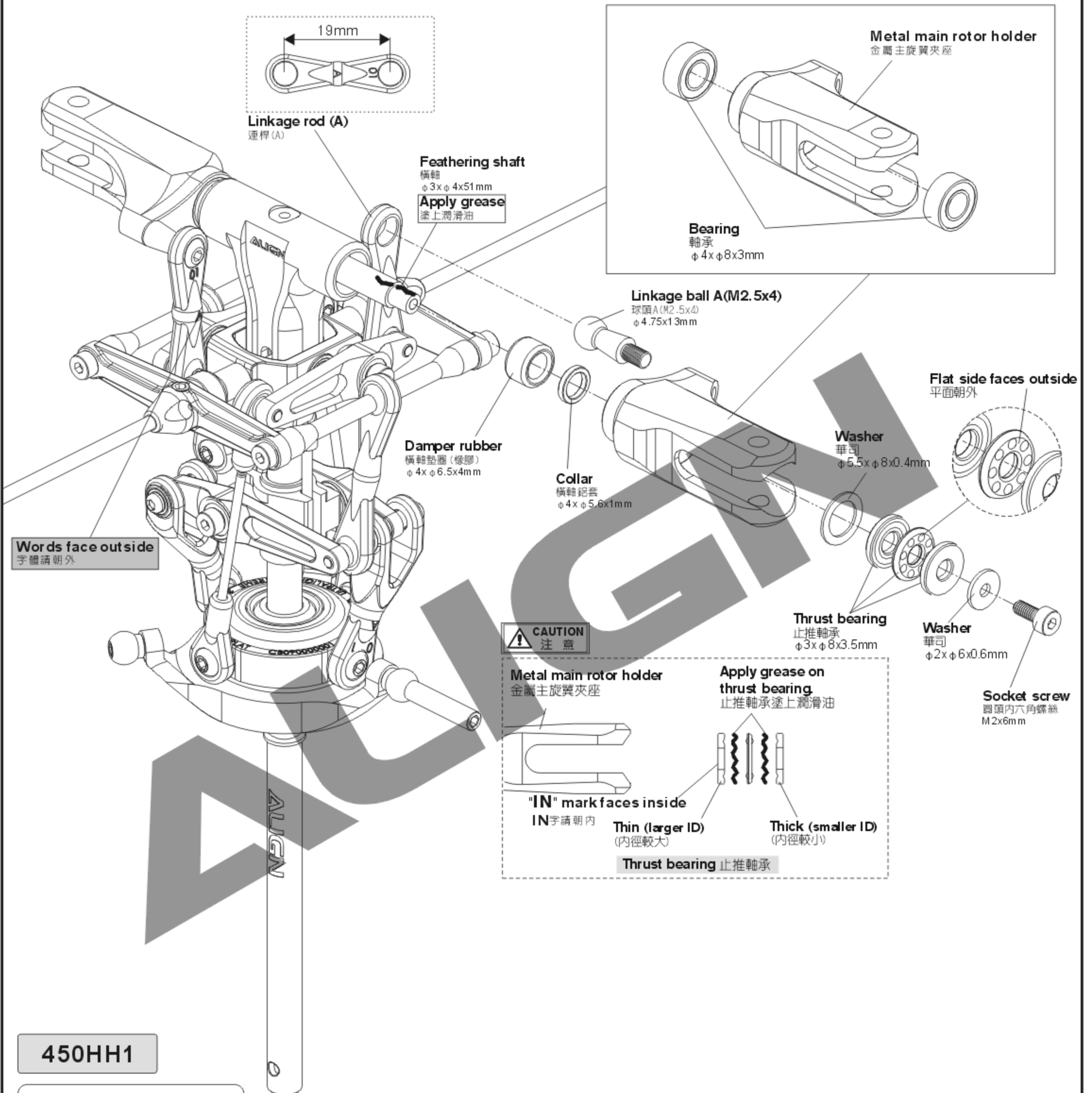

When tightening a screw to a plastic part, please tighten it firmly, but not over tightened, or they will strip.
螺絲鎖入塑膠件請務必注意，適當扭力鎖緊即可，而過緊的扭力可能會導致滑牙。

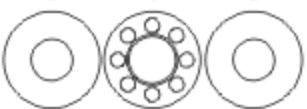

 **Apply a little amount of T43 thread lock when fixing a metal part.**
螺絲鎖附於金屬件請使用適量T43(螺絲膠)



450HH1

-  **Linkage ball A(M2.5x4)**
球頭A(M2.5x4)(φ4.75x13mm) x 2
-  **Washer**
華司(φ5.5xφ8x0.4mm) x 2
-  **Linkage rod (A)**
運桿(A) x 2
-  **Thrust bearing**
止推軸承(φ3xφ8x3.5mm) x 2
-  **Socket screw**
圓頭內六角螺絲(M2x6mm) x 2
-  **Damper rubber**
橫軸墊圈(橡膠)(φ4xφ6.5x4mm) x 2
-  **Bearing**
軸承(φ4xφ8x3mm) x 4
-  **Washer**
華司(φ2xφ6x0.6mm) x 2
-  **Collar**
橫軸鋁套(φ4xφ5.6x1mm) x 2

CAUTION 注意

When tightening a screw to a plastic part, please tighten it firmly, but not over tightened, or they will strip.
螺絲鎖入塑膠件請務必注意，適當扭力鎖緊即可，而過緊的扭力可能會導致滑牙。

For original manufactory package, if the product is already assembled by Factory, please check again if screws are firmly secured and applied with some glue.
原廠零件出廠包裝如果是組裝品，請需再確認各螺絲是否鎖緊上膠。

Apply a little amount of T43 thread lock when fixing a metal part.
 螺絲鎖附於金屬件請使用適量T43(螺絲膠)

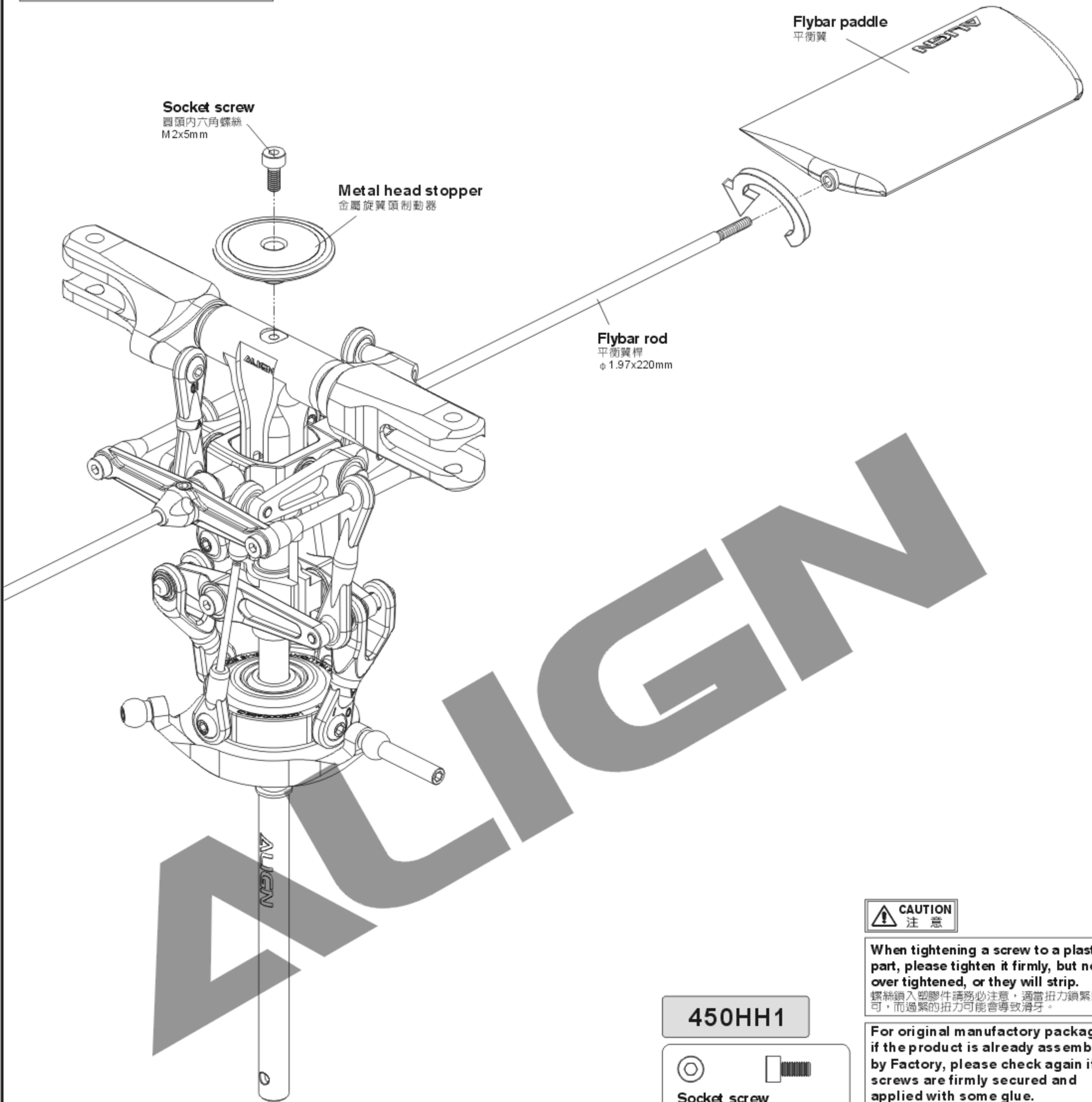

CAUTION
 注意

When tightening a screw to a plastic part, please tighten it firmly, but not over tightened, or they will strip.
 螺絲鎖入塑膠件請務必注意，適當扭力鎖緊即可，而過緊的扭力可能會導致滑牙。

450HH1

 
Socket screw
 圓頭內六角螺絲(M2x5mm) x 1

For original manufactory package, if the product is already assembled by Factory, please check again if screws are firmly secured and applied with some glue.
 原廠零件出廠包裝如果是組裝品，請再確認各螺絲是否鎖緊上膠。

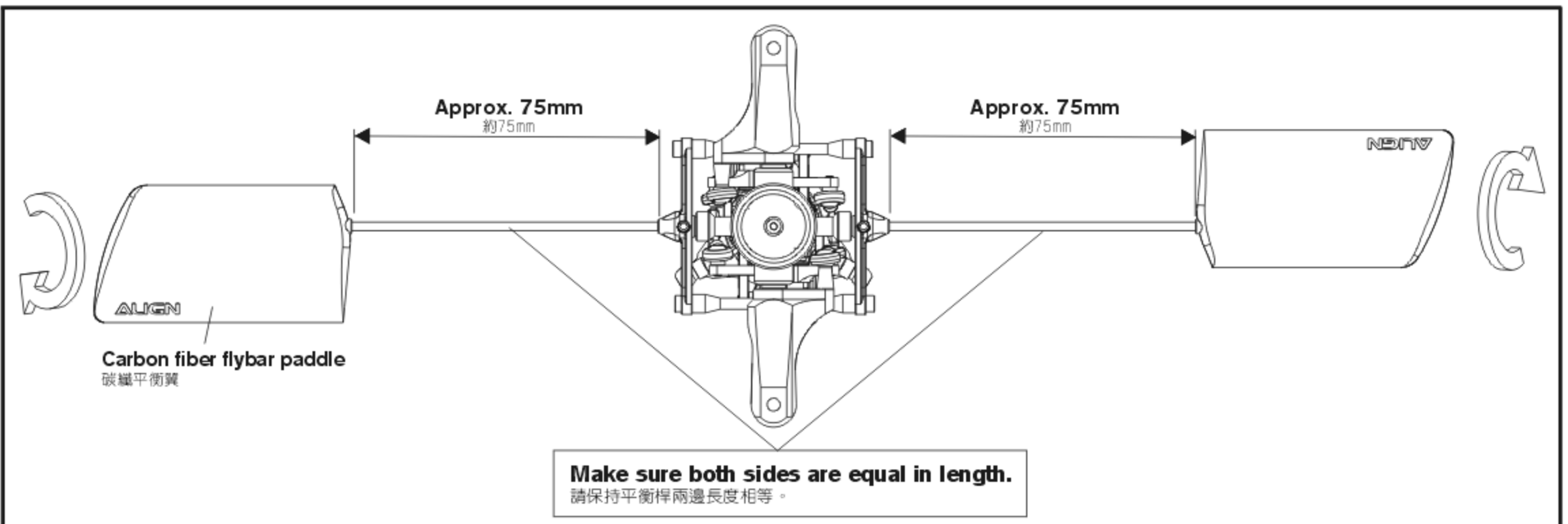

Apply a little amount of T43 thread lock when fixing a metal part.
螺絲鎖附於金屬件請使用適量T43(螺絲膠)

Socket button head screw
半圓頭內六角螺絲
M2x6mm

Washer
華司
φ 2xφ 6x0.6mm

Option 另購:
DS4 Servo horn
DS4伺服臂

Linkage ball A(M2x3.5)
球頭A(M2x3.5)
φ 4.75x8.18mm

Bearing
軸承
φ 5x φ 11x5mm

450HB1

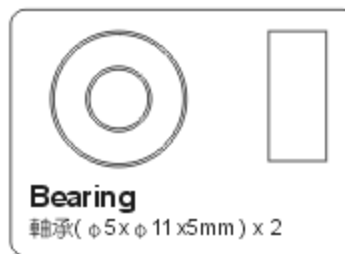

Bearing
軸承(φ 5x φ 11x5mm) x 2

450HZ2



Linkage ball A(M2x3.5)
球頭A(M2x3.5)(φ 4.75x8.18mm) x 3

M2 Nut
M2螺帽 x 3

Socket button head screw
半圓頭內六角螺絲(M2x6mm) x 6

Washer
華司(φ 2xφ 6x0.6mm) x 6

Metal bearing holder
金屬主軸固定座

M2 Nut
M2螺帽

Linkage ball A(M2x3.5)
球頭A(M2x3.5)
φ 4.75x8.18mm

Option 另購:

DS410M Digital Servo:

1. Stall torque/輸出扭力: 1.8kg.cm(4.8V)
2.2kg.cm(6.0V)
2. Motion speed/動作速度: 0.13sec/60°(4.8V)
0.09sec/60°(6.0V)
3. Dimension/尺寸: 22.8 x 12 x 25.4mm
4. Weight/重量: 13.3g

450HB1



Socket button head screw
半圓頭內六角螺絲(M2.5x5mm) x 9

Socket button head screw
半圓頭內六角螺絲(M2.5x10mm) x 2

Washer
華司(φ 2.6xφ 5.8x0.6mm) x 3

Carbon fiber main frame
碳纖主體側板
1.2m

Motor mount
馬達固定座

Skid mount
腳架固定座

Carbon fiber bottom plate
碳纖主體底板

Washer
華司
φ 2.6x φ 5.8x0.6mm

Socket button head screw
半圓頭內六角螺絲
M2.5x5mm

Socket button head screw
半圓頭內六角螺絲
M2.5x5mm

Landing skid
腳架

Washer
華司
φ 2.6x φ 5.8x0.6mm

Socket button head screw
半圓頭內六角螺絲
M2.5x10mm

Main frame assembly point:

First do not fully tighten the screws of main frames.
Put the main shaft through the two bearings and check if the movements (up/down) are smooth. The bottom bracket must be firmly touched the level table top (glass surface); please keep the smooth movements on main shaft and level bottom bracket, then slowly tighten the screws. A correct assembly can help for the power and flight performance.

機身側板組立重點:
側板螺絲先不完全鎖緊,放入主軸貫穿二顆軸承確認上下移動必需滑順,主體底板必須與水平桌面(玻璃平面)踏實緊貼;請保持主軸滑順與底板平行桌面後慢慢鎖緊螺絲。正確側板的組裝對動力與飛行性能有顯著幫助。

Main shaft
主軸

Press two main frames equally.
平均下壓兩側板下緣

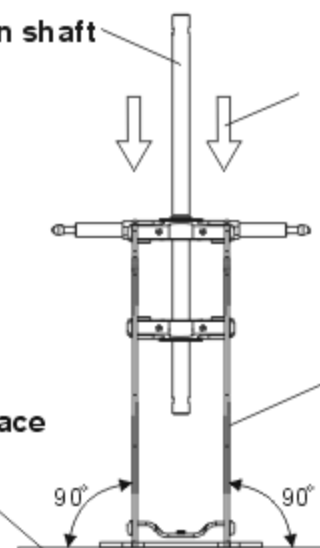

Glass surface
玻璃平面

Main frame
主身側板



Apply a little amount of T43 thread lock when fixing a metal part.
螺絲鎖附於金屬件請使用適量T43(螺絲膠)

450HB1

-  
Socket button head screw
半圓頭內六角螺絲(M2.5x5mm) x 10
-  
Socket button head self tapping screw
半圓頭內六角自攻螺絲(T2.6x6mm) x 8
-  
M2.5 Set screw
M2.5止洩螺絲(M2.5x12mm) x 2

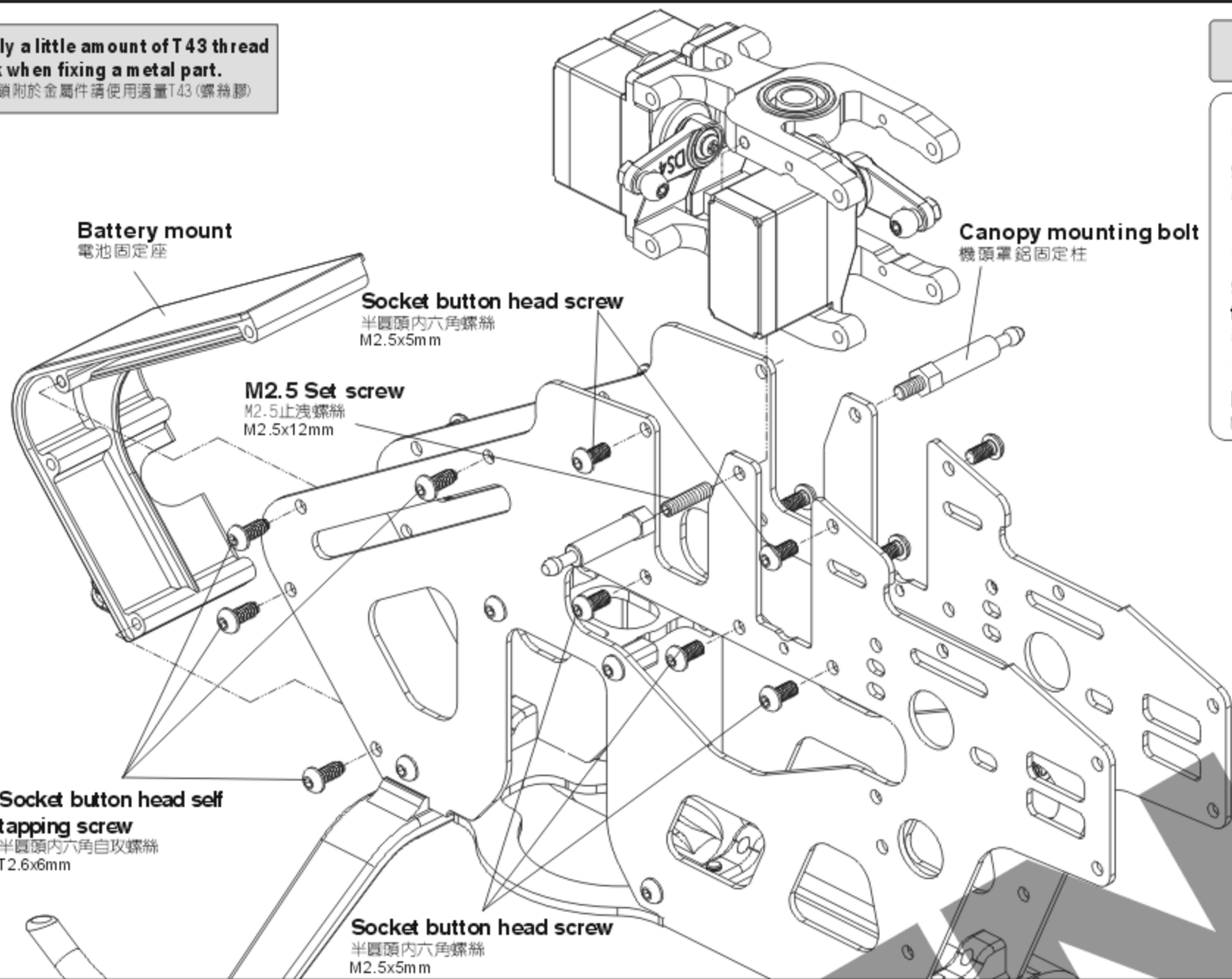

450HB1

-  
Bearing
軸承(φ3xφ8x3mm) x 2
-  
Bearing
軸承(φ6xφ10x3mm) x 2

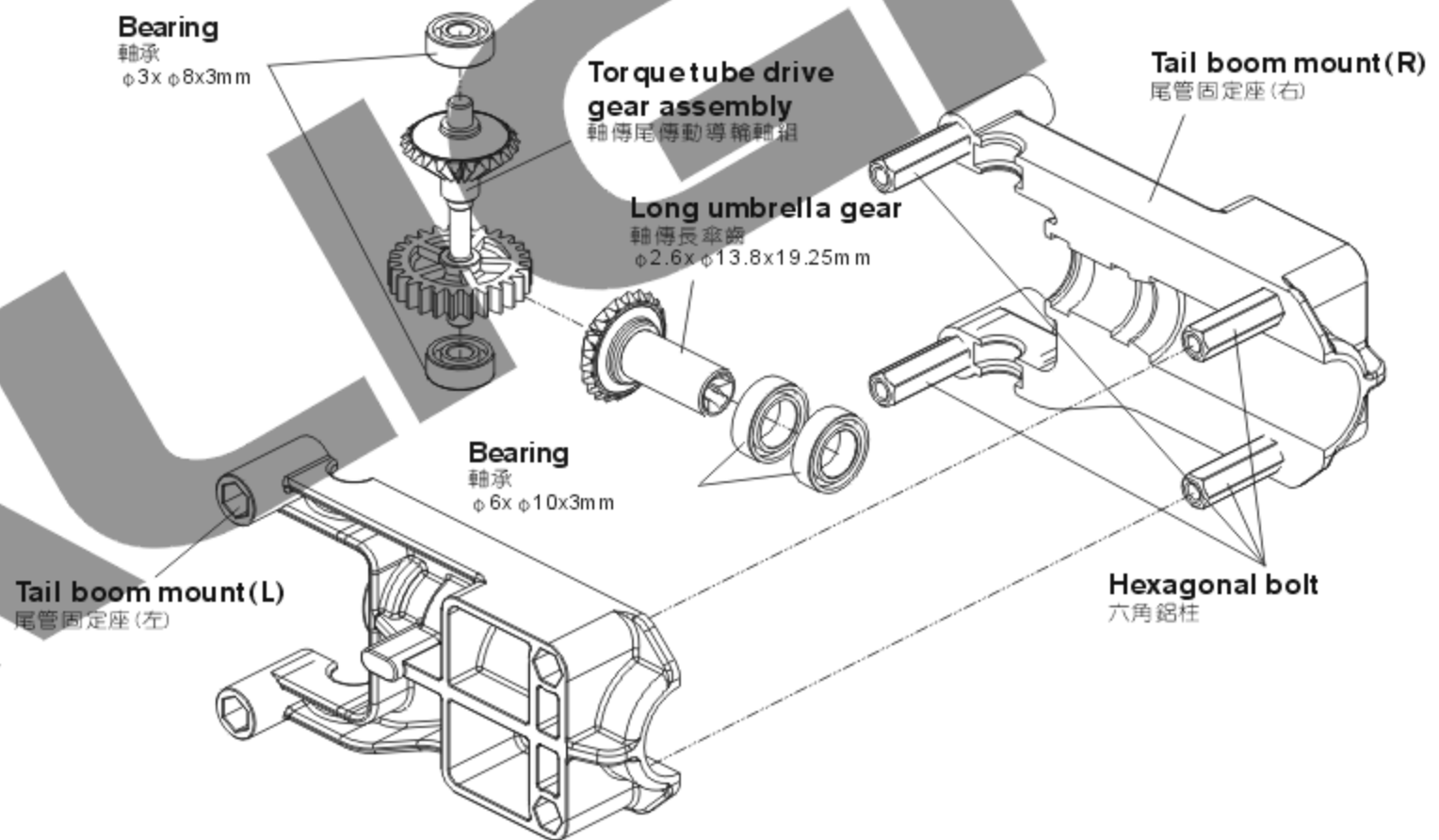





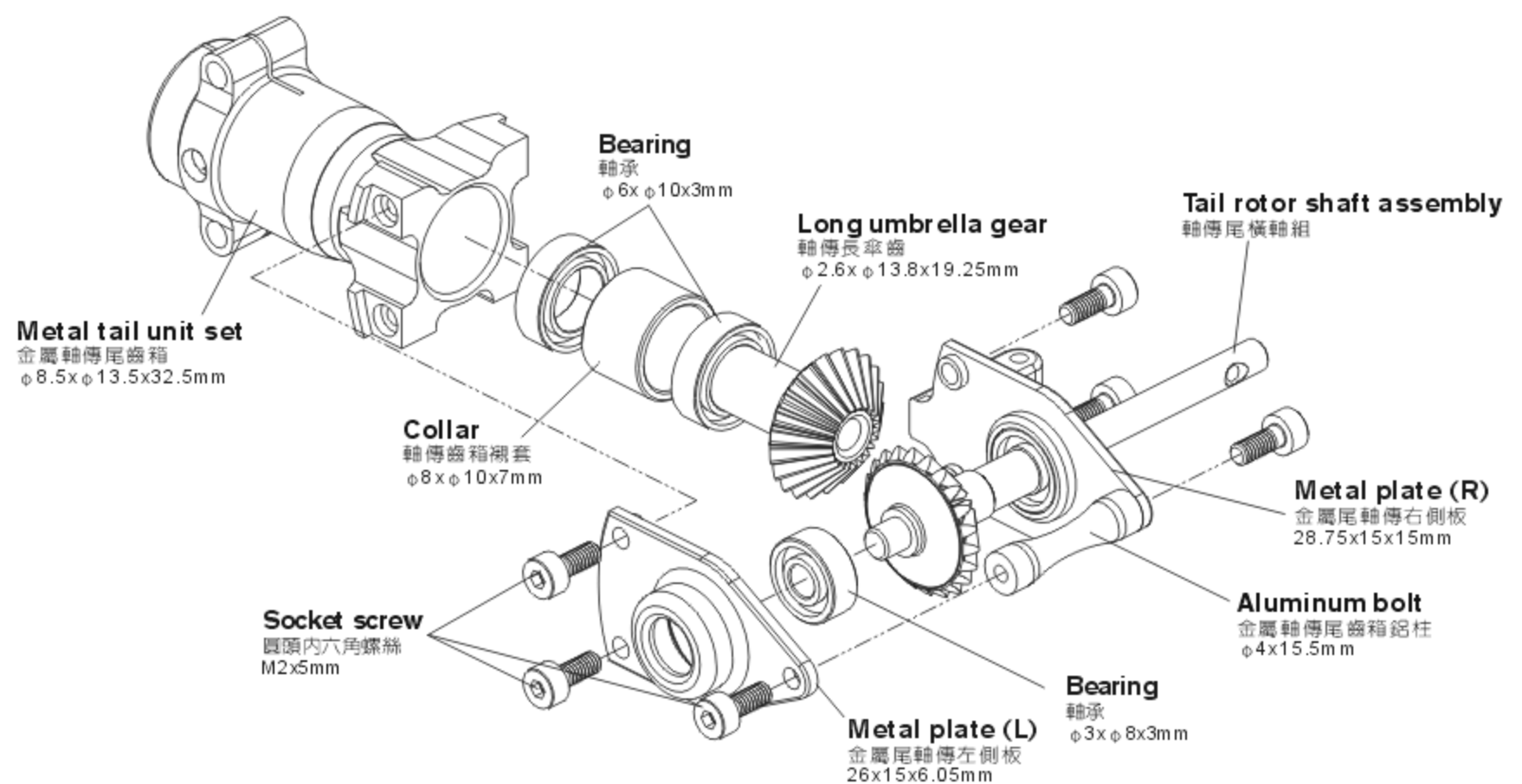











450HT1

-  
Bearing
軸承(φ3xφ8x3mm) x 2
-  
Bearing
軸承(φ6xφ10x3mm) x 2
-  
Socket screw
圓頭內六角螺絲(M2x5mm) x 6



450HT 1

- | | |
|--|--|
|  Collar screw
軸套螺絲(M2x6mm) x 2 |  Bearing
軸承(φ2xφ5x2.5mm) x 4 |
|  Collar screw
軸套螺絲(M2x8mm) x 2 |  Bearing
軸承(φ3xφ6x2.5mm) x 2 |
|  Collar screw
軸套螺絲(M2x9mm) x 1 |  Bearing
軸承(φ4xφ7x2.5mm) x 2 |
|  Socket screw
圓頭內六角螺絲(M2x8mm) x 2 |  Slide shaft
尾軸滑套 x 1 |
|  M3 Set screw
M3止洩螺絲(M3x3mm) x 1 |  Collar
尾控制組軸套座鋁襯墊(φ4xφ5.1x0.3mm) x 1 |
|  Collar A
尾連桿頂銷套A(φ2xφ3x4mm) x 2 |  Washer
華司(φ2xφ3.6x0.5mm) x 2 |
|  Collar B
尾連桿頂銷套B(φ2xφ3x3mm) x 2 |  Washer
華司(φ2xφ3.6x0.2mm) x 3 |
|  Linkage ball A(M2x3.5)
球頭A(M2x3.5)(φ4.75x8.18mm) x 1 | |
|  Linkage ball E(M2x2.5)
球頭E(M2x2.5)(φ4.75x6.3mm) x 1 | |

CAUTION
注意

Aim tail rotor hub at the concave of tail rotor shaft and fix it, please apply a little glue on the set screw.
尾旋翼T型座對準尾橫軸的凹刻並鎖上，請確認止洩螺絲上膠。

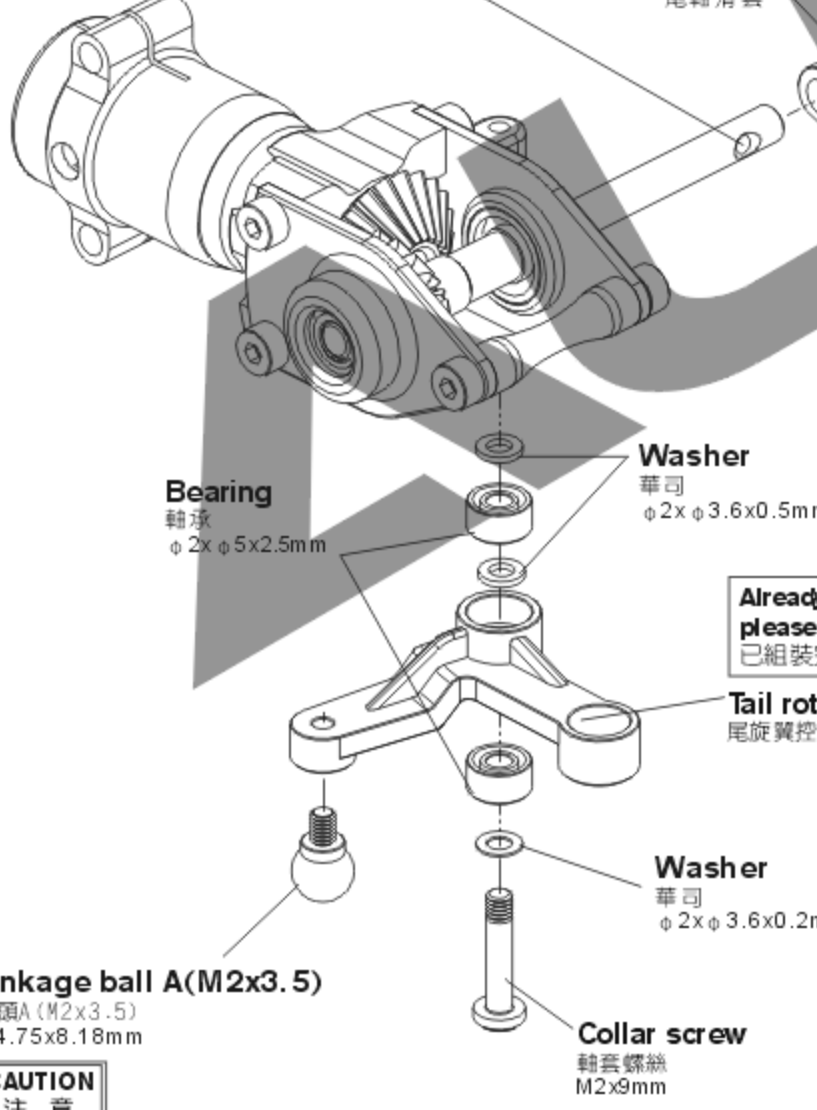

Bearing
軸承
φ4xφ7x2.5mm

Bearing holder
尾翼控制組軸承套座

Slide shaft
尾軸滑套

Linkage ball E(M2x2.5)
球頭E(M2x2.5)
φ4.75x6.3mm

Washer
華司
φ2xφ3.6x0.5mm

Already assembled by factory, please note to check again.
已組裝完成，請務必自行再確認。

Tail rotor control arm
尾旋翼控制臂

Washer
華司
φ2xφ3.6x0.2mm

Linkage ball A(M2x3.5)
球頭A(M2x3.5)
φ4.75x8.18mm

Collar screw
軸套螺絲
M2x9mm

CAUTION
注意

When tightening a linkage ball to a plastic part, please note to use a little CA glue and tighten it firmly, but not over tightened, or they will strip.
球頭鎖入塑膠件請務必注意，使用少量CA膠並適當扭力鎖緊即可，而過緊的扭力可能會導致滑牙。

When tightening a screw to a plastic part, please tighten it firmly, but not over tightened, or they will strip.
螺絲鎖入塑膠件請務必注意，適當扭力鎖緊即可，而過緊的扭力可能會導致滑牙。

For original manufactory package, if the product is already assembled by Factory, please check again if screws are firmly secured and applied with some glue.
原廠零件出廠包裝如果是組裝品，請需再確認各螺絲是否鎖緊上膠。

Care must be taken during assembly to ensure tail grips operate smoothly without binding. Any slight binding may affect tail action during flight.
組裝時，確保尾夾座滑順，些微干涉將可能導致飛行時尾動作不順暢。

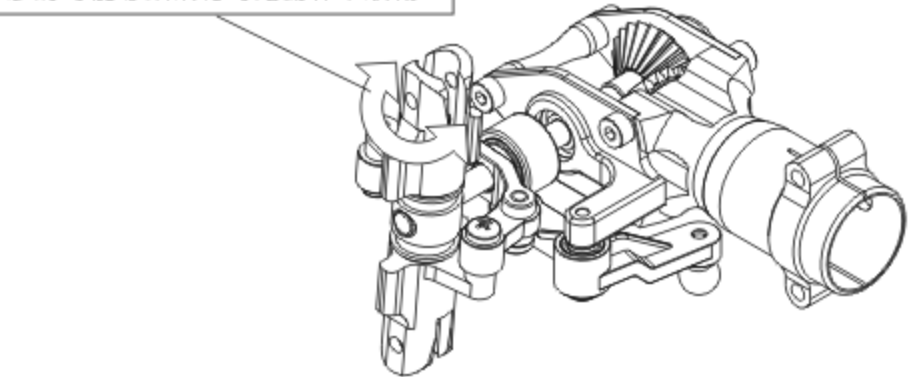

Tail pitch bell crank must be parallel to tail output shaft to ensure sufficient pitch travel range.
尾T型座與尾橫軸平齊以保持行程量足夠。

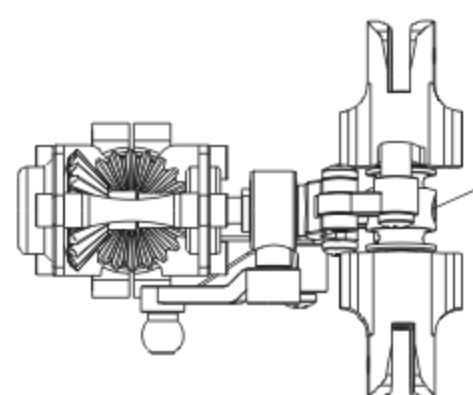

Apply a little amount of T43 thread lock when fixing a metal part.
螺絲鎖附於金屬件請使用適量T43(螺絲膠)

When assembling into the tail boom, please apply some oil on the surface, to make it smooth during the assembling and keep it vertical with the torque tube for smooth rotation.
 插入尾管內時，外表抹些潤滑油，以確保平滑壓入尾管中並與尾傳動軸保持垂直，讓尾輪傳動順暢。

Apply a little amount of T43 thread lock when fixing a metal part.
 螺絲鎖附於金屬件請使用適量T43(螺絲膠)

Already assembled by factory, please note to check again.
 已組裝完成，請務必自行再確認。

When assembling the tail boom, please aim at the fixing hole $\phi 3$.
 裝入尾管時請注意孔對準尾管 $\phi 3$ 固定孔

Before assembling, please wrap the tail boom with a scotch tape (Thickness 0.03~0.05mm) to avoid the mount slipping.
 安裝前請先用透明膠帶(0.03~0.05mm厚)包裹尾管，可防止固定座滑動。

Tip to fix the torque tube 傳動軸軸承固定位要領

Please apply some CA glue to fix MR84ZZ bearing on the torque tube, avoid CA glue adhering to the dust cover or it may cause the bearing stuck. When assembling into the tail boom, please apply some oil on the bearing holder and press the holder into the tail boom horizontally.
 請以少量CA將MR84ZZ軸承固定於尾傳動軸上，避免CA沾到軸承的防塵蓋而導致軸承卡死，插入尾管內時，尾傳動軸承座圈外表抹些潤滑油，將尾傳動軸承座圈平行壓入尾管中不可歪斜。

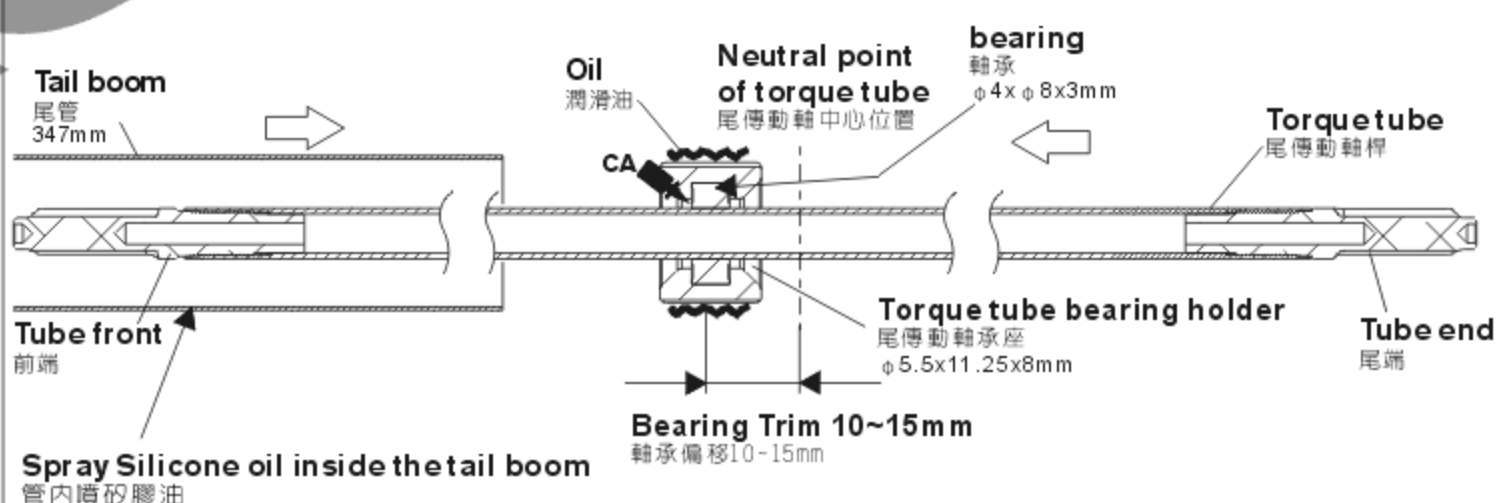

450HT 1

- Collar screw
軸套螺絲(M2x8mm) x 2

450HT 3

- Socket screw
圓頭內六角螺絲(M2x12mm) x 2
- Socket screw
圓頭內六角螺絲(M2x18mm) x 2
- Socket button head screw
半圓頭內六角螺絲(M2.5x6mm) x 2

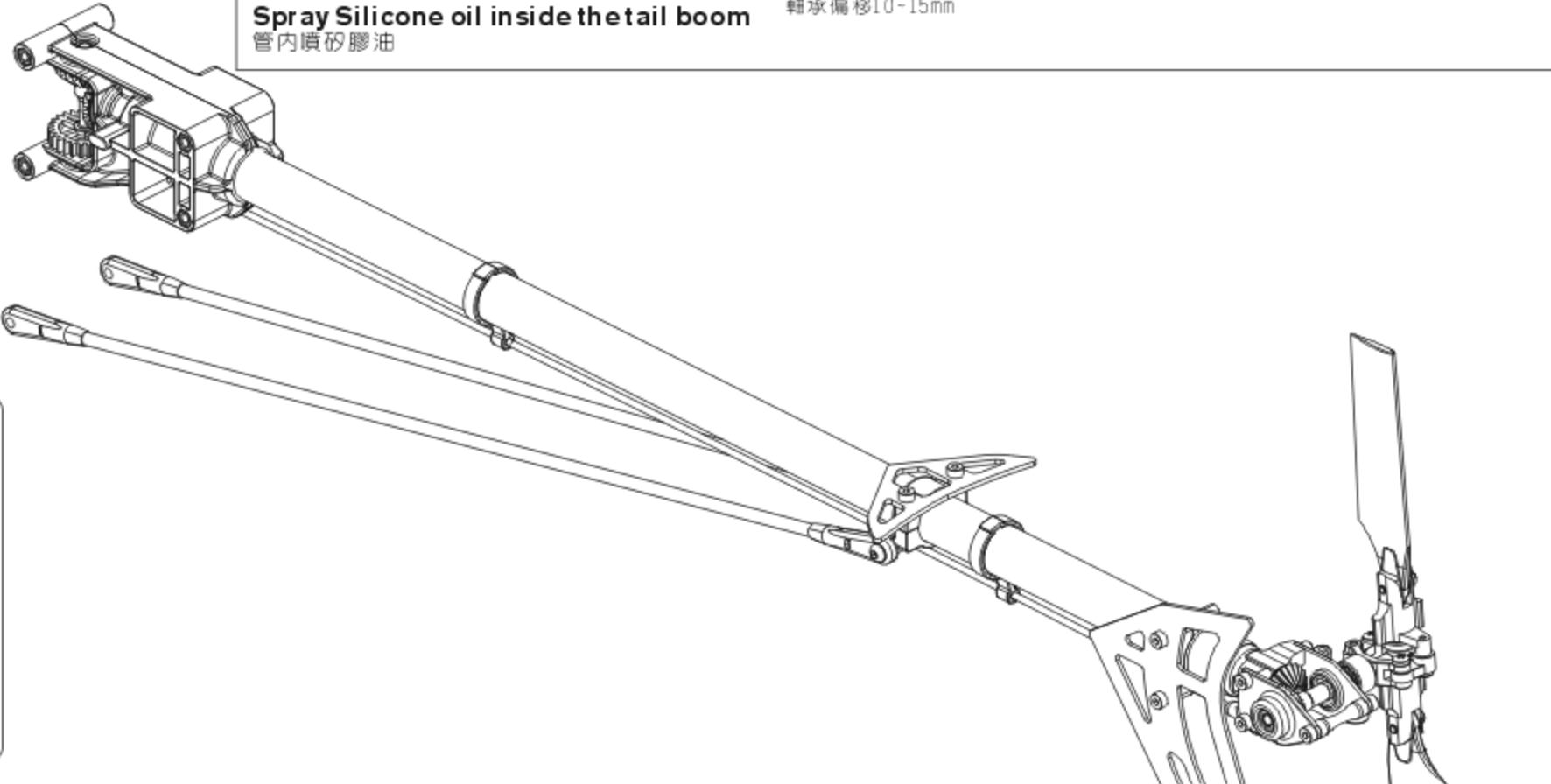

450HB1



Socket button head screw
半圓頭內六角螺絲(M2.5x5mm) x 8

450HT3



Socket button head screw
半圓頭內六角螺絲(M2.5x8mm) x 2

 Apply a little amount of T43 thread lock when fixing a metal part.
螺絲鎖附於金屬件請使用適量T43(螺絲膠)

 CAUTION
注意

When tightening a screw to a plastic part, please tighten it firmly, but not over tightened, or they will strip.
螺絲鎖入塑膠件請務必注意，適當扭力鎖緊即可，而過緊的扭力可能會導致滑牙。

For original manufactory package, if the product is already assembled by Factory, please check again if screws are firmly secured and applied with some glue.
原廠零件出廠包裝如果是組裝品，請需再確認各螺絲是否鎖緊上膠。

Recommend sanding the marked position with a waterproof abrasive paper(#800-1000) as below illustration to avoid the wires of electric parts to be cut.
建議於下圖色塊標示處，可使用#800-1000水砂紙打磨，可防止電子設備電線被割破。

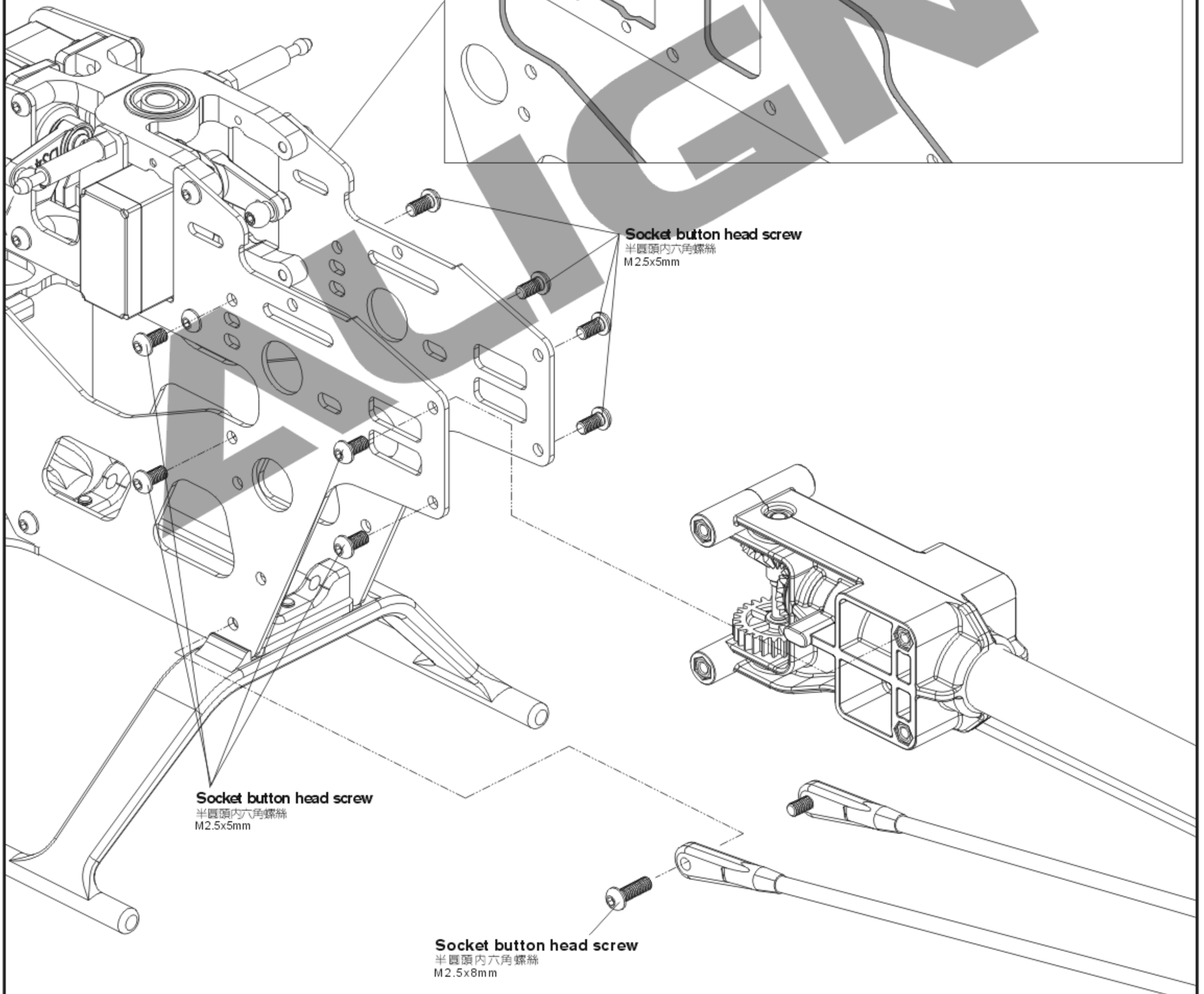
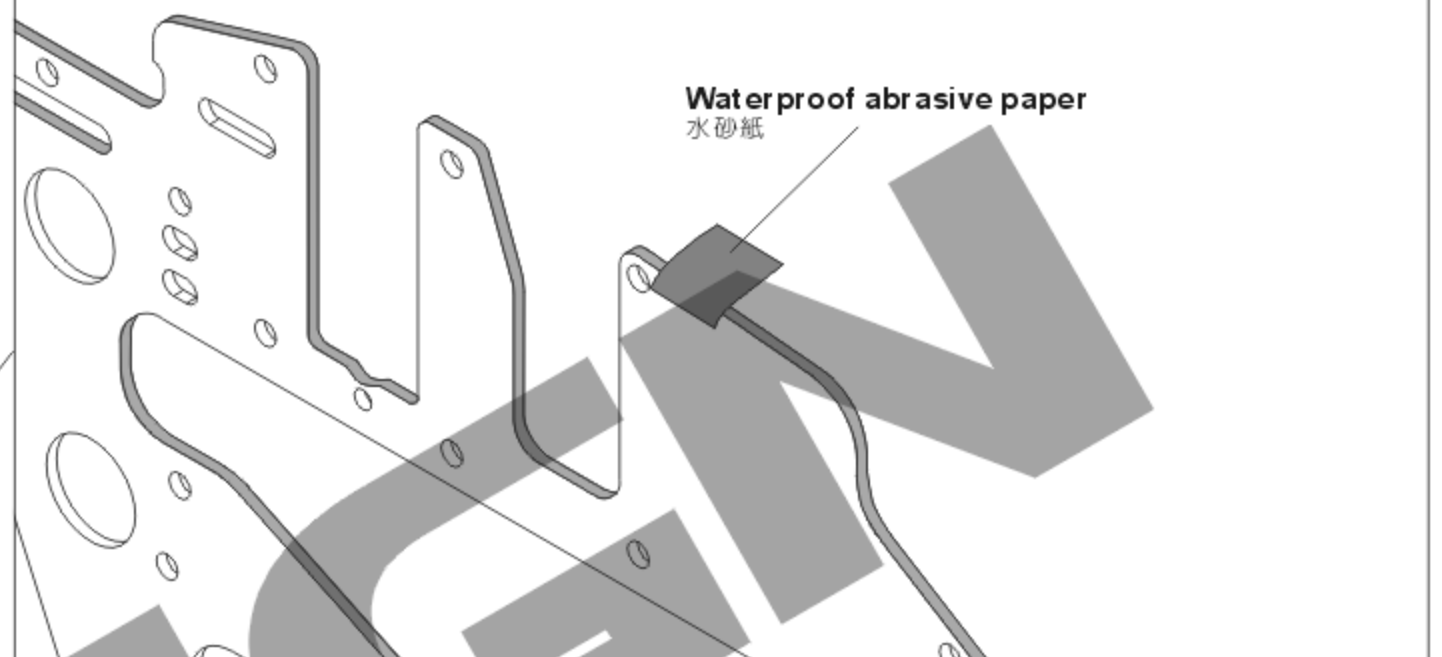

450HB1



Socket button head self tapping screw
半圓頭內六角自攻螺絲(T2.6x6mm) x 2

450HB2



Cross screw
皿頭十字螺絲(M2X4mm) x 4



Shaft ring
單向軸套圈(φ6x φ8x1.6mm) x 1



Socket collar screw
圓頭內六角軸套螺絲(M2x12mm) x 1



M2 Nut
M2螺帽 x 1

450HZ3



Main shaft spacer
主軸墊片(φ5x φ9x0.1mm) x 2

450HZ1

Linkage rod (D)
連桿(D) φ1.3x19mm x 3



Ball link
連桿頭 x 6

Apply a little amount of T43 thread lock when fixing a metal part.
螺絲鎖附於金屬件請使用適量T43(螺絲膠)



Linkage rod (D)
Approx. 31.5mm x 3
連桿(D)約31.5mm x 3

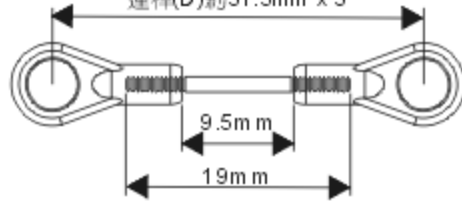

Linkage rod (D)
連桿(D)

Anti rotation bracket
十字盤導板

Main shaft spacer
主軸墊片
φ5x φ9x0.1mm

Spacer spare for gap adjustment.
間隙調整用墊片

Please do not over tighten, a over tighten may cause the autorotation tail drive gear deformed.
請以適當扭力鎖附即可，過度鎖緊易造成尾驅動主齒變形。

Main drive gear set
主齒輪組

Socket collar screw
圓頭內六角軸套螺絲
M2x12mm

Socket button head self tapping screw
半圓頭內六角自攻螺絲
T2.6x6mm

M2 Nut
M2螺帽

One-way Shaft ring
單向軸套圈
φ6x φ8x1.6mm

Cross screw
皿頭十字螺絲
M2x4mm

Main gear case
主齒中心座
φ10x φ21.5x7.8mm

Main drive gear
主齒輪
150T

One-way bearing
單向軸承
φ6x φ10x12mm

Already assembled
已裝入

Character side faces down
六角刻字面朝下

One-way bearing shaft
單向軸承套
φ5x φ6x21.5mm

OIL
潤滑油

Autorotation tail drive gear
尾驅動主齒
106T

Apply a little amount of T43 thread lock when fixing a metal part.
 螺絲鎖附於金屬件請使用適量T43(螺絲膠)

CAUTION
 注意

When tightening a screw to a plastic part, please tighten it firmly, but not over tightened, or they will strip.
 螺絲鎖入塑膠件請務必注意，適當扭力鎖緊即可，而過緊的扭力可能會導致滑牙。

For original manufactory package, if the product is already assembled by Factory, please check again if screws are firmly secured and applied with some glue.
 原廠零件出廠包裝如果是組裝品，請需再確認各螺絲是否鎖緊上膠。

450HH1

- Socket collar screw**
圓頭內六角軸套螺絲(M3x16mm) x 2
- M3 Nut**
M3防鬆螺帽 x 2

450HZ2

- M3 Set screw**
M3止洩螺絲(M3x3mm) x 1

325D Carbo fiber blade
325D碳纖維主旋翼

450HM1

- Socket screw**
圓頭內六角螺絲(M2.5x6mm) x 2
- Washer**
華司
($\phi 2.6 \times \phi 5.8 \times 0.6 \text{ mm}$) x 2

Socket collar screw
圓頭內六角軸套螺絲
M3x16mm

M3 Nut
M3防鬆螺帽

Socket screw
圓頭內六角螺絲
M2.5x6mm

For motor fixing
馬達固定螺絲

Washer
華司
 $\phi 2.6 \times \phi 5.8 \times 0.6 \text{ mm}$

Motor pinion gear 14T
馬達齒輪 14T

M3 Set screw
M3止洩螺絲
M3x3mm

Motor
馬達



Set the motor pinion gear to main drive gear mesh to approximately 0.1 mm to avoid excess power consumption or motor burnt due to overload.
 馬達前後可移動以保持兩齒輪咬合處約有0.1mm間隙，過緊齒輪咬合將造成動力損失或馬達高阻力的過載，嚴重可能導致馬達燒毀。

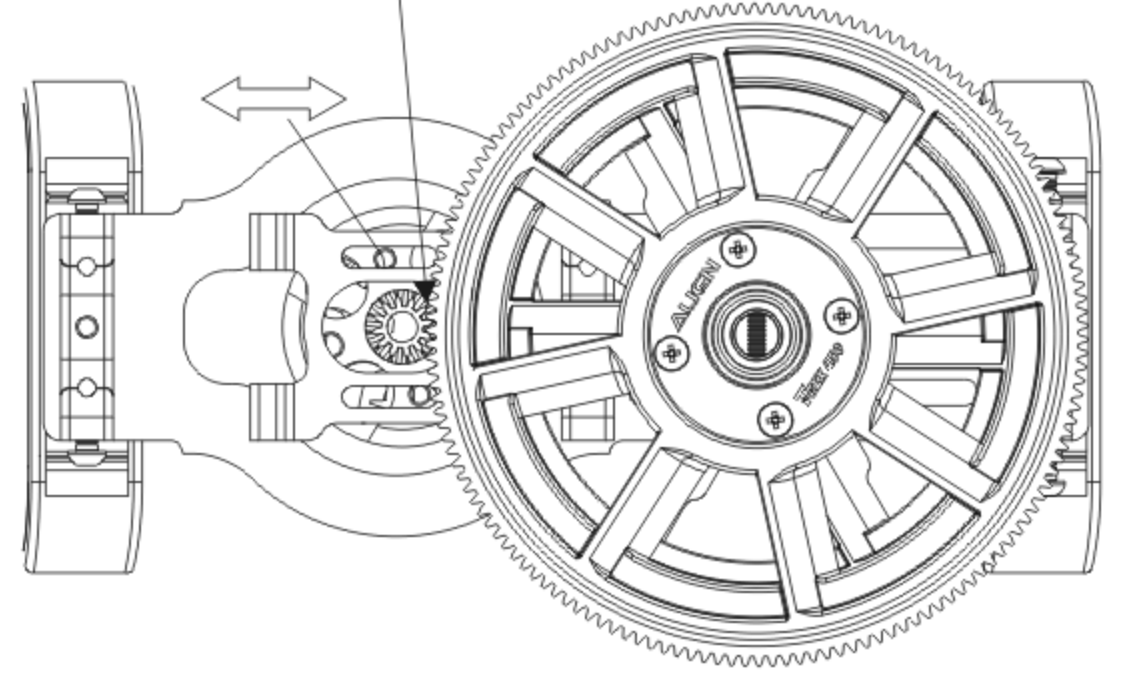

Make sure the motor pinion gear parallel (match) evenly with the main gear while assembly.
 組裝時，馬達齒輪與主齒輪平高。

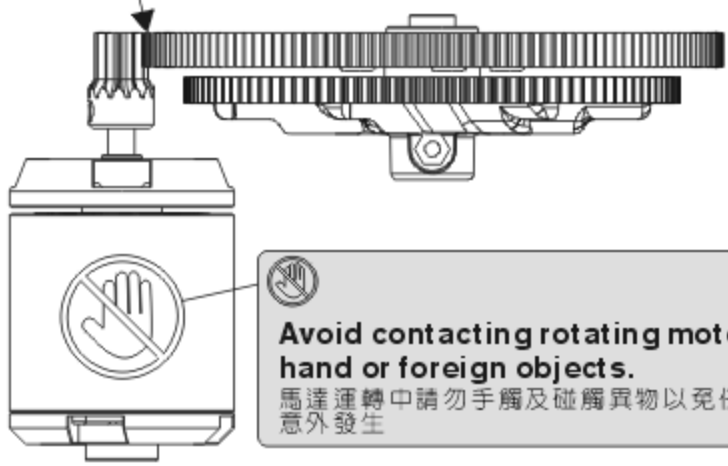

Avoid contacting rotating motor by hand or foreign objects.
 馬達運轉中請勿手觸及碰觸異物以免任何意外發生

Apply a little amount of T43 thread lock when fixing a metal part.
 螺絲鎖附於金屬件請使用適量T43(螺絲膠)

CAUTION
 注意



When tightening a screw to a plastic part, please tighten it firmly, but not over tightened, or they will strip.
 螺絲鎖入塑膠件請務必注意，適當扭力鎖緊即可，而過緊的扭力可能會導致滑牙。



For original manufactory package, if the product is already assembled by Factory, please check again if screws are firmly secured and applied with some glue.
 原廠零件出廠包裝如果是組裝品，請需再確認各螺絲是否鎖緊上膠。



450HB1



 
Socket button head self tapping screw
 半圓頭內六角自攻螺絲(T2.6x6mm) x 4

450HZ2

 
Linkage ball A(M2x3.5)
 球頭A(M2x3.5)(ϕ 4.75x8.18mm) x 1

 
M2 Nut
 M2螺帽 x 1

 
Washer
 華司(ϕ 2.6x ϕ 5.8x0.6mm) x 4

 
Socket button head self tapping screw
 半圓頭內六角自攻螺絲(T2.6x6mm) x 4

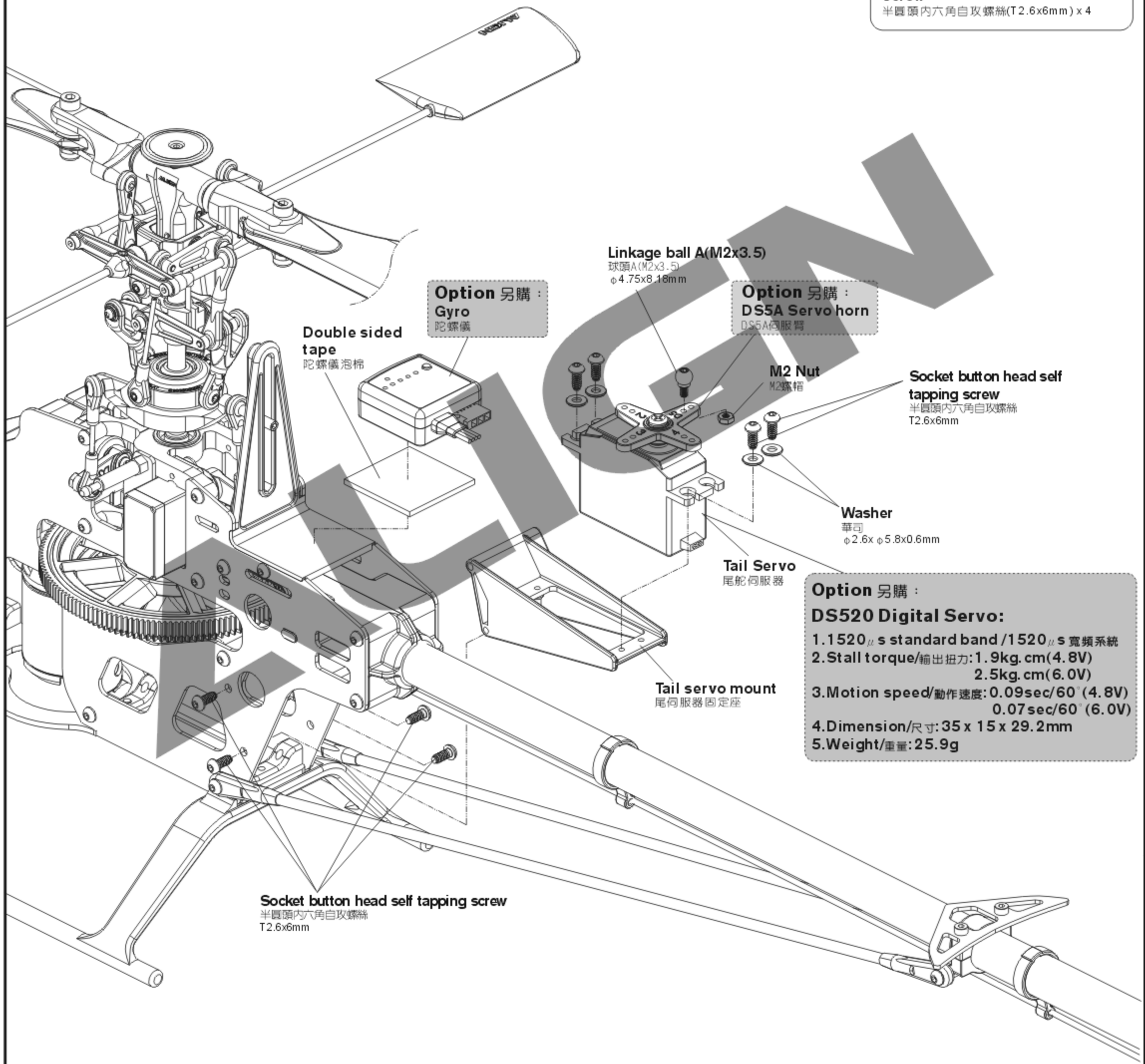

Option 另購:
 Gyro
 陀螺儀

Option 另購:
 DS5A Servo horn
 DS5A伺服臂

Option 另購:
DS520 Digital Servo:
 1. 1520 μ s standard band / 1520 μ s 寬頻系統
 2. Stall torque/輸出扭力: 1.9kg.cm(4.8V)
 2.5kg.cm(6.0V)
 3. Motion speed/動作速度: 0.09sec/60° (4.8V)
 0.07sec/60° (6.0V)
 4. Dimension/尺寸: 35 x 15 x 29.2mm
 5. Weight/重量: 25.9g

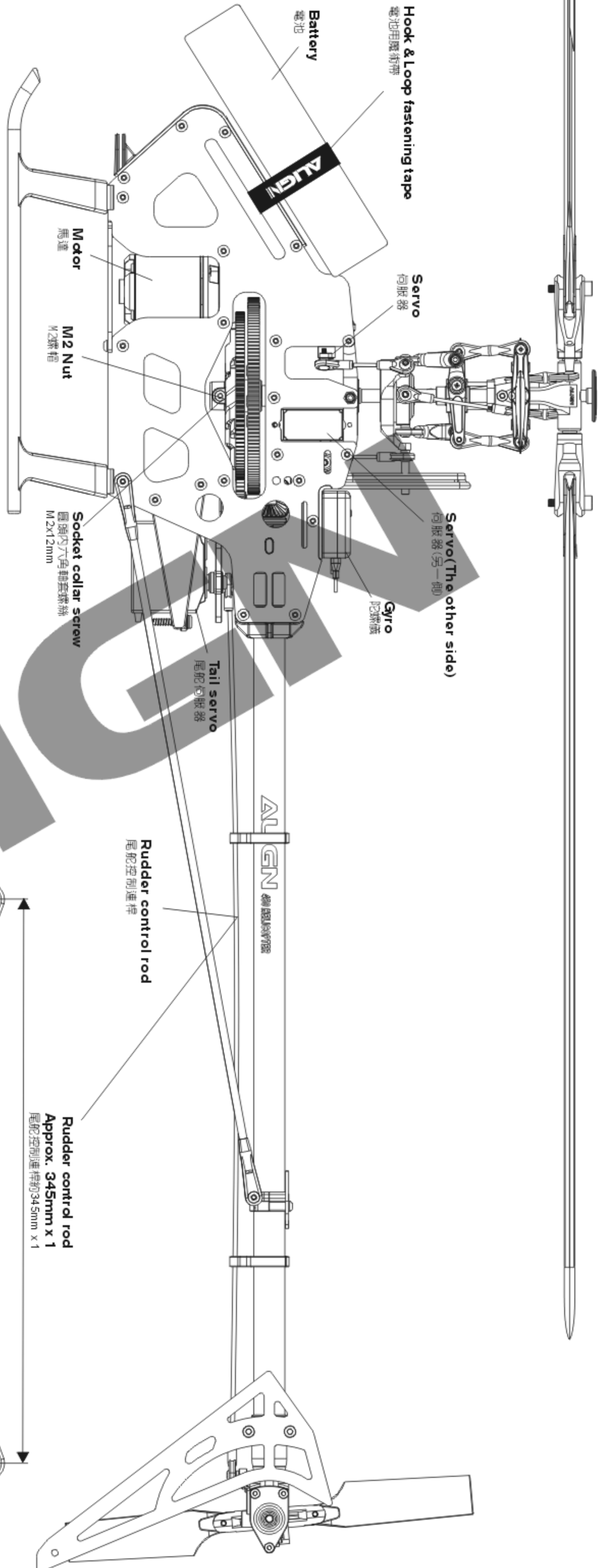

HITEC、FUTABA 6CH receiver wiring HITEC、FUTABA 6CH接收器接線示意圖

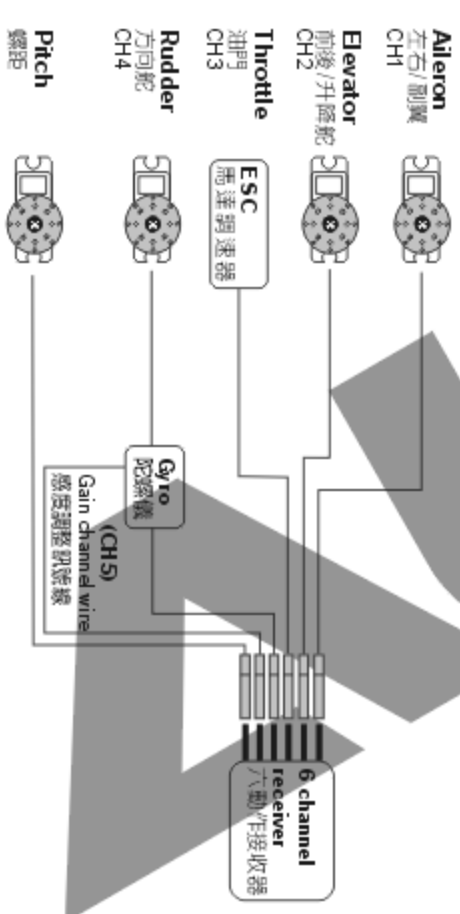

6-Channel Receiver is adequate for the requirements of the T-REX heli. You will need the following channels at a minimum: Throttle, Rudder, Elevator, Aileron, and especially Pitch(CH6) and Gyro(CH5) controls. 六動作的接收器已足夠應對T-REX遙控直升機的通道需求，除了油門、方向舵、升降舵、副翼等基本動作外，亦可以對應具備感度調整訊號線的陀螺儀(CH5)與螺距(CH6)。

JR 7CH receiver wiring JR 7CH接收器接線示意圖

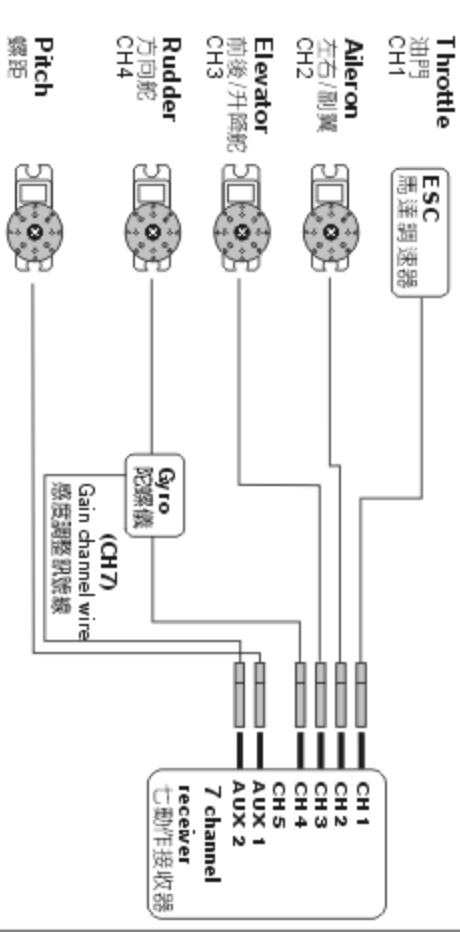

7-Channel Receiver is adequate for the requirements of the T-REX heli. You will need the following channels at a minimum: Throttle, Rudder, Elevator, Aileron, and especially Pitch(AUX 1) and Gyro(AUX 2) controls. 七動作的接收器已足夠應對T-REX遙控直升機的通道需求，除了油門、方向舵、升降舵、副翼等基本動作外，亦可以對應具備感度調整訊號線的陀螺儀(AUX 2)與螺距(AUX 1)。

Installation Method (1) 安裝方式(1)

Use attached Hoop and Loop Tape, tape the Hoop side (hooked) on the battery mounting plate and the Loop side (fuzzy) on the battery to fix the battery in order to prevent any slip.
以附贈的魔術沾膠帶，將公端的魔術沾(勾狀)黏貼於電池座上，母端的魔術沾(纖毛狀)黏貼於電池上，可有效固定電池避免滑動。

Hook and Loop Tape(fuzzy)
魔術沾母端

Hook and Loop Tape(hooked)
魔術沾公端

Use Adhesive foam or Hoop & Loop tape to fix.
以泡棉雙面膠或魔術沾固定。

NOTE: When installing the speed controller, please keep a distance at least 3cm from the receiver to avoid any interference.

注意:安裝ESC時請與接收器保持至少3cm以上的距離，避免干擾接收器。

ESC installation location (1)
ESC放置位(1)

Installation Method (2) 安裝方式(2)

NOTE: When installing the speed controller, please keep a distance at least 3cm from the receiver to avoid any interference.

注意:安裝ESC時請與接收器保持至少3cm以上的距離，避免干擾接收器。

ESC installation location (2)
ESC放置位(2)

9. CANOPY ASSEMBLY 機頭罩安裝

Canopy
機頭罩 x 1

Canopy nut
機頭罩護墊 x 2

When assembling the canopy to the unit, please completely wedge into the groove of the bottom plate.

機頭罩組裝於機體時，請完全卡入電池固定座的溝槽內。

GENERAL FLIGHT 一般飛行模式

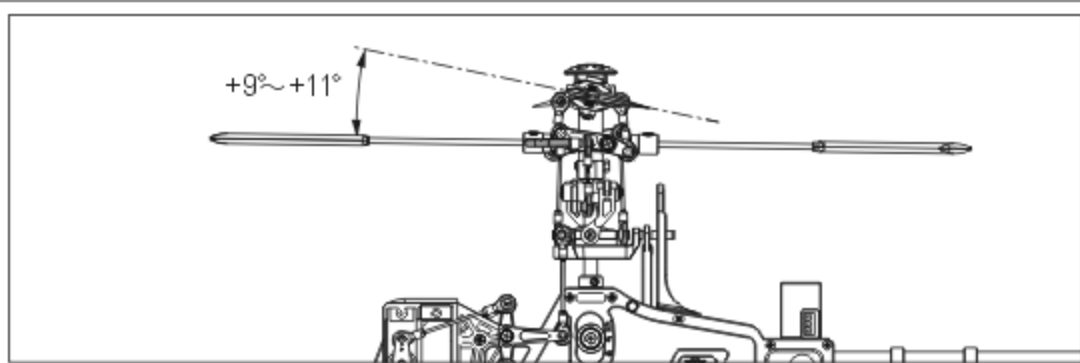

Stick position at high/Throttle 100%/Pitch +9° ~ +11°
搖桿高速/油門100%/Pitch +9° ~ +11°

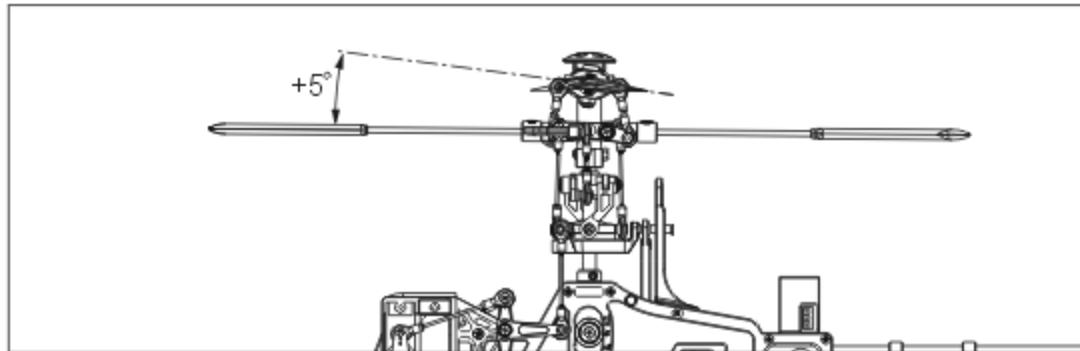

Stick position at Hovering/Throttle 60%~65%/Pitch +5°~+6°
搖桿停懸/油門60%-65%/Pitch +5°~+6°

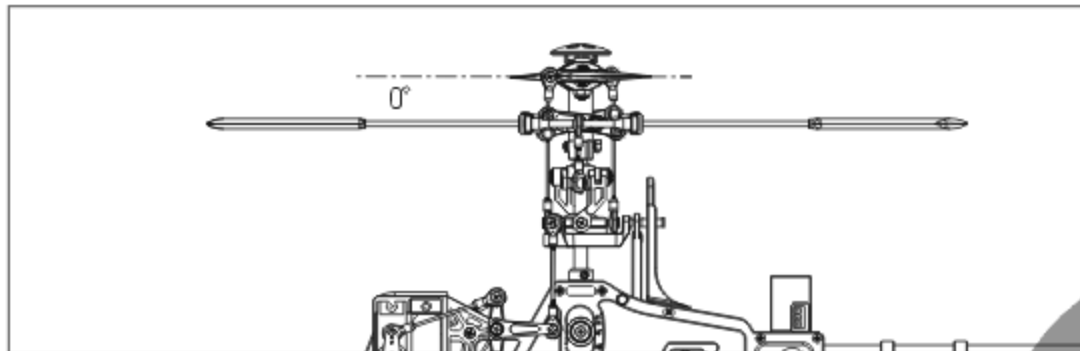

Stick position at low/Throttle 0%/Pitch 0°
搖桿低速/油門0%/Pitch 0°

GENERAL FLIGHT 一般飛行模式

	Throttle 油門	Pitch 螺距
5	100% High speed 100% 高速	+9° ~ +11°
4	85%	
3	60%~65% Hovering 60%-65% 停懸	+5°
2	40%	
1	0% Low speed 0% 低速	0°

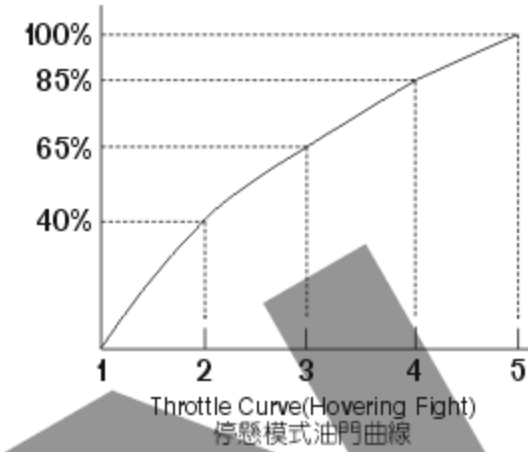

Pitch and Rotation Speed Pitch與轉速關係
TIP: It is recommended to use a lower pitch setting when using higher RPM Head speed. This will allow for better power.
 搭配要領: 如果使用較高轉速馬達動力建議搭配調低 Pitch, 將獲得較佳動力效能。

3D FLIGHT 3D特技飛行模式

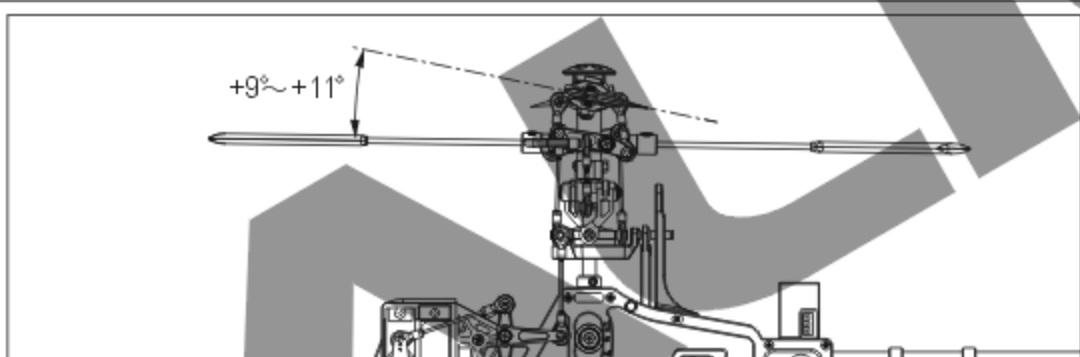

Stick position at high/Throttle 100%/Pitch +9° ~ +11°
搖桿高速/油門100%/Pitch +9° ~ +11°

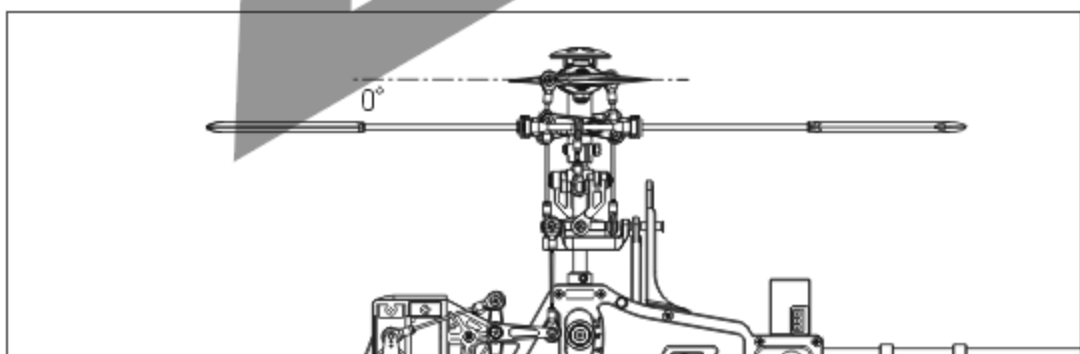

Stick position at middle/Throttle 90%/Pitch 0°
搖桿中速/油門90%/Pitch 0°

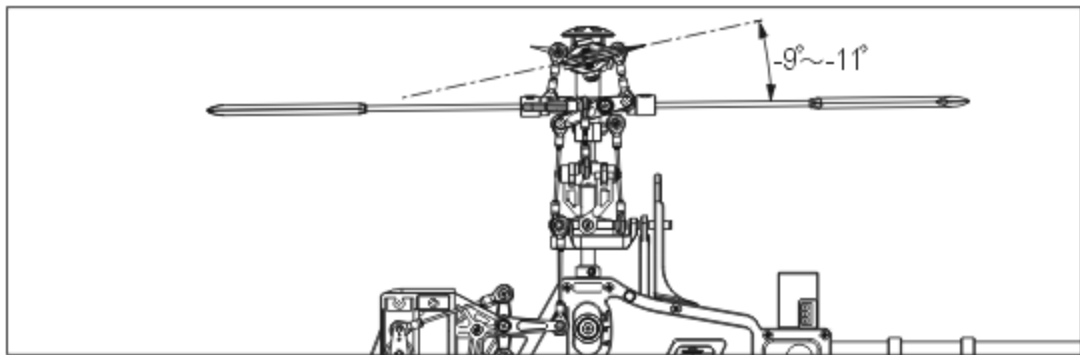

Stick position at low/Throttle 100%/Pitch -9° ~ -11°
搖桿低速/油門100%/Pitch -9° ~ -11°

IDLE 1: SPORT FLIGHT

	Throttle 油門	Pitch 螺距
5	100%	+9° ~ +11°
4	85%	
3	80%	+5°
2	85%	
1	90%	-5°

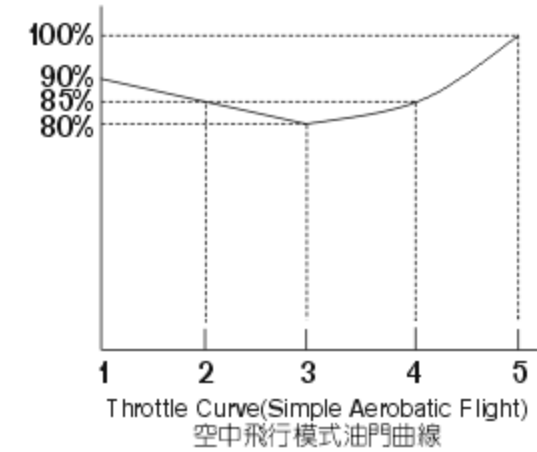

IDLE 2: 3D FLIGHT

	Throttle 油門	Pitch 螺距
5	100% High 100% 高	+9° ~ +11°
3	90% Middle 90% 中	0°
1	100% Low 100% 低	-9° ~ -11°

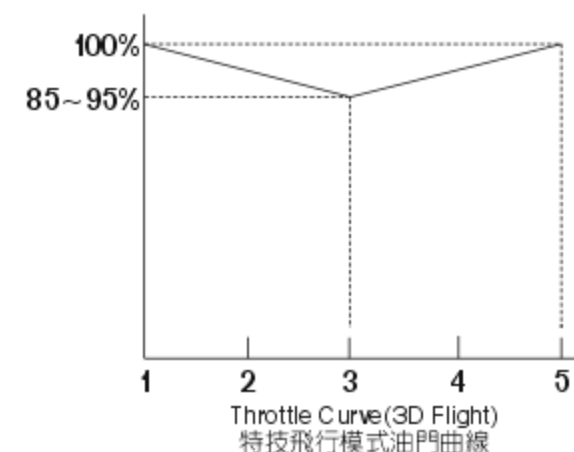

1. Pitch range: Approx. 25 degrees.
2. If the pitch is set too high, it will result in shorter flight duration and poor motor performance.
3. Setting the throttle to provide a higher speed is preferable to increasing the pitch too high.



1. 螺距 (Pitch) 總行程約 25°
2. 過大螺距設定, 會導致動力與飛行時間降低。
3. 動力提昇以較高轉速的設定方式, 優於螺距調大的設定。

Battery 電池:ALIGN Li-Poly 11.1V 2150mAh

Motor Gear 馬達齒	Main Rotor Blade 主旋翼規格	PITCH 螺距		Current(A) approx. 電流(A)大約值	Throttle Curve 油門曲線	RPM approx. 主旋翼轉速大約值
14T	325mm 3K Carbon blade 3K碳纖主旋翼	Hover停懸	+5°	10.2	0/50/65/85/100%	2650
		Idle 2	0°	13.5	100/100/100/100/100%	3660
			±9°	26.0		3280
			±11°	30.0		3180

NOTE: 1. Please use a pitch gauge to adjust the pitch value. Incorrect excess pitch setting will result poor helicopter performance and reduce ESC's life and battery's life.

註: 1. 請務必使用螺距規來量測調整螺距, 不正確的過大螺距設定不但無法發揮直昇機的特性, 反會影響到無刷調速器與電池的壽命。

14.RCE-BL35X BRUSHLESS SPEED CONTROLLER INSTRUCTION MANUAL 無刷調速器使用說明

PRODUCT FEATURES 產品特色

1. BEC output voltage (6V) shows great performance on the torque and speed of servo.
2. Three programmable throttle speed settings to support quick throttle response.
3. Include soft start and governor mode.
4. Small and compact PCB design for lightweight and simple installation.
5. Large heat sink for optimum thermal performance.
6. Highly compatible to work with 98% of all brushless motors currently on the market.
7. Ultra-smooth motor start designed to run with all kinds of brushless motors.
8. The power inlet utilizes a Japanese made "Low ESR" capacitor in order to provide stable power source.
9. The BEC power outlet utilizes a Japanese made special polymer aluminum electrolytic capacitor. It provides better noise filtering capability than other brushless ESC on the market, delivering stable performance of R/C receiver and BEC.
10. The BEC features dual TO-252 package regulators. They provide superior thermal performance with 2A peak current.
11. The throttle has more than 200 step resolution that provides great throttle response and control.

1. 6伏特BEC輸出電壓, 可將伺服器的扭力與速度完全發揮。
2. 三段可程式油門反應速度, 使動力的反應隨傳隨到。
3. 具緩啟動及Governor Mode定速功能。
4. 體積小, 窄型設計, 安裝於機身容易。
5. 有散熱片設計, 可延長電變壽命。
6. 超高相容性, 可對應市面上 98% 無刷馬達。
7. 絕佳起步設計, 無論國產、進口、內轉、外轉無刷馬達皆起步順暢。
8. 電池電源端採用日製 Low ESR 低阻抗電解電容, 大幅提高電源之穩定性。
9. BEC 端採用日製超低阻抗之鋁聚合物電容, 提供優於目前市售無刷電變之濾波抗雜訊之能力, 大幅提高接收機與 BEC 之穩定性。
10. 使用兩顆散熱良好之 TO-252 包裝之 BEC 晶體, 可達瞬間 2A 電流。
11. 油門達 200 段以上解析度, 無格數之油門感覺。

WIRING ILLUSTRATION 接線示意圖

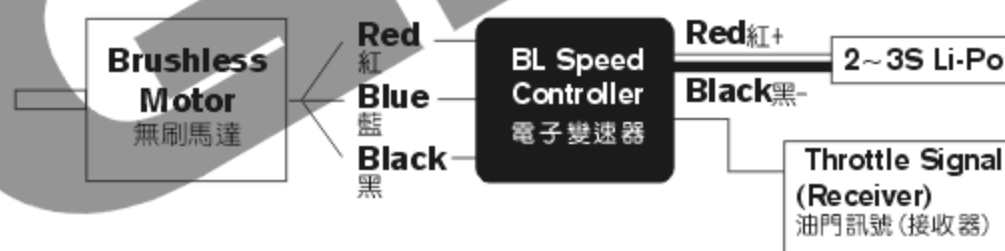

SPECIFICATION 規格

Model 型號	Continuous Current 持續	Peak Current 瞬間	BEC Output BEC輸出	Dimension 尺寸	Weight 重量
RCE-BL35X	35A	45A	2A: 2cells Lithium鋰電 / 6-7cells Ni-Mh鎳電 → 4~5 servos 3cells Lithium鋰電 / 8-9cells Ni-Mh鎳電 → 3~4 servos 4cells Lithium鋰電 / 10-12cells Ni-Mh鎳電 → 2~3 servos	45x22x12mm	25g

1. Good temperature situation for working at the maximum current
 2. Supporting motor types: 2 ~ 10 pole in/outrunner brushless motors.
 3. Supporting maximum RPM: 2 pole 190,000 rpm ; 6 pole 63,000 rpm.
 4. Input voltage: 5.5V ~ 16.8V(Lithium 2~4cells/Ni-Mh 6~12cells)
- NOTE: When setting to the Quick throttle response speed, the accelerative peak current will increase.**

1. 持續最大電流需在機體散熱良好情況下。
 2. 支援馬達型式: 二極至十數極之內外轉子無刷馬達。
 3. 輸入電壓: 5.5V~16.8V(鋰電2~4/鎳電6~12cells)。
 4. 支援最高轉速: 二極→190,000rpm; 六極→63,000rpm。
- 注意: 設定為高油門反應速度時, 加速瞬間電流會有增大情形。

FUNCTIONS 產品功能

1. Brake Option - 3 settings that include Brake disabled/Soft brake/Hard brake.
2. Electronic Timing Option - 3 settings that include Low timing/Mid timing/High timing.
Generally, 2 pole motors are recommended to use low timing, while 6 or more poles should use Mid timing. High timing gives more power at the expense of efficiency. Always check the current draw after changing the timing in order to prevent overloading of battery.
3. Battery Protection Option- 2 settings that include Li-ion, Li-poly High/Middle cutoff voltage protection.
The default setting is high cutoff voltage protection. CPU will automatically determine cell number of input Lithium battery(7.4~16.8V). This option will prevent over-discharge of the battery. The following reference is the guideline for setting the Battery Protection option.
3-1 Li-ion/Li-poly High cutoff voltage protection-When the voltage of single cell drops to 3.2V, the first step of battery protection mode will be engaged by the ESC resulting in reduced power. The pilot should reduce the throttle and prepare landing. If the voltage of single cell drops to 3.0V, the second step of battery protection mode will be engaged resulting in power cutoff. (*Note 1) For 11.1V/3cells Lithium battery, the full charged voltage will be approximately 12.6V. According to this input voltage, CPU will determine that this is a 3cell battery.
First step protection: 3.2V x 3cell=9.6V
Second step protection: 3.0V x 3cell= 9.0V
When the voltage drops to 9.6V, the power will be reduced. When the voltage drops to 9.0V, the power will be cut off.
3-2 Li-ion/Li-poly Middle cutoff voltage protection- This option is same as instruction 3-1, but when the voltage of single cell drops to 3.0V, the first step of battery protection will be engaged. When the voltage of single cell drops to 2.8V, the second step of battery protection will be engaged. (*Note 1)
Note 1: Second step of battery protection only works when Aircraft mode is setting to the option 4-1.
NOTE: THIS OPTION IS ONLY SUITABLE FOR A FULLY CHARGED BATTERY PACK IN GOOD WORKING CONDITION.

- Aircraft Option: 3 settings that include Normal Airplane / Helicopter 1 / Helicopter 2.**
Normal Airplane Mode is used for general airplanes and gliders. When flying Helicopters, you can choose Helicopter 1 Mode, or Helicopter 2 Mode. Helicopter 1 Mode provides Soft Start feature. Helicopter 2 Mode provides Soft Start and Governor Mode.
- Throttle response speed: 3 settings that include standard/ Medium/ Quick throttle response speed.**
The default setting is "quick speed". Use this option to adjust the setting according to flight character. For example, setting at Medium or Quick speed for 3D and powerful flight to make the power response more quickly, but note the accelerative peak current and power expense will increase.
- Thermal Protection: When the ESC temperature reaches 80°C for any reason, it will engage the battery protection circuit, reducing power to the ESC. We recommend mounting the ESC in a location with adequate air flow and ventilation.**
- Safe Power On Alarm: When the operator turns on the ESC, it will automatically detect the transmitter signal.**
The ESC will emit a confirmation tone and enter normal operation mode if the throttle is set to the lowest position. If the throttle position is at full throttle, it will begin to enter Setup Mode. If the throttle is in any other position, the ESC will emit an alarm and not enter into user mode for safety precautions.
- Aircraft Locator: If the aircraft should land or crash in an unexpected location and become lost, the pilot can enable the Aircraft Locator Option. The Aircraft Locator Option is engaged by turning off the transmitter. When the ESC does not receive a signal from the transmitter for 30 seconds, it will start to send an alarm to the motor. The sound of the alarm will aid the pilot to locate the aircraft. This option will not work with a PCM receiver that has SAVE function enabled, or with low noise resistant PPM receivers.**

- 煞車設定:三段選擇分為無煞車 / 軟性煞車 / 急煞車
- 進角設定:三段選擇分為低進角 / 中進角 / 高進角
設定時機分為二極以及六極以上無碳刷馬達,二極無碳刷馬達一般適用低進角,若希望馬達轉速提高,可將進角設定為中進角。六極以上無碳刷馬達一般適用中進角,若希望馬達轉速提高,可將進角設定為高進角。然而進角之調整需要注意電流之變化,避免電池過載,影響電池及馬達壽命。
- 電池保護電壓設定:二段選擇分為 Li-Ion、Li-Po高截止電壓保護/中截止電壓保護
出廠設定為高截止電壓保護;此功能會自動判定所輸入鋰電池的cell數(7.4~16.8V),並提供使用者對該電池之放電保護,以避免因放電電壓過低而造成電池損壞,以下為設定值之解說:
3-1 Li-Ion/Li-Po高截止電壓保護:當鋰電單cell壓降達3.2V時,電變會啟動第一階段保護,使動力間歇性中斷,此時使用者應將油門收小,準備降落;而當單cell電壓持續壓降達到3.0V時則會啟動第二階段保護,完全限制動力輸出(註1:僅在4-1選項"一般飛機模式"下才會啟動第二階段保護)。
例:以一個使用11.1V 3cell鋰電池之系統而言11.1V鋰電池充飽電壓約12.6V,此輸入電壓CPU會自動判定為3cell鋰電。
第一階段保護:3.2Vx3cell=9.6V 第二階段保護:3.0Vx3cell=9.0V
當電壓降至9.6V時,動力會間歇性中斷,當壓降達到9.0V時則完全限制動力輸出。
3-2 Li-Ion/Li-Po中截止電壓保護:同3-1功能說明,但單cell壓降達到3.0V時,會啟動第一階段保護,單cell壓降達到2.8V時啟動第二階段保護(註1)。
注意:以上功能僅適用於充飽電,且功能正常的鋰電池。
- 飛機模式設定:三段式選擇分為 一般飛機模式/直昇機模式1/直昇機模式2
使用於一般飛機或滑翔機時,請設定於一般飛機模式,使用於直昇機時可選擇直昇機模式1:具有緩啟動功能,或直昇機模式2:具有緩啟動及Governor Mode 定速功能。
- 油門反應速度設定:三段選擇分為標準/中速/快速
出廠設定值為"快速"油門反應速度,此功能提供使用者依所需的飛行特性來作適當的調整,例如3D飛機與劇烈的3D直昇機飛行時可設定為中速或快速,使動力反應更加快速、靈敏,但須注意提高油門反應速度時,加速瞬間電流與耗電量會有增大的情形。
- 溫度保護:當電變因不良之空氣對流或是過載輸出導致溫度上升達 80°C 時,電變會啟動溫度保護,而使動力間歇性中斷,建議將電變裝置在機艙內空氣對流之位置,並實際使用電流量表測輸出電流,以達到電變之最佳效率。
- 開機防塞衝提醒功能:當使用者開啟電變電源時,系統會自動偵測發射機之設定,如果發射機油門未置於最低點,或未置於最高點準備進入設定模式,馬達將不會轉動,同時會有警示聲響提醒。
- 尋機功能:當飛機降落在長草區無法以目視定位時,使用者可將發射機關閉,當電變無法接收來自接收機信號時,電變會於三十秒後使馬達發出警示聲響,以利定位。此功能不適用於設定了 SAVE 功能之 PCM 接收機,或抗雜訊低之 PPM 接收機。

SETUP MODE 設定模式

- Setup mode: Make sure to connect the ESC to the throttle channel of the receiver. Please refer to the user manual of your radio system. The second step is to connect the 3 power-out signal pins to the brushless motor.**
Before you turn on the transmitter, please adjust the throttle stick to the maximum full throttle position. Proceed to connect the battery to the ESC. You will hear confirmation sounds as soon as you enter the SETUP MODE.
Please refer the attached flow chart for details.
- Throttle stick positions in Setup mode: Setup mode includes five settings: Brake, Electronic Timing, Battery Protection, Aircraft, and Throttle Response Speed. Every setting has three options. Simply place the throttle stick in the highest, middle, and lowest positions for each setting. For example, first brake setting (Hard): move the stick to the highest position. Then timing setting (mid): move the throttle stick in the middle position.**

- 進入設定模式:將電變與接收器之油門 Channel 連接,不同之遙控系統請參閱您遙控系統之使用手冊,馬達之三條線亦與電變連接,將發射器之油門搖桿推到最高點,使之於全油門狀態,先開啟發射器電源,再將電源連接至電變,進入設定模式後,馬達將有設定模式之提示聲響。請參考第二頁程式化設定模式說明。
- 設定模式中之動作:設定模式共含有五項設定,分別為煞車、馬達進角、電池保護、飛機模式及油門反應速度,詳細內容請參考產品功能之解說。每一項設定中各含三段設定,各項設定以油門搖桿之上、中、下位置來決定其設定值。例如:煞車設定時,油門搖桿撥至最高,則設定為急煞車,進入第二項進角設定時,油門搖桿撥至中間,則設定為中進角。

Mode 設定模式	Throttle position 油門搖桿	Low 低	Middle 中	High 高
Brake 煞車設定		● Brake disabled(1-1) 無煞車(1-1)	Soft brake(1-2) 軟性煞車(1-2)	Hard brake(1-3) 急煞車(1-3)
Electronic Timing 進角設定		Low-timing(2-1) 低進角(2-1)	● Mid-timing(2-2) 中進角(2-2)	High-timing(2-3) 高進角(2-3)
Battery Protection 電池保護電壓設定		● High cut off voltage protection(3-1) 高截止電壓保護(3-1)	Middle cutoff voltage protection(3-2) 中截止電壓保護(3-2)	—
Aircraft 飛機模式設定		Normal Airplane/Glider(4-1) 一般飛機 / 滑翔機(4-1)	● Helicopter 1 (Soft Start)(4-2) 直昇機模式1(緩啟動功能)(4-2)	Helicopter 2 (Soft Start+ Governor Mode)(4-3) 直昇機模式2(緩啟動+Governor Mode定速功能)(4-3)
Throttle response speed 油門反應速度設定		Standard(5-1) 標準(5-1)	Medium speed(5-2) 中速(5-2)	● Quick speed(5-3) 快速(5-3)

Note: "●" default setting
註: "●" 表示出廠設定值

Chart A
表A

ESC START-UP INSTRUCTION 開機使用模式

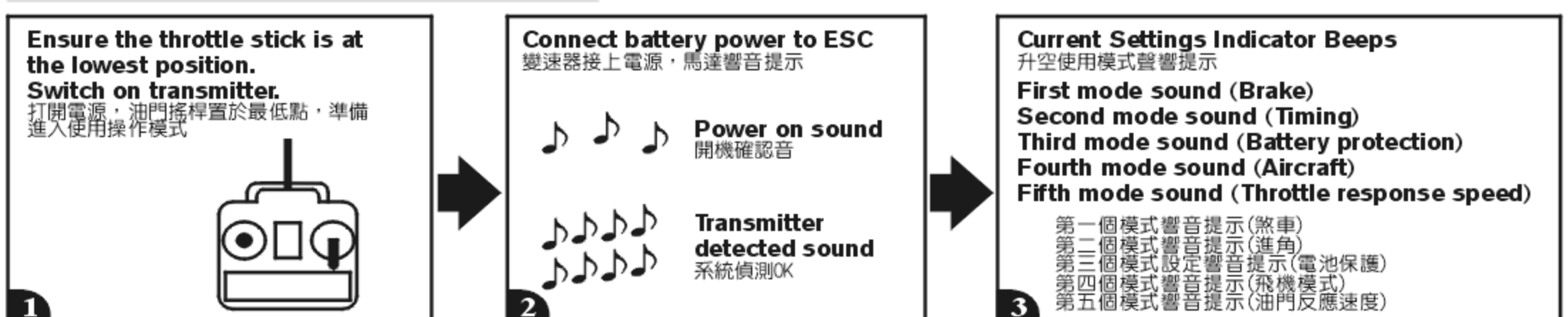

CURRENT SETTINGS INDICATOR BEEPS EXPLANATION 開機模式設定響音提示說明



First Beep Group Brake Status

第一個響音 煞車設定狀態提示

-  = Brake disabled
= 無煞車
-  = Soft brake
= 軟性煞車
-  = Hard brake
= 急煞車

Second Beep Group Electronic Timing

第二個響音 進角設定狀態提示

-  = Low timing (apply to 2 pole inrunner motors)
= 低進角(適合2級內轉子馬達)
-  = Mid timing (apply to 6 pole in/outer unner motors)
= 中進角(適合6級內外轉子馬達)
-  = High timing (apply to high power output)
= 高進角(適用於高功率輸出)

High-timing/big power/power expense

高進角模式有較大功率與耗電特性

Third Beep Group Battery protection Cutoff

第三個響音 電池保護設定狀態提示

-  = High cutoff voltage protection
= 高截止電壓保護
-  = Middle cutoff voltage protection
= 中截止電壓保護

Fourth Beep Group Aircraft Status

第四個響音 飛機模式設定狀態提示

-  = Normal airplane/Glider
= 一般飛機/滑翔機
-  = Helicopter 1 (Soft start)
= 直昇機模式1(緩啟動功能)
-  = Helicopter 2 (Soft start + Governor Mode)
= 直昇機模式2(緩啟動功能+Governor Mode定速功能)

Fifth Beep Group Throttle Response

第五個響音 油門反應速度設定狀態提示

-  = Standard
= 標準
-  = Medium speed
= 中速
-  = Quick speed
= 快速

INSTRUCTIONS ON AIRCRAFT MODE SETTINGS 飛機模式設定使用說明

Normal Airplane/Glider Mode (Option 4-1):

This option is applied to general airplanes and gliders.

Helicopter 1 Mode (Option 4-2):

This option provides a soft start feature and is applied to Helicopters for Normal, Idle Up 1, or Idle Up 2 modes.

Please note that the sensitivity of the gyro should be set lower when flying in Idle Up 1 or Idle Up 2 modes if tail hunting (wag) occurs due to higher rotor speed.

Helicopter 2 Mode (Option 4-3):

This option supports soft start as well as Governor Mode features and is applied to Helicopters for Idle Up 1 and Idle Up 2 modes(not suitable for Normal Flight Mode). When Governor Mode is in use, the throttle should be set between 75% and 85%. Again if tail wag occurs, lower the sensitivity of the gyro to eliminate the hunting effect. The Governor Mode may not work properly in cases of insufficient rotor speed (due to improper gear ratio), poor battery discharge capability, and improper setting of gyro sensitivity and the blade pitch, etc. Please make sure all the proper adjustments have been done when using Governor Mode.

一般飛機模式(選項4-1):適用於一般飛機及滑翔機。

直昇機模式1(選項4-2):具有緩啟動功能,適用於Normal、Idle1、Idle2等飛行模式,當切換至Idle1或Idle2

直昇機模式2(選項4-3):模式如有較高轉速造成陀螺儀有輕微的追蹤現象,此時應將陀螺儀的感度設定分別降低。

具有緩啟動及Governor Mode定速功能,適用於Idle1、Idle2特技飛行模式(不適合Normal飛行模式不選用),選擇定速功能時,油門應定速在75%-85%之間,如果飛行時發現有輕微的追蹤現象時,應降低陀螺儀的感度;由於轉速不足(齒比搭配不當),電池效能不佳,陀螺儀感度設定不當,Pitch設定錯誤,皆會導致無法發揮定速的功能,甚至產生尾部偏擺的情形,所以選擇此模式時應針對相關條件進行確認。

SETUP MODE 程式化設定模式

Minimum 4 channel radio is required 四動以上標準發射器均可執行設定

1 Place the throttle stick to the highest position. Switch on transmitter. 打開電源,油門搖桿置於最高點準備進入程式化功能設定模式



2 Connect battery to ESC 變速器接上電源,馬達響音提示

 Power on sound 開機確認音

 Enter Setup Mode 進入設定模式

3 Throttle channel adjustment process, the highest position acknowledge sound. 油門校正程序最高點應答音



4 Place the throttle stick to the lowest position. Position, the lowest position acknowledge sound. 油門搖桿撥到最低點確認音

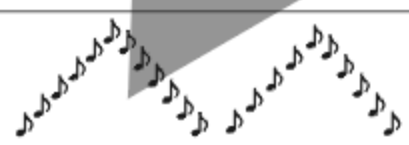

5 Use throttle stick to set preferred Brake Mode within the 5 tones. A confirmation sound will kick in when finish. 於5音節之音樂響音時以發射器油門搖桿設定,設定值請參考表A煞車設定,結束時將有連續響音確認

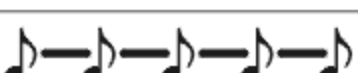

6 Use throttle stick to set preferred Timing Mode within the 5 tones. (Refer to Chart A) A confirmation sound will kick in when finish. 於5音節之音樂響音時以發射器油門搖桿設定,設定值請參考表A進角設定,結束時將有連續響音確認

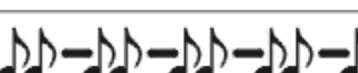

7 Use throttle stick to set preferred Battery Protection Mode within the 5 tones. (Refer to Chart A) A confirmation sound will kick in when finish. 於5音節之音樂響音時以發射器油門搖桿設定,設定值請參考表A電池保護電壓設定,結束時將有連續響音確認



8 Use throttle stick to set preferred Aircraft Mode within the 5 tones. (Refer to Chart A) A confirmation sound will kick in when finish. 於5音節之音樂響音時以發射器油門搖桿設定,設定值請參考表A飛機模式設定,結束時將有連續響音確認



9 Use throttle stick to set preferred Throttle Response Speed Mode within the 5 tones. (Refer to Chart A) A confirmation sound will kick in when finish. 於5音節之音樂響音時以發射器油門搖桿設定,設定值請參考表A油門反應速度設定,結束時將有連續響音確認



PLEASE PRACTICE SIMULATION FLIGHT BEFORE REAL FLYING 飛行前請事先熟練模擬飛行

Do a simulation flight until you familiarize your fingers with the movements of the rudders, and keep practicing until the fingers move naturally.

1. Place the helicopter in a clear open field (Make sure the power OFF) and the tail of helicopter point to yourself.
2. Practice to operate the throttle stick (as below illustration) and repeat practicing "Throttle high/low", "Aileron left/right", "Rudder left/right", and "Elevator up/down".
3. The simulation flight practice is very important, please keep practicing until the fingers move naturally when you hear operation orders being call out.
4. Another safe and effective practice method is to use the transmitter flying on the computer through simulator software sold on the market.

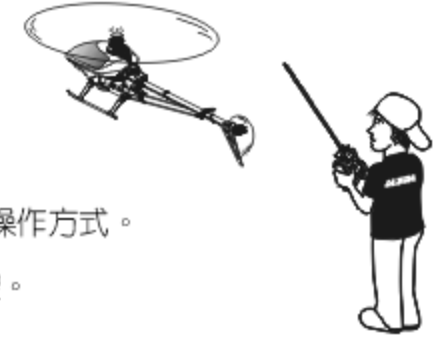

在還沒瞭解直昇機各動作的操控方式前，嚴禁通電飛行，請先進行模擬飛行的練習，並不斷的重複，直到手指可熟練的控制各個動作及方向。

1. 將直昇機放在空曠的地方(確認電源為關閉)，並將直昇機的機尾對準自己。
2. 練習操作遙控器的各搖桿(各動作的操作方式如下圖)，並反覆練習油門高/低、副翼左/右、升降舵前/後及方向舵左/右操作方式。
3. 模擬飛行的練習相當重要，請重複練習直到不需思索，手指能自然隨著喊出的指令移動控制。
4. 另外一種最有效、最安全的練習方式，就是透過市面販售的模擬軟體，以遙控器在電腦上模擬飛行，熟悉各種方向的操控。

Mode 1	Mode 2	Illustration 圖示

FLIGHT ADJUSTMENT AND NOTICE FOR BEGINNERS 初學飛行調整與注意



- ⊙ Check if the screws are firmly tightened.
- ⊙ Check if the transmitter and receivers are fully charged.
- ⊙ 再次確認→螺絲是否鎖固?
- ⊙ 發射器和接收器電池是否足夠。

★ When arriving at the flying field.
★ 當抵達飛行場

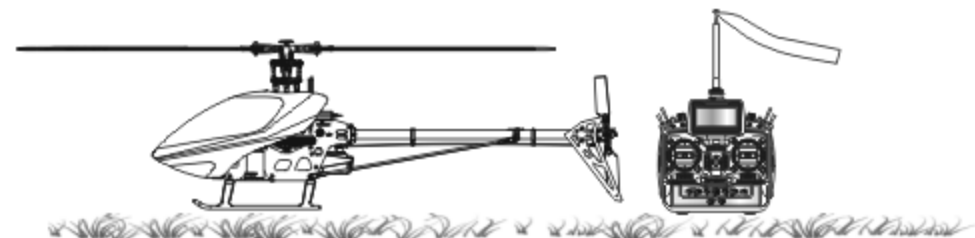

If there are other radio control aircraft at the field, make sure to check their frequencies and tell them what frequency you are using. Frequency interference can cause your model, or other models to crash and increase the risk of danger. 假使飛行場有其他遙控飛機，請確認他們的頻率，並告知他們你正在使用的頻率，相同的頻率會造成干擾導致失控和大大地增加風險。

STARTING AND STOPPING THE MOTOR 啟動和停止馬達



First check to make sure no one else is operating on the same frequency. Then place the throttle stick at lowest position and turn on the transmitter. 首先確認附近沒有其他相同頻率的使用，然後打開發射器將油門搖桿推到低點。



Check if the throttle stick is set at the lowest position. 確認油門搖桿是在最低的位置。

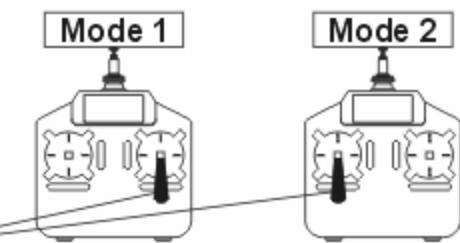

★ Check the movement.
★ 動作確認



ON! Step 1
First turn on the transmitter.
先開啟發射器

- ⊙ Are the rudders moving according to the controls?
- ⊙ Follow the transmitter's instruction manual to do a range test.
- ⊙ 方向舵是否隨著控制方向移動?
- ⊙ 根據發射器說明書進行距離測試。



ON! Step 2
Connect to the helicopter power
接上直昇機電源



OFF! Step 3
Reverse the above orders to turn off.
關閉電源時請依上述操作動作反執行。

Main rotor adjustments 主旋翼雙槳平衡調整



Tracking adjustment is very dangerous, so please keep away from the helicopter at a distance of at least 5m.
調整軌跡非常危險，請於距離飛機最少5公尺的距離。

1. Before adjusting, apply a red piece of tape on one blade, or paint a red stripe with a marker or paint to identify on blade.
2. Raise the throttle stick slowly and stop just before the helicopter lifts-off ground. Look at the spinning blades from the side of the helicopter.
3. Look at the path of the rotor carefully. If the two blades rotate in the same path, it does not need to adjustment. If one blade is higher or lower than the other blade, adjust the tracking immediately.
4. Linkage rod (C): Slight pitch trim.

1. 調整前先在其中一支主旋翼的翼端，貼上有顏色的貼紙或畫上顏色記號，方便雙槳調整辨識。

2. 慢慢的推起油門搖桿到高點並且停止，在飛機離開地面前，從飛機側邊觀察主旋翼轉動。

3. 仔細觀察旋翼軌跡(假如兩支旋翼移動都是相同軌跡，則不需要調整;可是如果一支旋翼較高或較低產生“雙槳”的情形時，則必須立刻調整軌跡)。

4. 連桿(C)為螺距微調整。

A. When rotating, the blade with higher path means the pitch too big. Please shorten pitch linkage rod (C) for regular trim.

B. When rotating, the blade with lower path means the pitch too small. Please lengthen pitch linkage rod (C) for regular trim.

A. 旋翼轉動時較高軌跡的主旋翼表示螺距(PITCH)過大，請調短連桿(C)修正。

B. 旋翼轉動時較低軌跡的主旋翼表示螺距(PITCH)過小，請調長連桿(C)修正。



Incorrect tracking may cause vibrations. Please repeat adjusting the tracking to make sure the rotor is correctly aligned. After tracking adjustment, please check the pitch angle is approx. +5~6° when hovering.

不正確的旋翼軌跡會導致震動，請不斷重複調整軌跡，使旋翼軌跡精準正確。
在調整軌跡後，確認一下Pitch角度在停旋時應為大約+5~6°。

FLIGHT ADJUSTMENT AND NOTICE FOR BEGINNERS 初學飛行調整與注意



- ◎ Make sure that no one or obstructions in the vicinity.
- ◎ You must first practice hovering for flying safety. This is a basic flight action. (Hovering means keeping the helicopter in mid air in a fixed position)
- ◎ 確認鄰近地區沒有人和障礙物。
- ◎ 為了飛行安全，你必須先練習停旋，這是飛行動作的基礎(停旋:直昇機滯留空中並保持固定位置)。
- ◎ Please stand approximately 5m diagonally behind the helicopter.
- ◎ 練習時，請站在直昇機後方5公尺。



Beginner may install a training landing gear to avoid any crash caused by offset effect while landing.

必要時初學者可以在腳架下方安裝練習架，可避免降落時因重心偏移導致主旋翼或直昇機損毀。

STEP 1 THROTTLE CONTROL PRACTICE 油門控制練習

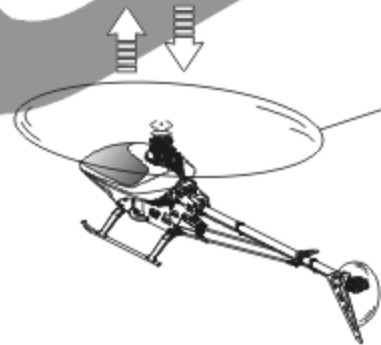
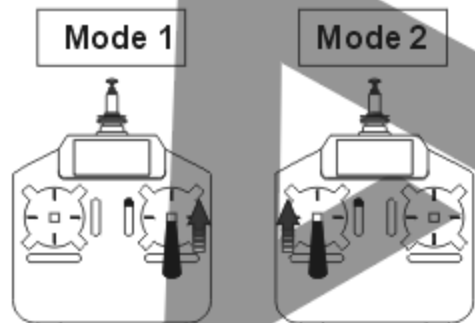

- ◎ When the helicopter begins to lift-off the ground, slowly reduce the throttle to bring the helicopter back down. Keep practicing this action until you control the throttle smoothly.

◎ 當直昇機開始離地時，慢慢降低油門將飛機降下。持續練習飛機從地面上升和下降直到你覺得油門控制很順。

STEP 2 AILERON AND ELEVATOR CONTROL PRACTICE 副翼和升降控制練習

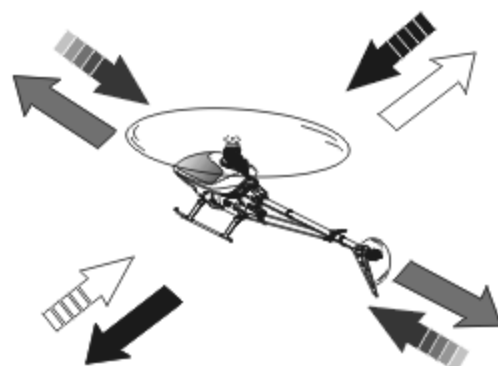
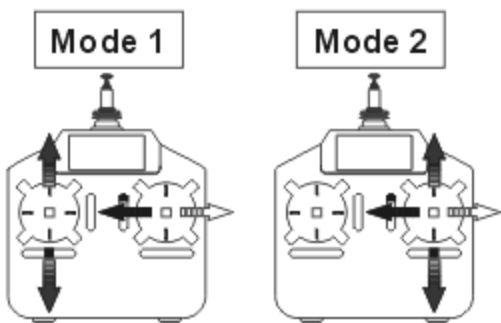

1. Raise the throttle stick slowly.
2. Move the helicopter in any direction back, forward, left and right, slowly move the aileron and elevator sticks in the opposite direction to fly back to its original position.

1. 慢慢升起油門搖桿。
2. 使直昇機依指示:移動向後/向前/向左/向右，慢慢的反向移動副翼和升降搖桿並將直昇機開回到原來位置。



- ◎ If the nose of the helicopter moves, please lower the throttle stick and land the helicopter. Then move your position diagonally behind the helicopter 5m and continue practicing.
- ◎ If the helicopter flies too far away from you, please land the helicopter and move your position behind 5m and continue practicing.

◎ 當直昇機機頭偏移時，請降低油門並且降落，然後移動自己的位置到直昇機的正後方5公尺再繼續練習。
◎ 假如直昇機飛離你太遠，請先降落直昇機，並到直昇機後5公尺再繼續練習。

STEP 3 RUDDER CONTROL PRACTICING 方向舵操作練習

1. Slowly raise the throttle stick.
2. Move the nose of the helicopter to right or left, and then slowly move the rudder stick in the opposite direction to fly back to its original position.

1. 慢慢升起油門搖桿。

2. 將直昇機機頭移動左或右，然後慢慢反向移動方向舵搖桿並將直昇機飛回原本位置。

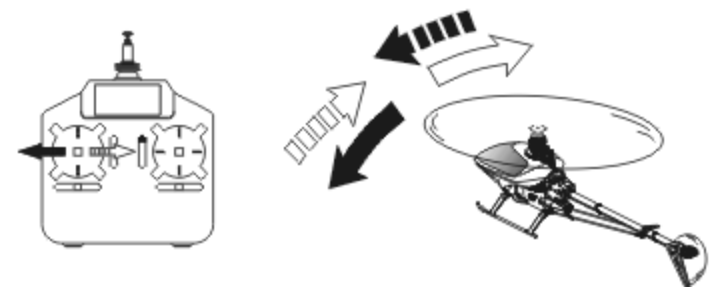

STEP 4

After you are familiar with all actions from Step1 to 3, draw a circle on the ground and practice within the circle to increase your accuracy.

當你覺得 step1-3 動作熟悉了，在地上畫圈並在這個圈圈的範圍內練習飛行，以增加你操控的準確度。

◎You can draw a smaller circle when you get more familiar with the actions.

◎當你更加習慣操作動作，你可以畫更小的圈。

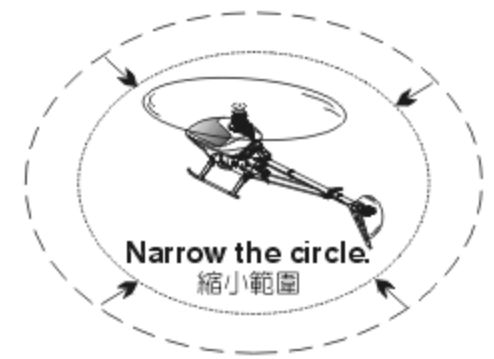

STEP 5 DIRECTION CHANGE AND HOVERING PRACTICE 改變直昇機方向和練習停旋

After you are familiar with Step1 to 4, stand at side of the helicopter and continue practicing Step1 to 4.

Then repeat the Step1 to 4 by standing right in front of the helicopter.

當你覺得step1-4動作熟悉了，站在面對直昇機側邊並繼續練習step1-4。之後，站在直昇機機頭右邊重複步驟練習。

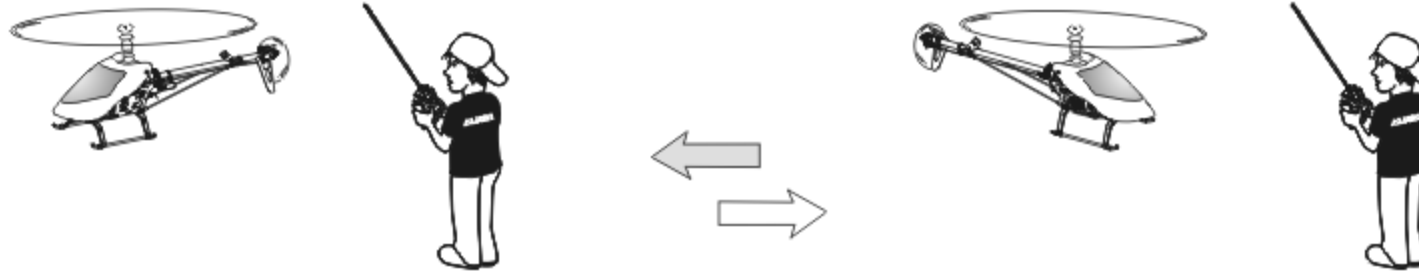

ADJUSTMENT OF EACH TRIM 飛行動作微調

Slowly raise the throttle stick and just as the helicopter lift-off the ground, you can use the trim to correct the action if the helicopter leans in a different direction.

慢慢升起油門搖桿，當直昇機剛剛離開地面時，若直昇機傾向不同方向，可使用微調修正動作。

1. Adjustment of rudder trim 調整方向舵微調

Just before the helicopter lift-off, the nose lean left/right...

When leans right, adjust the trim to left side.

When leans left, adjust the trim to right side.

在直昇機正要起飛時，機頭朝左/右方向偏移...

向右偏移時，微調向左調整。

向左偏移時，微調向右調整。

2. Adjustment of elevator trim 調整升降舵微調

Just before the helicopter lift-off, the nose lean forward/backward...

When leans forward, adjust the trim down.

When leans backward, adjust the trim up.

在直昇機正要起飛時，機頭朝前/後方向偏移...

向前偏移時，微調向下調整。

向後偏移時，微調向上調整。

3. Adjustment of Aileron trim 調整副翼微調

Just before the helicopter lift-off, the body lean left/right...

When leans right, adjust the trim to left side.

When leans left, adjust the trim to right side.

在直昇機正要起飛時，機身朝左/右方向偏移...

向右偏移時，微調向左調整。

向左偏移時，微調向右調整。

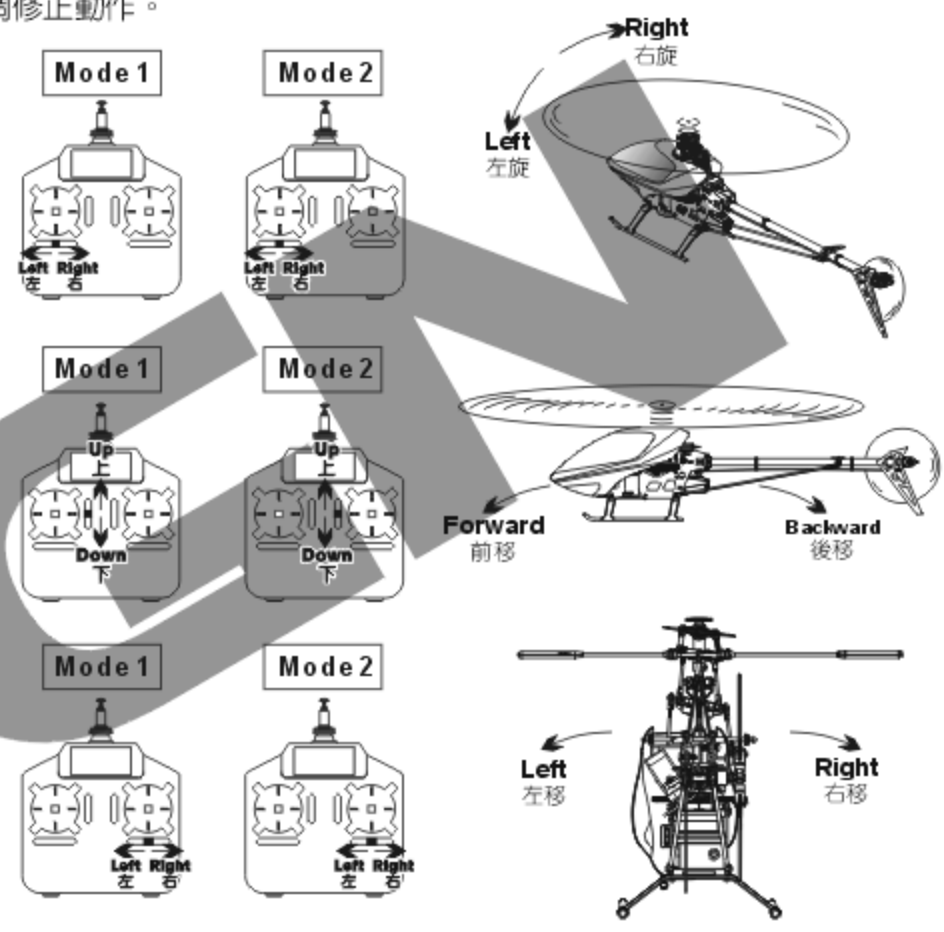

TROUBLE SHOOTING DURING FLIGHT 如何排除飛行中的狀況

	Situation 狀況	Cause 原因	Way to deal 對策
Blade Tracking 雙槳平衡	Out of tracking 雙槳	Adjustment of pitch rod has not been done. PITCH連桿長度調整不平均	Adjust the length of linkage rod(C) →Slight trim 調整連桿(C)長度
During Hovering 停旋	Low rotation of the rotor 主旋翼轉速偏低	★Pitch of main blade is high. ★主旋翼的PITCH偏高 ★Throttle curve is too low during hovering. ★停旋點油門曲線過低	★Lower the pitch about 5~6 during hovering (The rotation should be about 2,300~2,500rpm during hovering). ★調低Pitch停旋Pitch約5~6 (停旋時主旋翼需為約2,300-2,500rpm) ★Heighten the throttle curve during hovering. ★調高停旋點油門曲線
	High rotation of the rotor 主旋翼轉速偏高	★Pitch of main blade is low. ★主旋翼的PITCH偏低 ★Throttle curve is too high during hovering. ★停旋點油門曲線過高	★Adjust the pitch rod(C)(The rotation should be about 2,300~2,500rpm during hovering). ★調整連桿(C) (停旋時主旋翼需為約2,300-2,500RPM) ★Lower the throttle curve during hovering. ★調低停旋點油門曲線
Sensitivity of the gyro 陀螺儀感度	The tail leans to one side during hovering, or when trim the rudder and return to the neutral, the tail lags and cannot stay in a control position. 停旋時尾翼向某一邊偏移，或撥動方向舵並回復到中立點時，尾翼產生延遲，無法停頓在所控制位置上。	★Failure setting of tail neutral point. ★尾中立點設定不當 ★The sensitivity of the gyro is low. ★陀螺儀感度偏低	★Reset tail neutral point. ★重設尾中立點 ★Increase the sensitivity. ★增加感度
	The tail wags left and right during flight at hovering or full speed. 停懸或全油門時尾翼左右來回搖擺。	The sensitivity of the gyro is high. 陀螺儀感度偏高	Decrease the sensitivity. 降低感度

※If the problem is still there even after tried above, stop flying and contact with your seller.

※在做完以上調整後，仍然無法改善情況時，應立即停止飛行並連絡您的經銷商。

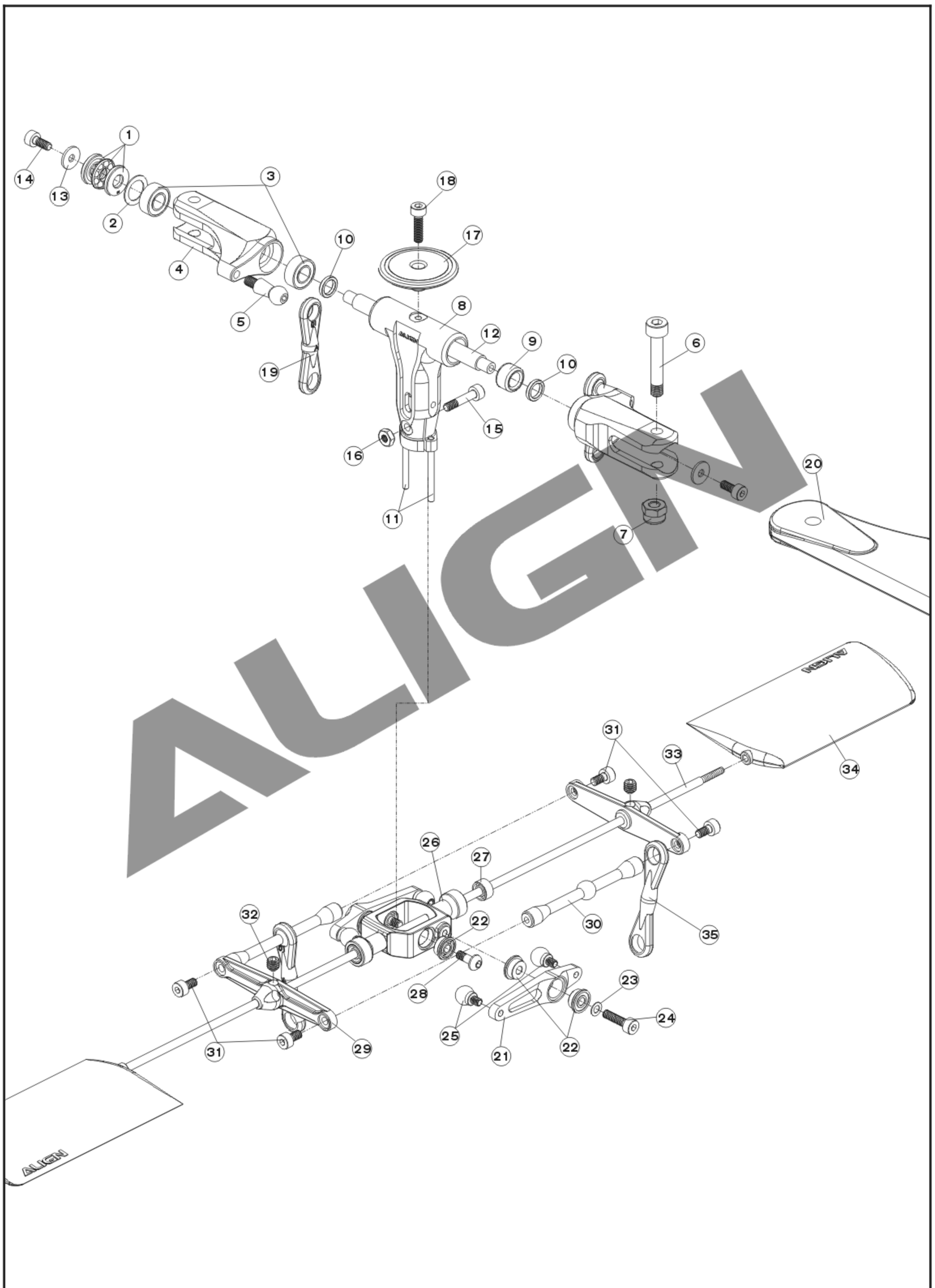

No.	Code No.	Name	Specification	Quantity	Remarks
1	HH2016	Thrust bearing 止推軸承	φ 3x φ 8x3.5mm	2	
2	W10055-1	Washer 華司	φ 5.5x φ 8x0.4mm	2	
3	HMR84ZZ	Bearing 軸承	φ 4x φ 8x3mm	4	
4	45H001	Metal main rotor holder 金屬主旋翼夾座	12x27x11.5mm	2	
5	45Z003	Linkage ball A (M2.5x4) 球頭A(M2.5x4)	φ 4.75x13mm	2	
6	T53016	Socket collar screw 圓頭內六角軸套螺絲	M3x16mm	2	
7	N10030	M3 Nut M3防鬆螺帽	M3	2	
8	45H007	Metal main rotor housing 金屬主旋翼固定座	17x37.5x11mm	1	
9	HH2021	Damper rubber 80° 橫軸墊圈-80°	φ 4x φ 6.5x4mm	2	
10	45H015	Spacer 橫軸鋁套	φ 4x φ 15.6x1mm	2	
11	HH2003-1	Pin 定位插梢	φ 1.5x18.7mm	2	
12	45H012	Feathering shaft 橫軸	φ 3x φ 4x51mm	1	
13	W10020	Washer 華司	φ 2x φ 6x0.6mm	2	
14	T62006	Socket screw 圓頭內六角螺絲	M2x6mm	2	
15	T62012-1	Socket collar screw 圓頭內六角軸套螺絲	M2x12mm	1	
16	N10020-1	M2 Nut M2螺帽	M2	1	
17	45H016	Metal head stopper 金屬旋翼頭制動器	φ 20x6.4mm	1	
18	T52005	Socket screw 圓頭內六角螺絲	M2x5mm	1	
19	45Z001	Ball link A 連桿頭A	19x2.3mm	2	
20	KU110024	325D Carbon fiber blade 325D碳纖主旋翼	325mm	2	
21	45H002	Metal SF Mixing arm 金屬SF控制搖臂	30.25x3.95mm	2	
22	HFMR52ZZ	Bearing 軸承	φ 2x φ 5x φ 6x2.3mm	6	
23	W10020-1	Washer 華司	φ 2x φ 3.6x0.2mm	2	
24	T52008	Socket screw 圓頭內六角螺絲	M2x8mm	2	
25	HH4006S-1	Linkage ball A (M2x2.5) 球頭A(M2x2.5)	φ 4.75x7.18mm	4	
26	45H014	Metal flybar seesaw holder 金屬平衡桿固定座	36.1x16.9x7mm	1	
27	HMR52ZZ	Bearing 軸承	φ 2 φ 5x2.5mm	2	
28	T52055	Socket button head collar screw 半圓頭內六角軸套螺絲	M2x5.5mm	2	
29	45H003	Metal flybar control arm 金屬平衡翼控制臂	36x9mm	2	
30	45H028	Flybar control rod 平衡翼球型控制球桿	φ 4.3x39mm	2	
31	T62004	Socket screw 圓頭內六角螺絲	M2x4mm	4	
32	T73003	M3 Set screw M3止洩螺絲	M3x3mm	2	
33	HH4024	Flybar rod 平衡翼桿	φ 1.97x220mm	1	
34	HH4022	Flybar paddle 平衡翼		2	
35	45Z002	Ball link B 連桿頭B	24x2.3mm	2	

Specifications, contents of parts and availability are subject to change, Align RC is not responsible for inadvertent errors in this publications.
 本說明書內的材質、規格或零件包裝之內容物僅供參考。本公司將不對此印刷物之異動負責，也無法主動通知消費者，任何更新或異動，請以亞拓網頁為主。

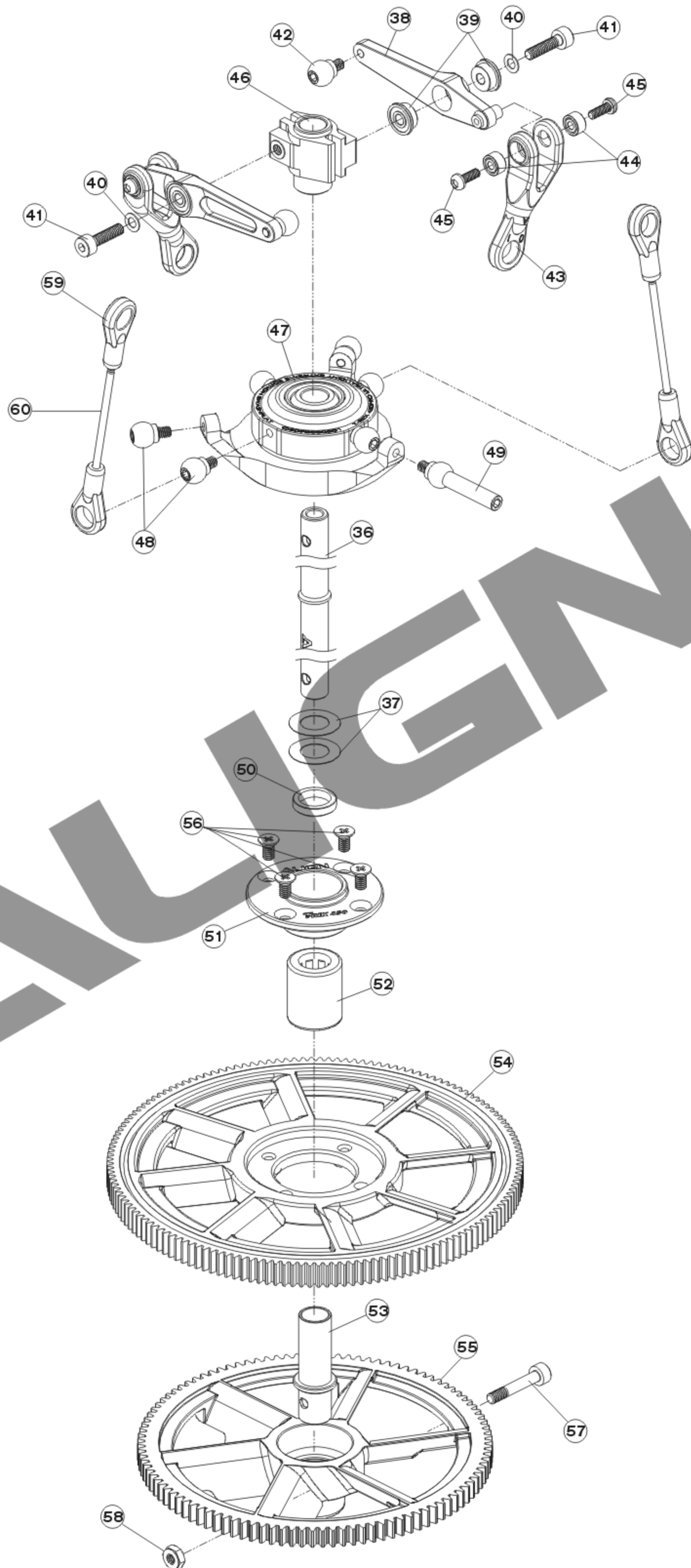

No.	Code No.	Name	Specification	Quantity	Remarks
36	45H013	Main shaft 主軸	φ 3x φ 5x118mm	1	
37	45H017	Main shaft spacer 主軸墊片	φ 5x φ 9x0.1mm	2	
38	45H004	Metal washout control arm 金屬穩定控制搖臂	35x7x5.5mm	2	
39	HFMR52ZZ-1	Bearing 軸承	φ 2x φ 5x φ 6x2.3mm	4	
40	W10020-1	Washer 華司	φ 2x φ 3.6x0.2mm	2	
41	T52008	Socket screw 圓頭內六角螺絲	M2x8mm	2	
42	HH4006S-1	Linkage ball A (M2x2.5) 球頭A(M2x2.5)	φ 4.75x7.18mm	2	
43	45H005	Radius arm Radius連桿	19.5x4.5x2.55mm	2	
44	H681ZZ	Bearing 軸承	φ 1.5x φ 4x2mm	4	
45	T50004-2	Socket button head screw 半圓頭內六角螺絲	0#x4mm	4	
46	HH5002L-3	Metal washout base 金屬向位器	13x13x9.8mm	1	
47		CCPM Metal Swashplate 金屬CCPM十字盤組		1	
48	HH4006S-1	Linkage ball A (M2x2.5) 球頭A(M2x2.5)	φ 4.75x7.18mm	6	
49	HH4011S-2	Long linkage ball (M2x2.5) 導板長球頭(M2x2.5)	φ 4.75x19.68mm	1	
50	HB6003-2	Shaft ring 單向軸套圈	φ 6x φ 8x1.6mm	1	
51	HB6008	Main gear case 主齒中心座	φ 10x φ 21.5x7.8mm	1	
52	HF0612-1	One-way bearing 單向軸承	φ 6x φ 10x12mm	1	
53	HB6002	One-way bearing shaft 單向軸承套	φ 5x φ 6x21.5mm	1	
54	HB6006	Main drive gear 主齒盤	150T	1	
55	HB6007	Autorotation tail drive gear 尾驅動主齒	106T	1	
56	S72004-1	Cross screw 皿頭十字螺絲	M2x4mm	4	
57	T62012-1	Socket collar screw 圓頭內六角軸套螺絲	M2x12mm	1	
58	N10020-1	M2 Nut M2螺帽	M2	1	
59	45Z004	Ball link 連桿頭		4	
60	HZ003-2	Linkage rod(C) 連桿C	φ 1.3x32mm	2	

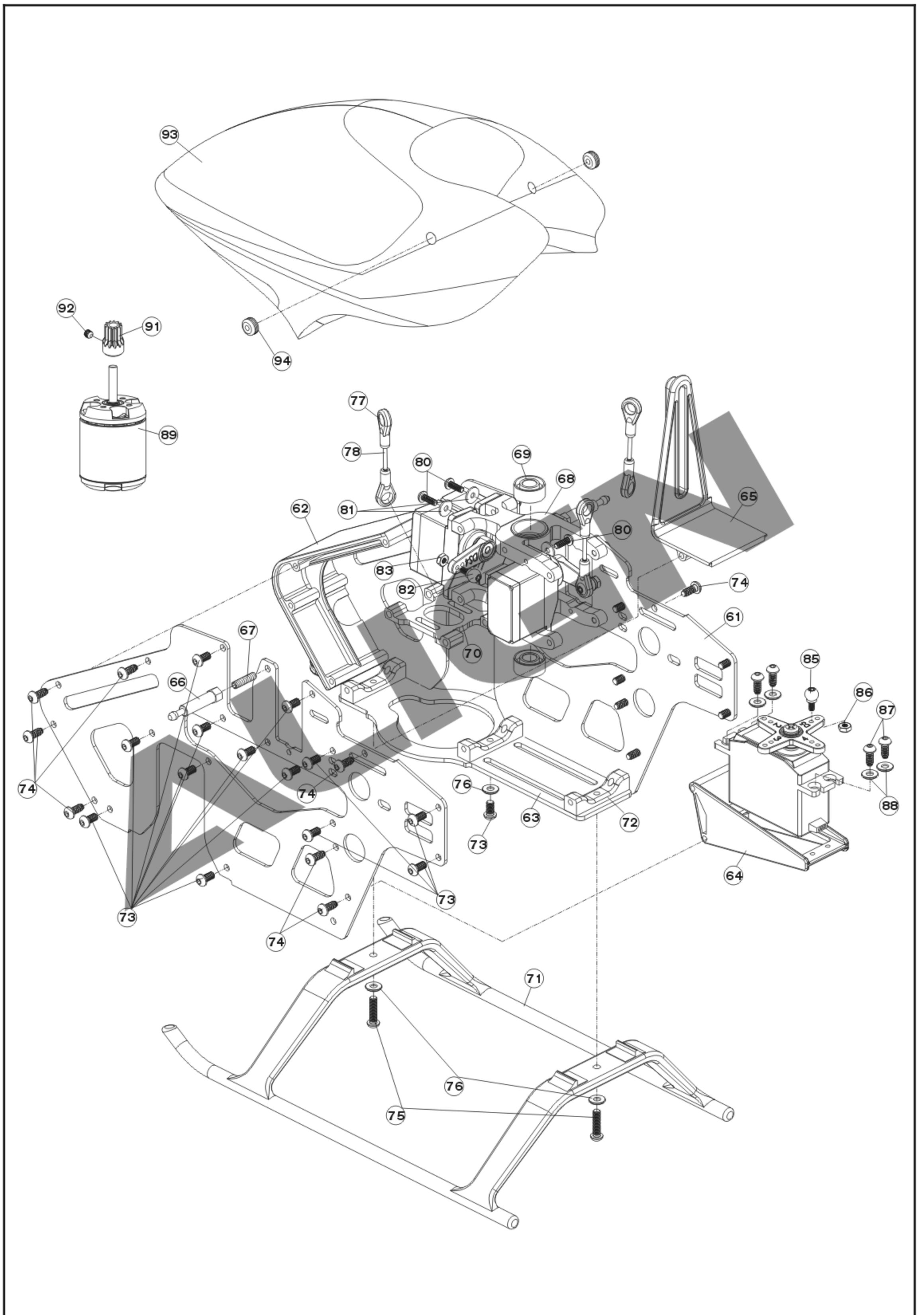

No.	Code No.	Name	Specification	Quantity	Remarks
61	45B002	Carbon fiber main frame 碳纖主體側板	199.33x96.75x1.2mm	2	
62	45B005	Battery mount 電池固定座	74.24x96.75x1.2mm	1	
63	45B003	Carbon fiber bottom plate 碳纖主體底板	120x26x1.6mm	1	
64	45T025	Tail servo mount 尾伺服器固定座		1	
65	45B004	Anti rotation bracket 十字盤導板	63x28.4x29.75mm	1	
66	45B008	Canopy mounting bolt 機頭罩鋁固定柱	φ 4x24mm	2	
67	T72512	M2.5 Set screw M2.5止洩螺絲	M2.5x12mm	2	
68	45B006	Metal bearing holder 金屬主軸固定座	50.5x26x7mm	2	
69	H685ZZ	Bearing 軸承	φ 5x φ 11x5mm	2	
70	45B007	Motor mount 馬達固定座	32x26x4mm	1	
71	45F001	Landing skid 腳架	106x110x39.5mm	1	
72	45F002	Skid mount 腳架固定座	26x6x7mm	3	
73	T52505-1	Socket button head screw 半圓頭內六角螺絲	M2.5x5mm	27	
74	S92606	Socket button head self tapping screw 半圓頭內六角自攻螺絲	T2.6x6mm	14	
75	T52510	Socket button head screw 半圓頭內六角螺絲	M2.5x10mm	2	
76	W10026	Washer 華司	φ 2.6x φ 5.8x0.6mm	3	
77	45Z004	Ball link 連桿頭		6	
78	HZ037-2	Linkage rod(D) 連桿D	φ 1.3x19mm	3	
80	T52006	Socket button head screw 半圓頭內六角螺絲	M2x6mm	6	
81	W10020	Washer 華司	φ 2x φ 6x0.6mm	6	
82	50H012-1	Linkage ball A (M2x3.5) 球頭A (M2x3.5)	φ 4.75x8.18mm	3	
83	N10020-1	M2 Nut M2螺帽	M2	3	
85	50H012-1	Linkage ball A (M2x3.5) 球頭A (M2x3.5)	φ 4.75x8.18mm	1	
86	N10020-1	M2 Nut M2螺帽	M2	1	
87	S92606	Socket button head self tapping screw 半圓頭內六角自攻螺絲	T2.6x6mm	4	
88	W10026	Washer 華司	φ 2.6x φ 5.8x0.6mm	4	
89		Motor 馬達	3500KV	1	
91	HG35145	Motor pinion gear 14T 14T馬達主齒	14T	1	
92	T73003	M3 Set screw M3止洩螺絲	M3x3mm	1	
93	45B009	Canopy 機頭罩		1	
94	HB8008-1	Canopy nut 機頭罩護墊	φ 2.3x φ 7x3.6mm	2	
95		Tail drive gear assembly 軸傳尾傳動輪組		1	
96	HMR83ZZ	Bearing 軸承	φ 3x φ 8x3mm	2	
97	45T005	Long umbrella gear 軸傳長傘齒	φ 2.6x φ 13.8x19.25mm	1	
98	50106ZZ	Bearing 軸承	φ 6x φ 10x3mm	2	
99	45T001	Tail boom mount (Left) 軸傳尾管固定座(左)	64.25x32.5x14.5mm	1	
100	45T002	Tail boom mount (Right) 軸傳尾管固定座(右)	64.25x32.5x14.5mm	1	
101	45T003	Hexo mounting bolt 六角鋁柱	4x25.9mm	4	
102	HT2004	Tail boom 尾管	φ 11x φ 12x347mm	1	
103	HT9004	Tail control guide 尾控制桿固定環	φ 12.2x φ 14.6x4mm	2	
104	45Z004	Ball link 連桿頭		2	
105	45T026	Rudder control rod 尾舵控制連桿	φ 1.3x330mm	1	
106		Torque tube 尾傳動軸桿		1	
107	45T024A	Torque tube bearing holder 尾傳動軸承座	φ 5.5x φ 11.25x8mm	1	
108	HMR84ZZ	Bearing 軸承	φ 4x φ 8x3mm	1	

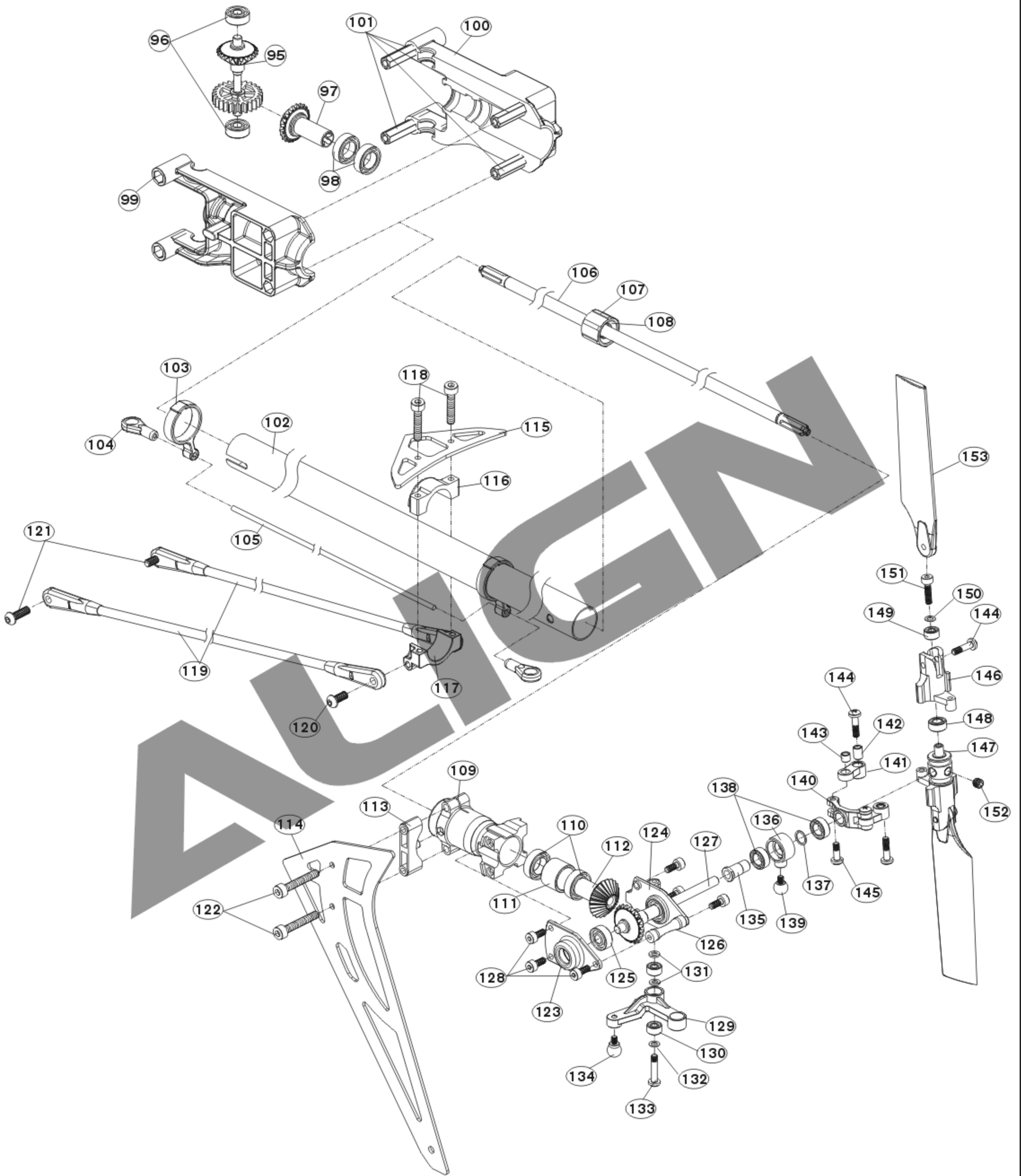

No.	Code No.	Name	Specification	Quantity	Remarks
109	45T009	Metal tail unit set 金屬軸傳尾齒箱		1	
110	50T106ZZ	Bearing 軸承	φ 6x φ 10x3mm	2	
111	45T010	Collar 軸傳齒箱襯套	φ 8x φ 10x7mm	1	
112	45T005	Long umbrella gear 軸傳長傘齒	φ 2.6x φ 13.8x19.25	1	
113	45T019	Vertical stabilizer mount 垂直翼固定座	16x4x7mm	1	
114	45T018	Carbon fiber vertical stabilizer 碳纖垂直翼	114.31x52.11x1.2mm	1	
115	45T019	Carbon fiber horizontal stabilizer 碳纖水平翼	51.86x22.36x1.2mm	1	
116	45T015	Metal stabilizer mount (Upper) 金屬水平翼固定上座	φ 11.8x19.8x6.25mm	1	
117	45T016	Metal stabilizer mount (Lower) 金屬水平翼固定下座	φ 11.8x19.8x7.5mm	1	
118	T52012	Socket screw 圓頭內六角螺絲	M2x12mm	2	
119	45T020	Tail boom brace end 尾管支撐架組	282x3.5mm	2	
120	T52506	Socket button head screw 半圓頭內六角螺絲	M2.5x6mm	2	
121	T52508	Socket button head screw 半圓頭內六角螺絲	M2.5x8mm	2	
122	T62018	Socket screw 圓頭內六角螺絲	M2x18mm	2	
123	45T007	Metal plate(L) 金屬尾軸傳左側板	26x15x6.05mm	1	
124	45T008	Metal plate(R) 金屬尾軸傳右側板	28.75x15x15mm	1	
125	HMR83ZZ	Bearing 軸承	φ 3x φ 8x3mm	2	
126	45T011	Aluminum bolt 尾軸傳齒箱鋁柱	φ 4x15.5mm	1	
127		Tail rotor shaft assembly 尾橫軸組		1	
128	T52005	Socket screw 圓頭內六角螺絲	M2x5mm	6	
129	HT4009	Tail rotor control arm 尾旋翼控制臂		1	
130	HMR52ZZ	Bearing 軸承	φ 2x φ 5x2.5mm	2	
131	W10020-2	Washer 華司	φ 2x φ 3.6x0.5mm	2	
132	W10020-1	Washer 華司	φ 2x φ 3.6x0.2mm	1	
133	T12009-1	Collar screw 軸套螺絲	M2x9mm	1	
134	50H012-1	Linkage ball A(M2x3.5) 球頭A (M2x3.5)	φ 4.75x8.18mm	1	
135	HT7002-1	Slide shaft 尾軸滑套	φ 3x φ 4.8x9.6mm	1	
136	HT7004A	Bearing holder 尾翼控制組軸承套座	φ 2.5x φ 6x2mm	1	
137	HT7004B	Collar 尾控制組軸承座鋁襯墊	φ 4x φ 5.1x0.3mm	1	
138	HMR74ZZ	Bearing 軸承	φ 4x φ 7x2.5mm	2	
139	HH4025-1	Linkage ball E(M2x2.5) 球頭E (M2x2.5)	φ 4.75x6.3mm	1	
140	HT7005	Metal T type arm 金屬尾T型控制臂	19.5x6x5mm	1	
141	HT7003B	Control link 尾控制連桿頭	φ 5.1x11.58x4.2mm	2	
142	50T106	Collar A 尾連桿頭銅套A	φ 2x φ 3x4mm	2	
143	HT7003C	Collar B 尾連桿頭銅套B	φ 2x φ 3x2.5mm	2	
144	T12008-4	Collar screw 軸套螺絲	M2x8mm	4	
145	T12006	Collar screw 軸套螺絲	M2x6mm	2	
146	45T013	Metal tail rotor holder 金屬尾旋翼夾座	φ 5x φ 6x14mm	2	
147	HT6001S-2	Tail rotor hub 尾旋翼T型座	φ 8x17.2mm	1	
148	HMR63ZZ	Bearing 軸承	φ 3x φ 6x2.5mm	2	
149	HMR52ZZ	Bearing 軸承	φ 2x φ 5x2.5mm	2	
150	W10020-1	Washer 華司	φ 2x φ 3.6x0.2mm	2	
151	T52008	Socket screw 圓頭內六角螺絲	M2x8mm	2	
152	T73003	M3 Set screw M3止洩螺絲	M3x3mm	1	
153	45T014	Tail blade 尾旋翼	61x15.75x2.6mm	2	

ALIGN

Specifications & Equipment/規格配備:

Length/機身長: 635mm

Height/機身高: 230mm

Main Blade Length/主旋翼長: 325mm

Main Rotor Diameter/主旋翼直徑: 710mm

Tail Rotor Diameter/尾旋翼直徑: 158mm

Motor Pinion Gear/馬達主齒: 14T

Main Drive Gear/傳動主齒輪: 150T

Autorotation Tail Drive Gear/尾驅動主齒: 106T

Tail Drive Gear/尾翼傳動齒: 25T

Drive Gear Ratio/齒輪傳動比: 1:10.7:4.24

Weight(w/o main blade)/空機重: 450g

Flying Weight/全配重: Approx. 780g

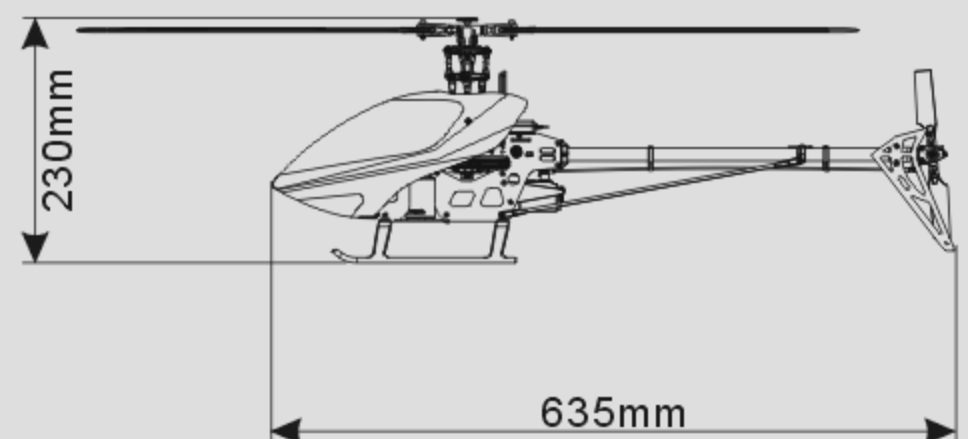
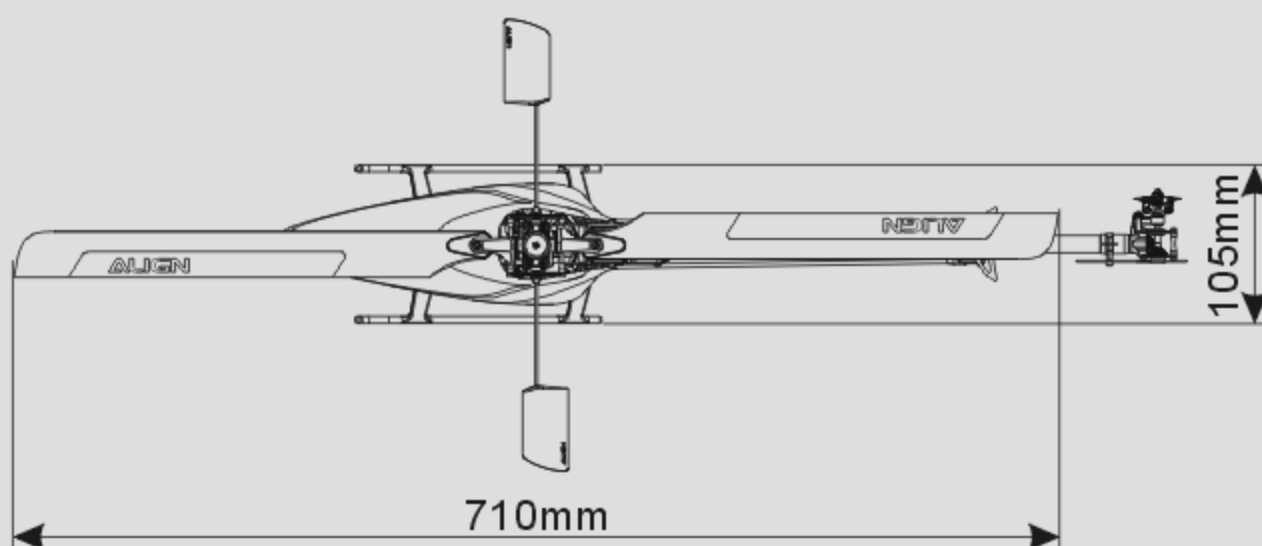

Features:

Newly designed head block with high rigidity and stability / Single piece integrated design of main bearing block and servo mount

Single piece integrated design of anti-rotation guide and gyro mount / Single piece integrated landing gear.

Highly stable flybar control system / High precision bearing mixing arms / Newly designed high resolution swashplate.

Single piece battery mount with integrated canopy mount designed to bring CG closer to disk plane.

Highly rigid frame with single piece carbon side and bottom plates / Highly efficient shaft driven tail design.

Weighted tail rotor blade grips to repel centripetal forces / Straight-up in-frame rudder servo mount for improved geometry.

Newly designed aerodynamic canopy / Newly designed high torque motor / Newly designed high strength main blade grips.