

FOR **TREX 500** **SCALE FUSELAGE 500E** **INSTRUCTION MANUAL** **使用說明書**

ALIGN



Model:HF5002



Model:HF5001

Thank you for buying ALIGN products. Please read this manual carefully before assembling. We recommend that you keep this manual for future reference regarding tuning and maintenance.

承蒙閣下選用亞拓遙控世界系列產品，謹表謝意。進入遙控世界之前必須告訴您許多相關的知識與注意事項，以確保您能夠在學習的過程中較得心應手。在開始操作之前，請務必詳閱本說明書，相信一定能夠給您帶來相當大的幫助，也請您妥善保管這本說明書，以作為日後參考。

Contents

1	INTRODUCTION 前言
1	ASSEMBLY ILLUSTRATION 組裝說明使用方式
2~6	ASSEMBLY STEPS 組裝步驟

Thank you for buying ALIGN Products. 500 scale fuselage is designed as an easy to use. Please read the manual carefully before assembling the model, and follow all precautions and recommendations located within the manual. Be sure to retain the manual for future reference, routine maintenance, and tuning. The scale fuselage is designed for ALIGN T-REX 500 Helicopter series use. You can easily put it on your T-REX 500 for new clothing.

感謝您選購亞拓產品，為了讓您容易方便的使用 500 像真機殼，請您詳細的閱讀完這本說明書之後再進行組裝以及操作這台直昇機，同時請您妥善的保存這本說明書、作為日後進行調整以及維修的參考。本像真機殼為針對亞拓 T-REX 500 系列直昇機之規格所設計，只要您擁有 T-REX 500，就可輕鬆為牠換件新衣，讓您成為眾所注目的焦點。

IMPORTANT NOTES 重要聲明

R/C helicopters are not toys. R/C helicopter utilize various high-tech products and technologies to provide superior performance. Improper use of this product can result in serious injury or even death. Please read this manual carefully before using and make sure to be conscious of your own personal safety and the safety of others and your environment when operating all ALIGN products.

Manufacturer and seller assume no liability for the operation or the use of this product.

Intended for use only by adults with experience flying remote control helicopters at a legal flying field. After the sale of this product we cannot maintain any control over its operation or usage.

After assembling the scale fuselage, the weight will increase and the structure will be more complex, so we recommend not flying 3D to avoid any accident and damage.

遙控直昇機並非玩具，它是結合了許多高科技產品所設計出來的休閒用品，所以商品的使用不當或不熟悉都可能會造成嚴重傷害甚至死亡，使用之前請務必詳讀本說明書，勿輕忽並注意自身安全。注意！任何遙控直昇機的使用，製造商和經銷商是無法對使用者於零件使用的損耗異常或組裝不當所發生之意外負任何責任，本產品是提供給有操作過模型直昇機經驗的成人或有相當技術的人員在旁指導於當地合法遙控飛行場飛行，以確保安全無虞下操作使用，產品售出後本公司將不負任何操作和使用控制上的任何性能與安全責任。安裝像真機殼後由於重量加重，且增加了結構的複雜性，故不建議進行3D飛行，以免發生不可預期的意外及損失。

R/C products require a certain degree of skill to operate, and is a consumer item. Any damage or dissatisfaction as a result of accidents or modifications are not covered by any warranty and cannot be returned for repair or replacement. Please contact our distributors for free technical consultation and parts at discounted rates when you experience problems during operation or maintenance.

模型商品屬於需高操作技術且為消耗性之商品，如經拆裝使用後，會造成不等情況零件損耗，任何使用情況所造成商品不良或不滿意，將無法於保固條件內更換新品或退貨，如遇有使用操作維修問題，本公司全省分公司或代理商將提供技術指導、特價零件供應服務。

2. PREPARATION BEFORE ASSEMBLY 組裝前準備事項

500 scale fuselage 500E, suitable for T-REX 500 Helicopter series.

500 像真機殼 500E，適用於 T-REX 500 遙控直昇機系列。

Before Assembling

1、Check for all the parts in the list come with the manual.

2、Some basic tools are needed to help the assembly.

組裝前準備事項

1、組裝之前請先確定內容物是否有缺失，仔細詳對後方可進行組裝。

2、組裝過程裡需要一些簡單的工具協助組裝。

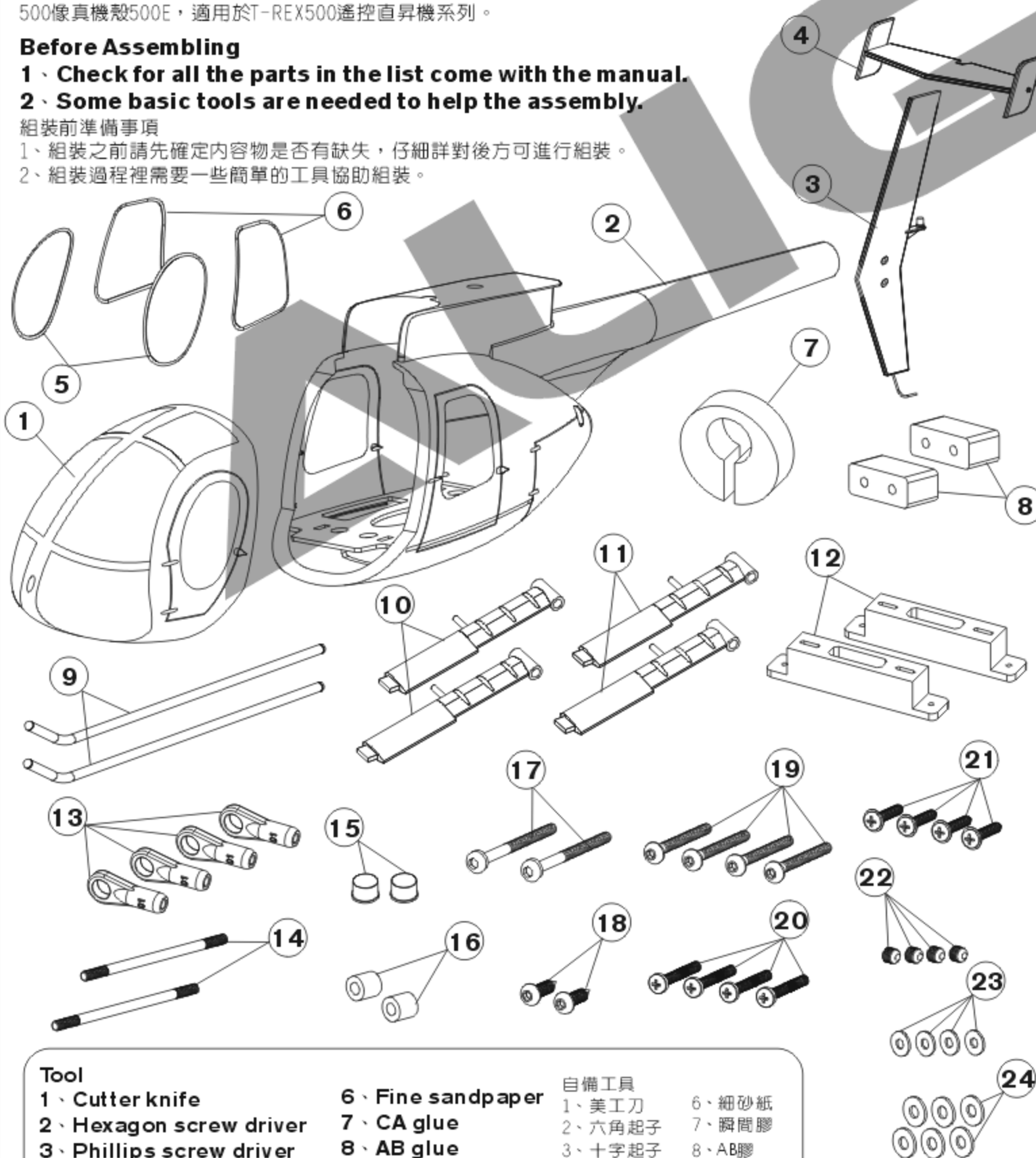

- 1. 500E Canopy x 1
- 2. 500E Fuselage x 1
- 3. Vertical stabilizer x 1
- 4. Horizontal Stabilizer x 1
- 5. 500E Front window x 2
- 6. 500E Rear window x 2
- 7. Pipe mount x 1
- 8. Servo block x 2
- 9. Skid pipe x 2
- 10. Front landing skid x 2
- 11. Rear landing skid x 2
- 12. Fuselage frame x 2
- 13. Ball link x 4
- 14. Linkage rod (D) (φ 1.96x39.5mm) x 2
- 15. Light Cover x 2
- 16. Vertical stabilizer bolt x 2
- 17. Socket collar screw (M2.5x30mm) x 2
- 18. Socket button head self tapping screw (T2.6x6mm) x 2
- 19. Socket button head screw (M2.5x20mm) x 4
- 20. Screw (M2x16mm) x 4
- 21. Washer side self tapping screw (T2x8mm) x 4
- 22. Set screw (M3x3mm) x 4
- 23. Washer (φ 2xφ 5x1mm) x 4
- 24. Washer (φ 2.5xφ 6x0.6mm) x 6

- 1. 500E 機艙罩 x 1
- 2. 500E 機殼 x 1
- 3. 垂直翼 x 1
- 4. 水平翼 x 1
- 5. 500E 前窗蓋 x 2
- 6. 500E 後窗蓋 x 2
- 7. 尾管固定泡棉 x 1
- 8. 伺服機固定鋁塊 x 2
- 9. 腳架鋁管 x 2
- 10. 前腳架 x 2
- 11. 後腳架 x 2
- 12. 機身架 x 2
- 13. 連桿頭 x 4
- 14. 連桿 (φ 1.96x39.5mm) x 2
- 15. 燈殼 x 2
- 16. 垂直翼固定鋁柱 x 2
- 17. 圓頭內六角軸套螺絲 (M2.5x30mm) x 2
- 18. 半圓頭內六角自攻螺絲 (T2.6x6mm) x 2
- 19. 半圓頭內六角螺絲 (M2.5x20mm) x 4
- 20. 圓頭十字螺絲 (M2x16mm) x 4
- 21. 華司面自攻螺絲 (T2x8mm) x 4
- 22. 止洩螺絲 (M3x3mm) x 4
- 23. 華司 (φ 2xφ 5x1mm) x 4
- 24. 華司 (φ 2.5xφ 6x0.6mm) x 6

Tool

- 1、Cutter knife
- 2、Hexagon screw driver
- 3、Phillips screw driver
- 4、File
- 5、Diagonal cutting pliers

- 6、Fine sandpaper
- 7、CA glue
- 8、AB glue
- 9、Scissors

自備工具

- 1、美工刀
- 2、六角起子
- 3、十字起子
- 4、銼刀
- 5、斜口鉗
- 6、細砂紙
- 7、瞬間膠
- 8、AB膠
- 9、剪刀

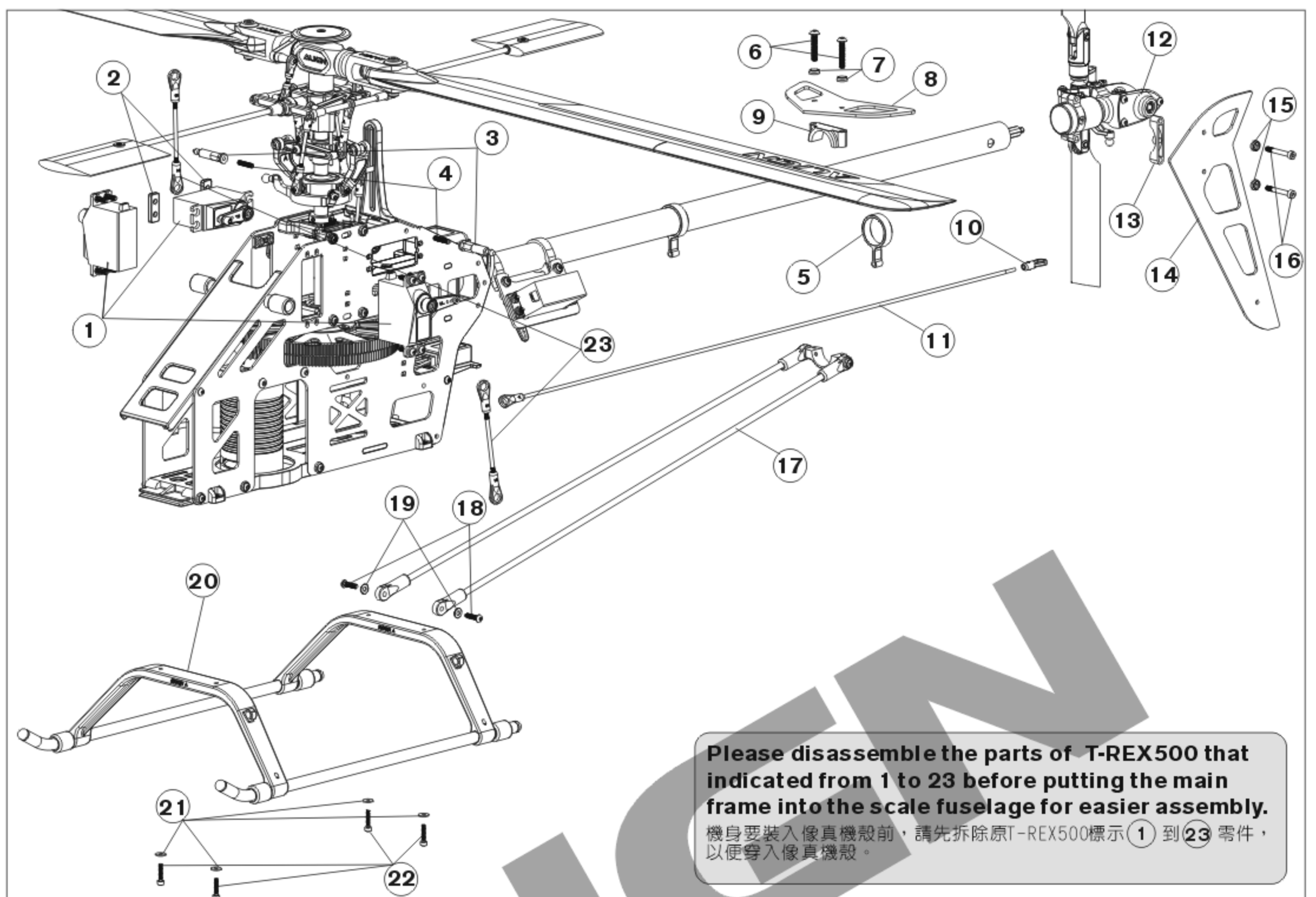

Please disassemble the parts of T-REX500 that indicated from 1 to 23 before putting the main frame into the scale fuselage for easier assembly.
機身要裝入像真機殼前，請先拆除原T-REX500標示(1)到(23)零件，以便穿入像真機殼。

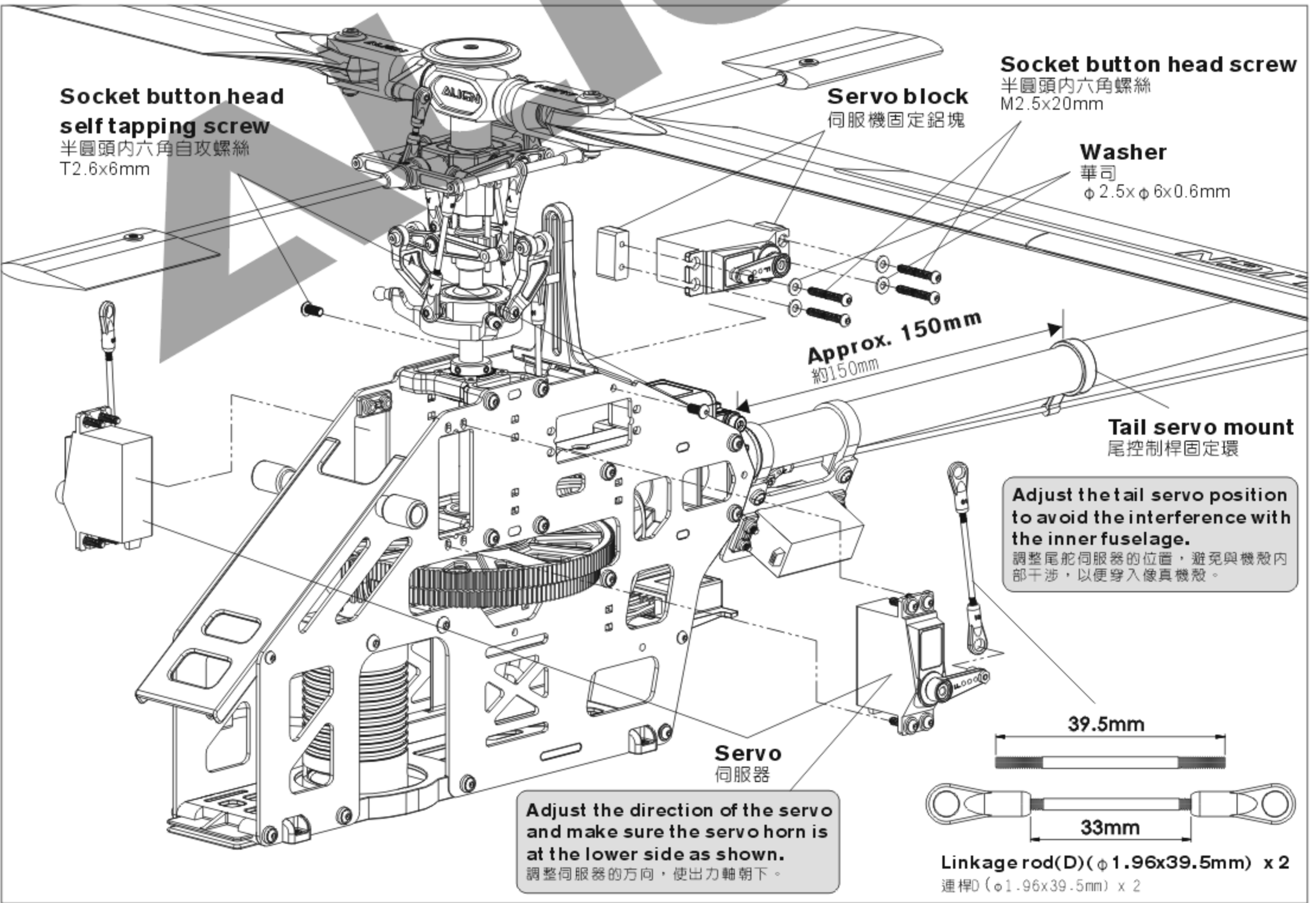

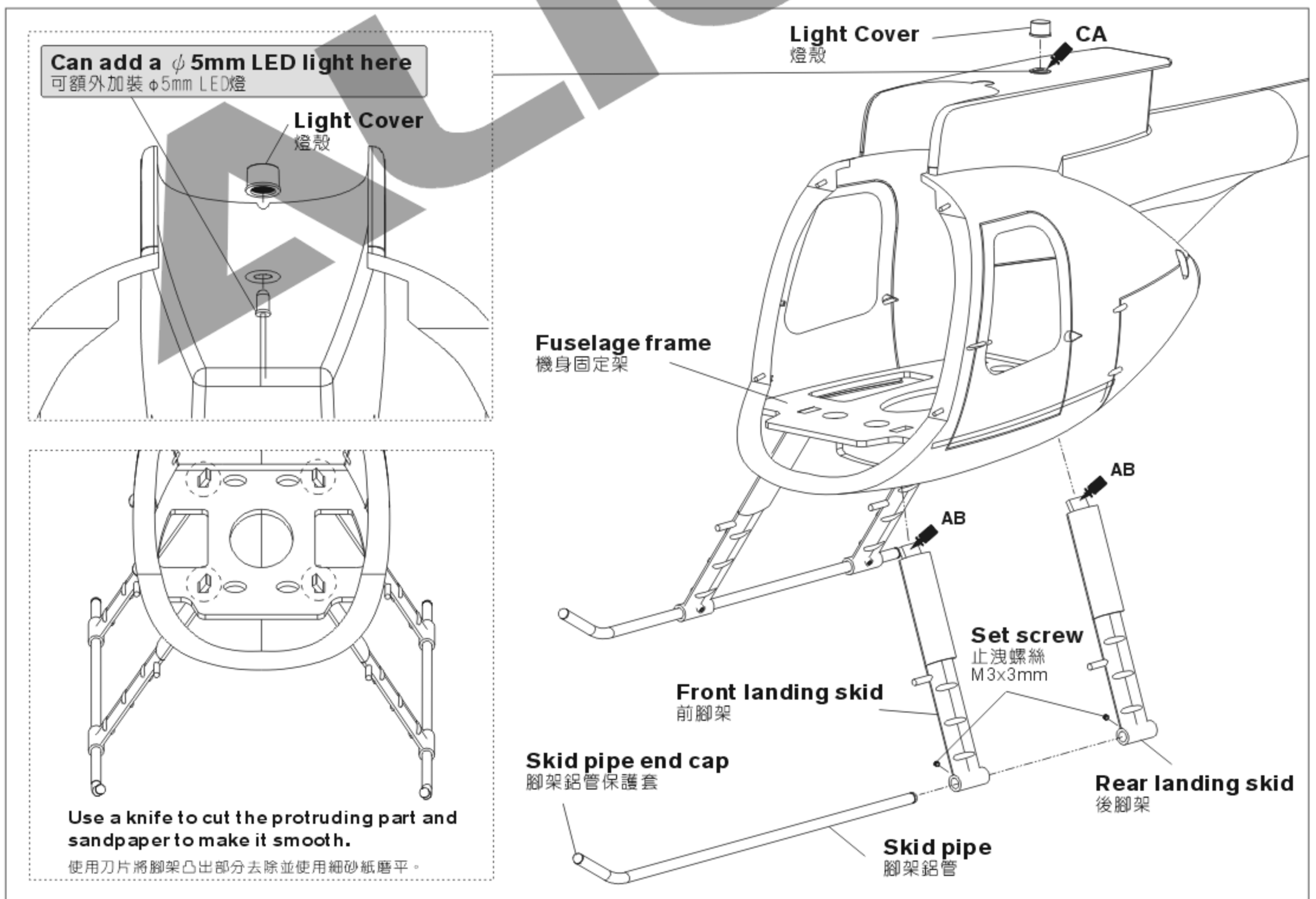
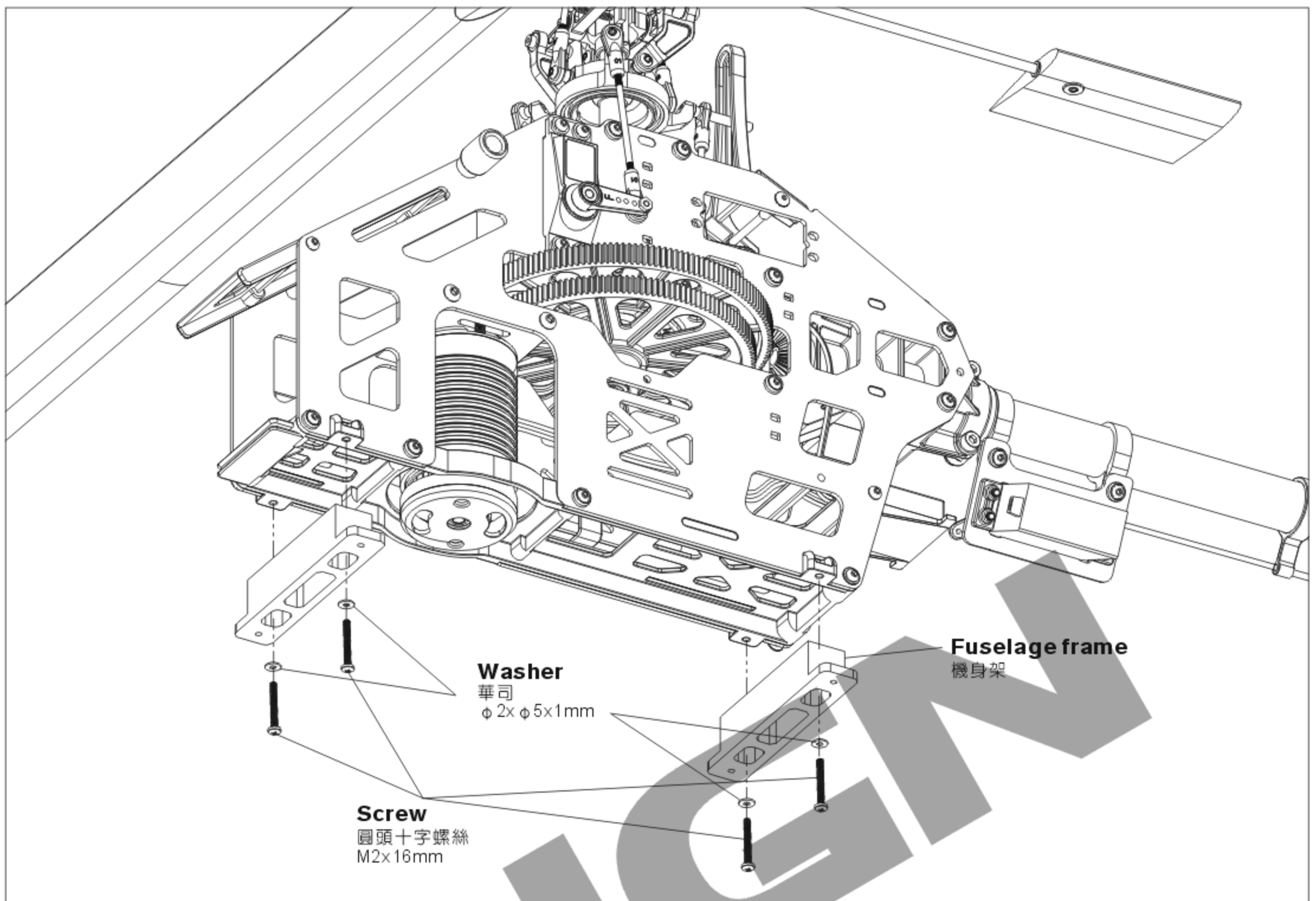

Insert the T-REX500 into the fuselage.

將T-REX500裝入像真機殼內。

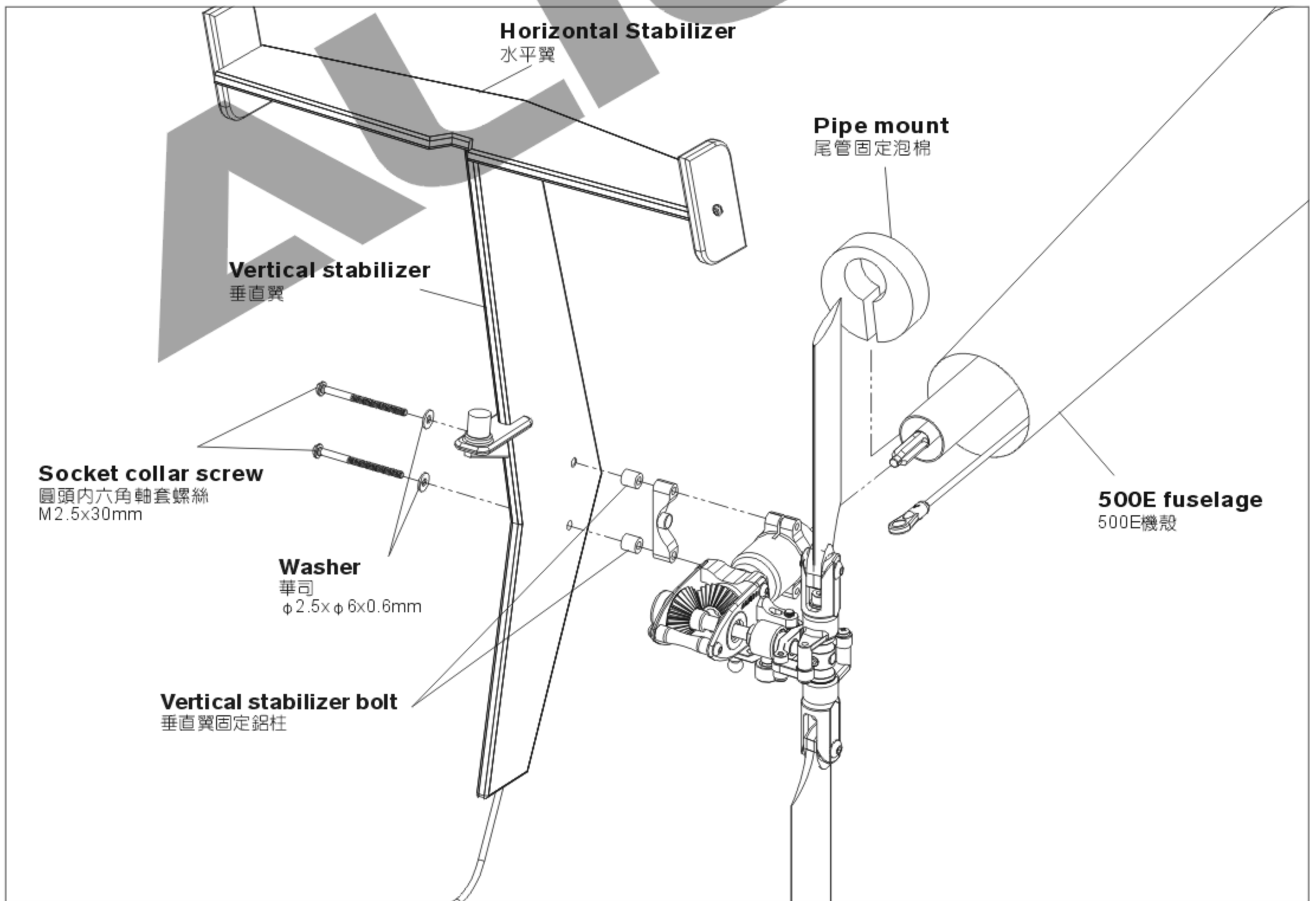
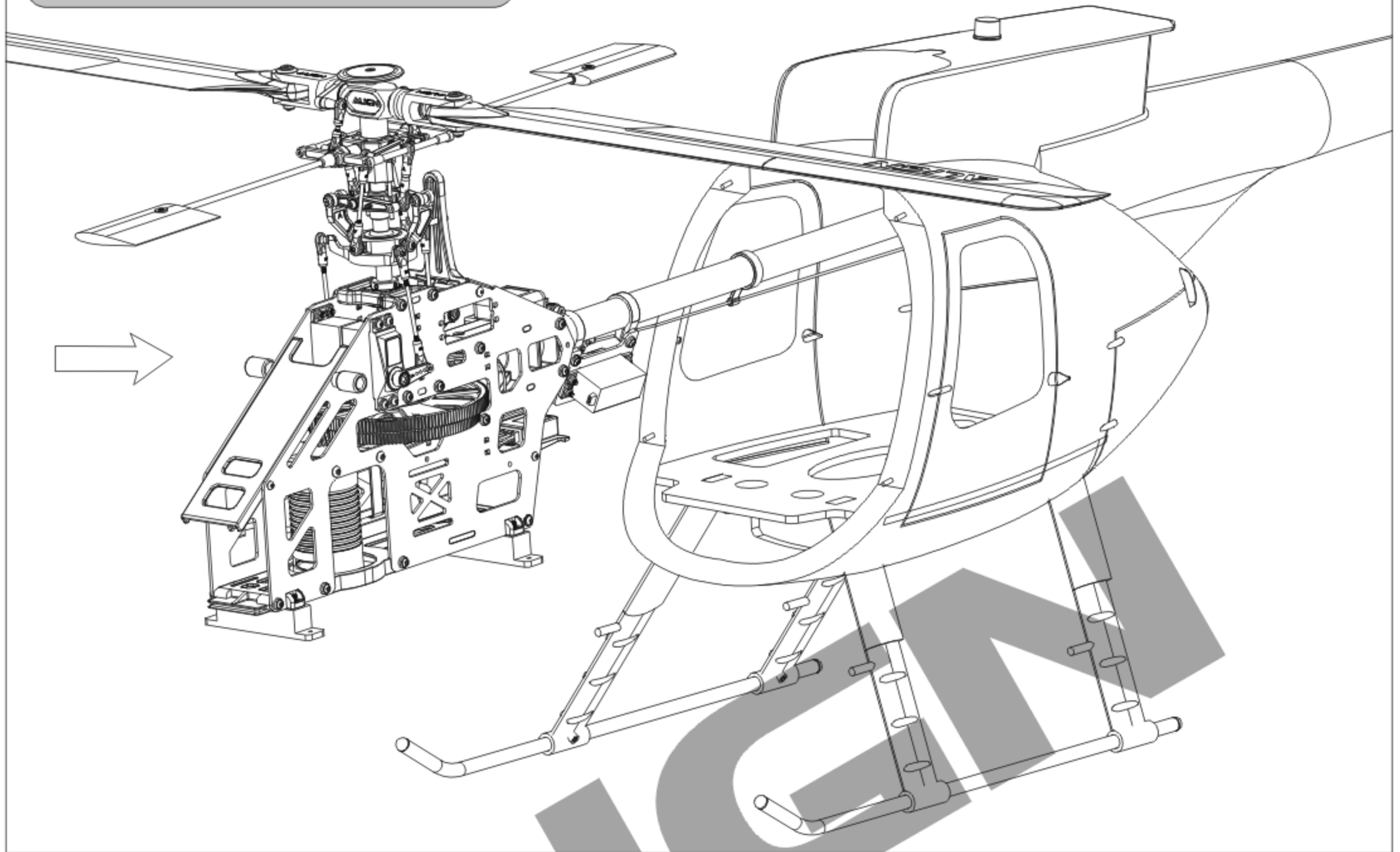

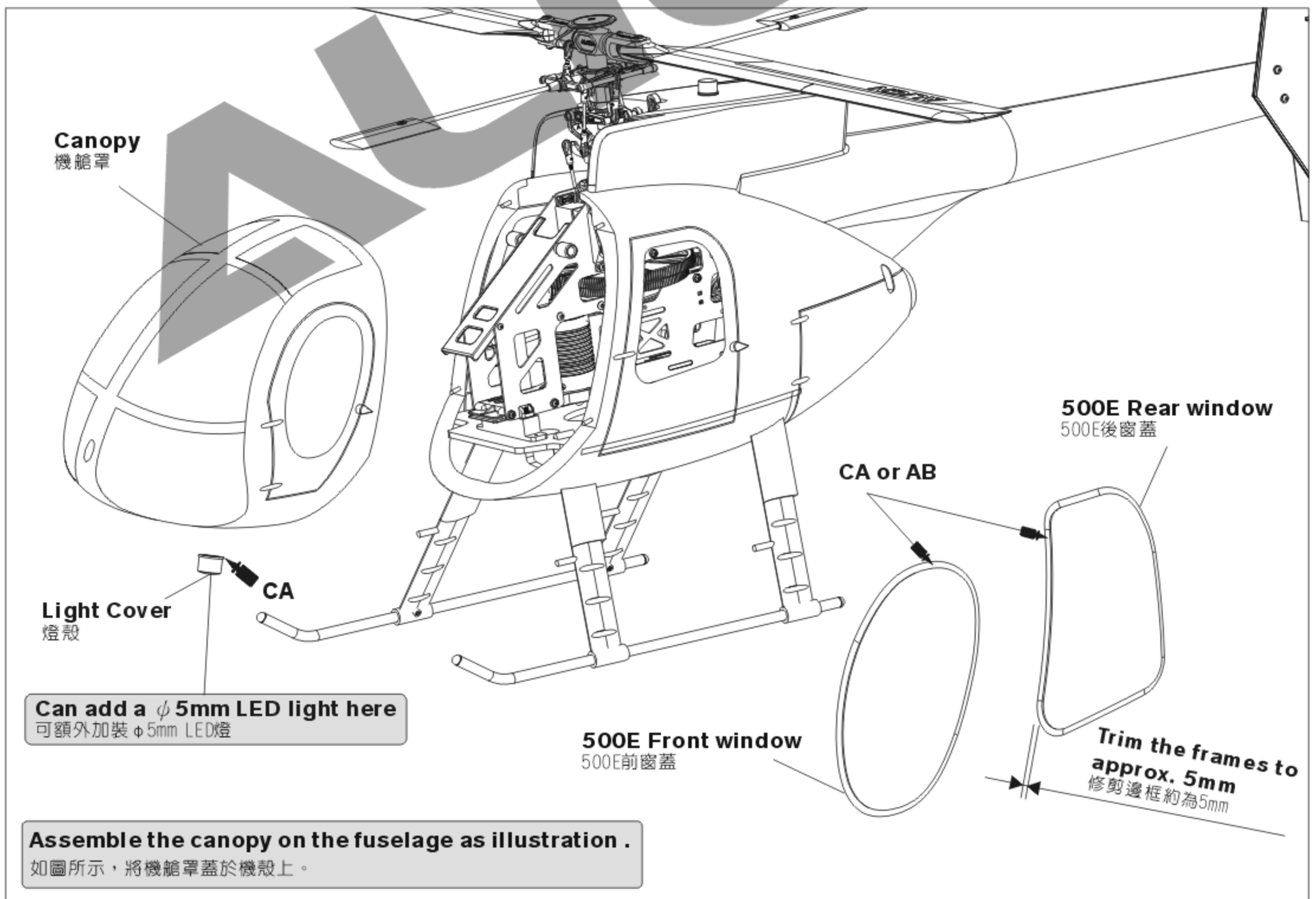
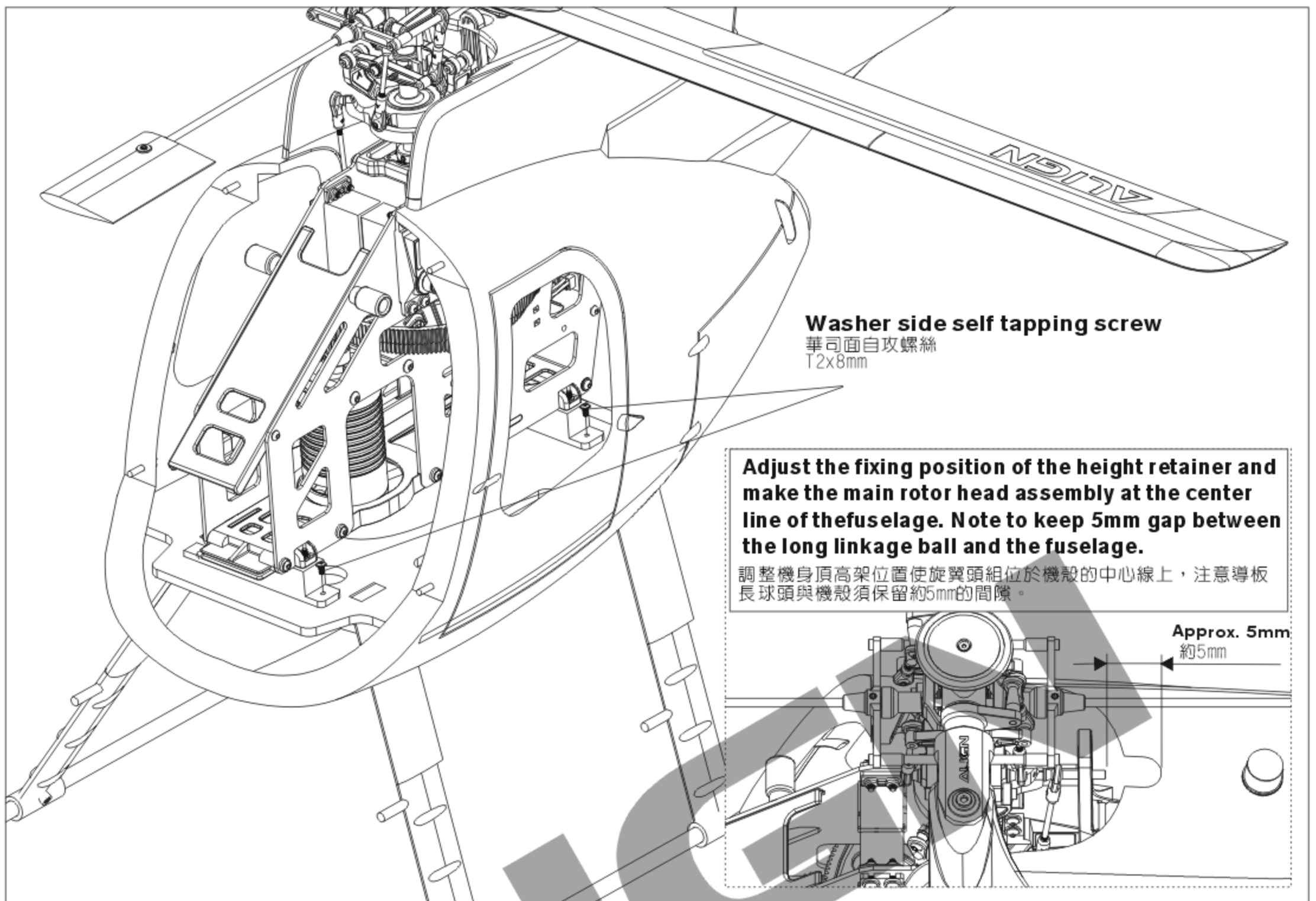

Complete illustration.

組立完成圖。

Before flying, please carefully check every part again to make sure all parts are firmly secured without any interference.

請再詳細檢查各部位是否確實鎖緊與固定，並確定無干涉情形後才可以飛行。

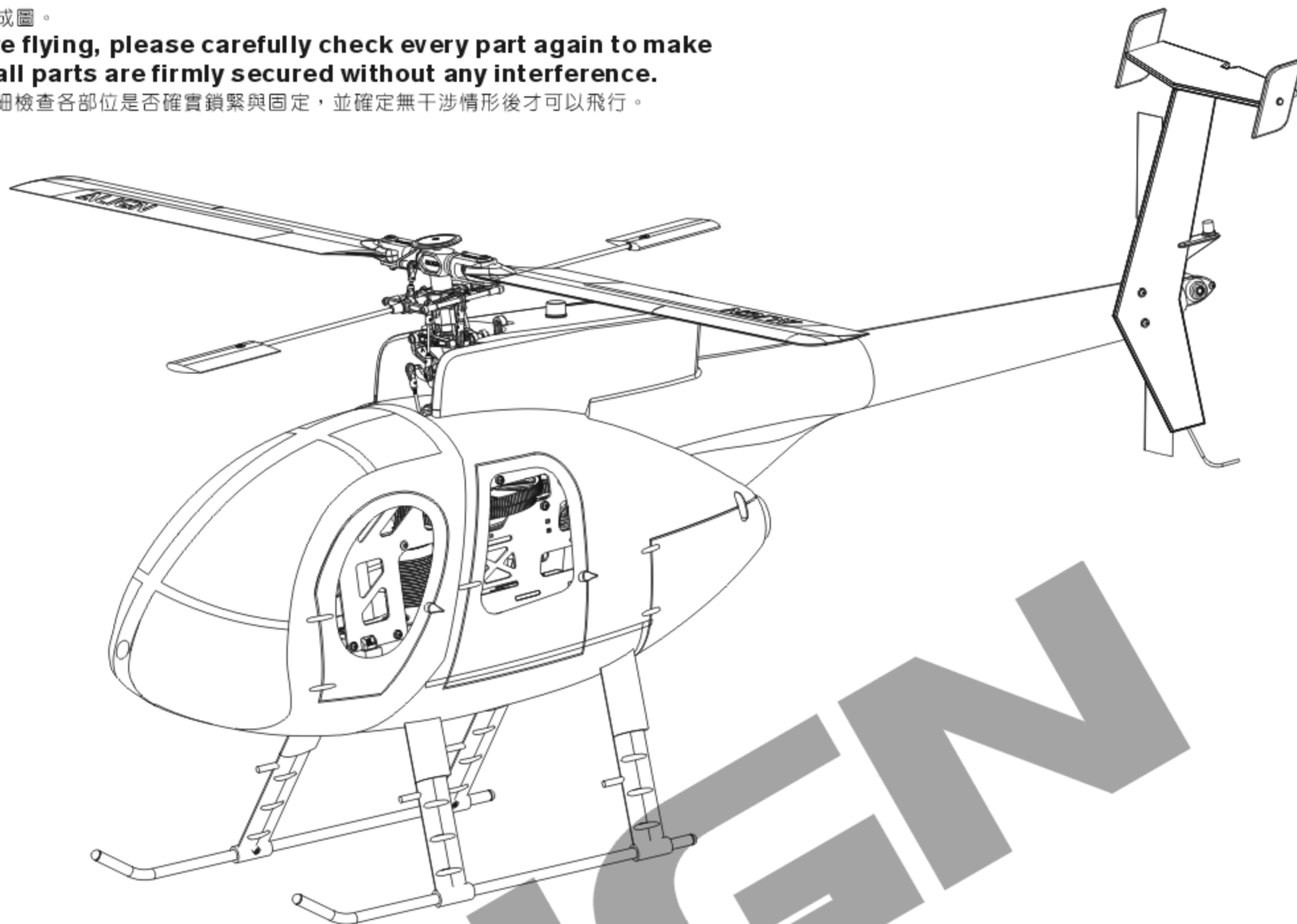

ALIGN

www.align.com.tw

www.alig

www.align.com.t

www.align.com.tw

www.align.c

www.align.com.tw



Specifications/規格配備:

Length/機身長: 890mm

Height/機身高: 420mm

Width/機身寬: 240mm

Weight/空機重: 700g

Suitable for ALIGN T-REX 500

適合ALIGN T-REX 500機型

